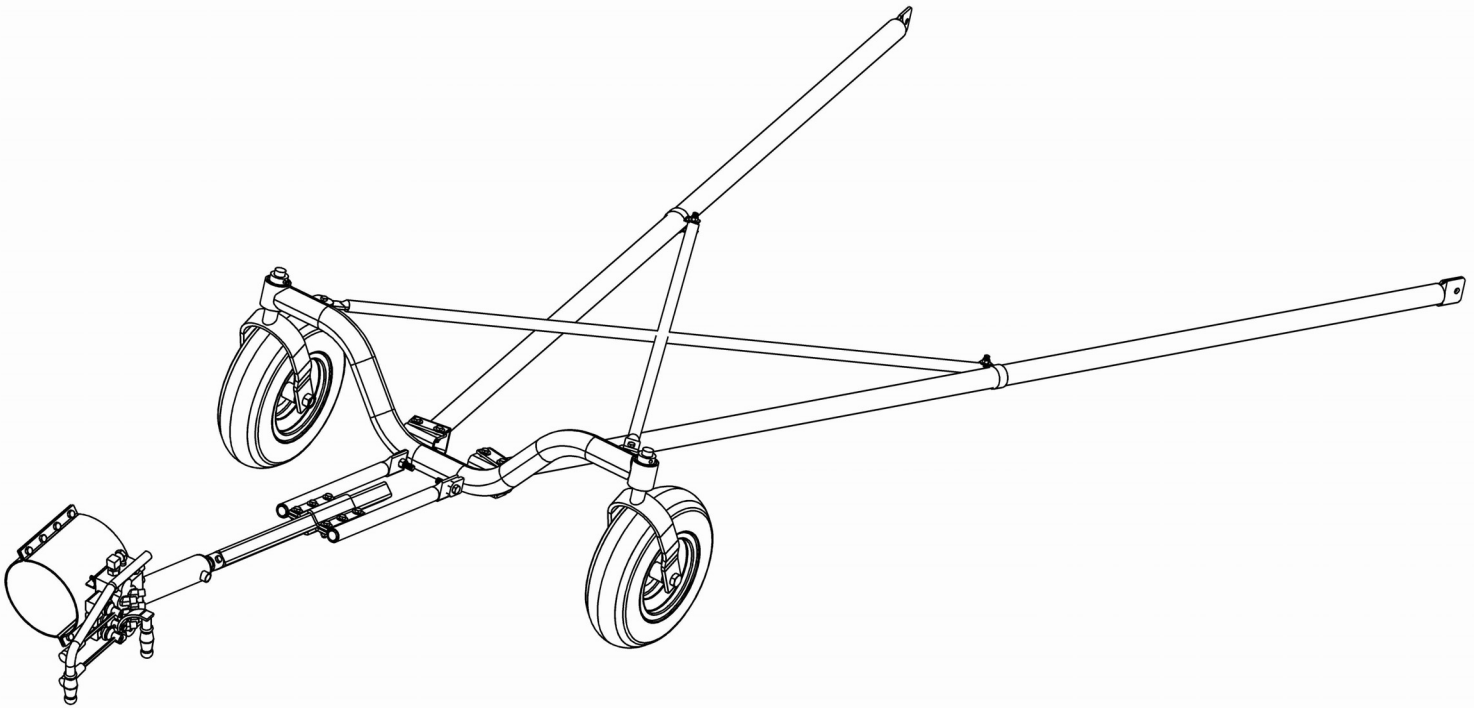




# GRAIN AUGER

## SELF-PROPELLED AUGER KIT ASSEMBLY & OPERATION



Read this manual before using product. Failure to follow instructions and safety precautions can result in serious injury, death, or property damage. Keep manual for future reference.

Part Number: 30532 R1

Revised: 27/1/12



This product has been designed and constructed according to general engineering standards<sup>a</sup>. Other local regulations may apply and must be followed by the operator. We strongly recommend that all personnel associated with this equipment be trained in the correct operational and safety procedures required for this product. Periodic reviews of this manual with all employees should be standard practice. For your convenience, we include this sign-off sheet so you can record your periodic reviews.

Date	Employee Signature	Employer Signature

a. Standards include organizations such as the American Society of Agricultural and Biological Engineers, American National Standards Institute, Canadian Standards Association, International Organization for Standardization, and/or others.

# TABLE OF CONTENTS

<b>1. Introduction .....</b>	<b>5</b>
<b>2. Safety First.....</b>	<b>7</b>
2.1. General Safety .....	8
2.2. Assembly Safety.....	9
2.3. Operation Safety .....	9
2.4. Transport and Placement Safety .....	11
2.5. Storage Safety.....	12
2.6. Maintenance Safety.....	12
2.7. Hydraulic Safety .....	12
2.8. Engine Safety .....	13
2.9. Tire Safety .....	13
2.10. Safety Decals .....	13
2.10.1. Decal Installation .....	13
2.10.2. Safety Decal Locations.....	14
<b>3. Assembly .....</b>	<b>15</b>
3.1. Gear Pump Assembly .....	15
3.2. Pump Guard Assembly .....	15
3.3. Oil Reservoir Assembly .....	16
3.4. Gear Drive Assembly .....	17
3.5. Over-Center Drive Assembly.....	17
3.6. Pinion Gear Adjustment .....	18
3.7. Transport Frame Installation .....	19
3.8. Control Ring, Hydraulic Cylinder, & Ram Extension Installation .....	21
3.9. Winch Assembly.....	23
3.9.1. Winch Alignment.....	24
3.10. Hose Kit Layout .....	24
3.11. Hose Kit Assembly .....	25
3.12. Cushion Valve Installation .....	26
<b>4. Transport &amp; Placement .....</b>	<b>27</b>
4.1. Transport Procedure .....	27
4.2. Placement Procedure.....	28
<b>5. Operation .....</b>	<b>29</b>
5.1. Start-Up .....	29
5.2. Operating Procedure .....	30

## TABLE OF CONTENTS

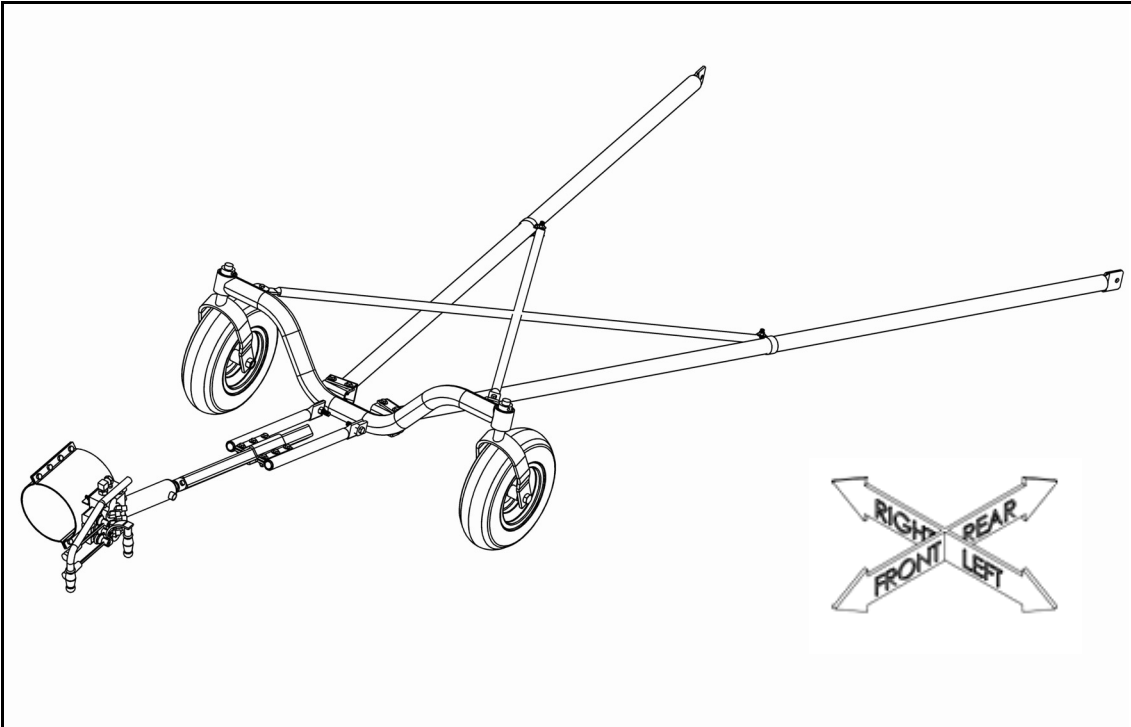
<b>6. Maintenance and Storage</b> .....	<b>33</b>
6.1. Maintenance Procedures.....	33
6.1.1. Hydraulic Winch Valve.....	33
6.1.2. Ram Speed Adjustment.....	34
6.1.3. Hydraulic Pressure Relief Valve Adjustment .....	34
6.1.4. Cushion Valve Adjustment.....	34
6.2. Storage Procedures.....	35
<b>7. Troubleshooting</b> .....	<b>37</b>
<b>8. Appendix</b> .....	<b>39</b>
8.1. Bolt Torque Values .....	39
8.2. Tightening O-Ring Fittings.....	40
8.3. Parts .....	42
8.3.1. Self-propelled Auger Kit.....	42
Warranty.....	45

# 1. Introduction

Congratulations. As the new owner of a Westfield self-propelled auger, you will be working with equipment especially designed to complement and improve your farming operation. Please read this manual to familiarize yourself with the various features of the machine, and the necessary precautions for efficient and safe operation. Anyone else who will be using this auger should also be familiar with all safety precautions. A sign-off form is supplied on the inside cover for your convenience and permanent records.

Keep this manual handy for frequent reference and to review with new personnel. Call your Westfield distributor or dealer if you need assistance, information, or additional copies of the manual.

**OPERATOR ORIENTATION**—The directions left, right, front, and rear, as mentioned throughout the manual, are as seen from the tractor or towing vehicle's driver's seat, and facing in the direction of travel when the unit is being transported.



The diagram shows a side view of a self-propelled auger. It features a front wheel, a rear wheel, a motor housing at the front, and a long auger shaft extending to the right. A directional sign is located in the lower right corner of the diagram area. The sign is an 'X' shape with four arrows pointing outwards, labeled 'RIGHT', 'REAR', 'FRONT', and 'LEFT'.

SERIAL NUMBER: \_\_\_\_\_  
DATE PURCHASED: \_\_\_\_\_  
DEALER NAME: \_\_\_\_\_



# 2. Safety First



The Safety Alert symbol to the left identifies important safety messages on the product and in the manual. When you see this symbol, be alert to the possibility of personal injury or death. Follow the instructions in the safety messages. Why is SAFETY important to you?

Three big reasons:

- Accidents disable and kill.
- Accidents cost.
- Accidents can be avoided.

## SIGNAL WORDS

Note the use of the signal words **DANGER**, **WARNING**, **CAUTION**, and **NOTICE** with the safety messages. The appropriate signal word for each message has been selected using the definitions below as a guideline.

The Safety Alert symbol means: "ATTENTION, BE ALERT! YOUR SAFETY IS INVOLVED".

<b>DANGER</b>	
	Indicates an imminently hazardous situation that, if not avoided, will result in serious injury or death.
<b>WARNING</b>	
	Indicates a hazardous situation that, if not avoided, could result in serious injury or death.
<b>CAUTION</b>	
	Indicates a hazardous situation that, if not avoided, may result in minor or moderate injury.
<b>NOTICE</b>	
Indicates a potentially hazardous situation that, if not avoided, may result in property damage.	

## 2.1. GENERAL SAFETY

**Important:** *This general safety section includes instructions that apply to all safety practices. Any instructions specific to a certain safety practice (e.g., assembly safety), can be found in the appropriate section. Always read the complete instructional sections and not just these safety summaries before doing anything with the equipment.*

**YOU** are responsible for the **SAFE** use and maintenance of your equipment. **YOU** must ensure that you and anyone else who is going to work around the equipment understands all procedures and related **SAFETY** information contained in this manual.

Remember, **YOU** are the key to safety. Good safety practices not only protect you, but also the people around you. Make these practices a working part of your safety program.

- It is the equipment owner and the operator's responsibility to read and understand **ALL** safety instructions, safety decals, and manuals and follow them before assembling, operating, or maintaining the equipment. All accidents can be avoided.
- Equipment owners must give instructions and review the information initially and annually with all personnel before allowing them to operate this product. Untrained users/operators expose themselves and bystanders to possible serious injury or death.
- Use this equipment for its intended purposes only.
- Do not modify the equipment in any way. Unauthorized modification may impair the function and/or safety, and could affect the life of the equipment. Any modification to the equipment voids the warranty.
- Do not allow children, spectators, or bystanders within the work area.
- Have a first-aid kit available for use should the need arise, and know how to use it.
- Provide a fire extinguisher for use in case of an accident. Store in a highly visible and accessible place.
- Wear appropriate protective gear. This list includes, but is not limited to:
  - a hard hat
  - gloves
  - protective shoes with slip-resistant soles
  - protective goggles
  - hearing protection
  - dust mask or respirator
- For Powered Equipment: before servicing, adjusting, or repairing powered equipment, unplug, place all controls in neutral or off position, stop the engine or motor, remove ignition key or lock out power source, and wait for all moving parts to stop.





- Follow good shop practices:
  - keep service area clean and dry
  - be sure electrical outlets and tools are properly grounded
  - use adequate light for the job at hand
  - Think SAFETY! Work SAFELY!



## 2.2. ASSEMBLY SAFETY

---

- Read the instructions and familiarize yourself with the subassemblies and hardware making up the equipment.
- The components are large, heavy, and can be hard to handle. Be sure to use the proper tools, stands, jacks, and hoists for the job.
- Have 2 people handle the heavy bulky components.
- Place safety stands or large blocks under the machine or components before going beneath the component for assembly.
- Stay away from overhead power lines and obstructions when lifting the machine during assembly. Electrocutation can occur without direct contact. Contact with obstructions can damage components or cause them to fail.
- Tighten all fasteners to their specified torque before using the machine.

## 2.3. OPERATION SAFETY

---

- Have another person nearby who can shut down the equipment in case of accident.
- Do not operate with any of the safety guards removed.
- Keep body, hair, and clothing away from moving parts. Stay away from intake during operation.

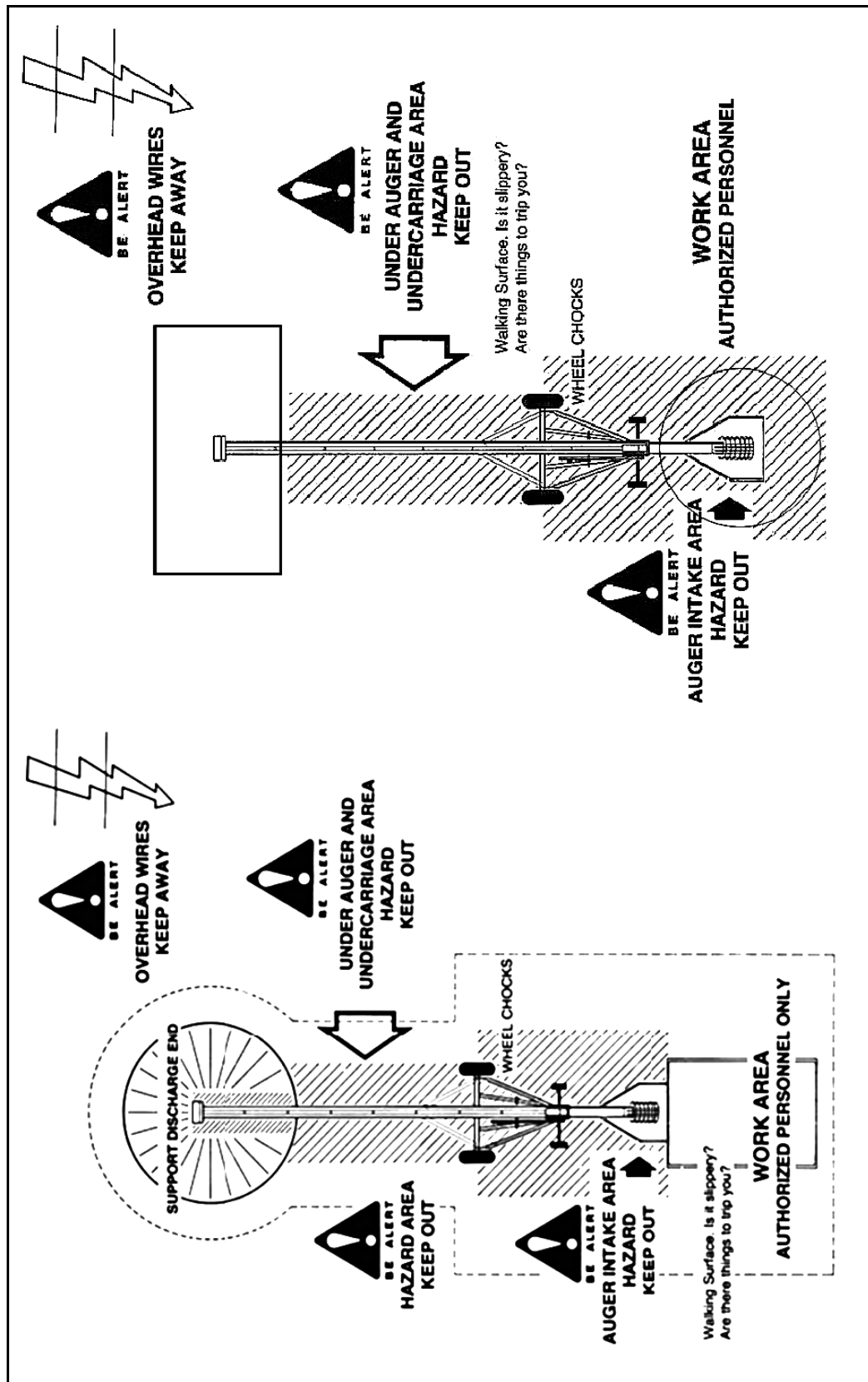


Figure 2.1 Auger Hazard Areas

## 2.4. TRANSPORT AND PLACEMENT SAFETY

- Before raising/lowering/moving the auger, make sure the area around the auger is clear of obstructions and/or unauthorized personnel. Never allow anyone to stand on or beneath auger while transporting or placing auger.
- Wheels must be free to move when raising or lowering auger.
- Do not stand between towing vehicle and grain auger when hitching.
- Make certain that the hitch pin is in place and the safety chain is properly attached. Use a type of hitch pin that will not permit auger to separate from towing vehicle.
- Use extreme care and minimum ground speed when operating or transporting on hillsides, over rough ground, or near ditches or fences.

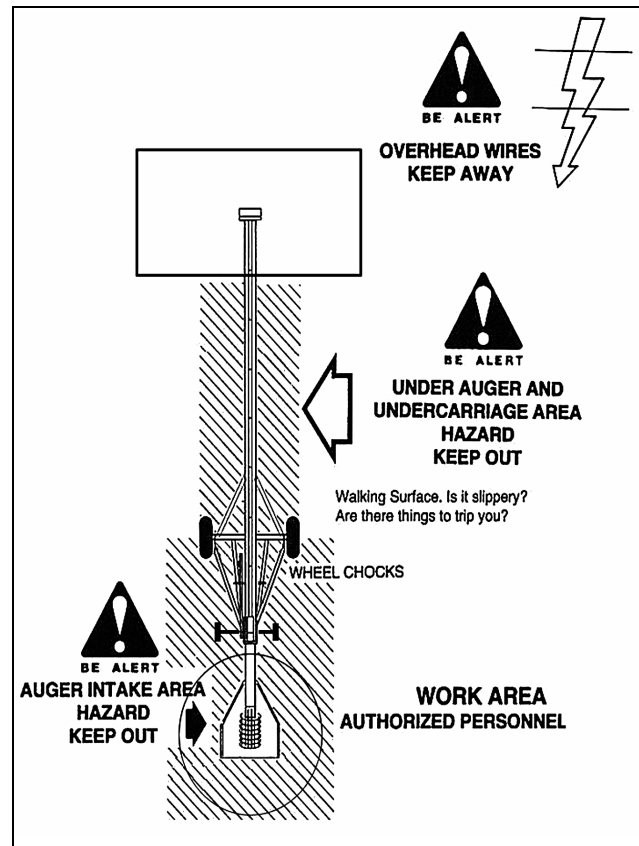


Figure 2.2 Work Safety Area

- Always attach an SMV (slow moving vehicle) sign before transporting auger, and equip the auger with the necessary lights for transportation where required by law. Always use hazard warning flashers on the tractor/towing vehicle when transporting unless prohibited by law.
- Do not allow riders on the machine, towing vehicle, tractor, or skid steer during transport.
- Stay away from overhead obstructions and power lines when operating and transporting. Electrocutation can occur without direct contact.
- Inflate tires to the manufacturer's recommended pressure.
- Review the work safety area diagram before starting work.
- Check with local authorities regarding transport on public roads. Obey all applicable laws and regulations.
- Always travel at a safe speed, never exceeding 15 mph (24 km/hr). Reduce speed on rough surfaces and use caution when turning corners or meeting traffic.
- Transport auger in full down position with slight tension on cable.
- Disengage wheel drive motors before towing.

## 2.5. STORAGE SAFETY

---

- Store in an area away from human activity.
- Do not permit children to play on or around the stored machine.

## 2.6. MAINTENANCE SAFETY

---

- Place all controls in neutral or off position, stop engine or motor, remove ignition key or lock out power source, and wait for all moving parts to stop before servicing, adjusting, or repairing.
- Before applying pressure to a hydraulic system, make sure all components are tight and that hoses and couplings are in good condition.
- Relieve pressure from hydraulic circuit before servicing or disconnecting from tractor.
- Place stands or blocks under the frame before working beneath the machine.
- After maintenance is complete, replace and secure all safety guards and safety devices, and if applicable, service doors and cleanout covers.
- Remove all tools and unused parts from machine before operation.
- Remove buildup of grease, oil, and debris.
- Inspect all parts. Ensure parts are in good condition and installed properly.

*Use only genuine Westfield replacement parts or equivalent. Replacement parts must meet ASAE standards or serious injury may result. Use of unauthorized parts will void the warranty. If in doubt, contact Westfield or your Westfield dealer.*


*Do not modify the equipment. Unauthorized modification may impart the function or safety of the equipment, could affect the life of the equipment, and will void your warranty.*

## 2.7. HYDRAULIC SAFETY

---

- Always place all hydraulic controls in neutral and relieve system pressure before disconnecting or working on hydraulic system.
- Keep all components in the hydraulic system tightly secured, clean and in good condition.
- Replace any worn, cut, abraded, flattened, or crimped hoses.
- Do not attempt any makeshift repairs to the hydraulic fittings or hoses with tape, clamps, or adhesive. The hydraulic system operates under extremely high pressure; such repairs will fail suddenly and create a hazardous and unsafe condition.

- Before moving a hydraulic cylinder, ensure that the attached component is safely secured.

<b>WARNING</b>	
	<p>Hydraulic fluid can cause serious injury if it penetrates the skin. If it does, see a doctor immediately.</p> <ul style="list-style-type: none"><li>• Relieve pressure before disconnecting hydraulic line.</li><li>• Wear proper hand and eye protection and use wood or cardboard, not hands, when searching for leaks.</li></ul>

## 2.8. ENGINE SAFETY

---

- Be sure to stop engine and remove key or lock out power before inspecting or servicing engine
- Refer to engine operation manual for further details.

## 2.9. TIRE SAFETY

---

- Failure to follow proper procedures when mounting a tire on a wheel or rim can produce an explosion that may result in serious injury or death.
- Do not attempt to mount a tire unless you have the proper equipment and experience to do the job.
- Have a qualified tire dealer or repair service perform required tire maintenance.
- When replacing worn tires, make sure they meet the original tire specifications. Never undersize the replacement tire.
- Do not weld to the tire rim with the tire mounted on the rim. This action may cause an explosion which could result in serious injury or death.
- Inflate tires to the manufacturers's recommended pressure.

## 2.10. SAFETY DECALS

---

- Keep safety decals clean and legible at all times.
- Replace safety decals that are missing or have become illegible. See decal location figures that follow.
- Replaced parts must display the same decal(s) as the original part.
- Safety decals are available from your distributor, dealer, or factory.

### 2.10.1. DECAL INSTALLATION

---

1. Decal area must be clean and dry, with a temperature above 50°F (10°C).

2. Decide on the exact position before you remove the backing paper.
3. Align the decal over the specified area and carefully press the small portion with the exposed sticky backing in place.
4. Slowly peel back the remaining paper and carefully smooth the remaining portion of the decal in place.
5. Small air pockets can be pierced with a pin and smoothed out using the sign backing paper.

## 2.10.2. SAFETY DECAL LOCATIONS

Replicas of the safety decals that are attached to the equipment are shown in the figure(s) that follow. Proper safety procedures require that you familiarize yourself with the various safety decals and the areas or particular functions that the decals apply to as well as the safety precautions that must be taken to avoid serious injury, death, or damage.

*\* Westfield reserves the right to update safety decals without notice. Safety decals may not be exactly as shown.*

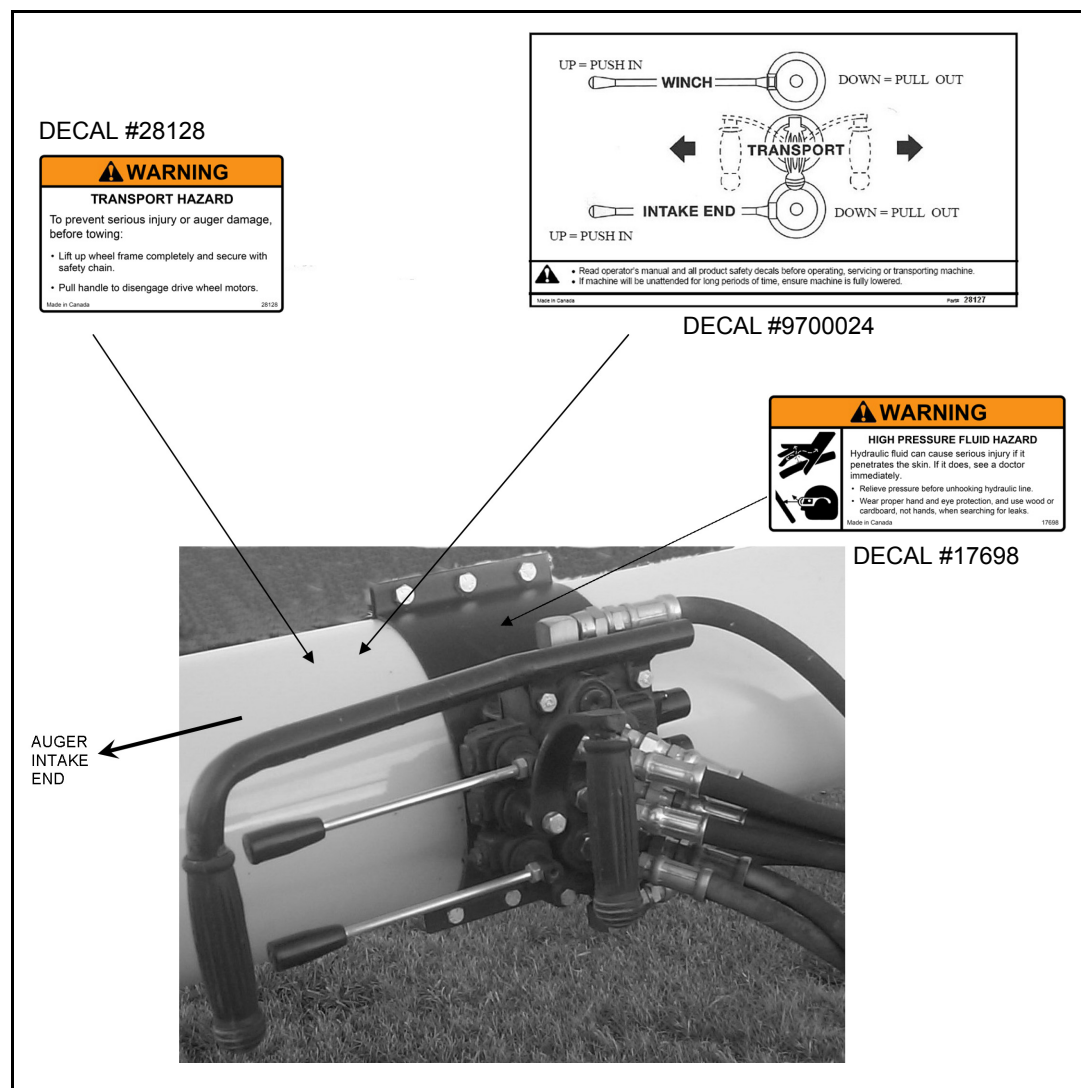



Figure 2.3 Safety Decal Locations

# 3. Assembly

**Warning:** Before continuing, ensure you have read and understand the relevant information in the safety section. Safety information is provided to help prevent serious injury, death, or property damage.

CAUTION	
	Ensure auger is in the fully lowered position and on a level surface with the wheels chocked before proceeding with any assembly.

## 3.1. GEAR PUMP ASSEMBLY

---

Refer to Figure 3.1 for assembly.

**Note:** *The engine pulley guard is removed from Figure 3.1 for illustrative purposes only.*

1. The over-center (o/c) pump bracket comes pre-assembled and is attached to the engine block with two 3/8" bolts. Use 1" pump shims to provide a flat mounting surface for the o/c pump bracket (Figure 3.1).
2. Install the single groove engine pulley and 1/2" x 4-1/2" pump pulley so they are in line.
3. Install the belt and slide the over-center bracket back to increase tension on the belt.
4. Tighten the 2 bolts holding the over-center bracket to the engine, then push down on the over-center handle to lock the belt in place. Allow approximately 3/4" to 1" deflection at the center of the belt.

**Important:** *The gear pump placement may be changed, but the pump MUST run counter-clockwise (when facing pump) at a maximum of 3600 rpm.*

## 3.2. PUMP GUARD ASSEMBLY

---

1. Bolt the pump guard bracket to the over-center pump bracket using one 3/8" x 1-1/2" bolt, washers, and locknut (Figure 3.1).
  - The pump guard bracket should be installed at the pump end of the long, adjustable slot through the middle of the over-center bracket.
  - Place 2 washers between the pump guard bracket and the over-center bracket so that the angle of the bracket may be adjusted to the belt.
2. Attach the pump guard to the pump guard bracket.
  - Align the pump guard with the belt that runs between the pump and the engine. The pump guard bracket may need to be adjusted to align the guard.
  - Ensure that there is adequate clearance between the belt and the pump guard with belt engaged and disengaged.

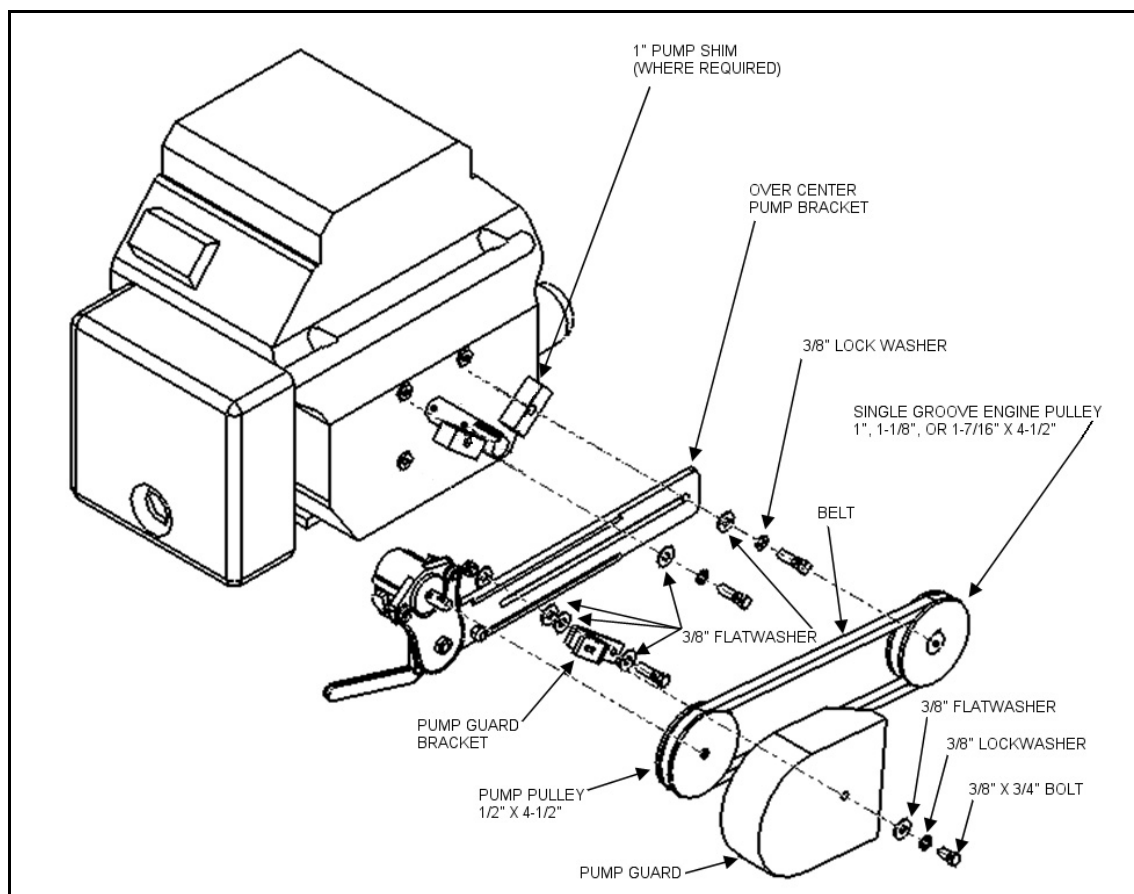


Figure 3.1 Gear Pump Installation Guard

### 3.3. OIL RESERVOIR ASSEMBLY

1. Clamp the tank mount brackets to the frame using the clamp plates and four 3/8" x 2-1/2" bolts and locknuts (Figure 3.3 and 3.2). Make sure the bolts are installed from the inside of the channel and directed outward to avoid contact with the gas tank.

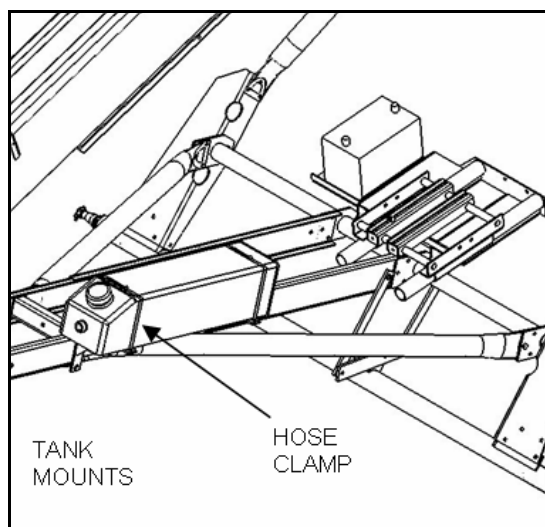


Figure 3.3 Hydraulic Reservoir Installation (1)




Figure 3.2 Hydraulic Reservoir Installation (2)



2. Secure the oil reservoir to the tank mount brackets using the hose clamps provided.
  - Do not crush the oil reservoir when tightening hose clamps.
  - Mount reservoir so that the oil level remains above the gear pump (use general purpose ISO 32 oil).
  - To reduce weight at the intake end, mount the tank as close as possible to the axle of the auger.

## 3.4. GEAR DRIVE ASSEMBLY

CAUTION	
	Before removing the wheels from the auger, ensure the auger is in the fully lowered position. Position the auger on a flat level surface and block the axle to fully support the auger while removing the wheels.

1. Remove wheels from auger.
2. Insert ring gear into rim (Figure 3.4). Use a hammer to be sure the ring gear seats evenly into the rim.
3. Tighten the 4 set screws in rotation to lock gear evenly into place.
4. Hit the ring gear with a hammer again at each set screw and retighten in rotation.
5. Put tires back on auger.

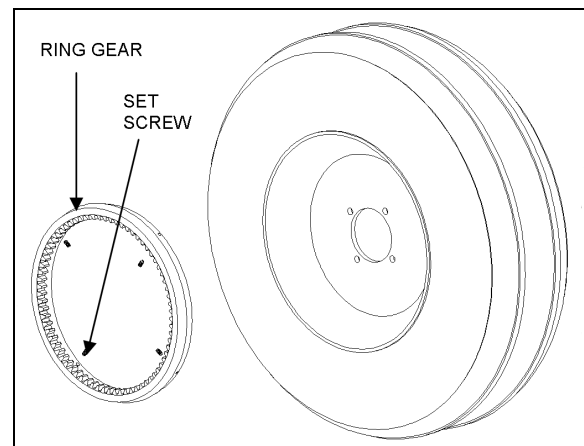


Figure 3.4 Ring Gear Installation

## 3.5. OVER-CENTER DRIVE ASSEMBLY

Once the wheel is bolted to the hub, the over-center drive assembly can be installed.

1. Bolt the over-center drive assemblies onto the axle (Figure 3.5): one LH and one RH. Use two 7/16" x 1" bolts and locknuts each side.
2. Inspect how the pinion gear fits with the ring gear (Figure 3.6).
3. Inspect the over-center drive assembly bolts to ensure that they are tight but still allow the assembly to function. Tighten as required.

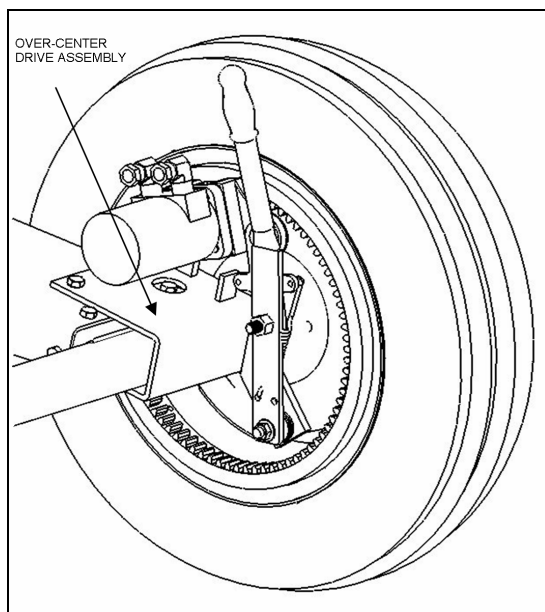


Figure 3.5 Over-Center Assembly Positioning

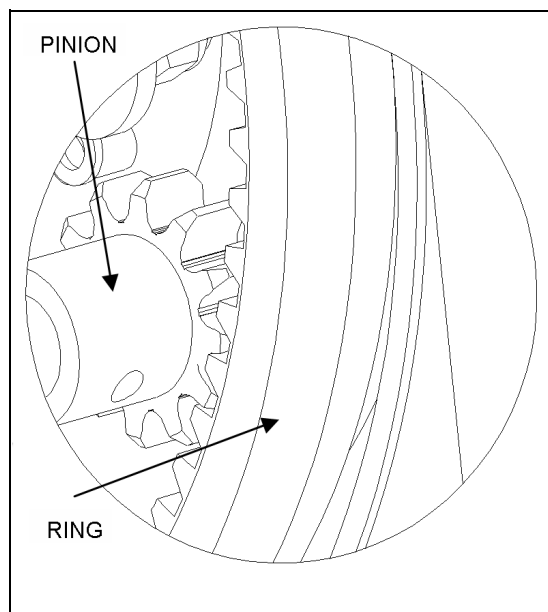


Figure 3.6 Pinion Gear Alignment

## 3.6. PINION GEAR ADJUSTMENT

### NOTICE

Failure to ensure proper gear meshing will result in gear damage.

The pinion gear should mesh with the ring gear to provide maximum tooth contact (Figure 3.6).

If the pinion gear does not mesh fully with the ring gear, adjust the handle slot bolt (which bolts to the drive mount clamp) so full meshing of pinion gear is achieved when handle is in over-center position (Figure 3.7).

**Gear teeth binding:** If the handle will not “lock” into over-center position, loosen the slot bolt nuts and slide the handle away from the tire.

**Insufficient Meshing:** If the pinion gear will barely mesh with the ring gear, loosen the slot bolt jam nuts and slide the handle towards the tire until the pinion gear teeth mesh with the ring gear teeth without binding.

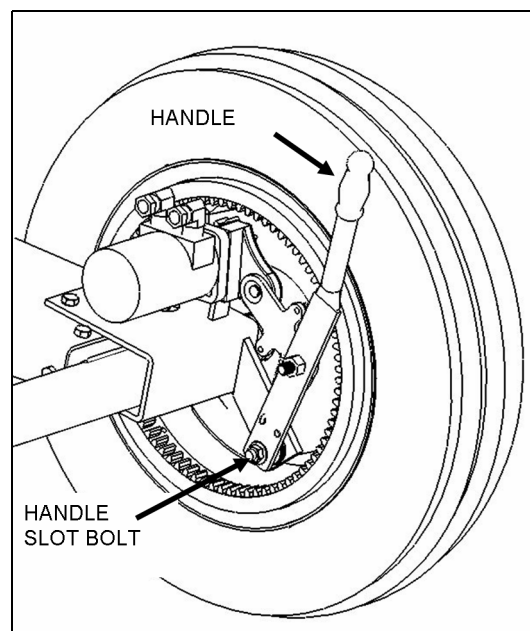
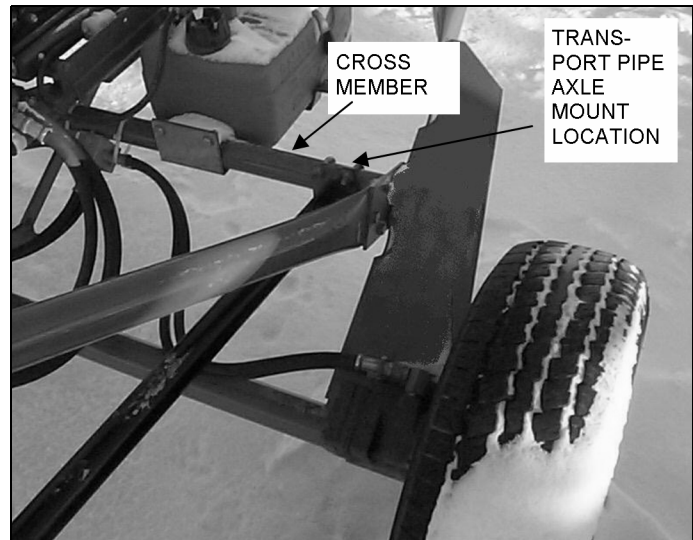


Figure 3.7 Over-Center Assembly Adjustment

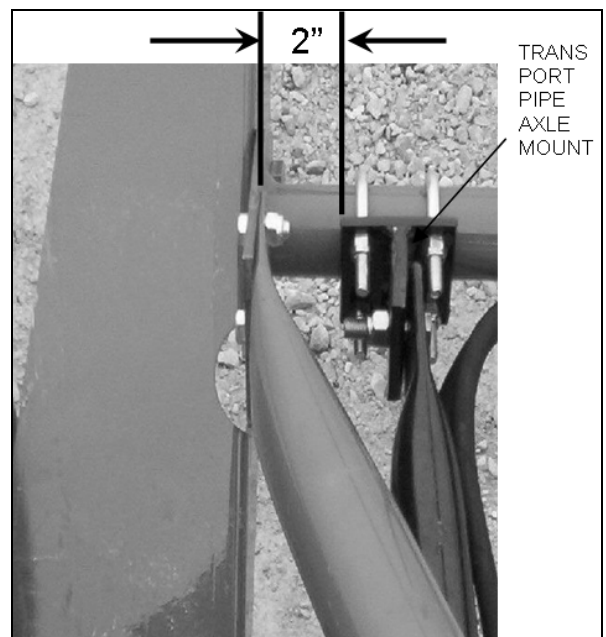
## 3.7. TRANSPORT FRAME INSTALLATION

1. Lower the auger frame completely
2. Attach the transport pipe axle mount onto the frame using  $3/8"$  x  $2"$  u-bolts and locknuts as shown in Figure 3.8 and 3.9. Space the mount  $2"$  from the end of the crossmember. Tighten the nuts and ensure that the mount is level with the ground.

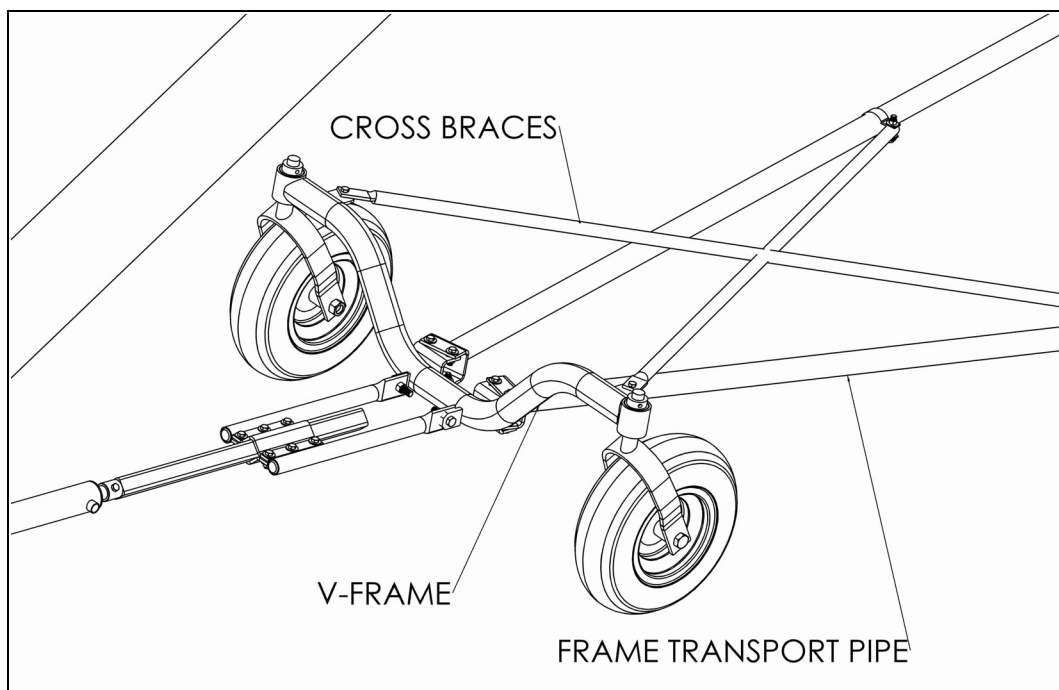


**Figure 3.8 Transport Pipe Axle Mount Location**

3. Lay the transport pipes underneath the auger frame and attach to the axle mount using a  $1/2"$  x  $2"$  bolt and locknut on each frame member. See Table 3.1 for transport pipe lengths.



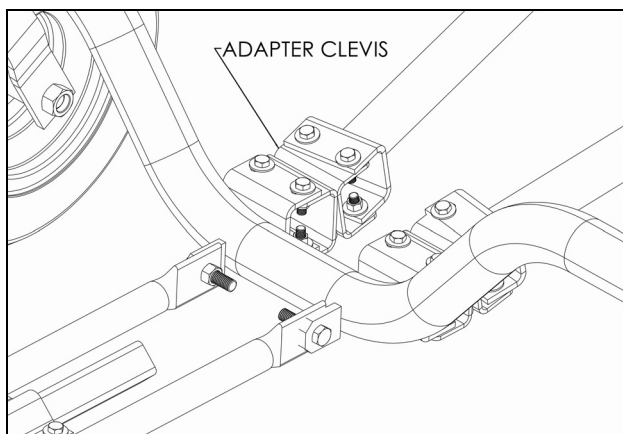
**Figure 3.9 Transport Pipe Axle Mount**



**Figure 3.10 Transport Frame Overview**

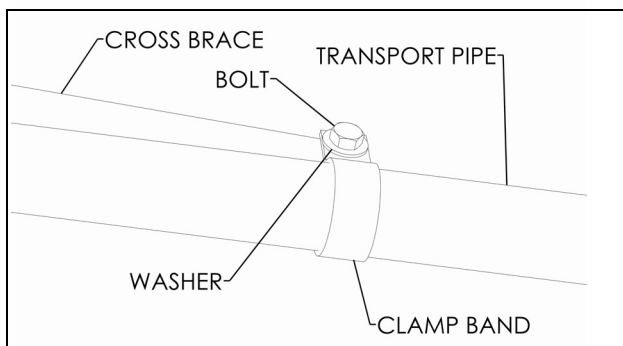
4. Attach transport pipes to wheel v-frame using eight 3/8" x 1-1/4" bolts, washers and locknuts. Ensure that the wheel v-frame is centered underneath the auger frame (Figure 3.10).

**Note:** For 8/10x31 augers, an adapter clevis between the clevis of the v-frame and the clevis of the transport pipes is used (Figure 3.11).



**Figure 3.11 Wheel V-Frame Attach Detail**

5. Attach the crossbrace pipes to the tabs on the v-frame using two 3/8" x 1-1/4" bolts and locknuts. Ensure that one crossbrace is attached at the top of the bracket and the other is underneath the bracket.
6. Install the crossbrace clamp band onto the transport pipes and attach crossbraces onto the clamp bands using two 3/8" x 2" bolts, washers and locknuts. See Figure 3.12.
7. Center and square wheel v-frame (perpendicular) to the ground before tightening all fasteners.

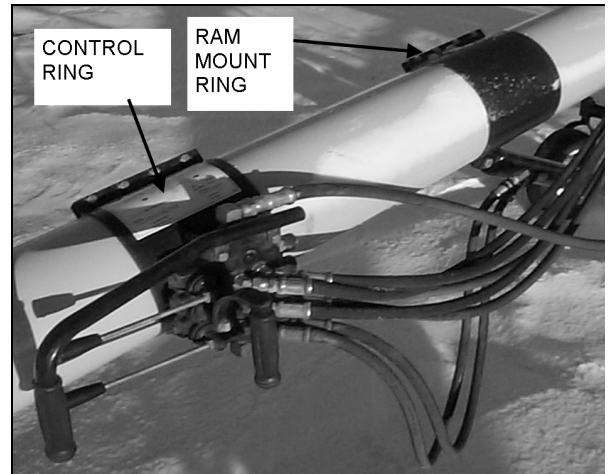


**Figure 3.12 Over-Center Assembly Adjustment**

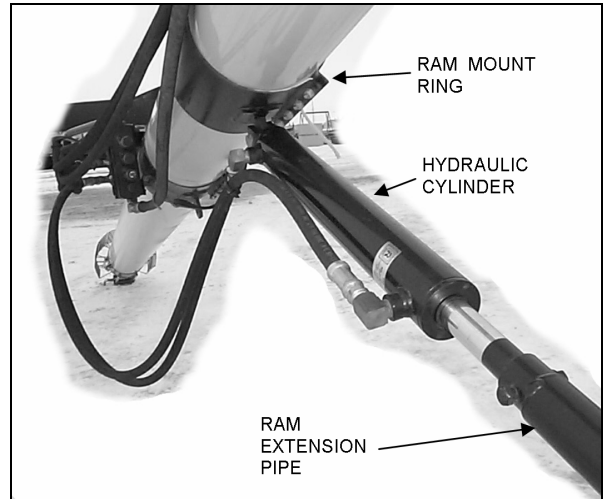
## 3.8. CONTROL RING, HYDRAULIC CYLINDER, & RAM EXTENSION INSTALLATION

Refer to Figure 3.17 and Table 3.1 for the following installation.

1. Bolt control ring and ram mount ring as two separate units using the provided tube half clamp onto auger (46' and 51') (Figure 3.13). Use eight 7/16" x 1" bolts and locknuts per clamp. Ensure that the ring is positioned so that the cylinder tab is straight down. For all other augers, the control ring and ram mount ring are mounted as one unit.
2. Attach hydraulic cylinder to the control ring (ram mount ring on 46', and 51'). Use a 1/2" x 2-1/4" bolts and locknut. Ensure auger engine is idling and the auger flighting is disengaged before moving auger (Figure 3.14).
3. For smooth auger movement, place left hand on the handle bar grip and right hand on handle bar above wheel move control. To move the auger forward/back, brace right hand against handle bar while slowly moving wheel move control.
4. Attach ram extension pipe to the fully retracted hydraulic cylinder (see Table 3.2 row "C" for ram extension length). Use a 3/8" x 2-1/2" bolt and locknut. Ensure auger engine is idling and that the auger flighting is disengaged before moving auger.

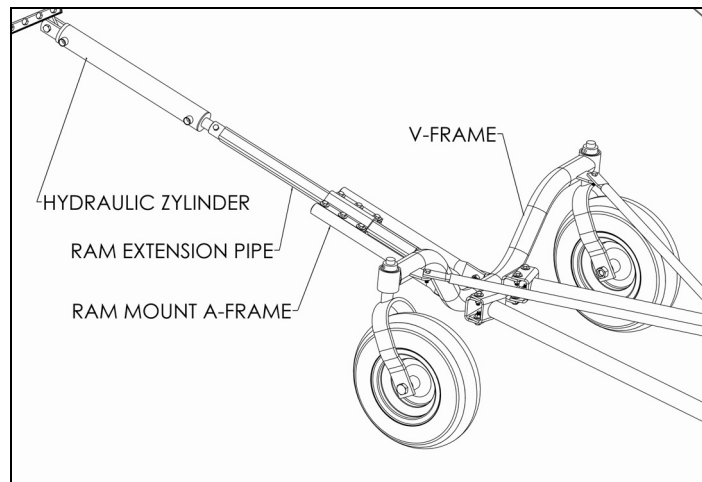


**Figure 3.13 Control Ring and Ram Mount Ring**



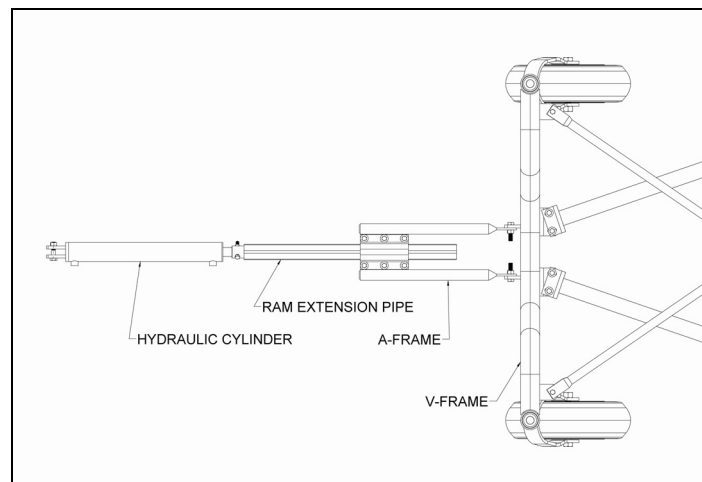
**Figure 3.14 Hydraulic Cylinder and Ram Extension**

5. Attach the ram mount a-frame onto the v-frame (Figure 3.15 and 3.16). Use 1/2" x 2" bolts and locknuts. Tighten the bolts so that the a-frame can still pivot on the tabs.

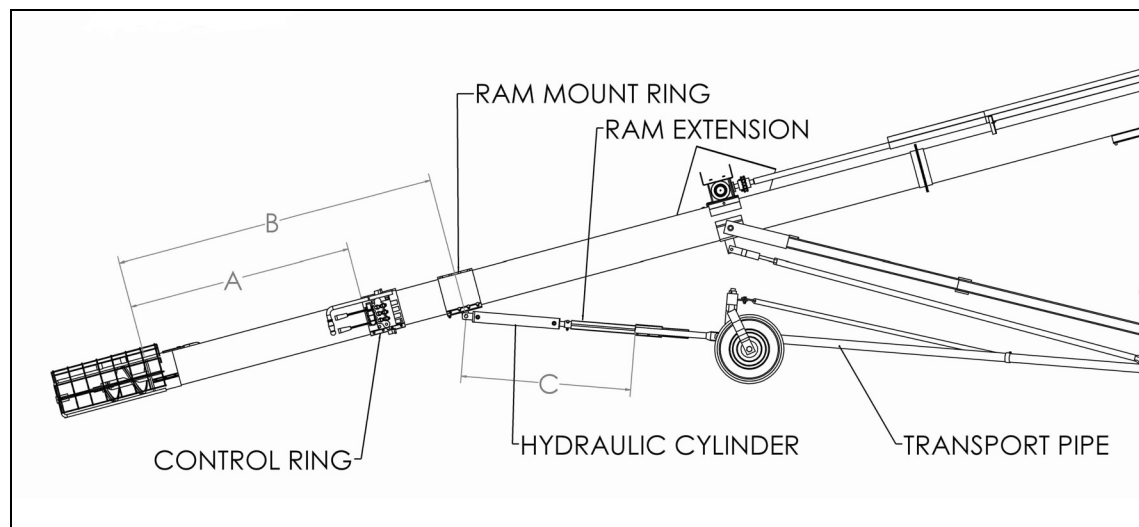


**Figure 3.15 A-Frame and Ram Extension**

6. Attach the ram extension pipe to the ram mount a-frame using six 3/8" x 1-1/4" bolts and locknuts. Leave the a-frame bolts loose (Figure 3.15 and 3.16).
7. Use a jack or other lift device to raise the v-frame, transport arm pipes, and ram assembly to form a straight line (transport position) as shown in Figure 3.17. Tighten the a-frame bolts.
8. Check that all hardware is tightened.



**Figure 3.16 Ram Extension Installation (Top View)**



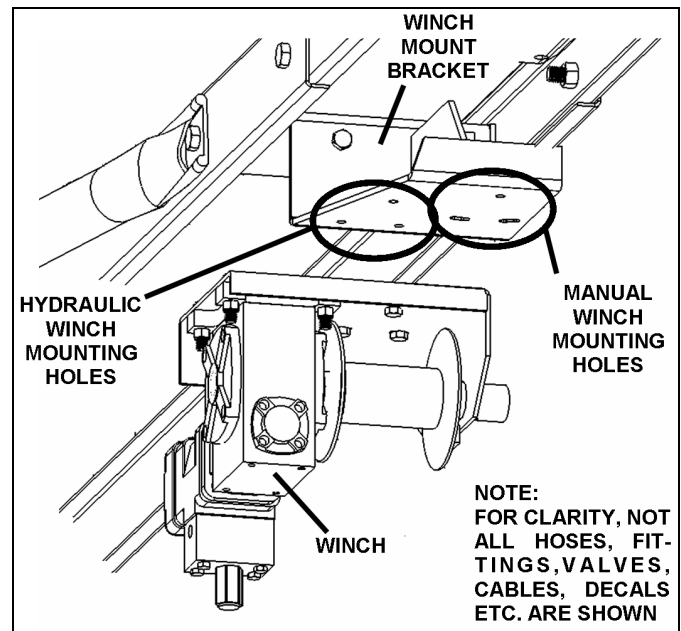
**Figure 3.17 Control Ring Installation**

**Table 3.1 Wheel Move Component Dimensions**

Auger	TFX 8 x 31	TFX 8 x 36	TFX 8 x 41	TFX 8 x 46	TFX 8 x 51	TFX 10 x 31	TFX 10 x 36"	TFX 10 x 41
A	73"	79"	80"	90"	90"	70"	65"	85"
B	67-3/4"	83"	100"	117"	127"	65"	69"	89"
C	26-1/2"	23-3/4"	43-1/4"	46"	48"	24"	24"	30"
Transport Pipe	76"	102"	120"	120"	144"	80"	102"	120"
Ram Extension	15"	15"	21"	38"	38"	15"	15"	21"

## 3.9. WINCH ASSEMBLY

- Lower auger completely and remove the hand winch on the lower auger frame.
- Attach the hydraulic winch to the winch mount using three 3/8" x 1-1/2" bolts, flat washers, and locknuts.
  - The hydraulic winch uses a different set of holes than the manual winch. See Figure 3.18.
  - The hydraulic winch drum will be centered on frame when installed properly.
- Remove cable from hand winch and install onto hydraulic winch. The cable must be wound on from the top of the winch drum (Figure 3.19).
- Tighten all hardware.
- Once hydraulic system is completed (after hoses are installed, see Section 3.10.) you will need to start the engine and slowly activate the hydraulic winch valve to take up the excess cable.



**Figure 3.18 Winch Mount**



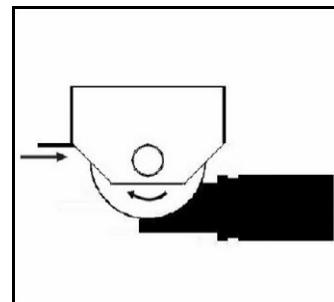
**Figure 3.19 Hydraulic Winch**

### 3.9.1. WINCH ALIGNMENT

To check the alignment of the winch, watch the cable wrapping on the drum as the auger is raised. Proper alignment is achieved when the cable indexes properly, meaning that it fills each row on the drum evenly and does not pile up against one side.

If the cable does not index properly, lower the auger fully until there is slack in the cable. Loosen the bolts on the winch. Adjust the winch, retighten nuts, and retest.

For example, if the cable is piling up to the right hand side of the drum, move the end of the winch to the left.



<b>WARNING</b>	
	<p>Falling auger hazard.</p> <p>To prevent serious injury or death while winching, ensure winch cable is fed onto the winch drum as shown above, and replace cable if frayed or damaged.</p>

### 3.10. HOSE KIT LAYOUT

Refer to Figure 3.20 and Table 3.2.

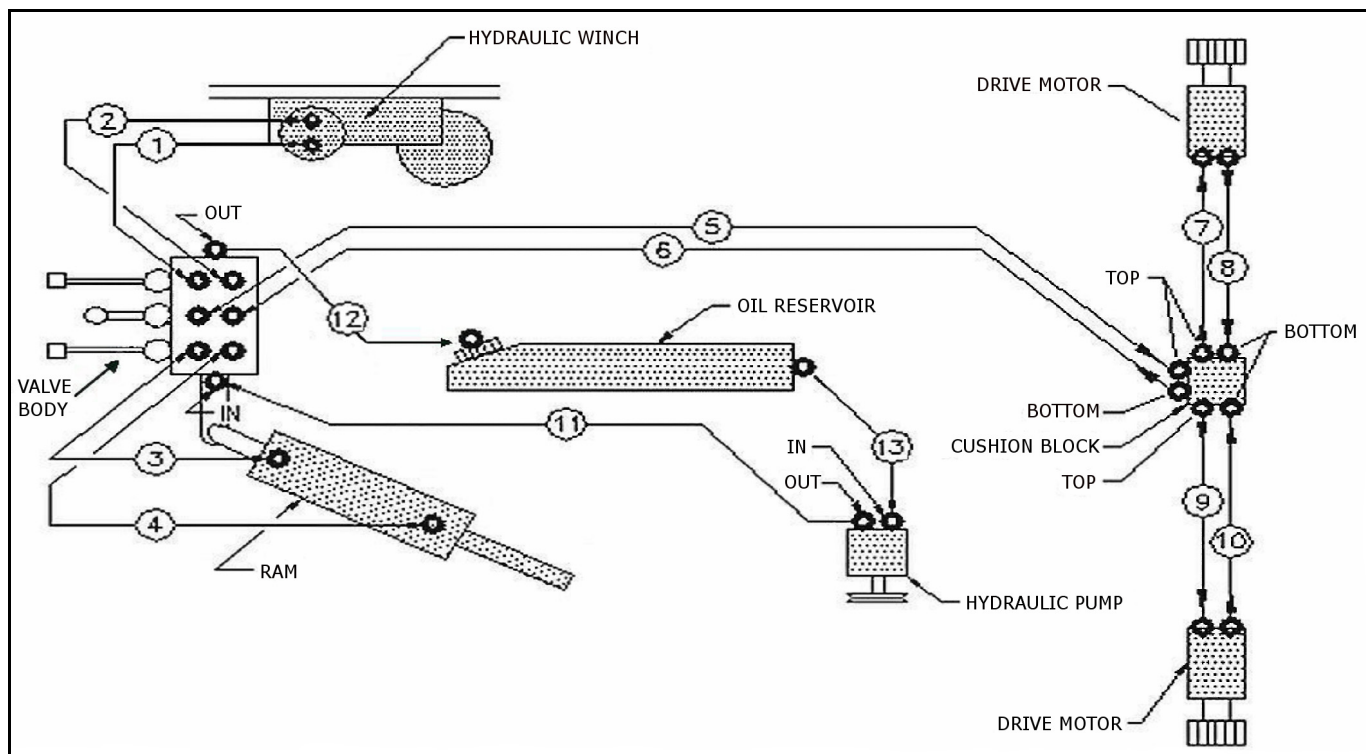


Figure 3.20 Hydraulic Schematic



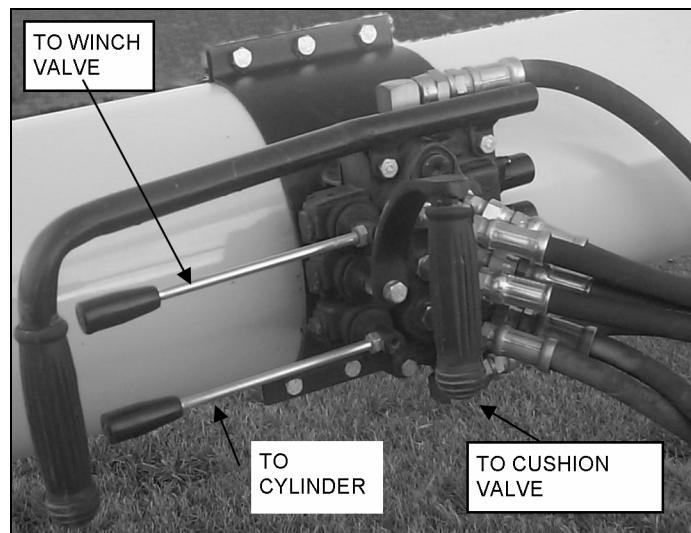
**Table 3.2 Hydraulic Hose Lengths**

HOSES	1&2	3	4	5&6	7&8	9&10	11	12	13
AUGER	Control valve to/from winch valve	Control valve to cylinder inlet port	Cylinder exit port to control valve	Control valve to/from cushion block	Cushion block to/from drive motor	Cushion block to/from drive motor	Out from hydraulic pump to control valve inlet port	Out from control valve to oil reservoir inlet	Out from oil reservoir to hydraulic pump inlet
8X31	3/8" - 96"	3/8" - 26"	3/8" - 40"	3/8" - 144"	3/8" - 48"	3/8" - 50"	1/2" - 156"	1/2" - 78"	3/4" - 48"
8X36	3/8" - 132"	3/8" - 26"	3/8" - 40"	3/8" - 177"	3/8" - 48"	3/8" - 50"	1/2" - 182"	1/2" - 94"	3/4" - 48"
8X41	3/8" - 140"	3/8" - 36"	3/8" - 52"	3/8" - 200"	3/8" - 50"	3/8" - 60"	1/2" - 214"	1/2" - 136"	3/4" - 48"
8X46	3/8" - 175"	3/8" - 44"	3/8" - 60"	3/8" - 235"	3/8" - 50"	3/8" - 60"	1/2" - 245"	1/2" - 165"	3/4" - 48"
8X51	3/8" - 200"	3/8" - 46"	3/8" - 62"	3/8" - 260"	3/8" - 50"	3/8" - 60"	1/2" - 280"	1/2" - 200"	3/4" - 48"
10X31	3/8" - 96"	3/8" - 26"	3/8" - 40"	3/8" - 144"	3/8" - 48"	3/8" - 50"	1/2" - 156"	1/2" - 78"	3/4" - 48"
10X36	3/8" - 132"	3/8" - 26"	3/8" - 40"	3/8" - 177"	3/8" - 48"	3/8" - 50"	1/2" - 182"	1/2" - 94"	3/4" - 48"
10X41	3/8" - 140"	3/8" - 36"	3/8" - 52"	3/8" - 200"	3/8" - 50"	3/8" - 60"	1/2" - 214"	1/2" - 136"	3/4" - 48"

### 3.11. HOSE KIT ASSEMBLY

Refer to Figure 3.20, 3.21, and 3.22.

1. Assemble hoses as illustrated.
2. Keep free of dirt while assembling.
3. Keep pressure and return sides aligned.
4. Tighten after being satisfied that the hoses are in the proper position.
5. Check operation.
6. Secure hoses in place with the cable ties supplied.



**Figure 3.21 Control Valve Hydraulic Hose Connections**

#### WARNING



The S.P. Transport unit **must** operate as indicated on the control panel decal. The auger **must** move in the direction that the handle is moved. **Serious operator injury** could occur if the transport unit and hydraulic hoses are not assembled correctly. If necessary, disconnect the hoses, and reassemble.

Note: Before disassembling the hoses, fully lower the auger and relieve the oil pressure.

## 3.12. CUSHION VALVE INSTALLATION

Connect the hoses as shown in Figure 3.22, ensuring that the hoses are not crossed. Connect the lower cushion valve hoses to the lower ports on each hydraulic motor as shown.

### NOTICE

Do not over-tighten fittings! Over-tightening hose fittings can crack the fittings, motor or valve body and will void the warranty.

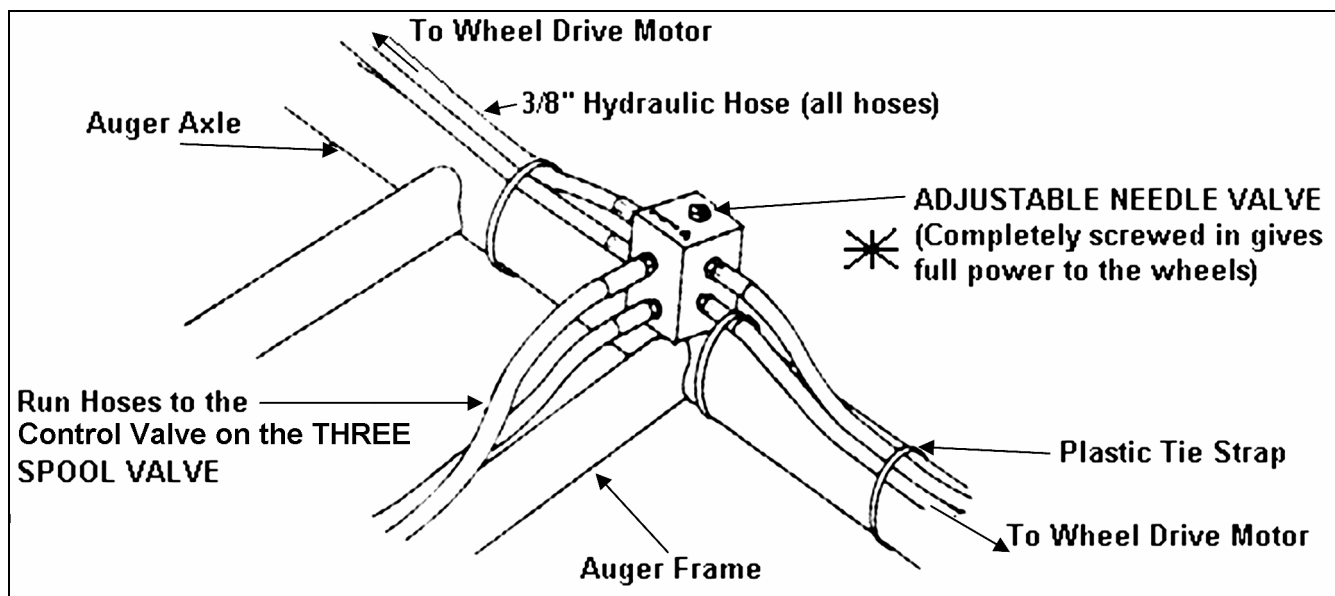


Figure 3.22 Cushion Valve Installation Schematic

# 4. Transport & Placement

**Warning:** Before continuing, ensure you have read and understand the relevant information in the safety section. Safety information is provided to help prevent serious injury, death, or property damage.

## 4.1. TRANSPORT PROCEDURE

**Note:** Use only a tractor or towing vehicle of adequate power and capacity to transport the machine.

Follow this procedure when placing the unit into its transport position:

1. If auger is raised, place in full down position with slight tension on the lift cable.
2. Attach the auger intake to the towing vehicle with a minimum 1/2" diameter pin with retainer clip and safety chain.
3. Fully raise the v-frame assembly by retracting the hydraulic cylinder. For transportation on public roadways, secure the v-frame to the auger frame to prevent it from accidentally dropping.
4. Before transporting, disengage the over-center handle at each wheel (Figure 4.1) by pulling up on the handle.

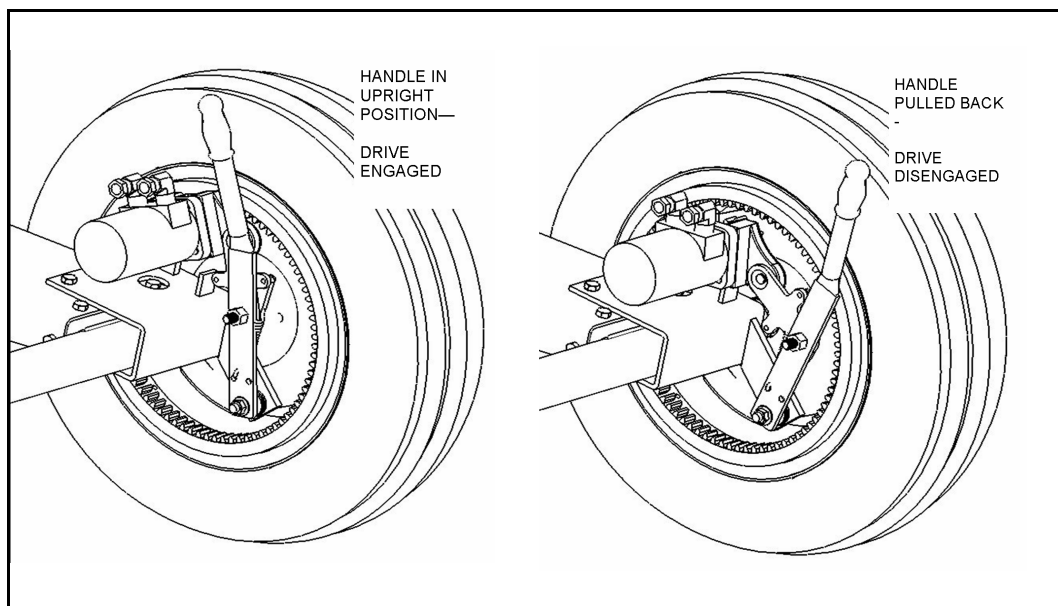


Figure 4.1 Over-Center Operating Position

### NOTICE

Ensure that the over-center bolts are tight enough to prevent the handle from engaging. If they are not tight enough, damage to the gears and motor will result.

## 4.2. PLACEMENT PROCEDURE

---

Follow this procedure when placing the machine into its working position:

1. Be sure there is enough clearance from overhead obstructions, power lines, or other equipment to move the machine into its working position.
2. Position machine in the desired area. For operation instructions, see Section 5.2.

### **WHEN PLACING UNDER HOPPER BOTTOM BINS:**

1. The wheel v-frame can easily pass through the hopper bin vertical legs.
2. The wheel v-frame does not have to travel over an obstruction.
3. Auger intake is centered between the hopper bin vertical legs so operator has adequate clearance for auger operation.
4. The auger gearbox will not contact the hopper cone when in its final position.

### **WHEN PLACING INTO FLAT BOTTOM BINS:**

1. The wheel v-frame won't contact the side of the bin when auger is in its final position.
2. The door of the bin is not obstructed.
3. The auger intake will fit through the bin access door.

# 5. Operation

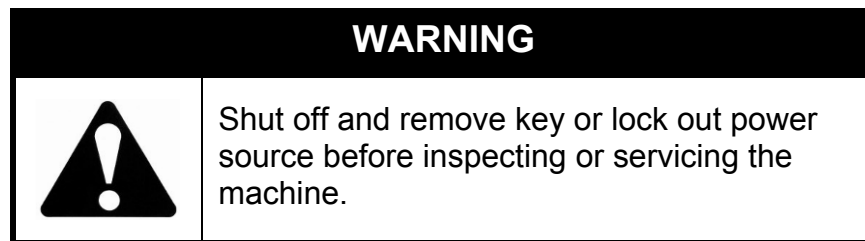
**Warning:** Before continuing, ensure you have read and understand the relevant information in the safety section. Safety information is provided to help prevent serious injury, death, or property damage.

Operators must observe safety procedures at all times and follow the pre-operational checklist before each start-up.

## Pre-Operation Checklist

Before operating each time, the operator must follow the checklist, which should confirm the following:

- Service the machine per the schedule outlined in “Maintenance Procedures” on page 33.
- Check hydraulic system oil level.
- Ensure that all hydraulic lines are free from damage, and that all fittings are tight.
- Visually inspect the unit for damage to components. Replace or repair any damaged or questionable parts.
- Check work site. Clean up working area to prevent slipping or tripping.
- Machine must be securely attached to the towing vehicle or tractor.



## 5.1. START-UP

---

Although there are no operational restrictions on the machine when used for the first time, it is recommended that the following mechanical items be checked:

### BEFORE STARTING:

- Read the operation manual.

### DURING THE FIRST FEW MINUTES OF OPERATION:

- Ensure that the unit is running properly.
- Some air may still be trapped in the hydraulic system; slowly activate all hydraulic control valves to ensure that all the air is out of the system.

### AFTER OPERATING OR TRANSPORTING FOR 1/2 HOUR:

- Re-torque all the wheel bolts (if applicable).
- Re-torque fasteners and hardware.
- Check that all guards are installed and are working as intended.

### AFTER OPERATING FOR 3 HOURS:

- Change oil in the system for best results.

### AFTER OPERATING FOR 5 AND 10 HOURS:

- Re-torque all wheel bolts (if applicable), fasteners, and hardware.
- Check all hydraulic hoses and fittings for leaks. Tighten fittings where required. Replace worn or damaged hoses.
- Check that safety decals are intact and legible. Install new ones if required.


## 5.2. OPERATING PROCEDURE

---

**Important:** *Ensure the over-center handle at each wheel is fully engaged by pushing down on the handle at each wheel and checking that the gears fully mesh (see Section 3.6. for adjustment if necessary).*

1. With the engine at idle, use the hydraulic controls (Figure 5.1 and 5.2) to fully lower the auger with the **winch control** lever on the valve before moving the auger into position.
2. Raise the auger intake end off the ground using the **hydraulic ram control** lever on the valve.
3. Move the auger into place by moving the **wheel move control** forward or backward to control the direction of travel. Steering is accomplished by grasping the **handle bar** and either leaning in or pulling away from the auger. Steering is easier if the auger is in motion.
4. When unloading a bin, aim the auger intake into the bottom of the center of the bin. Use the **winch control** lever and **hydraulic ram control** lever to help position the auger.
5. When loading a bin, use the **winch control** to raise the auger to the desired height. Use the **hydraulic ram control** to raise the intake of the auger off the ground as the auger is winched up. Turn the **wheel move control** to change the direction of travel. Leave extra clearance for making wide turns.

**Note:** *Refer to Section 6.1.2. for adjustment of the hydraulic ram speed, 6.1.1. for adjustment of the wheel drive speed, and 6.1.4. for winch valve kick out.*

CAUTION	
	Do not attempt to move the auger on uneven or hilly terrain. The mover will not perform well under these conditions and could damage the machine or injure the operator.

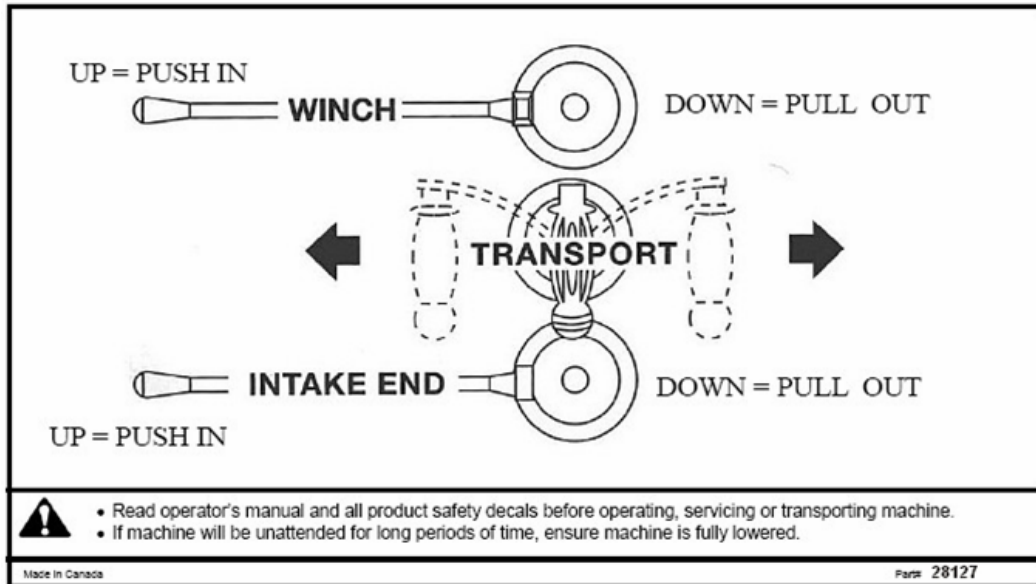


Figure 5.1 Hydraulic Control Decal

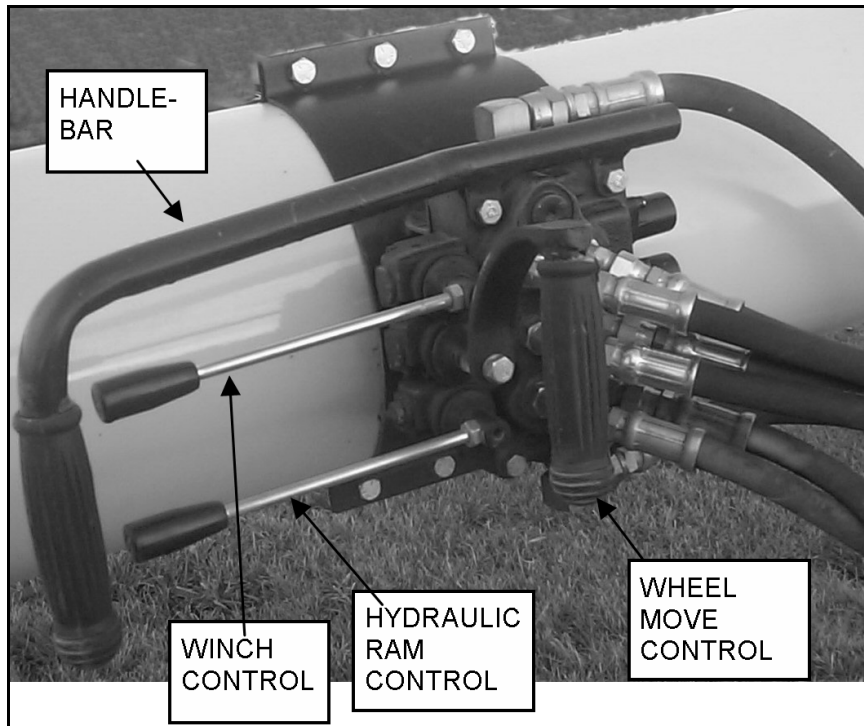


Figure 5.2 Hydraulic Controls





# 6. Maintenance and Storage

**Warning:** Before continuing, ensure you have read and understand the relevant information in the safety section. Safety information is provided to help prevent serious injury, death, or property damage.

## 6.1. MAINTENANCE PROCEDURES

---

Before performing any maintenance on this unit, shut off and remove key or lock out power source.

1. Periodically check for wear and proper meshing of the ring gear and pinion. See "Pinion Gear Adjustment" on page 18.
2. Change oil annually to remove any accumulation of dirt or condensation in the system. Replace with Type A automatic transmission oil. Do not overfill reservoir. Leave 1/2 quart (0.47L) space to allow for level fluctuation.
3. Inspect hoses and fittings. Replace as required.
4. Inspect ring and pinion gears. Replace if worn.

### 6.1.1. HYDRAULIC WINCH VALVE

---

The hydraulic winch option allows the operator to safely and easily lower and raise the auger.

The winch is equipped with a factory preset safety valve that allows the winch to completely raise the auger, but it will stop once the auger is fully raised.

The safety valve is non-adjustable and does not require any maintenance.

The only item that an operator must inspect is the cable, and if this cable is frayed or worn, it must be replaced.

**Important:** *Winch speed is adjusted at the factory. Cold temperatures may cause the winch to operate slowly.*

#### WARNING



Winch cable must be wound onto the drum of the winch from the top of the drum. This ensures the safe and proper operation of the hydraulic winch.

## 6.1.2. RAM SPEED ADJUSTMENT

Ram speed is regulated at the control valve. The adjustable stroke limiter screws and locknuts that set the speed of the ram travel individually in each direction (Figure 6.1).

Adjust the stroke limiter screws and locknuts until the desired rate of travel is achieved.

- Turning the screws inward results in a slower speed
- Turning the screws outward results in a faster speed

**Note:** *All spools are of a special metering design which allows more precision in maneuverability.*

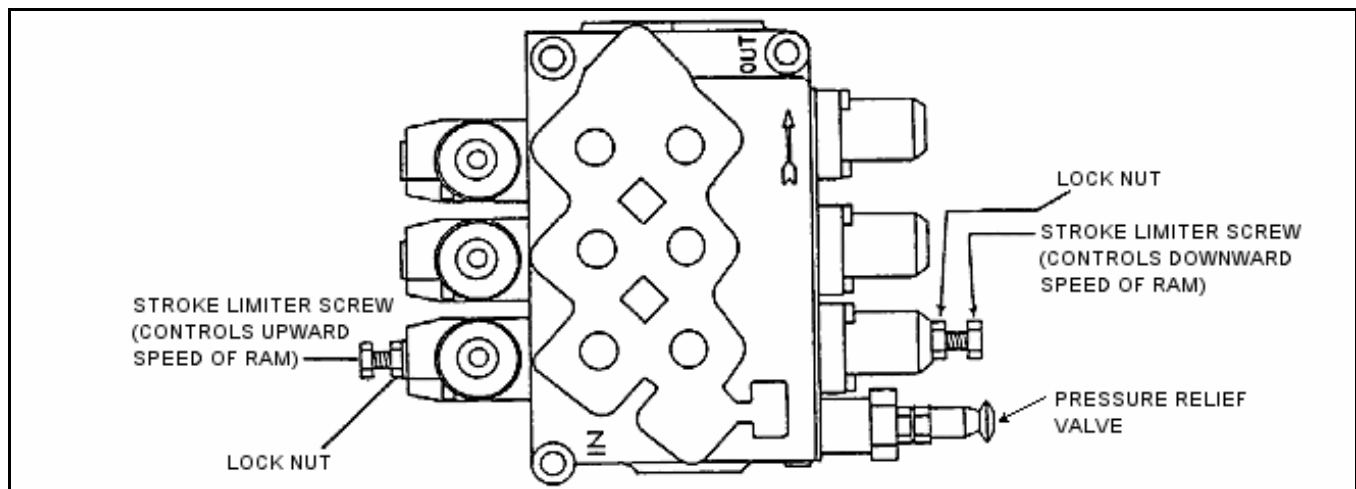


Figure 6.1 Valve Adjustment

## 6.1.3. HYDRAULIC PRESSURE RELIEF VALVE ADJUSTMENT

**Note:** *Before adjusting, ensure auger is fully lowered (intake and discharge ends) and that the auger is on a level surface.*

If the controls are “jerky” or act too fast, it may be necessary to increase the hydraulic pressure on the self-propelled auger kit. To do this, follow the steps below and refer to Figure 6.1.

1. Ensure auger engine is idling and that the auger flighting is disengaged before adjusting.
2. **To decrease hydraulic pressure:** loosen jam nut on 3 spool valve (bottom right side of valve) and turn adjustment screw out (counter-clockwise) 1/4 turn. Tighten jam nut.
3. **To increase hydraulic pressure:** repeat step 2. except turn adjustment screw in (clockwise) 1/4 turn. Tighten jam nut.

## 6.1.4. CUSHION VALVE ADJUSTMENT

To control the speed of the mover, the adjustable needle valve (Figure 6.2) can be:

- screwed in for increased speed (adjust by 1/8 turn increments)
- screwed out for decreased speed (adjust by 1/8 turn increments)

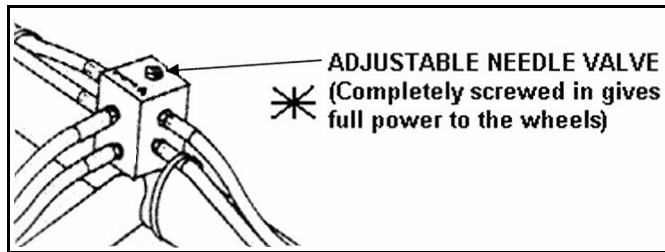


Figure 6.2 Cushion Valve Adjustment

## 6.2. STORAGE PROCEDURES

---

For long, trouble-free life, prepare unit for storage after the season's use.

- Lock out all power.
- Store the machine on a level surface, free of debris, and in an area away from human activity. Store in a dry place, or use a tightly secured tarp to protect the equipment from the weather.
- Place unit in transport position.
- Remove all residual material and clean the machine thoroughly.
- Inspect the unit at stress points for cracks.
- Repair or replace any worn or damaged components to prevent any unnecessary downtime at the start of the next season.
- Touch up paint nicks and scratches to prevent rusting.
- Check hydraulic fittings, hoses, lines, couplers, and valves. Tighten any loose fittings. Replace any hose that is badly cut, nicked, abraded, or is separating from the crimped end of the fitting. Secure the hoses to the machine.
- Inspect and tighten all fasteners; replace fasteners if required.
- Check tire inflation.
- Retract all cylinders or grease exposed shafts.
- Inspect hydraulic cylinders for leaks; replace seals if necessary



# 7. Troubleshooting

PROBLEM	CAUSE	SOLUTION
Valve is leaking.	• loose/cracked fittings	• tighten/replace fittings
	• worn hose	• replace hose
	• valve spools are worn	• replace valve
Machine operates slowly.	• oil is hot	• check oil level and add oil if required (use general purpose ISO 32 hydraulic oil)
	• blockage in hydraulic lines	• suction hose blocked or kinked
	• power source is not producing enough oil volume and/or pressure	• speed up the engine to produce more flow/pressure • the power unit may not have enough capacity to operate properly
	• cushion block needs adjusting	• adjust valve on cushion block by turning inward 1/8 of a turn at a time, refer to “Cushion Valve Adjustment” on page 34
	• Filter plugged (if equipped)	• Change filter.
Hydraulic winch will not raise auger.	• relief valve pressure set too low	• adjust relief valve pressure, refer to “Hydraulic Pressure Relief Valve Adjustment” on page 34
	• oil level is too low	• check oil level
	• pump is worn out	• replace pump
Hydraulic cylinder leaking.	• worn seal	• replace seal
Winch coupler spins off (Dutton winch).	• internal winch parts worn	• replace worn parts
	• damage or obstruction on tracking	• check tracking for damage or obstructions
Auger doesn't drive.	• cushion block needs adjusting	• adjust needle valve by turning clockwise 1/8 of a turn - try and repeat if necessary, refer to “Cushion Valve Adjustment” on page 34.
Pinion gear slipping or binding.	• pinion gear not adjusted properly	• Adjust the pinion gear. See “Pinion Gear Adjustment” on page 18.



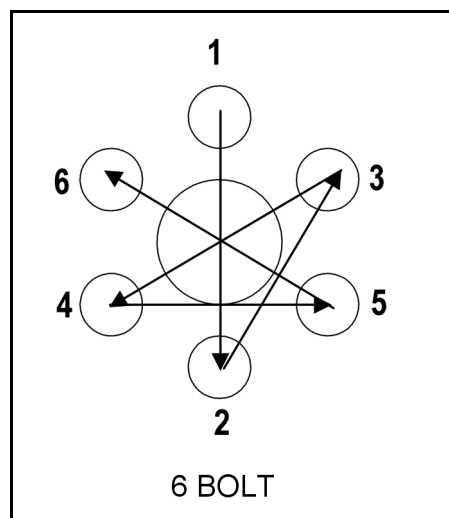
# 8. Appendix

## 8.1. BOLT TORQUE VALUES

The tables shown below give correct torque values for various bolts and capscrews. Tighten all bolts to the torque specified in the chart unless otherwise noted. Check tightness of bolts periodically, using bolt torque chart as your guide. Replace hardware with the same strength bolt.

**Table 8.1 Imperial Bolt Torque**

BOLT DIAMETER	SAE 2		SAE 5		SAE 8	
	(Nm)	(lb-ft)	(Nm)	(lb-ft)	(Nm)	(lb-ft)
1/4"	8	6	12	9	17	12
5/16"	13	10	25	19	36	27
3/8"	27	20	45	33	63	45
7/16"	41	30	72	53	100	75
1/2"	61	45	110	80	155	115
9/16"	95	60	155	115	220	165
5/8"	128	95	215	160	305	220
3/4"	225	165	390	290	540	400
7/8"	230	170	570	420	880	650
1"	345	225	850	630	1320	970



**Figure 8.1 Pattern for Tightening Wheel Bolts**

**Table 8.2 Metric Bolt Torque**

BOLT DIAMETER	8.8		10.9	
	(Nm)	(lb-ft)	(Nm)	(lb-ft)
M3	0.5	0.4	1.8	1.3
M4	3	2.2	4.5	3.3
M5	6	4	9	7
M6	10	7	15	11
M8	25	18	35	26
M10	50	37	70	52
M12	90	66	125	92
M14	140	103	200	148
M16	225	166	310	229
M20	435	321	610	450
M24	750	553	1050	774
M30	1495	1103	2100	1550
M36	2600	1917	3675	2710

Torque figures indicated above are valid for non-greased or non-oiled threads and head unless otherwise specified. Therefore, do not grease or oil bolts or capscrews unless otherwise specified in this manual. When using locking elements, increase torque values by 5%.

## 8.2. TIGHTENING O-RING FITTINGS

1. Inspect o-ring and seat for dirt or obvious defects.
2. On the angle fittings, back the lock nut off until washer bottoms out at top of groove.
3. Hand-tighten fitting until back up washer or washer face (if straight fitting) bottoms on face and o-ring is seated.
4. Position angle fittings by unscrewing no more than one turn.
5. Tighten straight fittings to torque shown.
6. Tighten while holding body of fitting with a wrench.



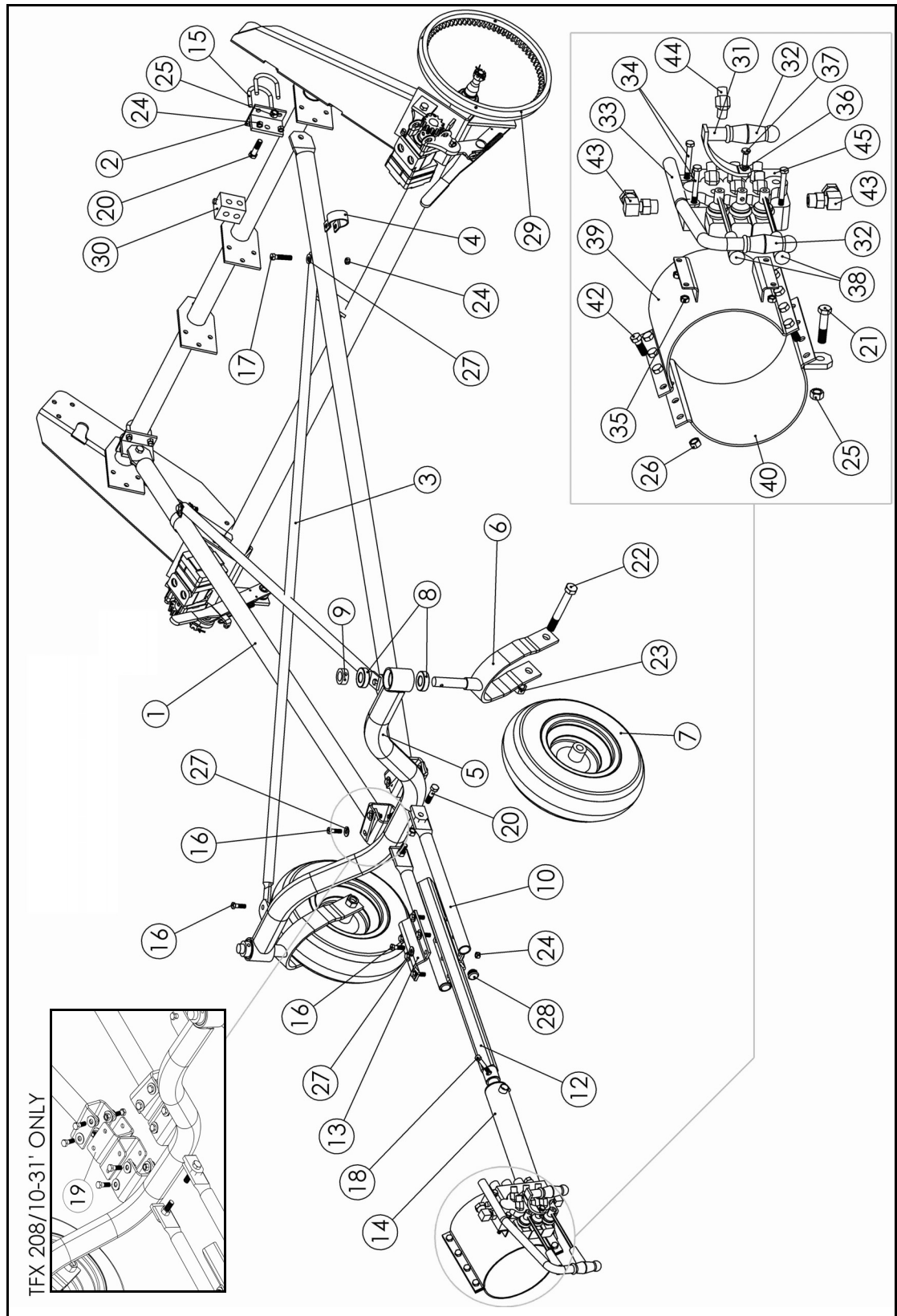
**Table 8.3 “O” Ring Fittings**

<b>Tube Size OD (in.)</b>	<b>Nut Size Across Flats (in.)</b>	<b>Torque Values<sup>a</sup> (Nm)</b>	<b>Torque Values<sup>a</sup> (Lb-ft)</b>	<b># of Turns to Tighten (Flats)</b>	<b>(After Finger Tightening) (Turn)</b>
3/8	1/2	8	6	2	1/3
7/16	9/16	12	9	2	1/3
1/2	5/8	16	12	2	1/3
9/16	11/16	24	18	2	1/3
3/4	7/8	46	34	2	1/3
7/8	1	62	46	1-1/2	1/4
1-1/16	1-1/4	102	75	1	1/6
1-3/16	1-3/8	122	90	1	1/6
1-5/16	1-1/2	142	105	3/4	1/8
1-5/8	1-7/8	190	140	3/4	1/8
7/8	2-1/8	217	160	1/2	1/12

a. The torque values shown are based on lubricated connections as in reassemble.

## 8.3. PARTS

### 8.3.1. SELF-PROPELLED AUGER KIT



ITEM NO.	PART NO.	DESCRIPTION	QTY
1	28195	TRANSPORT FRAME PIPE, 76" (8-31')	1
1A	29811	TRANSPORT FRAME PIPE, 80" (10-31')	1
1B	28196	TRANSPORT FRAME PIPE, 102" (8/10-36')	1
1C	28197	TRANSPORT FRAME PIPE, 120" (8/10-41', 8-46')	1
1D	28198	TRANSPORT FRAME PIPE, 144" (31')	1
2	27942	WHEEL MOVE BRACKET	2
3	0200320	CROSS BRACE PIPE	2
4	0200321	CROSS BRACE, CLAMPBAND (2") (8/10-31'/36'/41', 8-46')	2
4A	27242	CROSS BRACE, CLAMPBAND (2.5") (8-51')	2
5	28167	WHEEL V FRAME ASSY, NARROW, W/ BRGS	1
6	0200314	WHEEL YOKE W/ COLLAR	2
7	28169	WHEEL AND TIRE	2
8	0200006	1" ID BALL BEARING	4
9	9900248	LOCKING COLLAR, 1"	2
10	29748	2012 RAM MOUNTING A-FRAME	1
12	29741	RAM EXTENSION PIPE, 15" (8/10-31'/36')	1
12A	29742	RAM EXTENSION PIPE, 21" (8/10-41')	1
12B	29744	RAM EXTENSION PIPE, 38" (8-51')	1
13	29747	RAM MNT A-FRAME CLAMP	1
14	200308	CYL,2 X 15.625 X 1.125 ROD,1 @ END	1
15	19609	U-BOLT, 3/8" x 2"	4
16	19975	BOLT, 3/8" x 1 1/4" GR5 PLTD	27
17	27979	BOLT, 3/8" x 2" GR5 PLTD	2
18	18699	BOLT, 3/8" x 2 1/2" GR5 PLTD	5
19	29808	ADAPTER CLEVIS	2
20	27816	BOLT, 1/2" x 2" GR5 PLTD	4
21	9900560	BOLT, 1/2" x 2-1/4" GR5 PLTD	1
22	28263	BOLT, 3/4" x 6" GR5 PLTD	2
23	19601	NYLON LOCKNUT, 3/4" PLTD	2
24	17402	NYLON LOCKNUT, 3/8" PLTD	41
25	19599	LOCKNUT, 1/2" PLTD	5
26	19598	NYLON LOCKNUT, 7/16" PLTD	26
27	17392	FLAT WASHER, 3/8"	62
28	9900339	1" ROUND POLY PLUG	2

ITEM NO.	PART NO.	DESCRIPTION	QTY
29	0200334	RING GEAR W/ SET SCREWS	2
30	0200350	CUSHION BLOCK, COMPLETE	1
31	0200303	CONTROL HANDLE W/ GRIP	1
32	020007-4	HANDLE GRIP	2
33	0200305	BAR HANDLE W/ GRIP	1
34	19965	BOLT, 5/16" x 2-3/4" GR2 PLTD	3
35	19980	NYLON LOCKNUT, 5/16" PLTD	3
36	19603	LOCKWASHER, 5/16	"1
37	9900852	BOLT HEX M8 x 1.25" GR8.8 PLT	1
38	1600007	CONTROL LEVER, SD5 VALVE	2
39A	29756	8" HALF CLAMP, VALVE MOUNT, (8" WIDE)	1
39B	29775	10" HALF CLAMP, VALVE MOUNT, (8" WIDE)	1
40A	29749	8" HALF CLAMP RAM MOUNT (8" WIDE)	1
40B	29774	10" HALF CLAMP RAM MOUNT (8" WIDE)	1
41A	29750	8" HALF CLAMP (8" WIDE) (NOT SHOWN)	2
41B	29773	10" HALF CLAMP (8" WIDE) (NOT SHOWN)	2
42	18698	BOLT, 7/16" x 1" GR5 PLTD	20
43	28184	FTG ELB, 1/2" MNPT TO 3/8" FSW	2
44	28504	FTG ELB 45°, 6MORB x 6MJIC	6
45	1600006	3 SPOOL VALVE, 2 HANDLES, NO FTGS	1

# WARRANTY

Westfield Industries Ltd. warrants products of its manufacture against defects in materials or workmanship under normal and reasonable use for a period of one year after date of delivery to the original purchaser.

Our obligation under this warranty is limited to repairing, replacing, or refunding defective part or parts which shall be returned to a distributor or a dealer of our Company, or to our factory, with transportation charges prepaid. This warranty does not obligate Westfield Industries Ltd. to bear the cost of labor in replacing defective parts. Any defects must be reported to the Company before the end of the one year period.

This warranty shall not apply to equipment which has been altered, improperly assembled, improperly maintained, or improperly repaired so as to adversely affect its performance. Westfield Industries Ltd. makes no express warranty of any character with respect to parts not of its manufacture.

The foregoing is in lieu of all other warranties, expressed or implied, including any warranties that extend beyond the description of the product, and the IMPLIED WARRANTY of MERCHANTABILITY is expressly excluded.

WESTFIELD INDUSTRIES LTD.

ROSENORT, MANITOBA

CANADA

ROG 1W0

# **WESTFIELD**

Westfield Industries

Part of the Ag Growth International Inc. Group

P.O. Box 39

Rosenort, Manitoba, Canada R0G 1W0

Phone: (866) 467-7207 (Canada & USA)

Fax: (866) 768-4852

website: [www.grainaugers.com](http://www.grainaugers.com)

email: [sales@grainaugers.com](mailto:sales@grainaugers.com)

© Ag Growth International Inc. 2013



Printed in Canada