

Chapter 1



What is Politics?

- 
- 'Man by nature a political animal'.

Aristotle *Politics*, 1.

- Politics exists because people disagree.
- For Aristotle, politics is 'nothing less than the activity through which human beings attempt to improve their lives and create the Good Society. Politics is a social activity. It is always a dialogue, and never a monologue.

Defining politics



- Politics in its broadest sense, is the activity through which people make, preserve and amend the general rules under which they live.
- Politics is inextricably linked to the phenomena of *conflict* and *cooperation*.

- 
- On the one hand, the existence of rival opinions, different wants, competing needs and opposing interests guarantees disagreement about the rules under which people live.
 - On the other hand, people recognise that in order to influence these rules or ensure that they are upheld, they must work with others.

- 
- Two major problems on clarifying the meaning of politics.
 1. Few people come to politics without preconceptions. Many automatically assume that students and teachers of politics must in some way be biased, finding it difficult to believe that the subject can be approached in an impartial and dispassionate manner.



2. Politics is defined in such different ways as the exercise of power, the exercise of authority, the making of collective decisions, the allocation of scarce resources, the practice of deception and manipulation, and so on.

- Politics may be treated as a essentially contested concept in the sense that the term has a number of acceptable or legitimate meanings.



The different views of politics examined here are as follows.

- Politics as the art of government
- Politics as public affairs
- Politics as compromise and consensus.
- Politics as power and the distribution of resources.

Politics as the art of government

- 'Politics is not a science...but an art'.

Chancellor Bismarck

- The art Bismarck had in mind was the art of government, the exercise of control within society through the making and enforcement of collective decisions.



- 
- US political scientist David Easton defines politics as the '*authoritative allocation of values*'. By this he means that politics encompasses the various processes through which government responds to pressures from the larger society, in particular by allocating benefits, rewards or penalties. '*Authoritative values*' are therefore ones that are widely accepted in society, and are considered binding by the mass of citizens.

- 
- Politics is what takes place within a *polity*, a system of social organisation centred upon the machinery of government. Politics is therefore practised in cabinet rooms, legislative chambers, government departments and the like, and it is engaged in by a limited and specific group of people, notably politicians, civil servants and lobbyists.

Cabinet Office



British Cabinet Room

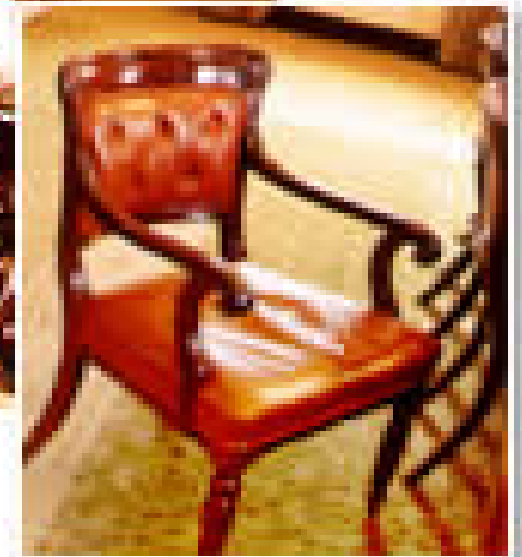

Click here to view
The Cabinet Room in panorama

Governance



- Governance is a broader term than government. Although it still has no settled or agreed definition, it refers, in its widest sense, to the various ways through which social life is coordinated. Government can therefore be seen as one of the institutions involved in governance. It is possible to have governance without government.
- The principal modes of governance are markets, hierarchies and networks. The wider use of the term reflects a blurring of the state/society distinction, resulting from changes such as the development of new forms of public management, the growth of public-private partnerships, the increasing importance of policy networks, and the greater impact of both supranational and sub-national organisations.

Politics as Public Affairs



- A second broader conception of politics moves it beyond the narrow realm of government to what is thought of as 'public life' or 'public affairs'.
- Where should the line between 'public' life and 'private' life be drawn? The traditional distinction between the *state* and *civil society*.

Two views of the public/private divide

Public	Private
The state: apparatus of government	Civil society: autonomous bodies: businesses, trade unions, clubs, families, and so on

Public	Private
Public realm: politics, commerce, work, art, culture, and so on	Personal realm: family and domestic life

Politics as Compromise and Consensus



- The third conception of politics relates not so much to the arena within which politics is conducted as to the way in which decisions are made. Specifically, politics is seen as a particular means of resolving conflict: that is, by compromise, conciliation and negotiation, rather than through force and naked power.
- This is what is implied when politics is portrayed as '*the art of the possible*'.

Politics as Power



- Power in its broadest sense, is *the ability to achieve a desired outcome*, and it is sometimes referred to in terms of the power to do something.
- In politics, power is usually thought of as *a relationship*: that is, as *the ability to influence the behaviour of others in a manner not of their choosing*.

Approaches to the study of politics

- The philosophical tradition (perspective/normative)

This involves the analytical study of ideas and doctrines that have been central to political thought. Most commonly, it has taken the form of a history of political thought that focuses on a collection of 'major' thinkers (that spans, e.g. Plato to Marx) and a canon of 'classic' texts.

The 'normative' approach is 'prescriptive' in the sense that it *makes judgements and offers recommendations*.



- The empirical tradition

The empirical approach to political analysis is characterised by the attempt to offer a dispassionate and impartial account of political reality.

The approach is 'descriptive' in that it seeks to *analyse and explain*.

- 
- The scientific tradition
 - Objective and quantifiable data against which hypotheses could be tested.
 - concepts such as 'liberty', 'equality', 'justice' and 'rights' are sometimes discarded as being meaningless because they are not empirically verifiable entities.

- 
- Recent developments
 - Amongst recent theoretical approaches to politics is what is called formal political theory, variously known as '*political economy*', '*public choice theory*' and '*rational-choice theory*'.
 - This approach to analysis draws heavily upon the example of *economic theory* in building up models based upon procedural rules, usually about the rationally self-interested behaviour of the individuals involved.

Can the study of politics be scientific?



Three difficulties:

1. The problem of data.
2. The existence of hidden values.
3. The myth of neutrality in the social science.

Concepts, models and theories

- A *concept* is a general idea about something, usually expressed in a single word or a short phrase. A concept is more than a proper noun or the name of a thing.
- Models and theories are broader than concepts; they comprise a range of ideas rather than a single idea.
- The purpose of a model is to resemble the original object as faithfully as possible.

- 
- Conceptual models are analytical tools; their value is that they are devices through which meaning can be imposed upon what would otherwise be a bewildering and disorganised collection of facts.
 - It is vital to remember that conceptual models are at best simplifications of the reality they seek to explain.
 - The terms theory and model are often used interchangeably in politics. Theories and models are both conceptual constructs used as tools of political analysis.

The Political System model by David Easton (1979)

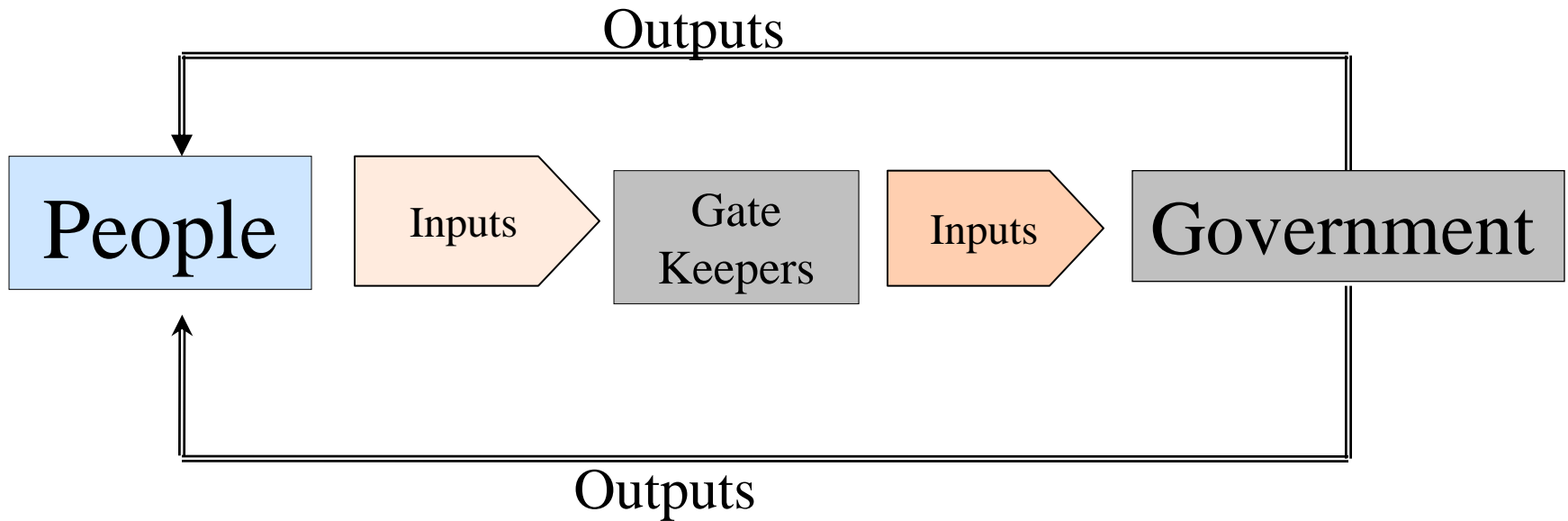

Levels of Conceptual Analysis

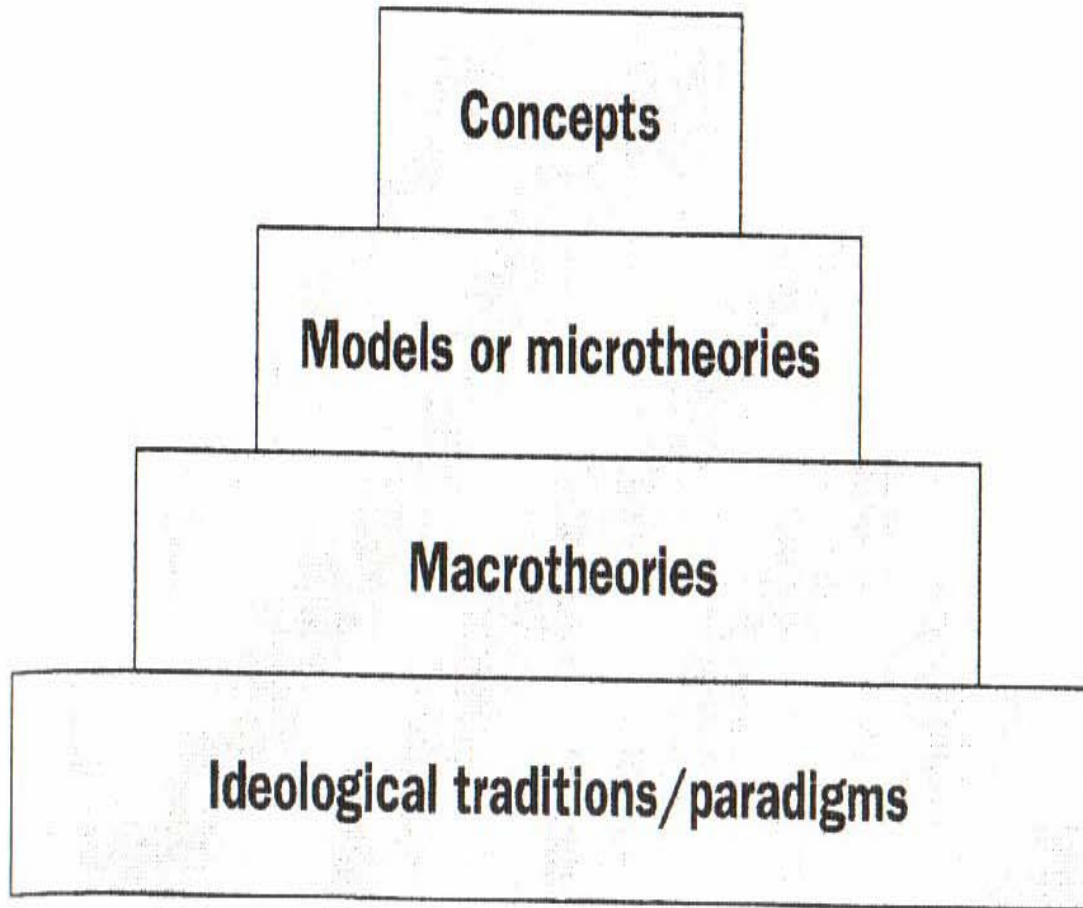

Examples: power, social class, rights, law

Examples: systems analysis, public choice, game theory

Examples: pluralism, elitism, functionalism

Examples: liberalism, Marxism, feminism