

Data Communications & Networks

**Session 5 – Main Theme
Wireless and Mobile Networks**

Dr. Jean-Claude Franchitti

*New York University
Computer Science Department
Courant Institute of Mathematical Sciences*

*Adapted from course textbook resources
Computer Networking: A Top-Down Approach, 5/E
Copyright 1996-2009
J.F. Kurose and K.W. Ross, All Rights Reserved*

Agenda



- 1 Session Overview**
- 2 Wireless and Mobile Networks**
- 3 Summary and Conclusion**

2



- Course description and syllabus:

- » <http://www.nyu.edu/classes/jcf/g22.2262-001/>
- » <http://www.cs.nyu.edu/courses/spring10/G22.2262-001/index.html>

- Textbooks:

- » **Computer Networking: A Top-Down Approach (5th Edition)**



James F. Kurose, Keith W. Ross
Addison Wesley

ISBN-10: 0136079679, ISBN-13: 978-0136079675, 5th Edition (03/09)



- Computer Networks and the Internet
- Application Layer
- Fundamental Data Structures: queues, ring buffers, finite state machines
- Data Encoding and Transmission
- Local Area Networks and Data Link Control
- Wireless Communications
- Packet Switching
- OSI and Internet Protocol Architecture
- Congestion Control and Flow Control Methods
- Internet Protocols (IP, ARP, UDP, TCP)
- Network (packet) Routing Algorithms (OSPF, Distance Vector)
- IP Multicast
- Sockets

Background:

- # wireless (mobile) phone subscribers now exceeds # wired phone subscribers!
- computer nets: laptops, palmtops, PDAs, Internet-enabled phone promise anytime untethered Internet access
- two important (but different) challenges
 - » *wireless*: communication over wireless link
 - » *mobility*: handling the mobile user who changes point of attachment to network



- Introduction
- Wireless
 - Wireless Links characteristics – CDMA
 - IEEE 802.11 wireless LANs (“wi-fi”)
 - Cellular Internet Access architecture and standards (e.g., GSM)
- Mobility
 - Principles addressing and routing to mobile users
 - Mobile IP
 - Handling mobility in cellular networks
 - Mobility and higher-layer protocols
- Summary

Icons / Metaphors



Information



Common Realization



Knowledge/Competency Pattern



Governance



Alignment



Solution Approach

7

Agenda



1 Session Overview

2 Wireless and Mobile Networks

3 Summary and Conclusion

8

Session Outline

1 Introduction

Wireless

- 2 Wireless links, characteristics
 - » CDMA
- 3 IEEE 802.11 wireless LANs (“wi-fi”)
- 4 Cellular Internet Access
 - » architecture
 - » standards (e.g., GSM)

Mobility

- 5 Principles: addressing and routing to mobile users
- 6 Mobile IP
- 7 Handling mobility in cellular networks
- 8 Mobility and higher-layer protocols

9 Summary

9

Elements of a wireless network

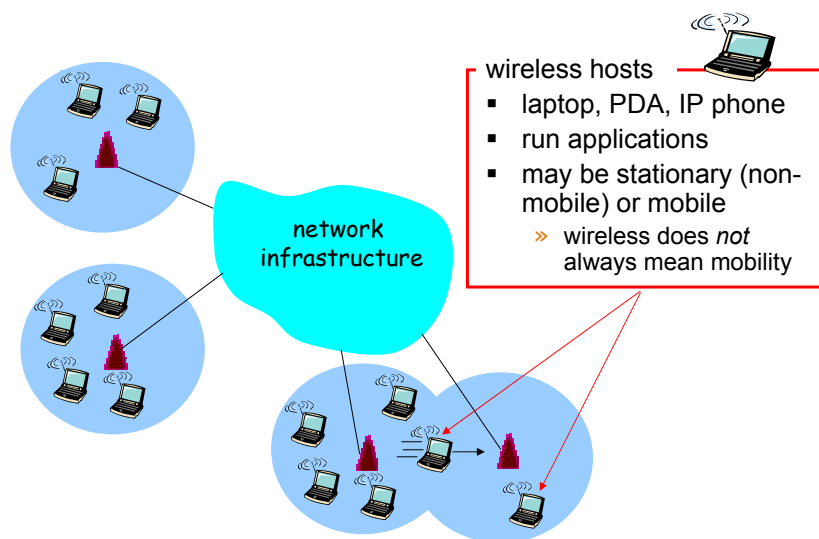

10

Elements of a wireless network

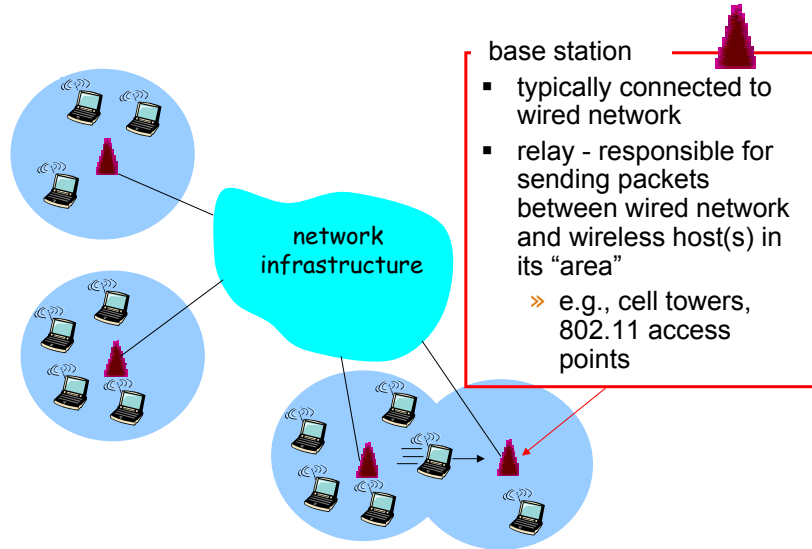

11

Elements of a wireless network

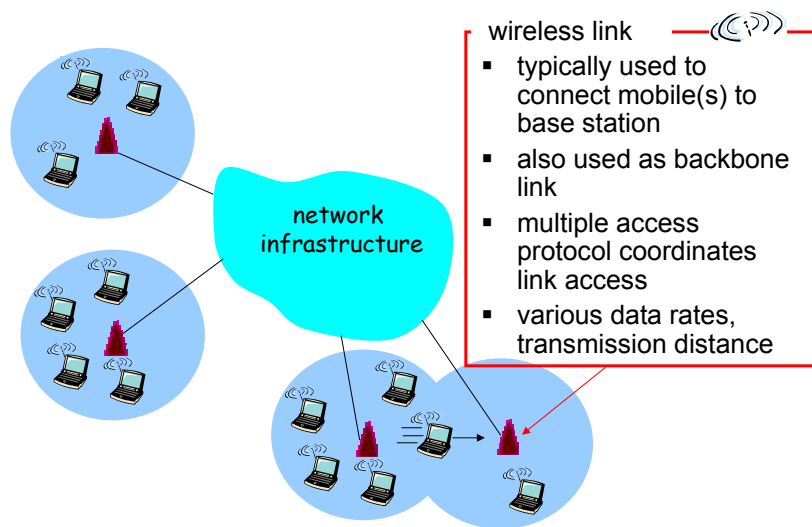

12

Characteristics of selected wireless link standards

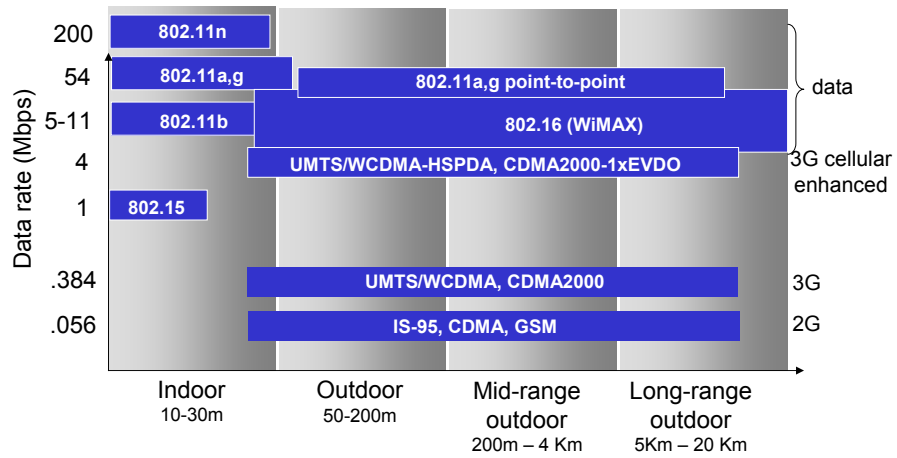

13

Elements of a wireless network

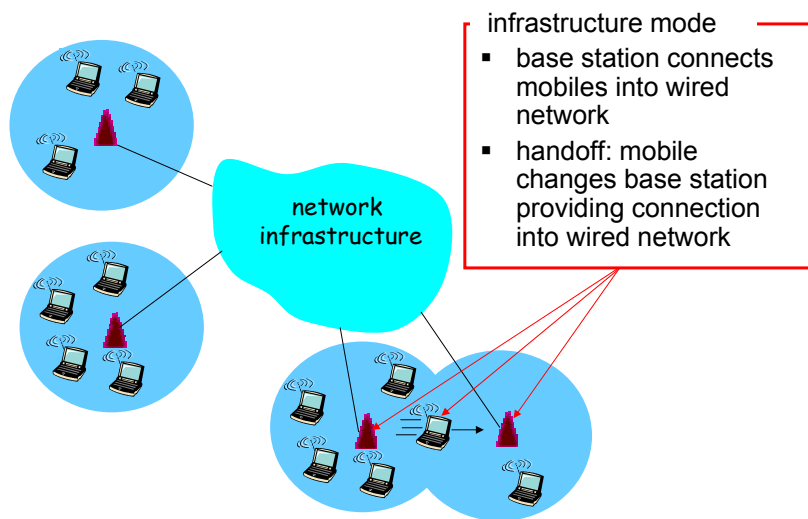

14

Elements of a wireless network

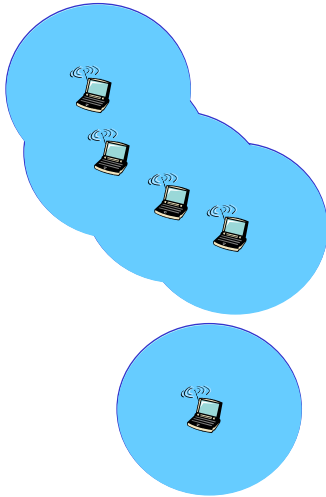

ad hoc mode

- no base stations
- nodes can only transmit to other nodes within link coverage
- nodes organize themselves into a network: route among themselves

15

Wireless network taxonomy

	single hop	multiple hops
infrastructure (e.g., APs)	host connects to base station (WiFi, WiMAX, cellular) which connects to larger Internet	host may have to relay through several wireless nodes to connect to larger Internet: <i>mesh net</i>
no infrastructure	no base station, no connection to larger Internet (Bluetooth, ad hoc nets)	no base station, no connection to larger Internet. May have to relay to reach other a given wireless node MANET, VANET

16

Wireless Link Characteristics (1)

Differences from wired link

- » **decreased signal strength:** radio signal attenuates as it propagates through matter (path loss)
- » **interference from other sources:** standardized wireless network frequencies (e.g., 2.4 GHz) shared by other devices (e.g., phone); devices (motors) interfere as well
- » **multipath propagation:** radio signal reflects off objects ground, arriving at destination at slightly different times

.... make communication across (even a point to point) wireless link much more “difficult”

17

Wireless Link Characteristics (2)

- SNR: signal-to-noise ratio
 - » larger SNR – easier to extract signal from noise (a “good thing”)
- **SNR versus BER tradeoffs**
 - » *given physical layer:* increase power → increase SNR → decrease BER
 - » *given SNR:* choose physical layer that meets BER requirement, giving highest throughput
 - SNR may change with mobility: dynamically adapt physical layer (modulation technique, rate)

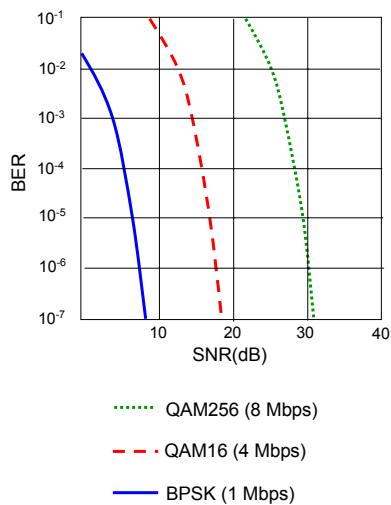

18

Wireless network characteristics

Multiple wireless senders and receivers create additional problems (beyond multiple access):

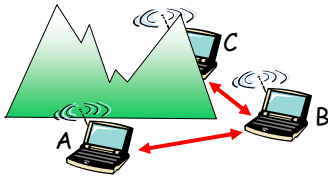

Hidden terminal problem

- B, A hear each other
- B, C hear each other
- A, C can not hear each other

means A, C unaware of their interference at B

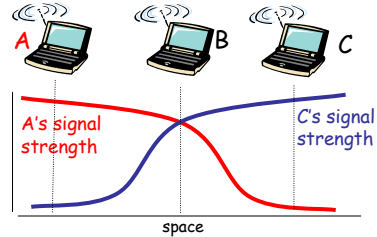

Signal attenuation:

- B, A hear each other
- B, C hear each other
- A, C can not hear each other interfering at B

19

Code Division Multiple Access (CDMA)

- used in several wireless broadcast channels (cellular, satellite, etc) standards
- unique “code” assigned to each user; i.e., code set partitioning
- all users share same frequency, but each user has own “chipping” sequence (i.e., code) to encode data
- **encoded signal** = (original data) X (chipping sequence)
- **decoding**: inner-product of encoded signal and chipping sequence
- allows multiple users to “coexist” and transmit simultaneously with minimal interference (if codes are “orthogonal”)

20

CDMA Encode/Decode

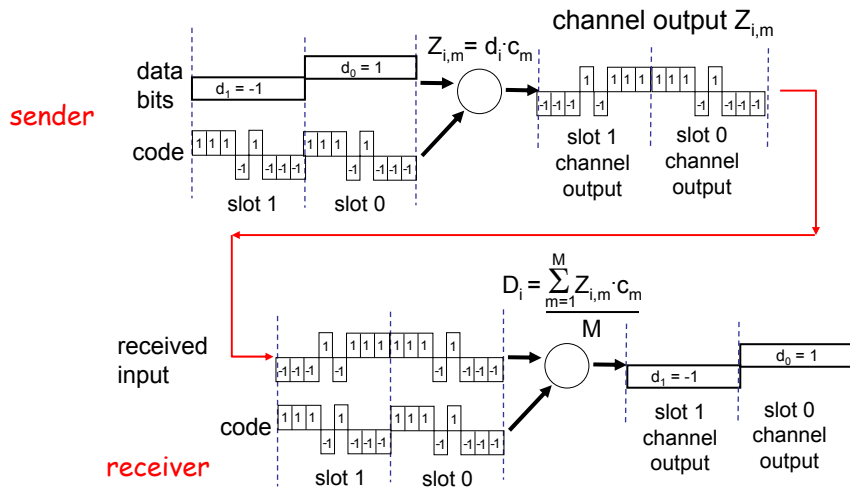

CDMA: two-sender interference

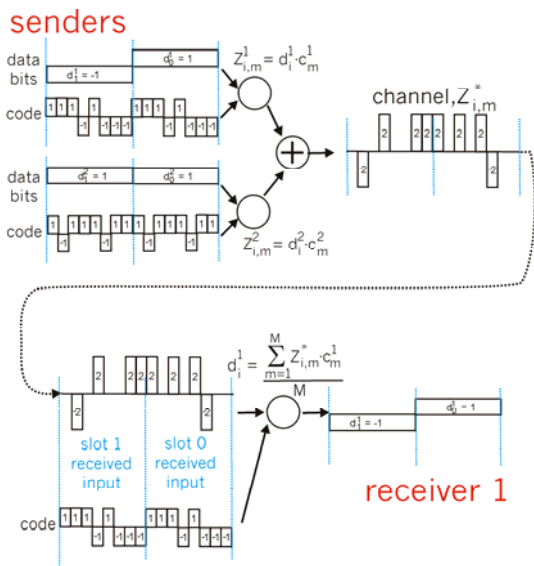

Session Outline

1 Introduction

Wireless

- 2 Wireless links, characteristics
 - » CDMA
- 3 IEEE 802.11 wireless LANs (“wi-fi”)
- 4 cellular Internet access
 - » architecture
 - » standards (e.g., GSM)

Mobility

- 5 Principles: addressing and routing to mobile users
- 6 Mobile IP
- 7 Handling mobility in cellular networks
- 8 Mobility and higher-layer protocols

9 Summary

23

IEEE 802.11 Wireless LAN

- **802.11b**
 - » 2.4-5 GHz unlicensed spectrum
 - » up to 11 Mbps
 - » direct sequence spread spectrum (DSSS) in physical layer
 - all hosts use same chipping code
 - **802.11a**
 - » 5-6 GHz range
 - » up to 54 Mbps
 - **802.11g**
 - » 2.4-5 GHz range
 - » up to 54 Mbps
 - **802.11n**: multiple antennae
 - » 2.4-5 GHz range
 - » up to 200 Mbps
-
- all use CSMA/CA for multiple access
 - all have base-station and ad-hoc network versions

24

802.11 LAN architecture

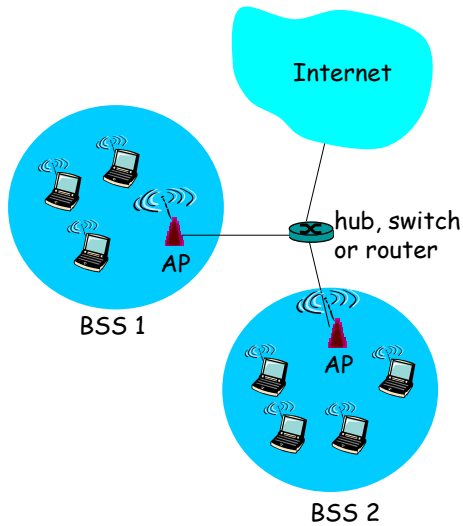

- wireless host communicates with base station
 - › base station = access point (AP)
- Basic Service Set (BSS) (aka “cell”) in infrastructure mode contains:
 - › wireless hosts
 - › access point (AP): base station
 - › ad hoc mode: hosts only

25

802.11: Channels, association

- 802.11b: 2.4GHz-2.485GHz spectrum divided into 11 channels at different frequencies
 - › AP admin chooses frequency for AP
 - › interference possible: channel can be same as that chosen by neighboring AP!
- host: must **associate** with an AP
 - › scans channels, listening for *beacon frames* containing AP’s name (SSID) and MAC address
 - › selects AP to associate with
 - › may perform authentication [Chapter 8]
 - › will typically run DHCP to get IP address in AP’s subnet

26

802.11: passive/active scanning

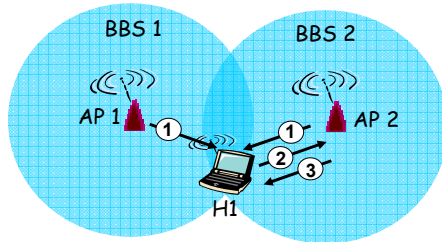

Passive Scanning:

- (1) beacon frames sent from APs
- (2) association Request frame sent: H1 to selected AP
- (3) association Response frame sent: H1 to selected AP

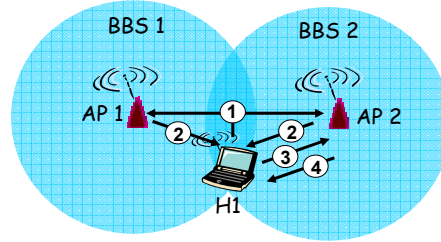

Active Scanning:

- (1) Probe Request frame broadcast from H1
- (2) Probes response frame sent from APs
- (3) Association Request frame sent: H1 to selected AP
- (4) Association Response frame sent: H1 to selected AP

27

IEEE 802.11: multiple access

- avoid collisions: 2+ nodes transmitting at same time
- 802.11: CSMA - sense before transmitting
 - » don't collide with ongoing transmission by other node
- 802.11: *no* collision detection!
 - » difficult to receive (sense collisions) when transmitting due to weak received signals (fading)
 - » can't sense all collisions in any case: hidden terminal, fading
 - » goal: **avoid collisions**: CSMA/C(ollision)A(avoidance)

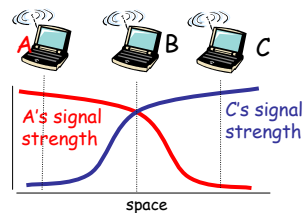
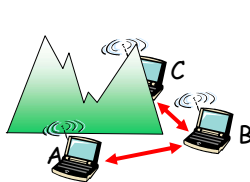

28

IEEE 802.11 MAC Protocol: CSMA/CA

802.11 sender

- 1 if sense channel idle for **DIFS** then
transmit entire frame (no CD)
- 2 if sense channel busy then
start random backoff time
timer counts down while channel idle
transmit when timer expires
if no ACK, increase random backoff interval,
repeat 2

802.11 receiver

- if frame received OK
return ACK after **SIFS** (ACK needed due to
hidden terminal problem)

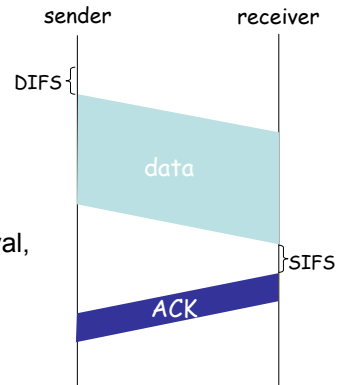

29

Avoiding collisions (more)

- idea:** allow sender to “reserve” channel rather than random access of data frames: avoid collisions of long data frames
- sender first transmits *small* request-to-send (RTS) packets to BS using CSMA
 - » RTSs may still collide with each other (but they're short)
 - BS broadcasts clear-to-send CTS in response to RTS
 - CTS heard by all nodes
 - » sender transmits data frame
 - » other stations defer transmissions

avoid data frame collisions completely
using small reservation packets!

30

Collision Avoidance: RTS-CTS exchange

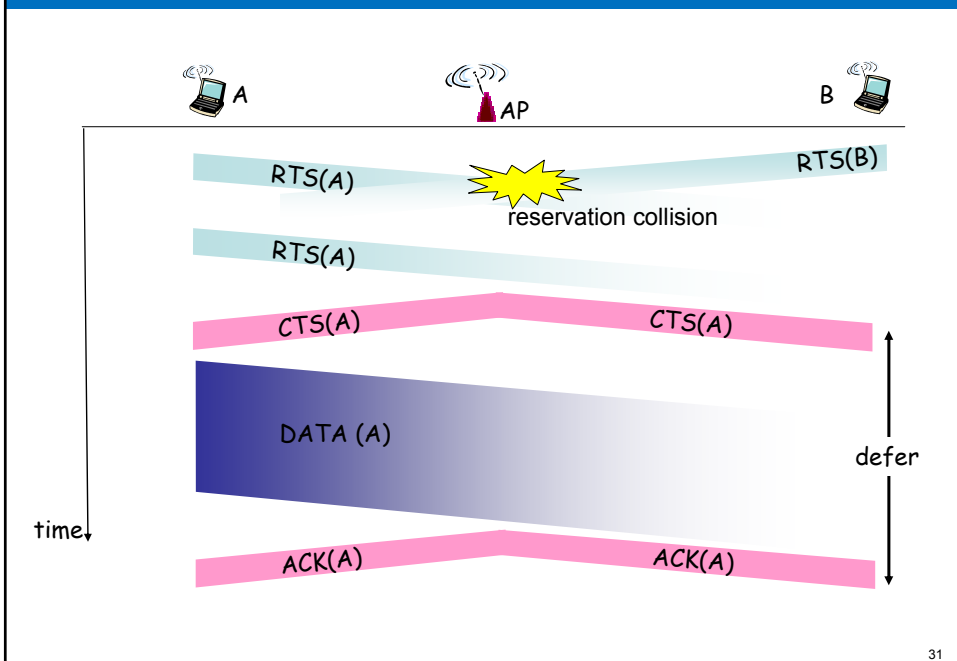

802.11 frame: addressing

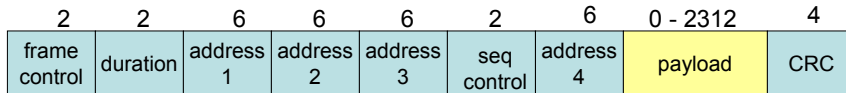

Address 1: MAC address of wireless host or AP to receive this frame

Address 2: MAC address of wireless host or AP transmitting this frame

Address 3: MAC address of router interface to which AP is attached

Address 4: used only in ad hoc mode

802.11 frame: addressing

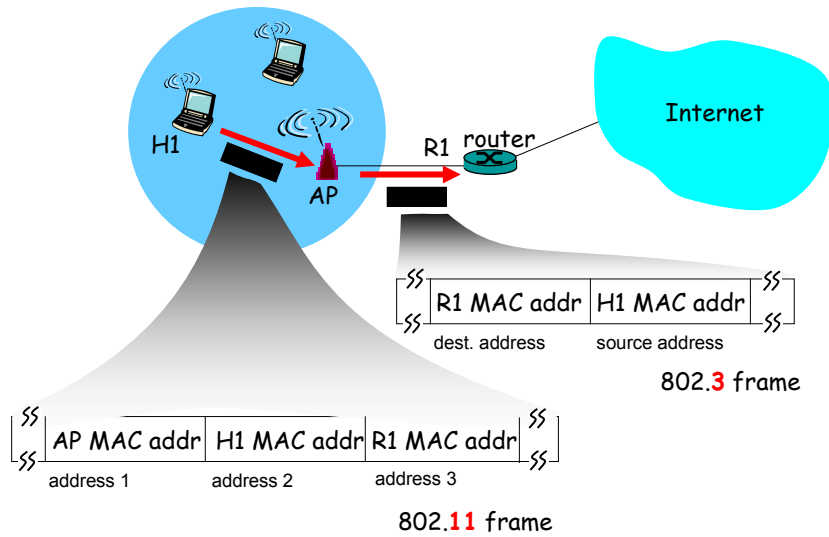

33

802.11 frame: more

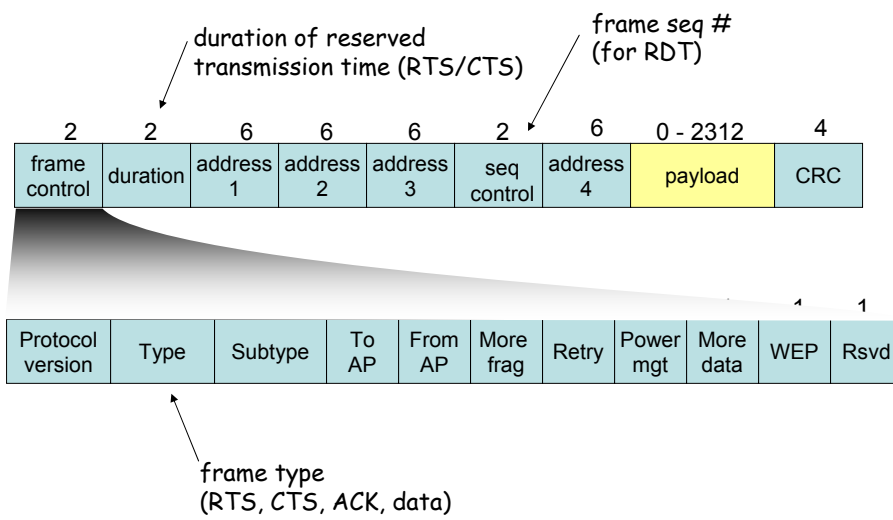

34

802.11: mobility within same subnet

- H1 remains in same IP subnet: IP address can remain same
- switch: which AP is associated with H1?
 - » self-learning (Ch. 5): switch will see frame from H1 and “remember” which switch port can be used to reach H1

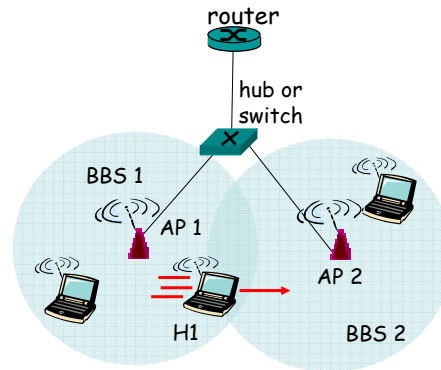

35

802.11: advanced capabilities

Rate Adaptation

- base station, mobile dynamically change transmission rate (physical layer modulation technique) as mobile moves, SNR varies
- Legend:
- QAM256 (8 Mbps)
 - QAM16 (4 Mbps)
 - BPSK (1 Mbps)
 - operating point

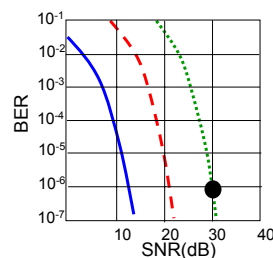

1. SNR decreases, BER increase as node moves away from base station
2. When BER becomes too high, switch to lower transmission rate but with lower BER

36

802.11: advanced capabilities

Power Management

- node-to-AP: “I am going to sleep until next beacon frame”
 - » AP knows not to transmit frames to this node
 - » node wakes up before next beacon frame
- beacon frame: contains list of mobiles with AP-to-mobile frames waiting to be sent
 - » node will stay awake if AP-to-mobile frames to be sent; otherwise sleep again until next beacon frame

37

802.15: personal area network

- less than 10 m diameter
- replacement for cables (mouse, keyboard, headphones)
- ad hoc: no infrastructure
- master/slaves:
 - » slaves request permission to send (to master)
 - » master grants requests
- 802.15: evolved from Bluetooth specification
 - » 2.4-2.5 GHz radio band
 - » up to 721 kbps

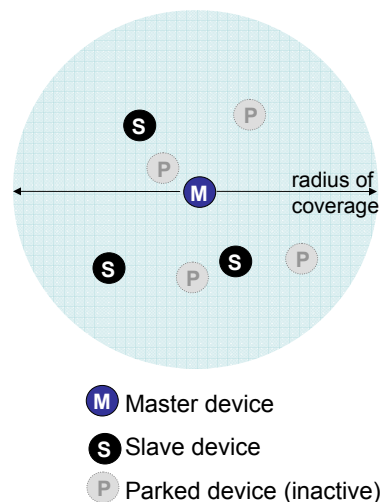

38

802.16: WiMAX

- like 802.11 & cellular: base station model
 - » transmissions to/from base station by hosts with omnidirectional antenna
 - » base station-to-base station backhaul with point-to-point antenna
- unlike 802.11:
 - » range ~ 6 miles (“city rather than coffee shop”)
 - » ~14 Mbps

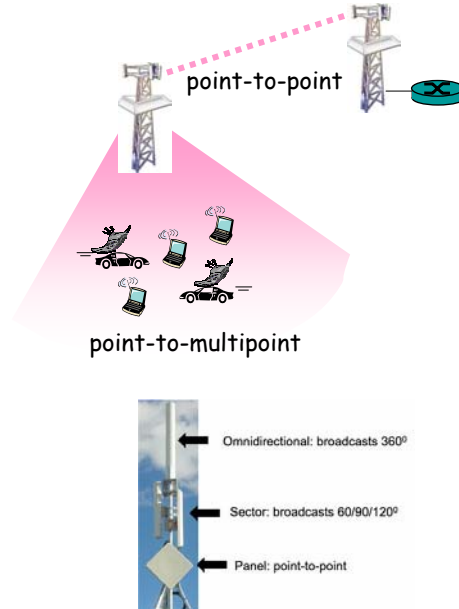

39

802.16: WiMAX: downlink, uplink scheduling

- transmission frame
 - » down-link subframe: base station to node
 - » uplink subframe: node to base station

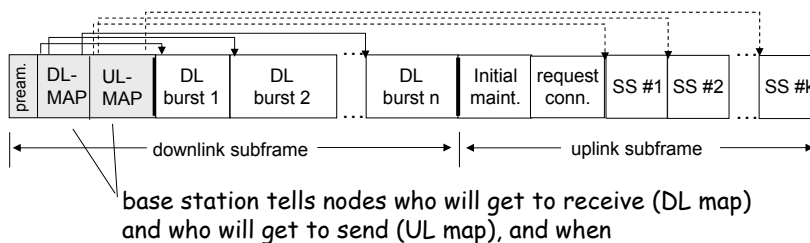

- WiMAX standard provide mechanism for scheduling, but not scheduling algorithm

40

Session Outline

1 Introduction

Wireless

- 2 Wireless links, characteristics
 - » CDMA
- 3 IEEE 802.11 wireless LANs (“wi-fi”)
- 4 Cellular Internet Access
 - » architecture
 - » standards (e.g., GSM)

Mobility

- 5 Principles: addressing and routing to mobile users
- 6 Mobile IP
- 7 Handling mobility in cellular networks
- 8 Mobility and higher-layer protocols

9 Summary

41

Components of cellular network architecture

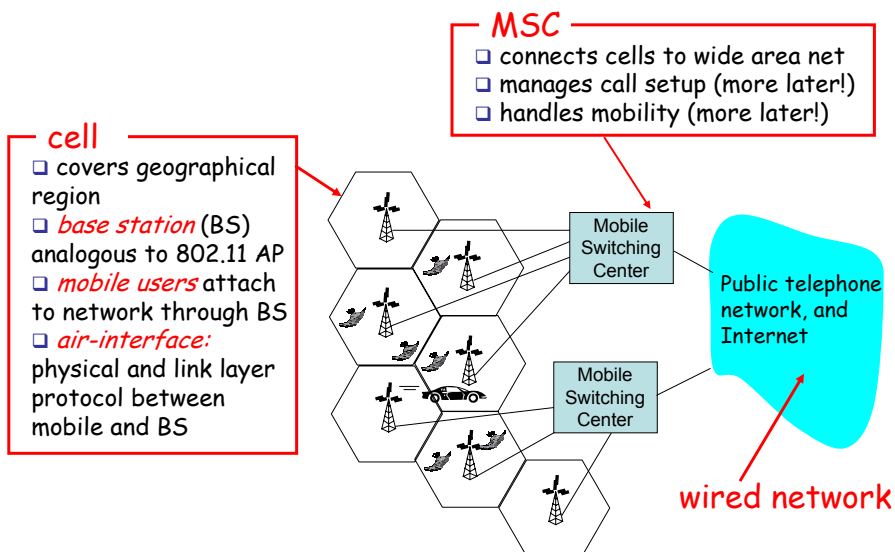

42

Cellular networks: the first hop

Two techniques for sharing mobile-to-BS radio spectrum

- **combined FDMA/TDMA:** divide spectrum in frequency channels, divide each channel into time slots
- **CDMA:** code division multiple access

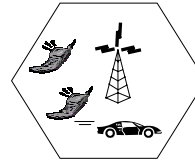

time slots

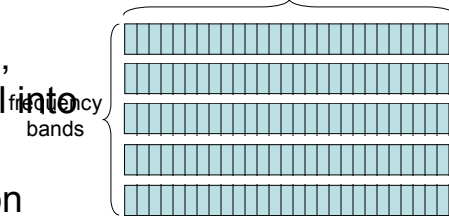

43

Cellular standards: brief survey

2G systems: voice channels

- IS-136 TDMA: combined FDMA/TDMA (north america)
- GSM (global system for mobile communications): combined FDMA/TDMA
 - » most widely deployed
- IS-95 CDMA: code division multiple access

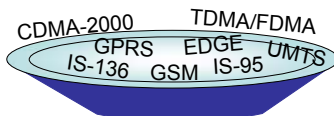

Don't drown in a bowl of alphabet soup: use this for reference only

44

2.5 G systems: voice and data channels

- for those who can't wait for 3G service: 2G extensions
- general packet radio service (GPRS)
 - » evolved from GSM
 - » data sent on multiple channels (if available)
- enhanced data rates for global evolution (EDGE)
 - » also evolved from GSM, using enhanced modulation
 - » data rates up to 384K
- CDMA-2000 (phase 1)
 - » data rates up to 144K
 - » evolved from IS-95

3G systems: voice/data

- Universal Mobile Telecommunications Service (UMTS)
 - » data service: High Speed Uplink/Downlink packet Access (HSDPA/HSUPA): 3 Mbps
- CDMA-2000: CDMA in TDMA slots
 - » data service: 1xEvolution Data Optimized (1xEVDO) up to 14 Mbps

..... more (and more interesting) cellular topics due to mobility (stay tuned for details)

2G (voice) network architecture

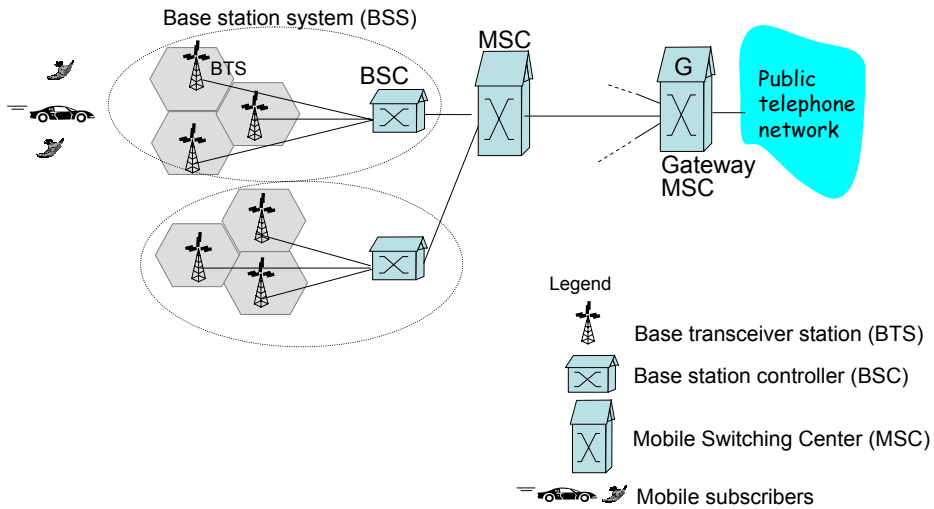

2.5G (voice+data) network architecture

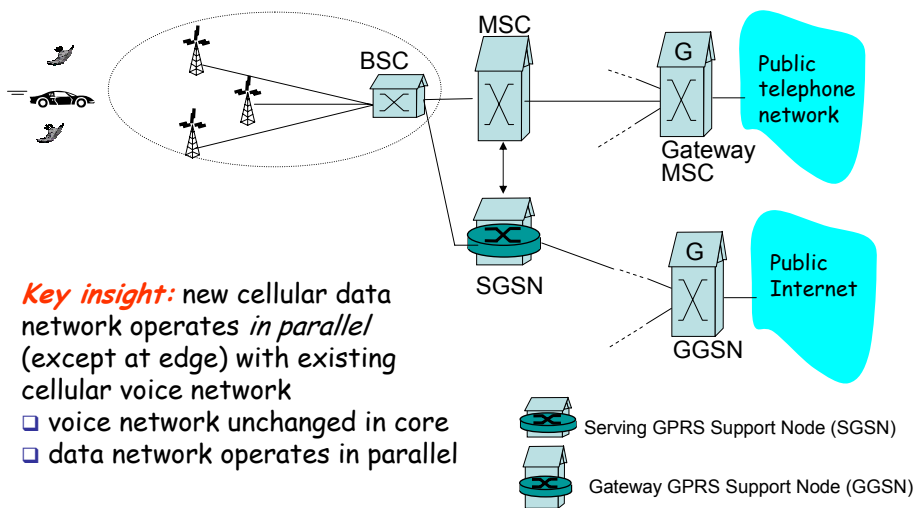

Session Outline

1 Introduction

Wireless

- 2 Wireless links, characteristics
 - » CDMA
- 3 IEEE 802.11 wireless LANs (“wi-fi”)
- 4 Cellular Internet Access
 - » architecture
 - » standards (e.g., GSM)

Mobility

- 5 Principles: addressing and routing to mobile users
- 6 Mobile IP
- 7 Handling mobility in cellular networks
- 8 Mobility and higher-layer protocols

9 Summary

49

What is mobility?

- spectrum of mobility, from the *network* perspective:

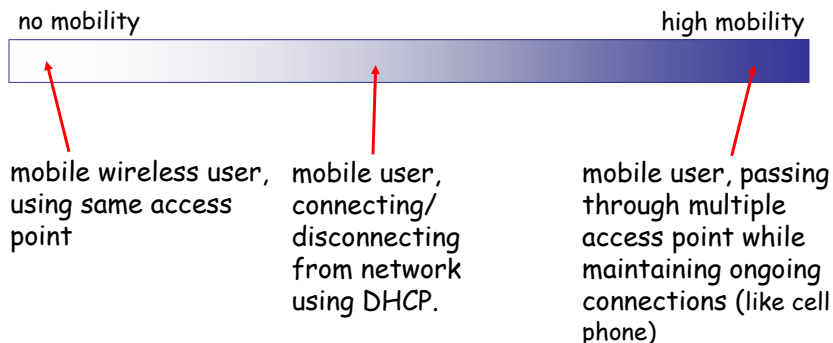

50

Mobility: Vocabulary

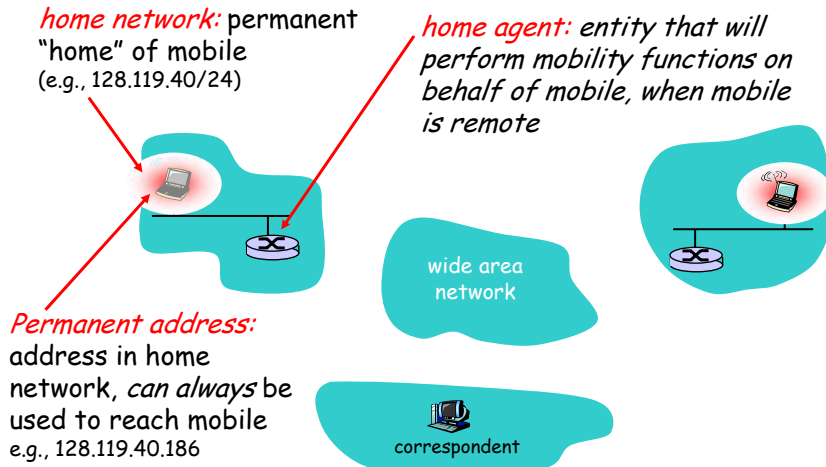

51

Mobility: more vocabulary

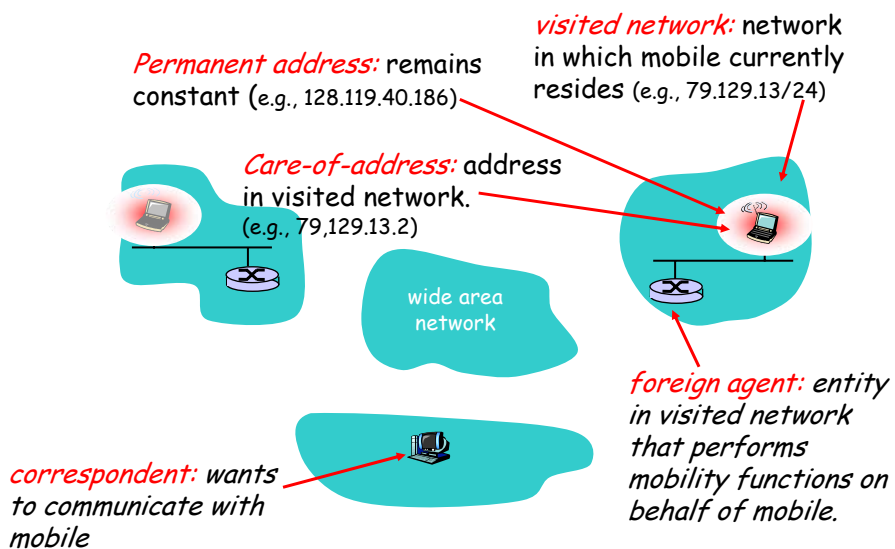

52

How do you contact a mobile friend:

Consider friend frequently changing addresses, how do you find her?

- search all phone books?
- call her parents?
- expect her to let you know where he/she is?



53

Mobility: approaches

- **Let routing handle it:** routers advertise permanent address of mobile-nodes-in-residence via usual routing table exchange.
 - » routing tables indicate where each mobile located
 - » no changes to end-systems
- **Let end-systems handle it:**
 - » **indirect routing:** communication from correspondent to mobile goes through home agent, then forwarded to remote
 - » **direct routing:** correspondent gets foreign address of mobile, sends directly to mobile

54

Mobility: approaches

- *Let routing handle it:* routers advertise permanent address of mobile-nodes-in-residence via routing table exchange.
 - » routing tables grow to millions of mobiles where each mobile located
 - » no changes to end-systems
- *let end-systems handle it:*
 - » *indirect routing:* communication from correspondent to mobile goes through home agent, then forwarded to remote
 - » *direct routing:* correspondent gets foreign address of mobile, sends directly to mobile

55

Mobility: registration

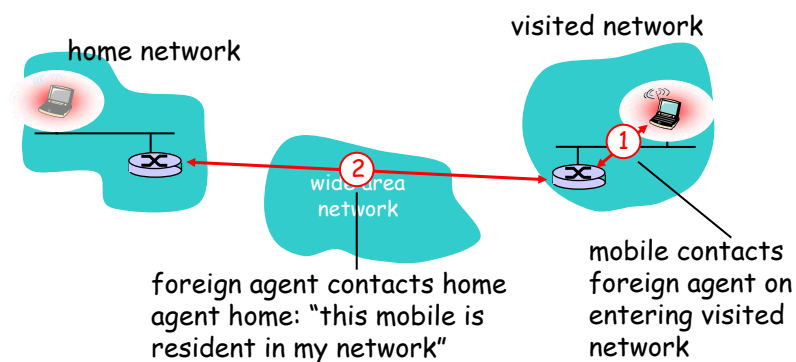

End result:

- Foreign agent knows about mobile
- Home agent knows location of mobile

56

Mobility via Indirect Routing

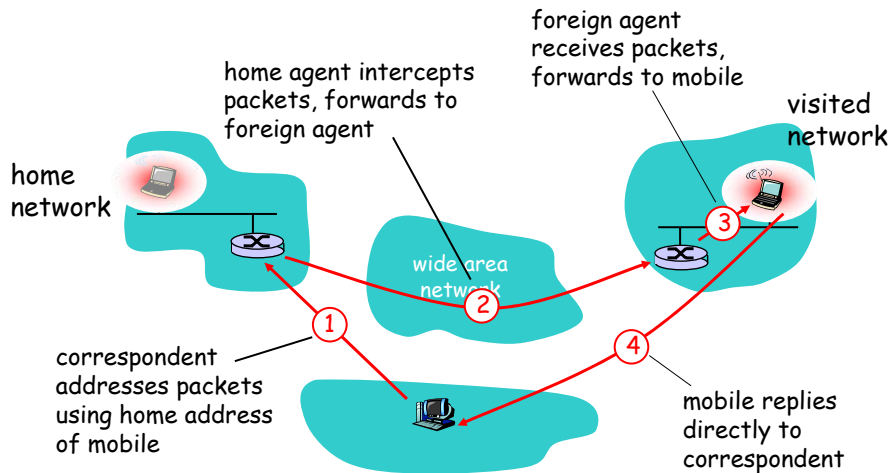

57

Indirect Routing: comments

- Mobile uses two addresses:
 - » **permanent address**: used by correspondent (hence mobile location is *transparent* to correspondent)
 - » **care-of-address**: used by home agent to forward datagrams to mobile
- foreign agent functions may be done by mobile itself
- **triangle routing**: correspondent-home-network-mobile
 - » inefficient when correspondent, mobile are in same network

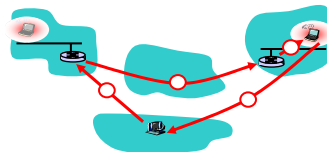

58

Indirect Routing: moving between networks

- suppose mobile user moves to another network
 - » registers with new foreign agent
 - » new foreign agent registers with home agent
 - » home agent update care-of-address for mobile
 - » packets continue to be forwarded to mobile (but with new care-of-address)
- mobility, changing foreign networks transparent: *on going connections can be maintained!*

59

Mobility via Direct Routing

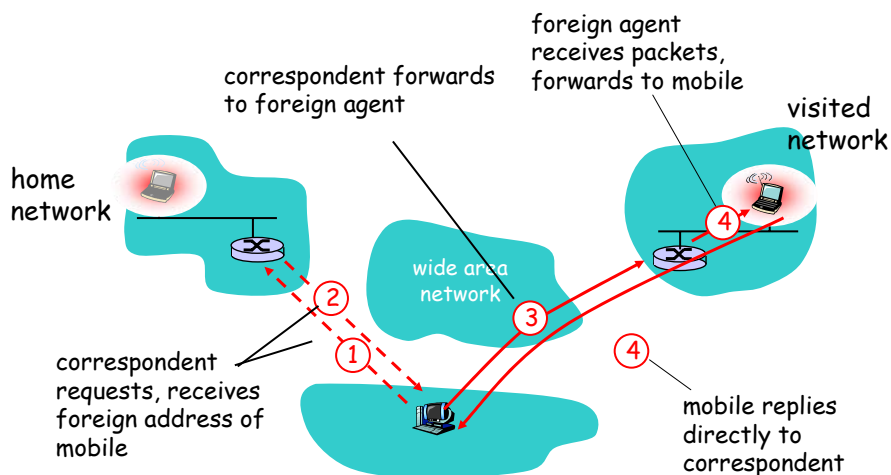

60

Mobility via Direct Routing: comments

- overcome triangle routing problem
- **non-transparent to correspondent:** correspondent must get care-of-address from home agent
 - » what if mobile changes visited network?

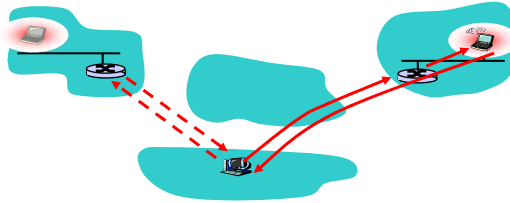

61

Accommodating mobility with direct routing

- anchor foreign agent: FA in first visited network
- data always routed first to anchor FA
- when mobile moves: new FA arranges to have data forwarded from old FA (chaining)

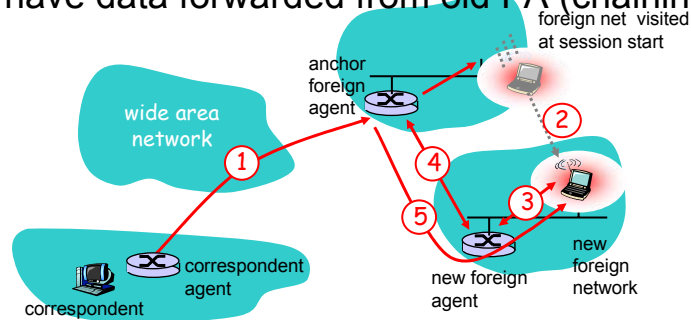

62

Session Outline

1 Introduction

Wireless

- 2 Wireless links, characteristics
 - » CDMA
- 3 IEEE 802.11 wireless LANs (“wi-fi”)
- 4 Cellular Internet Access
 - » architecture
 - » standards (e.g., GSM)

Mobility

- 5 Principles: addressing and routing to mobile users
- 6 Mobile IP
- 7 Handling mobility in cellular networks
- 8 Mobility and higher-layer protocols

9 Summary

63

Mobile IP

- RFC 3344
- has many features we’ve seen:
 - » home agents, foreign agents, foreign-agent registration, care-of-addresses, encapsulation (packet-within-a-packet)
- three components to standard:
 - » indirect routing of datagrams
 - » agent discovery
 - » registration with home agent

64

Mobile IP: indirect routing

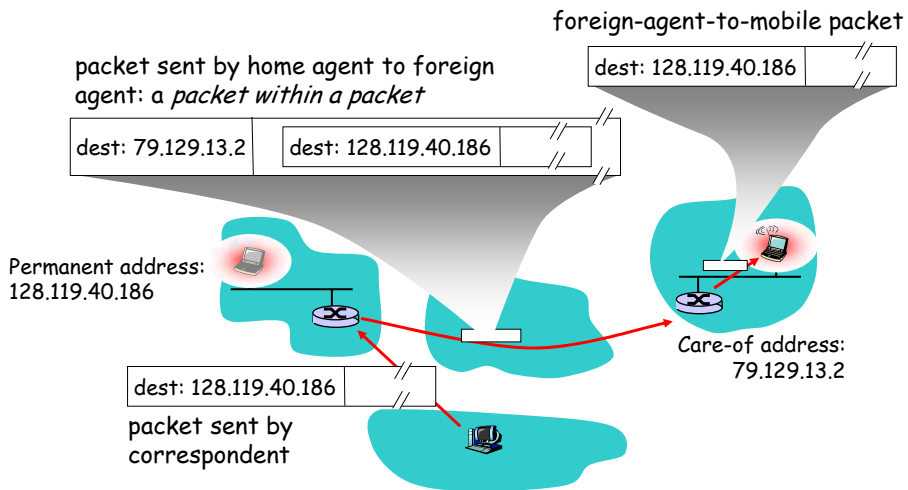

65

Mobile IP: agent discovery

- **agent advertisement:** foreign/home agents advertise service by broadcasting ICMP messages (type = 9)

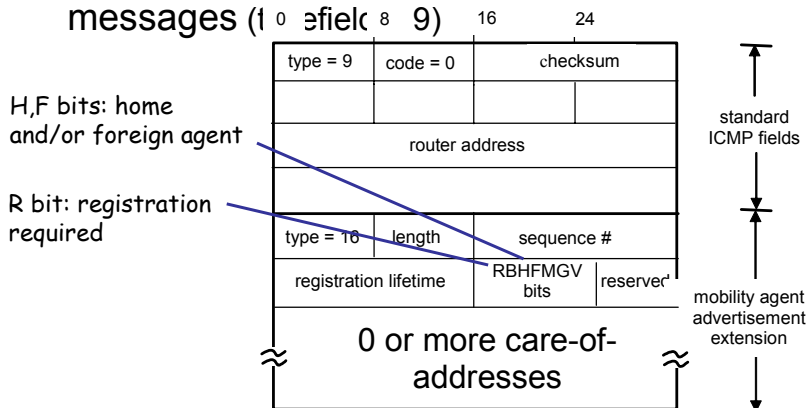

66

Mobile IP: registration example

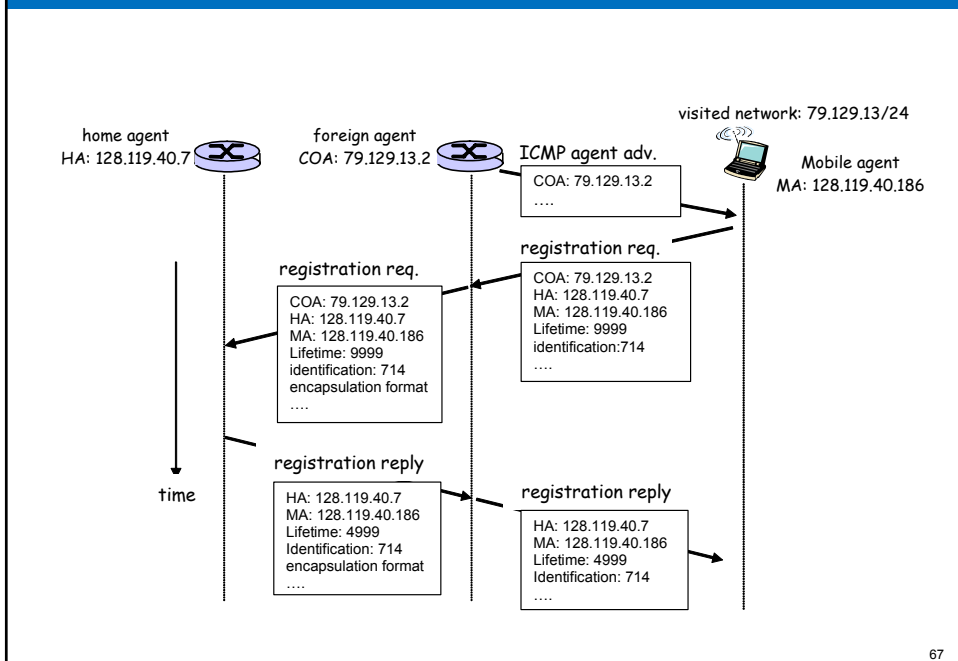

67

Components of cellular network architecture

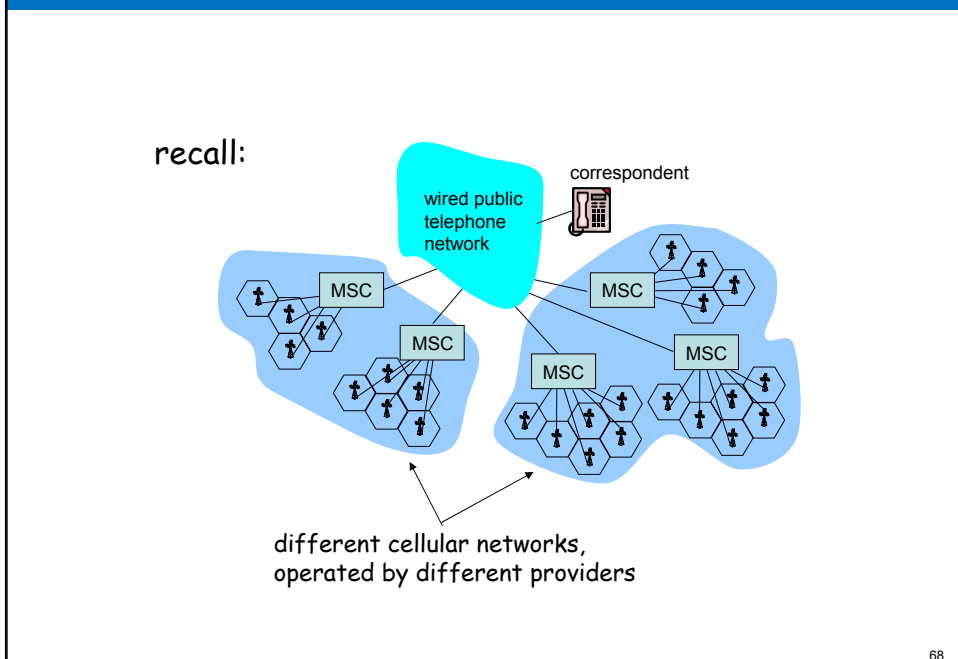

68

Handling mobility in cellular networks

- **home network:** network of cellular provider you subscribe to (e.g., Sprint PCS, Verizon)
 - » **home location register (HLR):** database in home network containing permanent cell phone #, profile information (services, preferences, billing), information about current location (could be in another network)
- **visited network:** network in which mobile currently resides
 - » **visitor location register (VLR):** database with entry for each user currently in network
 - » could be home network

69

GSM: indirect routing to mobile

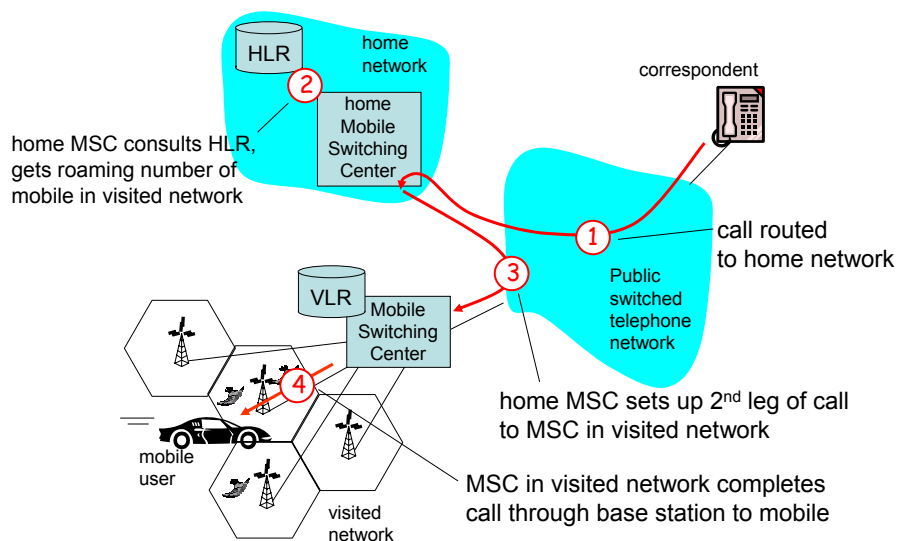

70

GSM: handoff with common MSC

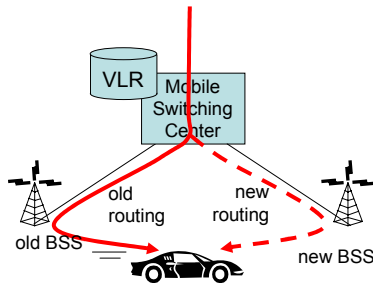

- Handoff goal: route call via new base station (without interruption)
- reasons for handoff:
 - › stronger signal to/from new BSS (continuing connectivity, less battery drain)
 - › load balance: free up channel in current BSS
 - › GSM doesn't mandate why to perform handoff (policy), only how (mechanism)
- handoff initiated by old BSS

71

GSM: handoff with common MSC

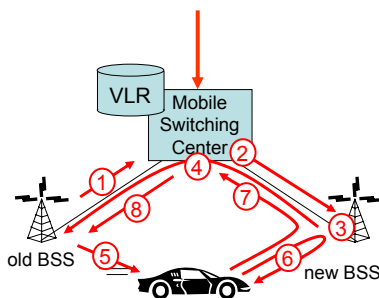

1. old BSS informs MSC of impending handoff, provides list of 1+ new BSSs
2. MSC sets up path (allocates resources) to new BSS
3. new BSS allocates radio channel for use by mobile
4. new BSS signals MSC, old BSS: ready
5. old BSS tells mobile: perform handoff to new BSS
6. mobile, new BSS signal to activate new channel
7. mobile signals via new BSS to MSC: handoff complete. MSC reroutes call
8. MSC-old-BSS resources released

72

GSM: handoff between MSCs

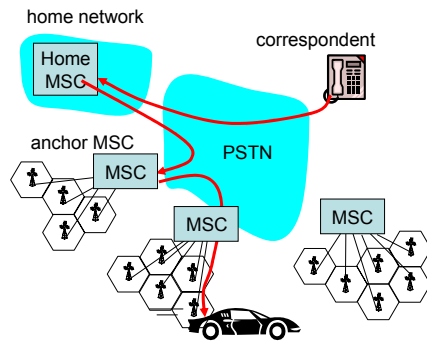

- **anchor MSC:** first MSC visited during cal
 - » call remains routed through anchor MSC
- new MSCs add on to end of MSC chain as mobile moves to new MSC
- IS-41 allows optional path minimization step to shorten multi-MSC chain

73

GSM: handoff between MSCs

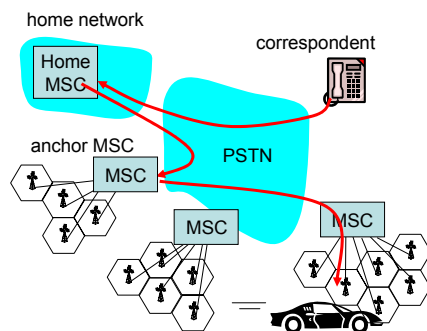

- **anchor MSC:** first MSC visited during cal
 - » call remains routed through anchor MSC
- new MSCs add on to end of MSC chain as mobile moves to new MSC
- IS-41 allows optional path minimization step to shorten multi-MSC chain

74

Mobility: GSM versus Mobile IP

GSM element	Comment on GSM element	Mobile IP element
Home system	Network to which mobile user's permanent phone number belongs	Home network
Gateway Mobile Switching Center, or "home MSC". Home Location Register (HLR)	Home MSC: point of contact to obtain routable address of mobile user. HLR: database in home system containing permanent phone number, profile information, current location of mobile user, subscription information	Home agent
Visited System	Network other than home system where mobile user is currently residing	Visited network
Visited Mobile services Switching Center. Visitor Location Record (VLR)	Visited MSC: responsible for setting up calls to/from mobile nodes in cells associated with MSC. VLR: temporary database entry in visited system, containing subscription information for each visiting mobile user	Foreign agent
Mobile Station Roaming Number (MSRN), or "roaming number"	Routable address for telephone call segment between home MSC and visited MSC, visible to neither the mobile nor the correspondent.	Care-of-address

75

Wireless, mobility: impact on higher layer protocols

- logically, impact *should* be minimal ...
 - » best effort service model remains unchanged
 - » TCP and UDP can (and do) run over wireless, mobile
- ... but performance-wise:
 - » packet loss/delay due to bit-errors (discarded packets, delays for link-layer retransmissions), and handoff
 - » TCP interprets loss as congestion, will decrease congestion window un-necessarily
 - » delay impairments for real-time traffic
 - » limited bandwidth of wireless links

76

Agenda

- 1 Session Overview
 - 2 Data Link Control
 - 3 Summary and Conclusion
- 

77

Summary

Wireless

- wireless links:
 - » capacity, distance
 - » channel impairments
 - » CDMA
- IEEE 802.11 (“wi-fi”)
 - » CSMA/CA reflects wireless channel characteristics
- cellular access
 - » architecture
 - » standards (e.g., GSM, CDMA-2000, UMTS)

Mobility

- principles: addressing, routing to mobile users
 - » home, visited networks
 - » direct, indirect routing
 - » care-of-addresses
- case studies
 - » mobile IP
 - » mobility in GSM
- impact on higher-layer protocols

78

Assignments & Readings

- Readings



- › Chapter 6

- Assignment #4

- › Will be assigned at the completion of Session 7

Next Session: Reliable Data Transfer