

SNO-WAY®

SNOW & ICE CONTROL EQUIPMENT

WIRING DIAGRAM AND INSTALLATION INSTRUCTIONS

**FOR 99101148
ADAPTER KIT**

Sno-Way®, Down Pressure® and EIS® are registered trademarks of Sno-Way International, Inc.
ProControl™, MegaBlade™, V-Wing™, E-Z Switch™, Revolution™, MaxAdjust™, SpeedLock™, and QuickJack™
are trademarks of Sno-Way International, Inc.

©2014 Sno-Way® International

97101834D

WIRING DIAGRAM



1. THINK SAFETY, ALWAYS WEAR SAFETY GLASSES WHEN PERFORMING THE OPERATIONS PRESCRIBED IN THESE INSTRUCTIONS
2. READ ALL INSTRUCTIONS CAREFULLY BEFORE ATTEMPTING INSTALLATION



IMPORTANT: Use a dielectric compound on all connections to prevent corrosion.

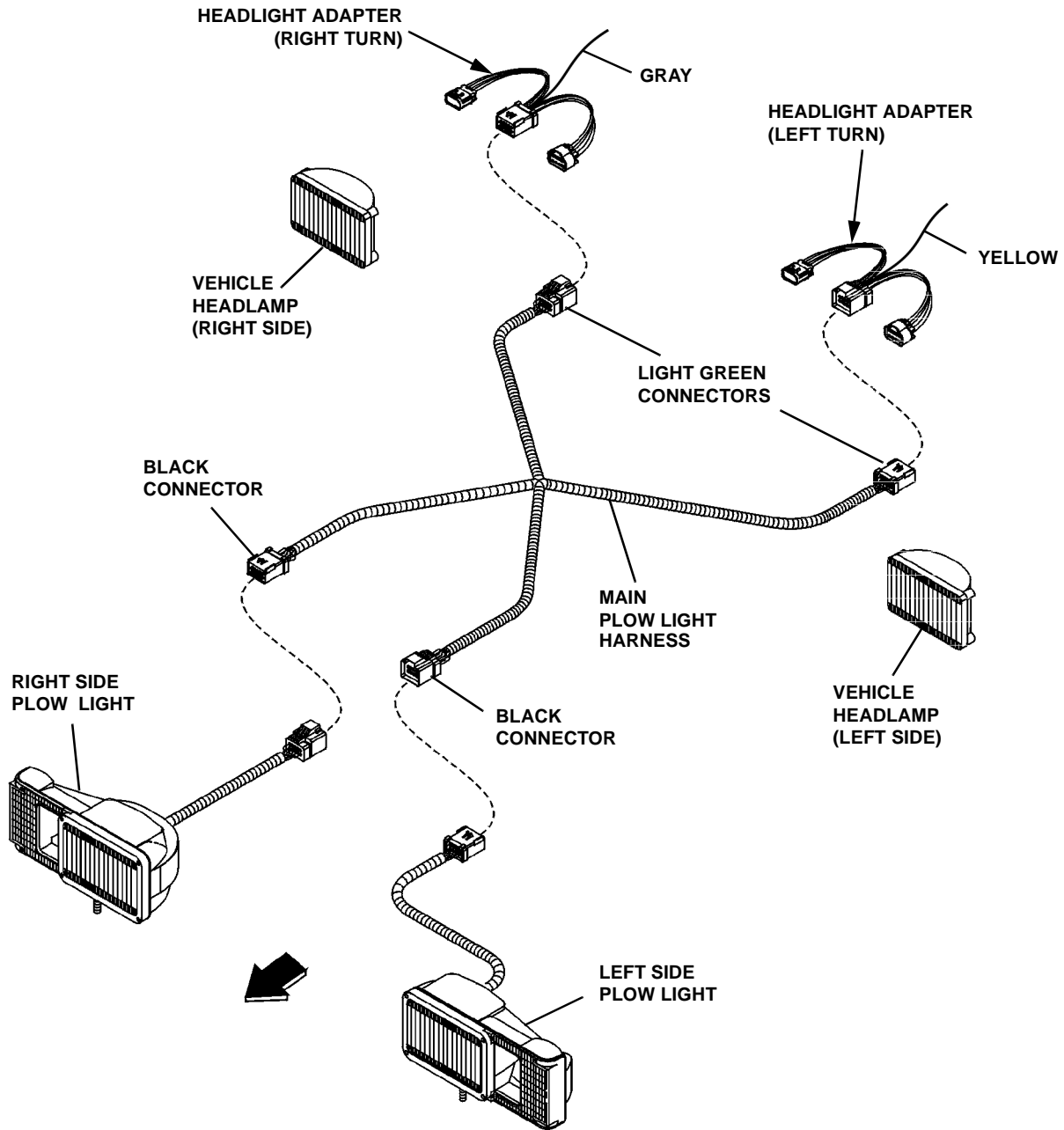

Figure 1

Headlight Adapter Schematic - Female (96115112) (Driver's Side)

FEMALE CONNECTOR LAYOUT

CAVITY POSITION	WIRE COLOR / PLUG
A	WHITE
B	LT GREEN
C	LT BLUE
D	PLUG
E	BROWN
F	ORANGE
G	BLACK WITH WHITE STRIPE
H	RED WITH BLACK STRIPE

MALE CONNECTOR LAYOUT

CAVITY POSITION	WIRE COLOR / PLUG
A	WHITE
B	GREEN
C	BLUE
D	PLUG
E	BROWN
F	YELLOW
G	BLACK WITH WHITE STRIPE
H	RED WITH BLACK STRIPE

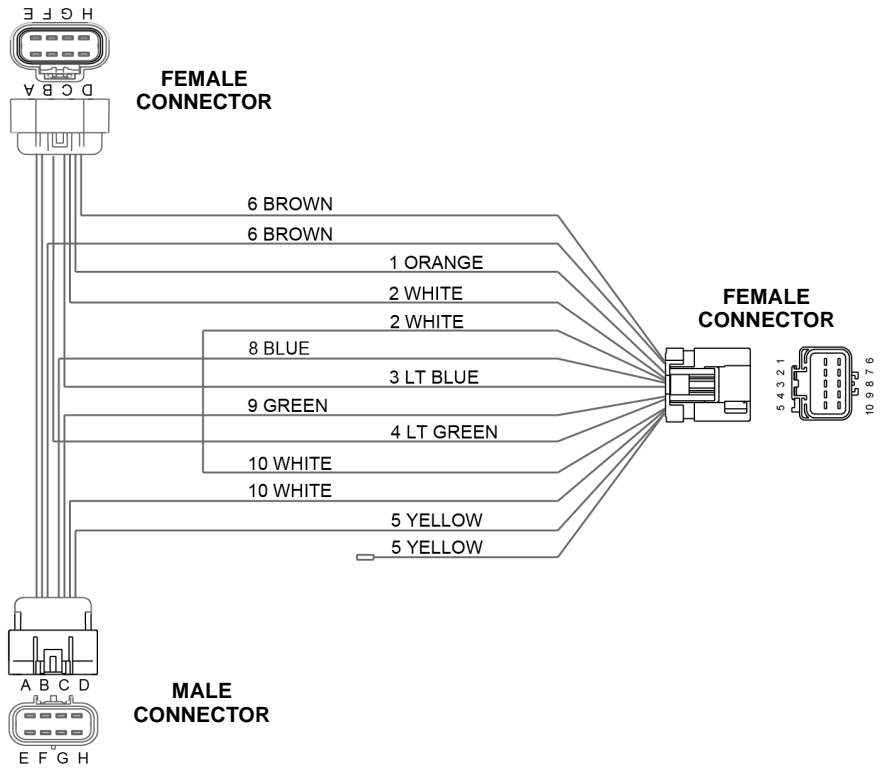

Figure 2

Headlight Adapter Schematic - Male (96115113) (Passenger's Side)

FEMALE CONNECTOR LAYOUT

CAVITY POSITION	WIRE COLOR / PLUG
A	WHITE
B	LT GREEN
C	LT BLUE
D	PLUG
E	BROWN
F	VIOLET
G	BLACK WITH WHITE STRIPE
H	RED WITH BLACK STRIPE

MALE CONNECTOR LAYOUT

CAVITY POSITION	WIRE COLOR / PLUG
A	WHITE
B	GREEN
C	BLUE
D	PLUG
E	BROWN
F	GRAY
G	BLACK WITH WHITE STRIPE
H	RED WITH BLACK STRIPE

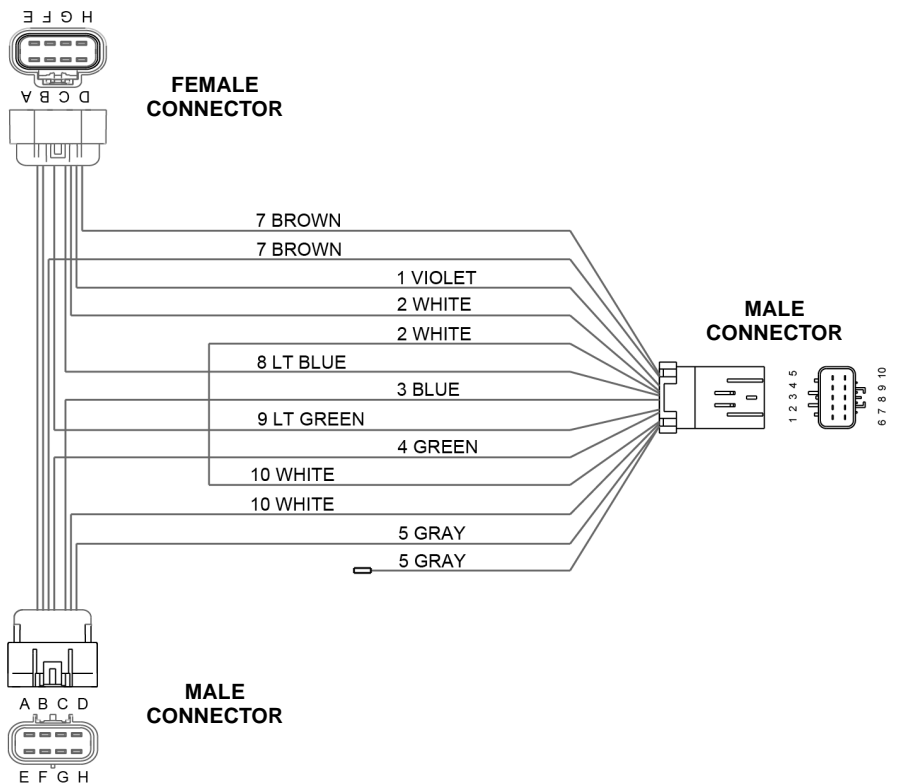

Figure 3

ADAPTER KIT INSTALLATION (Refer to Wiring Diagrams)

CAUTION

- **THINK SAFETY, ALWAYS WEAR SAFETY GLASSES WHEN PERFORMING THE OPERATIONS PRESCRIBED IN THESE INSTRUCTIONS**
- **READ ALL INSTRUCTIONS CAREFULLY BEFORE ATTEMPTING INSTALLATION**

IMPORTANT: Use a dielectric compound on all connections to prevent corrosion.

Prior to Installation:

1. You must first determine what vehicle this adapter is being installed on. In efforts to reduce the number of components carried by our dealer network, we have opted to keep a common 99101148 adapter that is to be modified as necessary based on application.
2. If you are installing on a GMC, you must first remove the loose wire from the 96115112 and 96115113 adapters. If you are installing on a Chevrolet, skip to step 5.
3. Remove the loose yellow wire from adapter by cutting wire just behind the female green plug (See Figure 1).

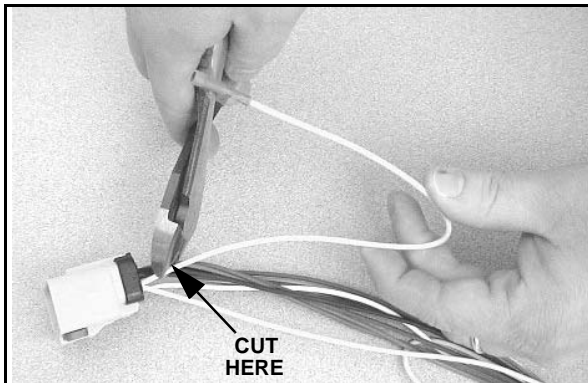

Figure 1

4. Remove the loose gray wire from adapter by cutting wire just behind the male green plug (See Figure 2).

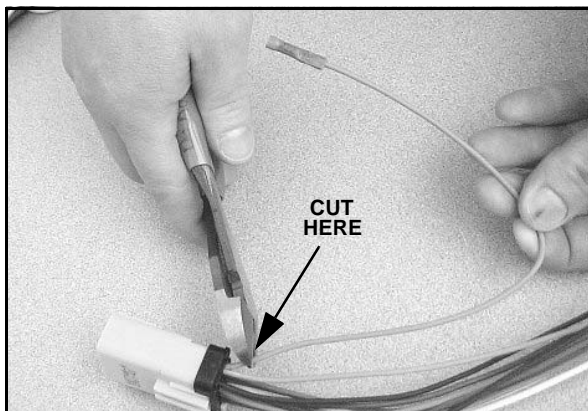

Figure 2

5. Review your headlamp pod (96107893) wiring prior to installing the 99101148 adapter.
6. Locate the driver side plow headlamp housing. Inspect the black male 10 pin connector. If the violet wire is present in pin location 1 it must be removed as part of the remedy to the fast flash condition on the vehicle. It is important that you remove this wire from the connector, looming, and internal plow headlamp pod. Once this is completed, the new headlamp part number for reference is 96111609.
7. Locate the passenger side plow headlamp housing. Inspect the black female 10 pin connector. If the orange wire is present in pin location 5, it must be removed as part of the remedy to the fast flash condition on the vehicle. It is important that you remove this wire from the connector, looming, and internal plow headlamp pod. Once this is completed, the new headlamp part number for reference is 96111628.
8. The new headlamp pod kit part # is 96111608.

NOTE: There is no interchangeability in the adapter components. Driver and passenger harnesses must each be installed on the correct side in order for each to work properly.

Installation - Driver's Side:

1. Remove the headlamp housing.
2. Locate the driver's side adapter and differentiate it from the passenger's side adapter. The driver's side adapter is the one with a yellow wire in it. The passenger's side adapter is the one with a gray wire in the position where the driver's side has a yellow wire.
3. On the main snow plow light harness, locate the light green driver's side connector. Take the driver's side adapter and locate the light green connector compatible with the green connector on the main snow plow light harness. Plug the green adapter connector and the green main harness connector together. If installing on a GMC, skip to step 7.
4. The headlamp housing already has a truck manufacturer's adapter installed on it. Prior to disconnecting any wires from the vehicle's adapter you must prep the vehicle's adapter to receive the snow plow adapter. There are two turn/run bulbs within the headlamp housing—one primary and one secondary. Locate the secondary turn/run bulb—it's the one with four wires attached to it. (The primary bulb has 6 wires running to it.) Within those four wires, locate the turn signal source wire. At a suitable distance from the turn signal socket, cut the turn signal source wire—you need enough wire on each side of the cut to accommodate the attachment of a butt splice.

5. Within the driver's side snow plow adapter, locate the yellow wire with an open ended butt splice crimped onto it. Crimp the open end of the butt splice on to the wire going back to the secondary turn signal bulb that you cut in Step 4.
 6. Leave the wire running to the primary bulb cut in step four hanging loose. If the harness is ever removed the wire can then be spliced back together.
 7. Note again, as in Step 4: The headlamp housing already has a truck manufacturer's adapter installed on it. The wires from the various lights in the lamp housing converge in a large rectangular 8 terminal connection. Locate this connection and pull it apart.
 8. The 8 terminal lamp side and truck side connectors which you just pulled apart each have 8 terminal mates in the snowplow adapter harness. In the snowplow adapter harness locate the connectors compatible with the 8 terminal lamp side and truck side connectors that you just pulled apart in the vehicle harness. Plug the lamp side and truck side connectors within the vehicle harness into the corresponding 8 terminal connectors within the snowplow adapter harness. Driver's Side installation should now be complete.
5. Leave the wire running to the primary bulb cut in step 3 hanging loose. If the harness is ever removed the wire can then be spliced back together.
 6. Note again, as in Step 3: The headlamp housing already has a truck manufacturer's adapter installed on it. The wires from the various lights in the lamp housing converge in a large rectangular 8 terminal connection. Locate this connection and pull it apart.
 7. The 8 terminal lamp side and truck side connectors which you just pulled apart each have 8 terminal mates in the snowplow adapter harness. In the snowplow adapter harness locate the connectors compatible with the 8 terminal lamp side and truck side connectors that you just pulled apart in the vehicle harness. Plug the lamp side and truck side connectors within the vehicle harness into the corresponding 8 terminal connectors within the snowplow adapter harness. Passenger's side installation should now be complete.

IMPORTANT: For 2015 and later models, every time the EIS harness connection is broken, the vehicle's IGNITION AND LIGHTS must be cycled off/on. Protective software in the vehicle's computer prevents the headlamps from working after connecting and disconnecting to the plow lamps. Turning the headlamp switch off/on is not sufficient, to reset the vehicle's computer, the IGNITION AND LIGHTS must be turned off and then back on.

Installation - Passenger's Side:

1. Locate the passenger's side adapter set aside in "Installation - Driver's Side:", Step 2.
2. On the main snow plow light harness, locate the light green passenger's side connector. Take the passenger's side adapter and locate the light green connector compatible with the green connector on the main snow plow light harness. Plug the green adapter connector and the green main harness connector together. If installing on a GMC, skip to step 6.
3. As on the driver's side, the passenger's side headlamp housing already has a truck manufacturer's adapter installed on it. Prior to disconnecting any wires from the vehicle's adapter you must prep the vehicle's adapter to receive the snow plow adapter. There are two turn/run bulbs within the headlamp housing—one primary and one secondary. Locate the secondary turn/run bulb—it's the one with four wires attached to it. (The primary bulb has 6 wires running to it.) Within those four wires, locate the turn signal source wire. At a suitable distance from the turn signal socket, cut the turn signal source wire—you need enough wire on each side of the cut accommodate the attachment of a butt splice.
4. Within the passenger's side snow plow adapter, locate the gray wire with an open ended butt splice crimped onto it. Crimp the open end of the butt splice on to the wire going back to the secondary turn signal bulb that you cut in Step 3.



CAUTION

**Make sure that wire harness is routed away from all moving engine components.
Example; fan, belts etc.
DO NOT attach wire harness to hoses, radiator AC coils, exhaust manifolds, or control cables.**

SNO-WAY® INTERNATIONAL, INC.



Hartford, WI 53027 USA
Website: www.snoway.com
©2014 Sno-Way® International