

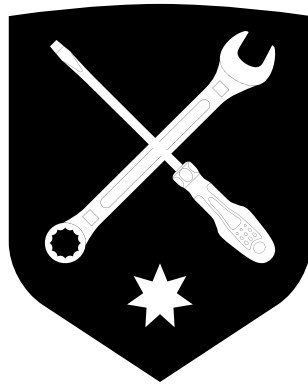

# **WK2 ROOF RACK**

## INSTALL INSTRUCTIONS

**REVISION A**  
14 MARCH 2020



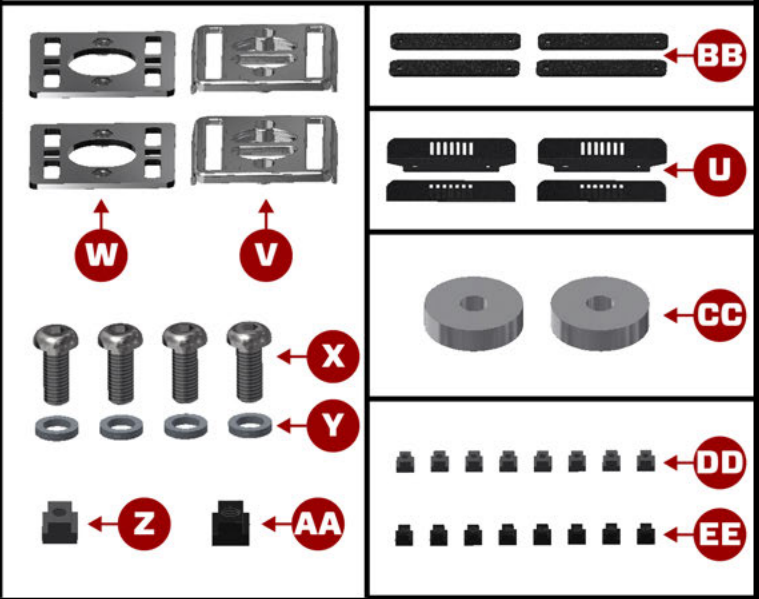
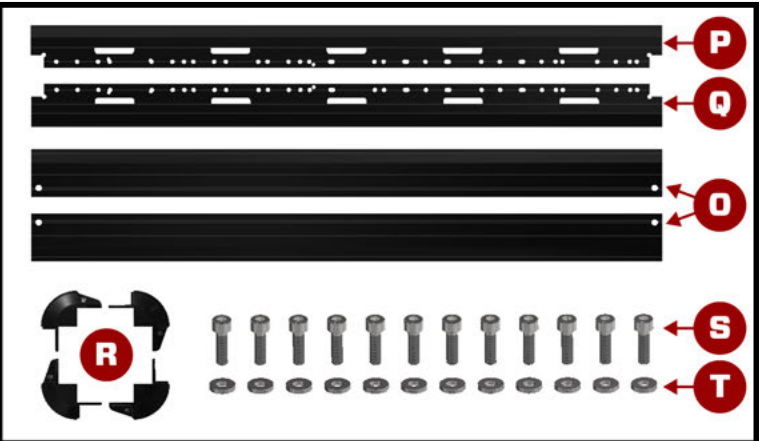
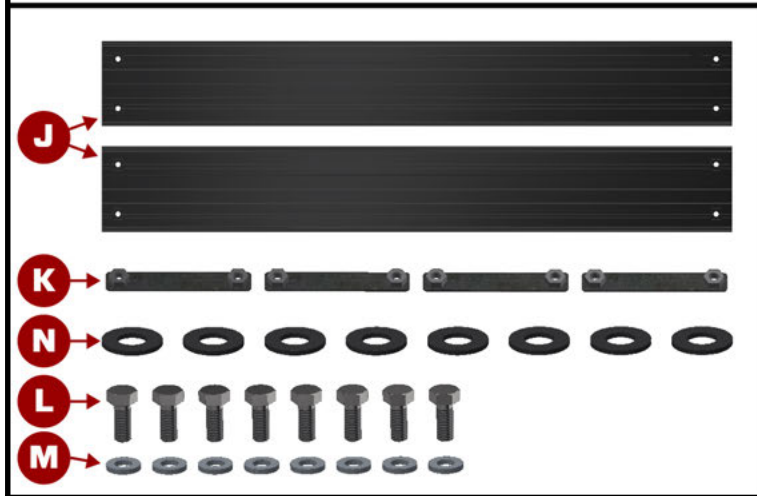
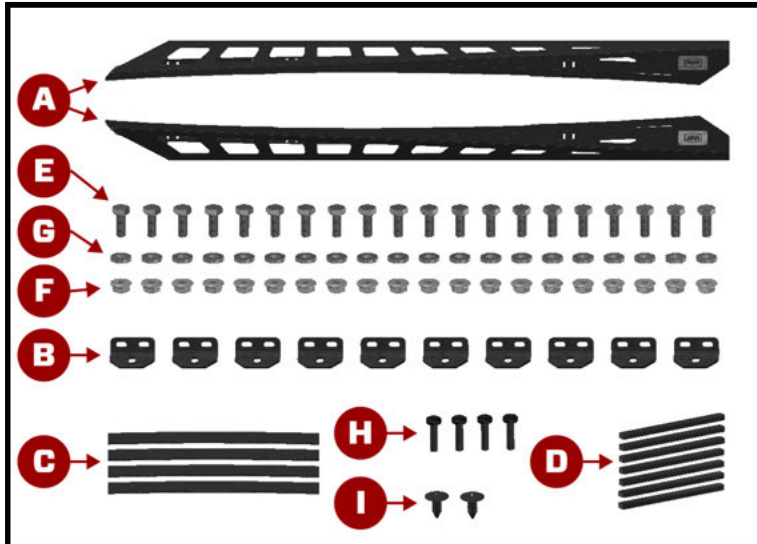

REF	QTY	DESCRIPTION
<b>MOUNTING RAILS</b>		
A	2	Mounting Rail (Left + Right)
B	10	Mounting Rail - Angle Bracket
C	4	EPDM Rubber U-Channel Strip
D	7	Wind Noise Suppressor
E	20	M6 x 16mm Hex Head 8.8 Bolt (Zinc)
F	20	M6 CLB Hex Flange Nut (Zinc)
G	24	M6 Wedge-Lock Extended Washer
H	4	M6 x 25mm TORX T30 Button Head 8.8 Screw (Black Oxide)
I	2	M8 x 20mm Plastic X-Mas Tree Plug (20mm Head)
-	1	4g Anti-Seize Pouch
-	1	Chief Products Shop Rag
<b>2x PLANK KIT — 1146mm</b>		
J	2	Plank
K	4	M8 Fastening Plate
L	8	M8 x 20mm Hex Head 8.8 Bolt (Zinc)
M	8	M8 Wedge-Lock Extended Washer
N	8	M8 Flat Rubber Washer
<b>PLATFORM FRAME KIT</b>		
O	2	Frame Rail (Front + Rear)
P	1	Frame Rail (Left)

REF	QTY	DESCRIPTION
Q	1	Frame Rail (Right)
R	4	Frame Corner
S	16	M6 x 20mm H5 Socket Cap Head 12.9 Screw (Zinc)
T	16	M6 Wedge-Lock Extended Washer
<b>4x PLANK END-CAP KIT — SLOTTED</b>		
U	4	Plank End-Cap (Slotted)
<b>2x TIE-DOWN PLATE KIT</b>		
V	2	Tie-Down (Top)
W	2	Tie-Down (Bottom Plate)
X	4	M8 x 20mm H5 Socket Button Head Screw (SS316)
Y	4	M8 Wedge-Lock Extended Washer
Z	1	M8 T-Nut 10.9 (Black Oxide)
AA	1	M10 T-Nut 10.9 (Black Oxide)
<b>ROOF TOP TENT KIT</b>		
BB	4	Roof Top Tent Bracket
<b>BLACK LOW PROFILE OEM RAILS — ADAPTER KIT</b>		
CC	2	M8 x 8mm Spacer Bush (AL6061)
<b>T-NUT KIT</b>		
DD	5	M8 T-Nut 10.9 (Black Oxide)
EE	5	M10 T-Nut 10.9 (Black Oxide)

**REQUIRED TOOLS**

13mm Socket	Torque Wrench
10mm Socket	Tape Measure
Ratchet & Extension	
10mm Wrench	
T30 Torx (long shaft)	
H5 Hex Key	

**NOTES**

- DO NOT OVER-TIGHTEN FASTENERS.
- LEFT & RIGHT SIDES ARE DEFINED FROM THE DRIVERS POSITION.
- PHOTOS ARE REPRESENTATIVE ONLY. Photos may show prototype parts, may be taken from multiple vehicles, and may be different than your vehicle. Due to global vehicle variances, model year changes and differing model options (engine, options, etc.) it is impossible to provide photos that are 100% accurate for all customers.

## IMPORTANT

- PROPER INSTALLATION IS ESSENTIAL TO THE PERFORMANCE OF THIS PRODUCT.
- ONLY INSTALL THIS PRODUCT ON A 2011-2020 JEEP GRAND CHEROKEE.
- ONLY USE THE PROVIDED HARDWARE FOR INSTALLATION.
- DO NOT MODIFY THE STRUCTURE OF THIS PRODUCT IN ANY WAY.
- CHECK PRODUCT REGULARLY FOR DAMAGE. REPLACE IMMEDIATELY AT FIRST SIGN OF DAMAGE.
- CHECK FASTENER TIGHTNESS REGULARLY AND TIGHTEN IF REQUIRED.
- WK2 ROOF RACK DELIVERS INDEPENDENTLY TESTED LOAD RATINGS OF 150KG (Dynamic) & 600KG (Static). Testing results are certified to comply with Australian Standard (AS 1235-2000) as well as international standards (ISO / PAS 11154 : 2009:2006) and (DIN 75302/02: 1991).
- FOR MAXIMUM SAFETY DO NOT EXCEED MANUFACTURERS ROOF WEIGHT LIMITS. Our load ratings represent the maximum mechanical forces our roof rack system can withstand before failure. Our load ratings do not address vehicle safety during high-speed manoeuvres, or changes to vehicle dynamics caused by a higher centre of gravity.
- FOR MAXIMUM SAFETY, LOADS SHOULD BE EVENLY DISTRIBUTED AND PROPERLY SECURED TO AVOID SHIFTING DURING TRANSPORT. Before using your roof rack, it is important to familiarise yourself with the proper load securing techniques and be constantly safety oriented. Please note, all of our load ratings are based on an evenly distributed load.

**1**

### Remove OEM ROOF RAILS.

1. Remove (4) T30 TORX Screws (inside channel). Retain for Angle Bracket installation (Step 2). Discard any non-captive washers.
2. Slide OEM Rail forward then up to release from front & rear location posts.
3. Do this for both sides (Driver & Passenger)

#### NOTE

A penetrant oil can be used to help release roof fasteners.



#### FASTENERS:

- If WK2 Roof Rack will be used in a corrosive environment, we recommend Anti-Seize on all fasteners that use Wedge-Lock Washers.
- For (8) OEM T30 TORX Screws (without wedge-lock washers) we recommend use of Mid-Strength Loctite (or similar) instead of Anti-Seize.

**2**

### Install ANGLE BRACKETS.

1. Create (2) Screw & Washer Combos, by adding (1) M6 Wedge-Lock Extended Washer [G] to (1) M6 x 25mm TORX T30 Button Head Screw [H].
2. Install (1) Angle Bracket [B] using Screw & Washer Combo onto front nutsert on each side (left & right).
3. Install (8) Angle Brackets [B] using (8) OEM T30 TORX Screws (from Step 1) into the next (4) nutserts (on each side). Leave last nutsert on each side empty.
4. Position Angle Brackets [B] so the upper flange is located inboard. LEAVE ALL BRACKETS LOOSE.



**3**

### Prepare MOUNTING RAILS.

1. Insert (2) M8 x 20mm Plastic X-Mas Tree Plug [I] into M6 nutserts on front face of Mounting Rails [A].



## 4

### Prepare MOUNTING RAILS.

1. Fit (4) EPDM Rubber U-Channel Strips [C] to the lower front & rear outer edges of Mounting Rails [A].
2. Align EPDM Rubber U-Channel Strip [C] ends with front & rear ends of Mounting Rails [A].



## 5

### Install MOUNTING RAILS.

1. Place Mounting Rails [A] on vehicle so angled face is forward, and Angle Brackets [B] (highlighted in grey) are resting against inside face of Mounting Rail [A].
2. Create (20) Bolt & Washer Combos, using M6 x 16mm Hex Head Bolt [E] and (20) M6 Wedge-Lock Extended Washer.
3. Insert Bolt & Washer Combo through outside face of Mounting Rails [A] and Angled Brackets [B]. Place M6 Hex Flange Nut [F] on Bolt and loosely tighten against inside face of Angled Brackets [B].

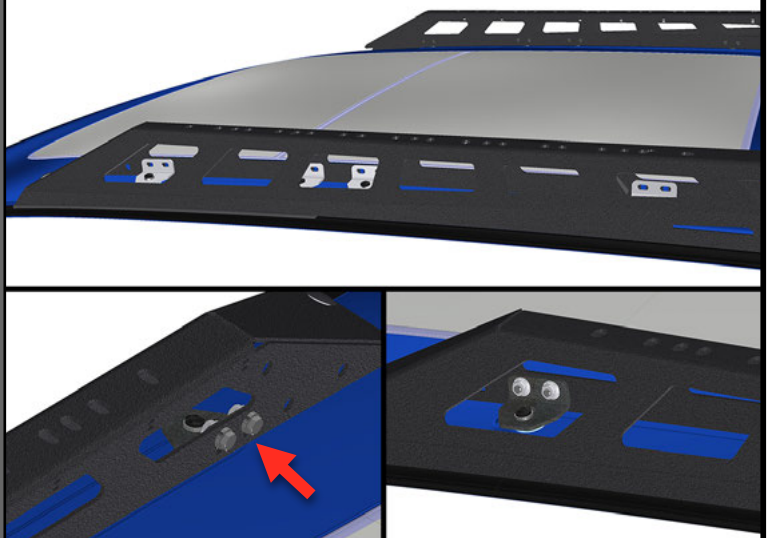

## 6

### Install MOUNTING RAILS.

1. If your vehicle has **Black Low Profile OEM Rails**, you need to install the Adapter KIT now. Place (1) M8 x 8mm Spacer Bush [CC] between last roof nutsert and Mounting Rail [A]. Do this on both sides (left & right).
2. If your vehicle has **Standard OEM Rails**, the Mounting Rails [A] will sit flush against the roof nutsert (no bushing needed).
3. Create (2) Screw & Washer Combos, by adding (1) M6 Wedge-Lock Extended Washer [G] to (1) M6 x 25mm TORX T30 Button Head Screw [H].
4. Insert Bolt & Washer Combo through Mounting Rail [A] and M8 x 8mm Spacer Bush [CC] (if needed) and loosely tighten into roof nutsert.

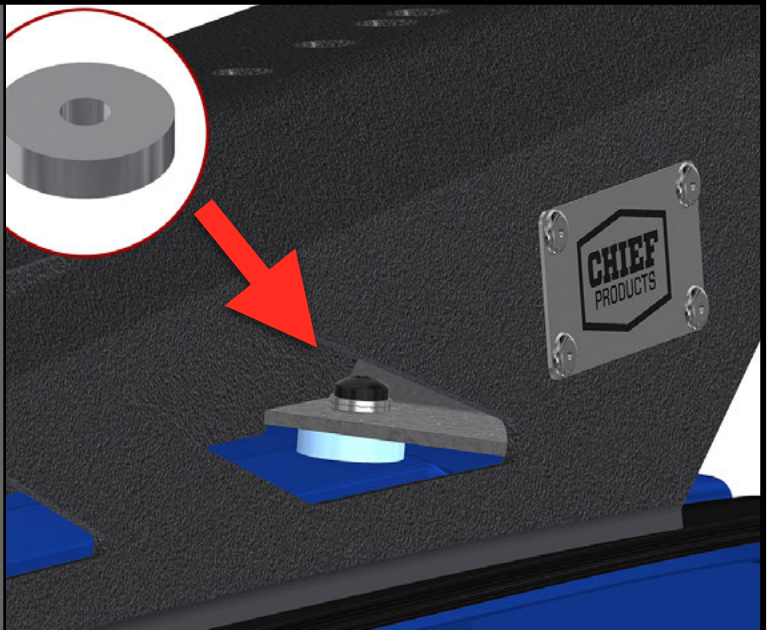

### DAD JOKE

DAD: *\*loudly\** I HATE YOU AND YOUR ENTIRE FAMILY!!  
 SON: *\*rushing into the room\** Who are you talking to?!  
 DAD: *\*calmly\** A mosquito.

# 7

## Install WIND NOISE SUPPRESSORS.

1. Place (1) Plank [J] face down (T-Nut tracks face down).
2. Place (1) Wind Noise Suppressor [D] onto underside of Plank [J] 80mm from left edge. Angle Wind Noise Suppressor [D] so that top edge is aligned with chamfered edge of Plank [J] and lower right corner is aligned with centre line of Plank [J], (left photo).
3. Place (1) Wind Noise Suppressor [D] onto underside of Plank [J] 80mm from right edge. Use same Angle as outlined in Step 2, (right photo).

### NOTE

Place Plank on a towel or blanket to avoid scratches during install. Do not remove white backing tape yet.

LEFT

80mm

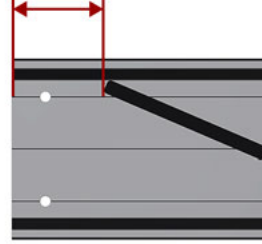

RIGHT

80mm

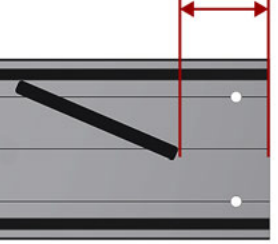

# 8

## Install WIND NOISE SUPPRESSORS.

1. Place (5) Wind Noise Suppressors [D] onto underside of Plank [J] so they are angled the same as the first (2) Wind Noise Suppressors [D] (Step 7) and are evenly spaced between them, (see photo).
2. Remove white backing tape from each Wind Noise Suppressor [D] and secure into place.

### NOTE

Make sure Plank surface is clean for max adhesion. Press and hold each Wind Noise Suppressor for 20 seconds to ensure max adhesion.



## IF YOU HAVE:

- FULL ROOF RACK SYSTEM (*Go To Step 9*).
- SAFARI EDITION, OVERLAND EDITION, ROOF TOP TENT EDITION or BARE BONES EDITION (*Go To Step 16*).
- [MOUNTING RAILS ONLY] (*Go To Step 13*).

# 9

## Prepare PLATFORM FRAME.

1. Locate FRONT-LEFT corner of Platform Frame, (observe hole pattern shown in top photo).
2. Place Platform Frame on Mounting Rails [A]. Align rear edge of Platform Frame with rear edge of Mounting Rails [A], (red arrow bottom photo).

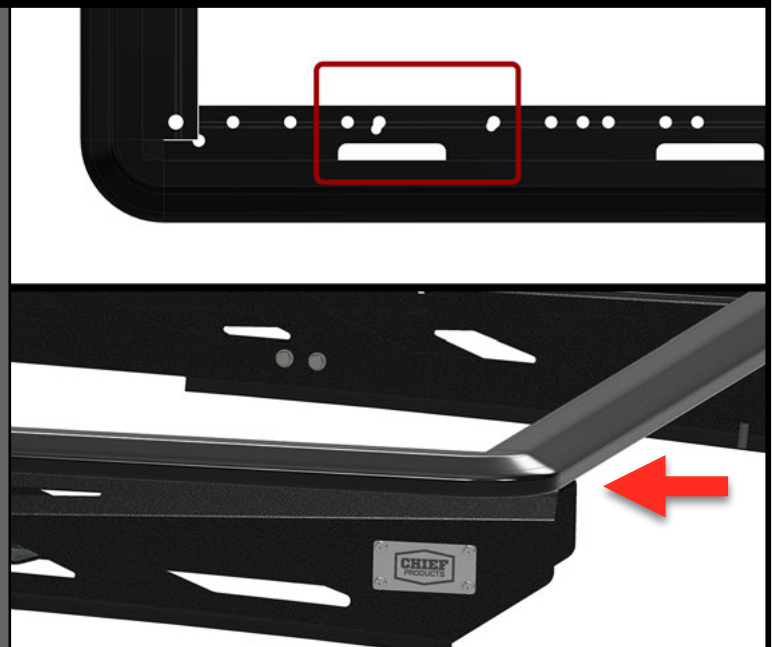



# 10

## Prepare PLATFORM FRAME.

1. Place (2) Frame Rail (Front + Rear) [O], Frame Rail (Left) [P], Frame Rail (Right) [Q] and (4) Frame Corner [R] in position (top photo).
2. Install (1) Frame Corner [R] into each end of each Frame Rail (Front + Rear) [O].
3. Create (16) Screw & Washer Combos, by adding (1) M6 Wedge-Lock Extended Washer [T] to (1) M6 x 20mm H5 Socket Cap Head Screw [S].
4. Insert (2) Bolt & Washer Combo through inner face of Frame Rail (Front + Rear) [O] and loosely tighten into Frame Corner [R]. Do this for each Frame Corner [R].

### NOTE

Place parts on blanket to avoid scratches during installation.

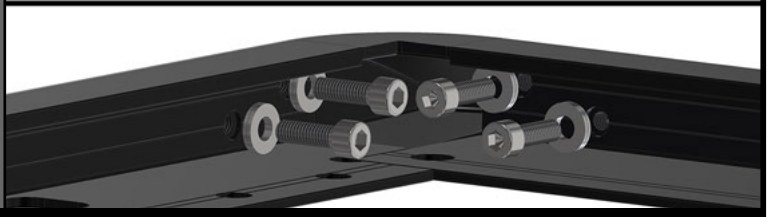
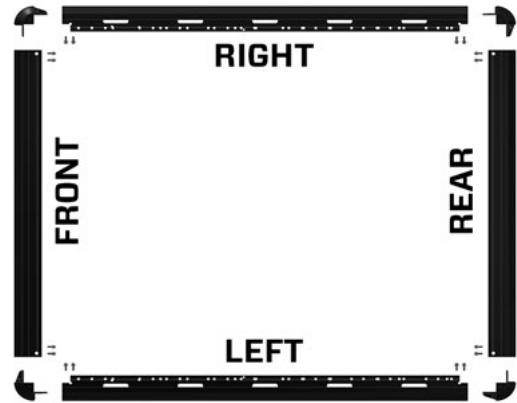

# 11

## Position PLANKS.

1. Place (1) Plank [J] (with Wind Noise Suppressors installed from Step 7) into the front most location in the Platform Frame.
2. Place (1) Plank [J] approximately 594mm (23.39") behind the 1st Plank.

### NOTE

Do not install remaining Planks at this time. This simple (2) Plank configuration provides the best access when tightening the Roof + Mounting Rail fasteners.

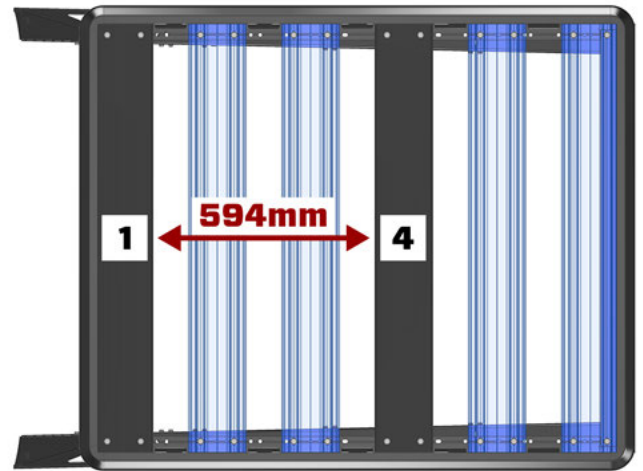

# 12

## Install 2 PLANKS.

1. Create (8) Bolt & Washer Combos, by adding (1) M8 Wedge-Lock Extended Washer [M] to (1) M8 x 20mm Hex Head Bolt [L].
2. Using (2) Bolt & Washer Combos and (1) M8 Fastening Plate [K] secure the end of each Plank [J]. Place M8 Fastening Plate [K] on underside of top face of Mounting Rail [A] (bottom photo - M8 Fastening Plate in red). Insert each Bolt & Washer Combo through Plank [J], through (1) M8 Flat Rubber Washer [N] (red arrows), through Platform Frame, through Mounting Rail [A] and into M8 Fastening Plate [K] (top photo). Loosely tighten.
3. Do this for the end of each Plank [J].

### NOTE

Ensure the front lip of your Plank tucks into the Platform Frame. You may need to angle the Plank slightly so the front lip of the Plank slips under the top face of the Frame.

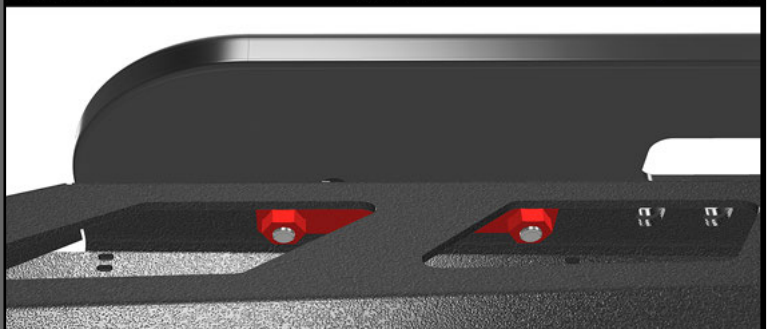
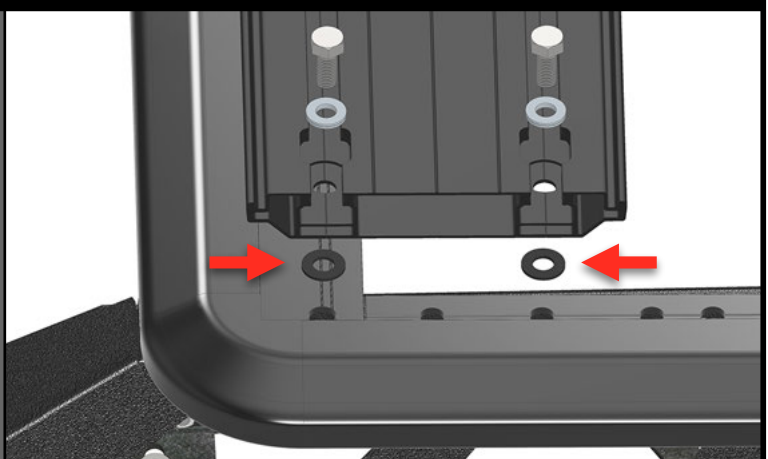

# 13

## Align MOUNTING RAILS.

1. Align the FRONT of the Mounting Rails [A] by pushing them inboard as much as possible. Align the REAR of the Mounting Rails [A] by pushing the outboard as much as possible.
2. Ensure the Platform Frame, Planks [J] and Mounting Rails [A] are centred on the roof of the vehicle.
3. Tighten (2) M8 Bolts at each end of the Planks [J].

**NOTE**

Recommended M8 Bolt Torque = 23Nm (Dry) or 18Nm (Anti-Seize).



# 14

## Secure MOUNTING RAILS.

1. Tighten (12) M6 Roof Bolts, (blue in photo).
2. Tighten (20) M6 x 16mm Hex Bolts [E], (red in photo).

**NOTE**

Recommended M6 Bolt Torque = 14Nm (Dry) or 11Nm (Anti-Seize). Do not over tighten M6 Roof Bolts, damage to roof nutserts can occur. Be sure to follow tightening sequence, otherwise joints may not sit flush.

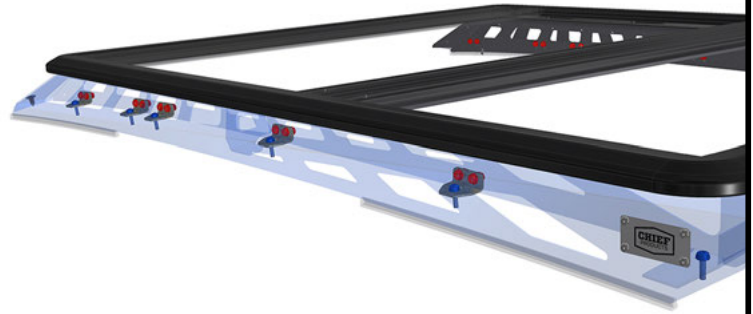

# 15

## Install PLANKS.

\* You can now install your Planks in whatever configuration best meets your needs.

1. Create (4) Bolt & Washer Combos, by adding (1) M8 Wedge-Lock Extended Washer [M] to (1) M8 x 20mm Hex Head Bolt [L].
2. Using (2) Bolt & Washer Combos and (1) M8 Fastening Plate [K] secure the end of each Plank [J]. Place M8 Fastening Plate [K] on underside of top face of Mounting Rail [A]. Insert each Bolt & Washer Combo through Plank [J], through M8 Flat Rubber Washer [N], through Platform Frame, through Mounting Rail [A] and into M8 Fastening Plate [K] (See Photos from Step 12).
3. Repeat 15.1 and 15.2 for each Plank [J].
4. Tighten all fasteners.

**NOTE**

If you're installing Tie-Down Plates, you can use a Tie-Down (Top) [V] to ensure perfect spacing between each Plank (BOTTOM PHOTO).

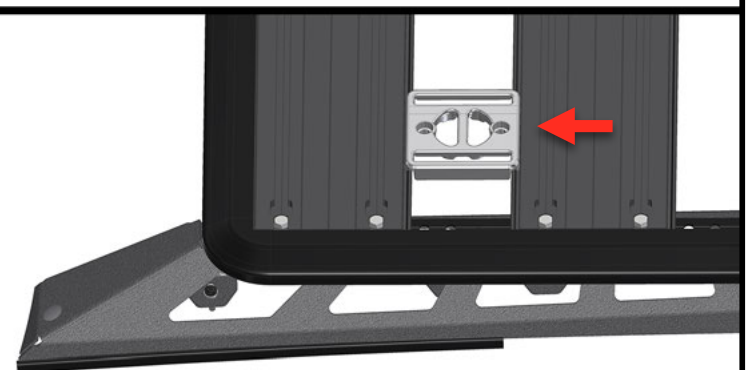

**IF YOU'RE INSTALLING:**

- TIE-DOWN PLATES (*Go To Page 10*).
- ROOF TOP TENT KIT (*Go To Page 11*).
- T-NUTS (*Go To Page 11*).

**16**

**Position PLANKS.**

1. Place (1) Plank [J] (with Wind Noise Suppressors installed from Step 7) into the location that best suits your needs.
2. Place (1) Plank [J] into the 2nd location that best suits your needs.

**NOTE**

Do not install remaining Planks at this time. This simple (2) Plank configuration provides the best access when tightening the Roof + Mounting Rail fasteners.

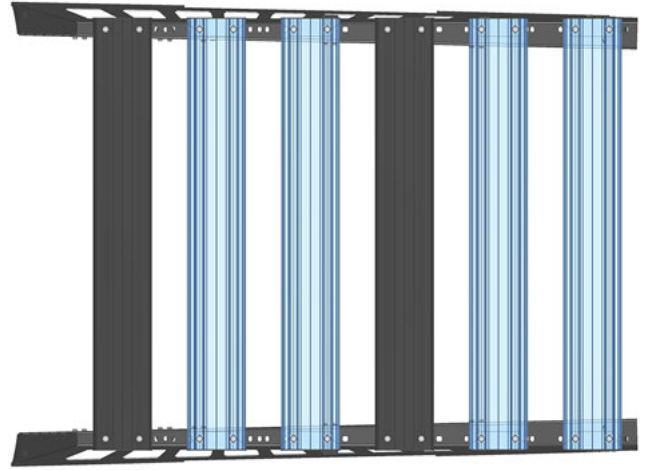

**17**

**Install 2 PLANKS.**

1. Create (8) Bolt & Washer Combos, by adding (1) M8 Wedge-Lock Extended Washer [M] to (1) M8 x 20mm Hex Head Bolt [L].
2. Using (2) Bolt & Washer Combos and (1) M8 Fastening Plate [K] secure the end of each Plank [J]. Place M8 Fastening Plate [K] on underside of top face of Mounting Rail [A] (bottom photo - M8 Fastening Plate in red). Insert each Bolt & Washer Combo through Plank [J], through (1) M8 Flat Rubber Washer [N] (red arrows), through End Cap [U], through Mounting Rail [A] and into M8 Fastening Plate [K] (top photo). Loosely tighten.
3. Do this for the end of each Plank [J].

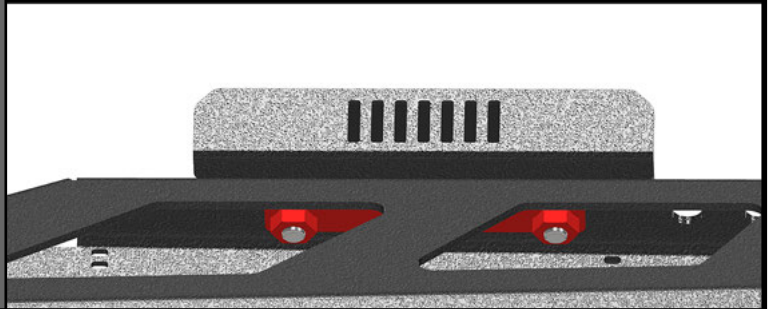
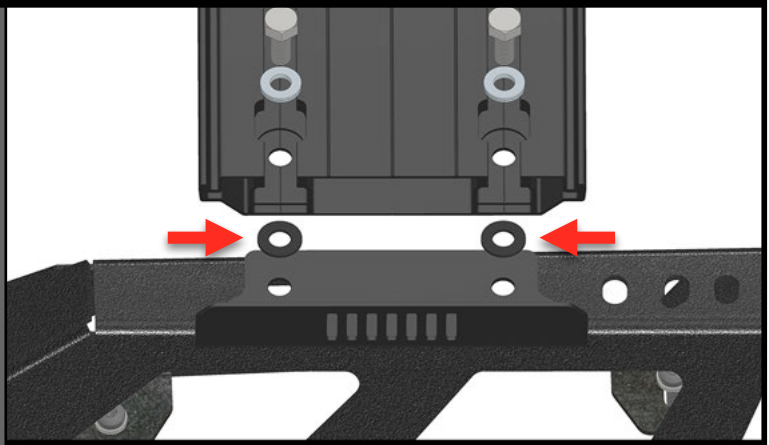

**18**

**Align MOUNTING RAILS.**

1. Align the FRONT of the Mounting Rails [A] by pushing them inboard as much as possible. Align the REAR of the Mounting Rails [A] by pushing the outboard as much as possible.
2. Ensure the Planks [J] and Mounting Rails [A] are centred on the roof of the vehicle.
3. Tighten (2) M8 Bolts at each end of the Planks [J].

**NOTE**

Recommended M8 Bolt Torque = 23Nm (Dry) or 18Nm (Anti-Seize).





## 19

### Secure MOUNTING RAILS.

1. Tighten (12) M6 Roof Bolts, (blue in photo).
2. Tighten (20) M6 x 16mm Hex Bolts [E], (red in photo).

#### NOTE

Recommended M6 Bolt Torque = 14Nm (Dry) or 11Nm (Anti-Seize). Do not over tighten M6 Roof Bolts, damage to roof nutserts can occur. Be sure to follow tightening sequence, otherwise joints may not sit flush.



## 20

### Install PLANKS.

\* You can now install your Planks in whatever configuration best meets your needs.

1. Create (4) Bolt & Washer Combos, by adding (1) M8 Wedge-Lock Extended Washer [M] to (1) M8 x 20mm Hex Head Bolt [L].
2. Using (2) Bolt & Washer Combos and (1) M8 Fastening Plate [K] secure the end of each Plank [J]. Place M8 Fastening Plate [K] on underside of top face of Mounting Rail [A]. Insert each Bolt & Washer Combo through Plank [J], through M8 Flat Rubber Washer [N], through End Cap [U], through Mounting Rail [A] and into M8 Fastening Plate [K] (See Photos from Step 17).
3. Repeat 20.1 and 20.2 for each Plank [J].
4. Tighten all fasteners.

#### NOTE

If you're installing Tie-Down Plates, you can use a Tie-Down (Top) [V] to ensure perfect spacing between each Plank (BOTTOM PHOTO).

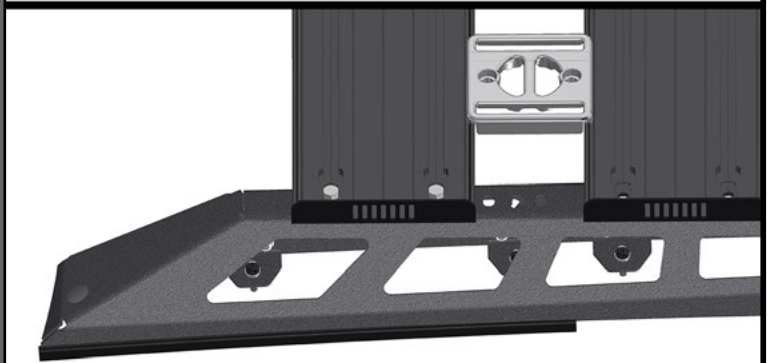

WK2 Roof Rack is now fully installed.

#### IF YOU'RE INSTALLING:

- TIE-DOWN PLATES (*Go To Page 10*).
- ROOF TOP TENT KIT (*Go To Page 11*).
- T-NUTS (*Go To Page 11*).

## TIE-DOWN PLATES

[START]

### 1 TIE-DOWN PLATES

#### Install TIE-DOWN PLATE.

1. Install Tie-Down (Top) [V] so the edges hook over the edges of the Planks [J] (See Photo).
2. Position Tie-Down (Bottom Plate) [W] under Tie-Down (Top) [V] with flush face facing upwards.
3. If installing T-Nuts [Z & AA] into Tie-Down Plate, see Step 2 now.
4. Create (2) Bolt & Washer Combos, by adding (1) M8 Wedge-Lock Extended Washer [Y] to (1) M8 x 20mm H5 Socket Button Head Screw [X].
5. Secure Tie-Down Plate to Planks [J] by inserting Bolt & Washer Combo through Tie-Down (Top) [V] and into Tie-Down (Bottom Plate) [W].
6. Position Tie-Down Plate in desired location. Tighten fasteners.

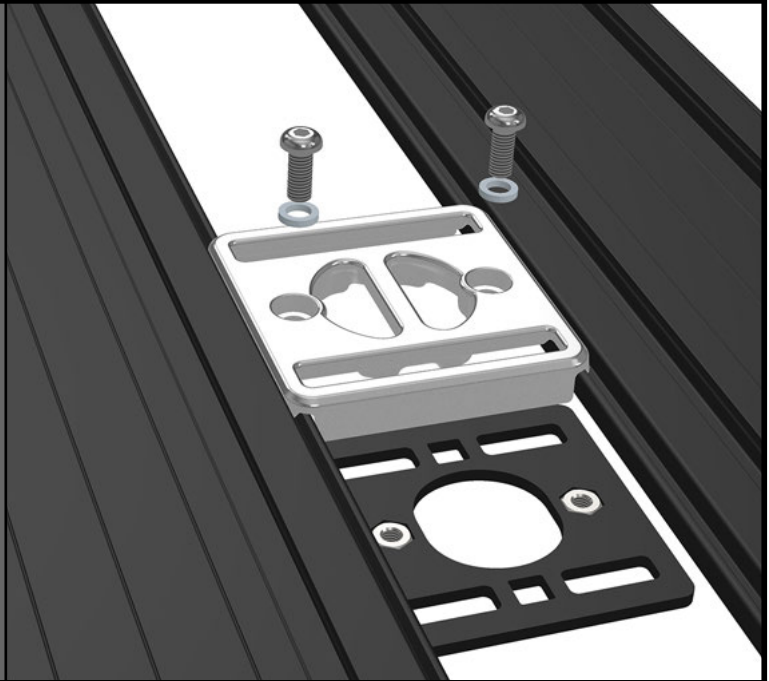

### 2 TIE-DOWN PLATES

#### Install T-NUTS.

1. Choose T-Nut location for intended use.
  - Upper position will capture T-Nut [Z & AA] within the adjustment slot and is suitable for most fastening requirements, (red in photo).
  - Lower position (below Bottom Plate) is not captive but is available for Heavy Duty applications (large spare tyre), (blue in photo).
2. If using Upper Position, position T-Nut [Z & AA] into adjustment slot, between Tie-Down (Top) [V] and Tie-Down (Bottom Plate) [W]. Tighten Tie-Down Plate fasteners. T-Nut can slide in adjustment slot, but cannot fall out.
3. If using Lower Position, hold T-Nut [Z & AA] below Tie-Down (Bottom Plate) [W] of a fully installed Tie-Down Plate. Insert Bolt through Tie-Down Plate adjustment slot and into T-Nut.

#### NOTE

Only install supplied T-Nuts (M8 & M10) when they are going to be used, otherwise they will move and make noise.

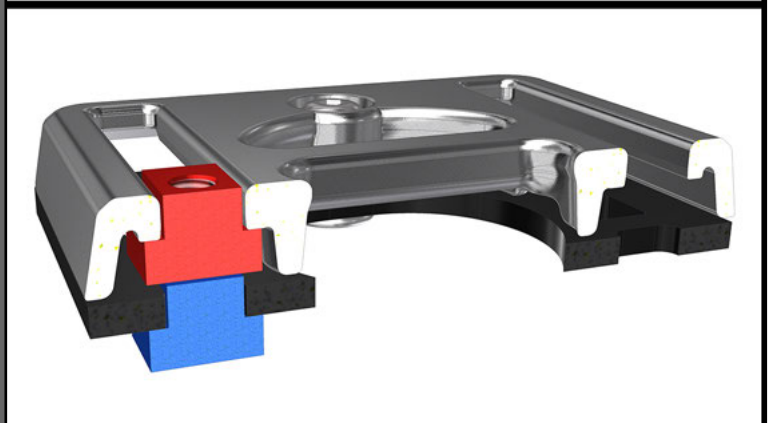

## TIE-DOWN PLATES

[END]

## ROOF TOP TENT KIT [START]

### 1 ROOF TOP TENT KIT

#### Position PLANKS.

1. Position each Plank (front & rear) to best suit your Roof Top Tent Manufacturers Recommendations.

#### NOTE

It is recommended that you position your Planks as far apart as possible for maximum support of your roof top tent.



### 2 ROOF TOP TENT KIT

#### Install BRACKETS.

1. Position (1) Roof Top Tent Bracket [BB] underneath your Plank [J] at each corner of your Roof Top Tent.
2. Insert the fasteners from your Roof Top Tent down through each Roof Top Tent Bracket [BB] and tighten finger tight. Once all (4) are installed, tighten the fasteners at each corner.

#### !!IMPORTANT!

If you have a sunroof, ensure your fasteners do not extend more than 20mm below the Roof Top Tent Brackets. If they do, they could cause interference when opening the sun roof.

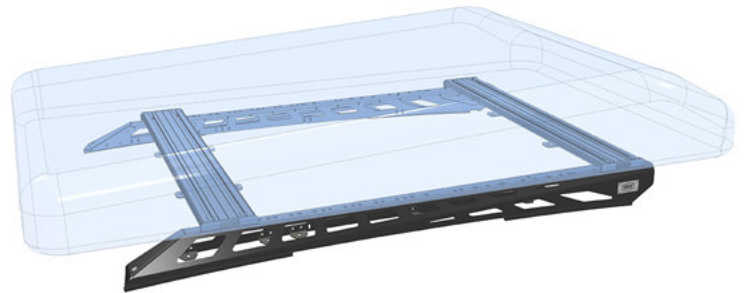

## ROOF TOP TENT KIT [END]

## T-NUTS [START]

### 1 T-NUTS

#### Using T-NUTS.

1. When using T-Nuts with a Plank [J], drop them into one of the (2) square holes at the end of each Plank. Slide T-Nut in the track to the desired position.
2. When using T-Nuts with a Tie-Down Plate, see Step 2 of Tie-Down Plate instructions (above).

#### NOTE

Only install T-Nuts when they are going to be used, otherwise they will move and make noise. T-Nuts are Grade 10.9 for maximum strength.



## T-NUTS [END]

# TROUBLESHOOTING

[START]

## 1 TROUBLESHOOTING

### NOISE → VIBRATIONS

1. Check that all M8 Flat Rubber Washers [N] have been installed properly. They should be positioned between Plank [J] and Platform Frame or End Cap [U].
2. If vibration persists; loosen (without removing) all fasteners retaining Planks [J] and Mounting Rails [A]. Tighten fasteners securing Mounting Rails [A], then tighten fasteners securing Planks [J].

## 1 TROUBLESHOOTING

### NOISE → WIND

1. Check that all Wind Noise Suppressors [D] have been installed properly, (Step 7 & Step 8).
2. Some Plank combinations/positions produce more wind noise than other combinations/positions. If wind noise persists; try repositioning your Planks or changing your Plank configuration.
3. When properly installed the WK2 Roof Rack has been designed (and extensively tested) to produce very little wind noise. Once you install lights, gear, etc. that can have a dramatic effect on the amount of wind noise you experience. If you have excessive wind noise, try repositioning the items on your rack.

# TROUBLESHOOTING

[END]

# MAINTENANCE

### FASTENERS

- Check fastener tightness regularly and tighten if required. We recommend checking fasteners after every large off-road trip.

### CORROSION PROTECTION

- After an off-road trip; rinse all mud, sand or debris off the product.
- After driving in salt water; rinse product thoroughly with fresh water.

### EXTRA CARE

- If you're planning to drive in a salty environment; spray fasteners with WD40 or an equivalent.
- If you're planning to drive in a salty environment; spray product with Lanolin or an equivalent.
- Spray deep scratches (before they rust) with touch up paint to help inhibit corrosion.





# SUPPORT

**Find answers online.**

[www.chiefproducts.com.au/pages/support](http://www.chiefproducts.com.au/pages/support)

**Having troubles? Make sure you've downloaded the most recent version of these instructions from our website. We occasionally make updates.**

[www.chiefproducts.com.au/installation/wk2-roof-rack.pdf](http://www.chiefproducts.com.au/installation/wk2-roof-rack.pdf)

**If you need additional help, send us an email.**

[support@chiefproducts.com.au](mailto:support@chiefproducts.com.au)

# SHARE

**Looking to share epic photos of your WK2?**

Send us your photos - Unboxing, Fully Installed, Painted-In-Mud or out Adventuring in some beautiful location. If you share with us, we'll share with our followers.

**UPLOAD**

[www.chiefproducts.com.au/share](http://www.chiefproducts.com.au/share)

**EMAIL**

[connect@chiefproducts.com.au](mailto:connect@chiefproducts.com.au)

**HASHTAG**

*#ChiefProducts #GrandAdventure*