

**Blaze and Blaze II Models Instructions to Users**

Precautions .....	1	Service and Maintenance during break-in Period .....	27
Vehicle Identification Number and Engine Number.....	2	Precautions you should take during the break-in period .....	27
Brief Introduction to your vehicle.....	3	Contents of Level 1 Service and Maintenance .....	28
Technical Specifications .....	6	Contents of Level 2 Service and Maintenance .....	28
Instrument cluster.....	10	Contents of Level 3 Service and Maintenance .....	28
Left control switches .....	11	Service and Maintenance of the Carburetor .....	29
Right control switches.....	12	Checking and changing the engine oil .....	30
Ignition switch .....	13	Service and Maintenance of the Spark Plug.....	31
Seat storage lock and Fuel tank.....	14	Service and Maintenance of the Air Filter.....	32
Vehicle Operation .....	16	Adjusting the throttle.....	33
Environmental protection device .....	17	Service and Maintenance of the Front Brake .....	34
Vehicle Load .....	18	Service and Maintenance of the Rear Brake .....	35
Tool kit (included).....	18	Checking the brake light switches.....	36
<b>Operating Instructions</b>		Adjusting the idle speed .....	36
Basic vehicle checks and maintenance levels .....	19	Service and Maintenance of the Front and Rear Tires .....	37
Kick starting the engine .....	23	Service and Maintenance of the Environmental Protection Device .....	39
Electric starting the engine.....	24	Service and Maintenance of the battery .....	40
Parking the vehicle.....	25	Service and Maintenance of the fuse.....	41
<b>Service and Maintenance</b>		Service and Maintenance of the horn .....	41
Regular Service and Maintenance .....	26	Storage of the vehicle .....	42
Requirements on Service and Maintenance .....	26	Service and Maintenance Interval Table .....	43
		Service and Maintenance Interval Table for Lubricated Parts ....	44
		<b>Common Faults and Troubleshooting</b> .....	45
		<b>Schematic Wiring Diagram</b> .....	49



**Please read this User's Manual carefully before operating this vehicle!**

### **Warning**

- \* Please observe all traffic laws and regulations.
- \* All users must have a valid driver's license. Operating a vehicle with a 150cc sized engine (the Blaze II) may require extra licensing endorsements. Please check your local motor vehicle laws to be sure.
- \* NEVER hang anything on the handlebars while operating the vehicle
- \* Always wear a helmet, eye protection, and gloves for your safety.
- \* This vehicle is for road use only.
- \* Always be aware that the exhaust and muffler will become hot when operating your vehicle. Do not touch the exhaust assembly during or shortly after operating the vehicle as not to burn yourself.
- \* For your safety, always wear the appropriate clothing and footwear while operating your vehicle.

### **Caution**

- \* Please check the accessories and various documents delivered with the vehicle according to the packing list.
- \* Strictly follow the listed weight limit of the vehicle.
- \* Do not modify any part of the vehicle. Modifying the vehicle can decrease the engine life, the reliability of your vehicle and compromise your safety.
- \* Only premium fuel should be used in the vehicle. (90+ octane) Otherwise, the engine performance and fuel economy, may be compromised, and the service life of the vehicle will be shortened. Use of lesser rated fuel will void the engine coverage of your warranty.
- \* All repairs and required service must be completed at a Wolf Brand Scooters authorized service center. All required service must be done to the vehicle following the published service intervals to maintain the vehicle's warranty.
- \* Not completing required service will void your warranty.

### **Suggestion**

- \* This manual provides important information regarding the vehicle. If the vehicle is transferred to any other person, this manual should be transferred together with the vehicle.

## Vehicle Identification Number (VIN) and Engine Number

The Vehicle Identification Number (VIN), Engine Number and Quality Certificate, are used to obtain the registration and license plate for your new vehicle.



Vehicle Identification Number (VIN) is printed on the vertical tube of the frame. Behind this small cover on the “knee board”.



The product nameplate is riveted on the right lower part of the frame.



The Engine Number is printed on the left lower part of the crankcase.

Please note your vehicles specific numbers for future reference here:

Vin:

Engine Number:

## A Brief Introduction to the vehicle

1. Headlight
2. Left front turn signal
3. Seat cushion and storage
4. Rear luggage carrier
5. Disc brake
6. Side stand
7. Center stand
8. Kick Start
9. Air filter assembly



## A Brief Introduction to the vehicle



1. Tail light/ Brake light
2. Helmet hook
3. Right front turn signal
4. Muffler
5. Battery
6. Front brake lever

## A Brief Introduction to the vehicle

1. Rearview mirrors
2. Left grip
3. Left switch assembly
4. Instrument cluster
5. Ignition
6. Right switch assembly
7. Throttle grip



## Technical Specifications

## Blaze (49cc)

Engine	QMB139 Long Case
Displacement	49cc (Single Cylinder, 4 Stroke)
Cooling System	Air Cooled
Compression Ratio	10.2 : 1
Bore x Stroke	39mm x 41mm
Max Power	2.99 HP @ 7500 RPM
Max Torque	3.10 Nm @ 5500 RPM
Idle Speed	1600 RPM (+/- 100)
Engine Oil	10W/40 Standard or 5W/40 Synthetic- Motorcycle
Gearbox Oil	SAE 80W/90
Transmission Type	CVT (Continuously Variable Transmission)



**Technical Specifications**

**Blaze (49cc)**

Belt Size	729 - 17.5 - 30
Ignition Type	CDI (Capacitor Discharge Ignition)
Spark Plug	NGK C7HSA
Battery	12 Volt - 7 Amp (YTX7A-BS)
Starting System	Electric / Kick
Front Tire	120/70 - 12 (Set to between 32 - 40 psi)
Rear Tire	120/70 - 12 (Set to between 32 - 40 psi)
Brakes (Front/Rear)	Disc / Drum
Scooter Dimensions LxWxH	72" x 27.5" x 45"
Seat Height	33"
Fuel Tank Capacity	1.66 Gallons
Fuel Economy	90+ MPG
Scooter Weight	205 lbs

## Technical Specifications

## Blaze II (150cc)

Engine	GY6 - 157QMJ - Long Case
Displacement	150cc (Single Cylinder, 4 Stroke)
Cooling System	Air Cooled
Compression Ratio	10.2 : 1
Bore x Stroke	57.4mm x 57.8mm
Max Power	8.38 HP @ 7500 RPM
Max Torque	9.4 Nm @ 5500 RPM
Idle Speed	1700 RPM (+/- 100)
Engine Oil	10W/40 Standard or 5W/40 Synthetic- Motorcycle
Gearbox Oil	SAE 80W/90
Transmission Type	CVT (Continuously Variable Transmission)

**Technical Specifications**

**Blaze II (150cc)**

Belt Size	835 - 20 - 30
Ignition Type	CDI (Capacitor Discharge Ignition)
Spark Plug	NGK C7HSA
Battery	12 Volt - 7 Amp (YTX7A-BS)
Starting System	Electric / Kick
Front Tire	120/70 x 12 (Set to 32-40 psi)
Rear Tire	120/70 x 12 (Set to 32-40 psi)
Brakes (Front/Rear)	Disc / Drum
Scooter Dimensions LxWxH	72" x 27.5" x 45"
Seat Height	33"
Fuel Tank Capacity	1.6 Gallons
Fuel Economy	75+ MPG
Scooter Weight	245 lbs

## Instrument cluster

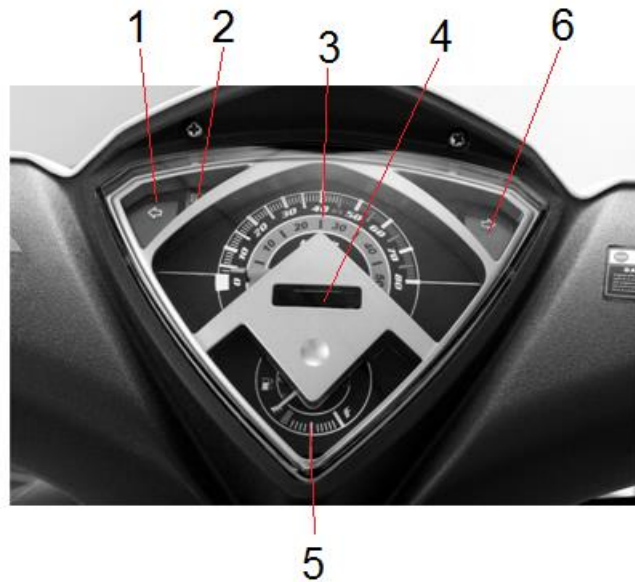

**1 Left turn indicator lamp:**

When the turning indicator lamp “←” flashes, it indicates that the “left turn signal” is on.

**2 High beam indicator lamp:**

When the blue high beam indicator lamp “☰” is on, it indicates that the headlight is operating in “High Beam” mode

**3 Speedometer:**

It indicates the current speed of the vehicle.

**4 Odometer:**

Records the vehicles accumulated miles.

**5 Fuel gauge:**

Indicates how much fuel is in the fuel tank of the vehicle.

**6 Right turn indicator lamp:**

When the right turning indicator lamp “→” flashes, it indicates that The “right turn signal” is on.

## Left switch assembly

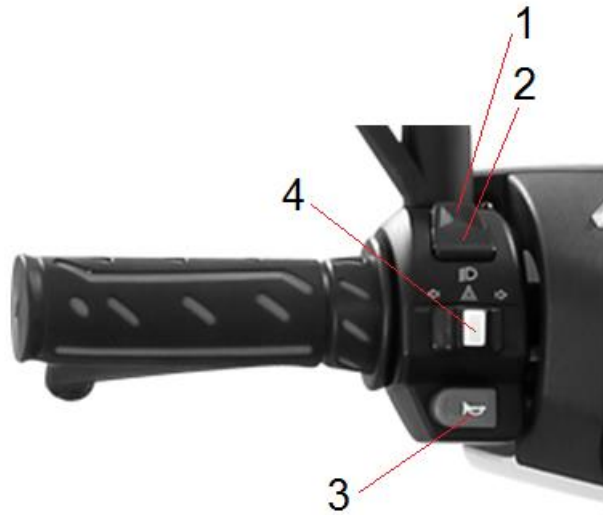

**1 High beam headlamp switch:**

To use the “High beam lamp”, turn the switch to the upper “”. position



**2 Low beam headlamp switch:**

To use the “Low beam lamp”, turn the switch to the lower “”. Position.

**3 Horn button:**

To use the horn, press the “” button.

**4 Turn signal switch:**

When making a turn with the vehicle, move this switch to “” or “” to signal to other motorists that you are turning left or right. When you complete your turn, press the center white button to switch the turn signal off.

## Right switch assembly



### 1 Electric start button:

This is pressed when you want to start the vehicle. Press the yellow “” button while holding in brake levers.

### 2 Throttle grip:

When the engine is on, twist to accelerate.

### 3 The Cut Off or Run /Stop Switch:

Electrical power for the engine is turned on when the switch is set to

The position marked “”

This switch must be set to this position for the engine to start and run

Electrical power for the engine is turned off when the switch is set to the

position marked “” The engine will turn off when this switch is set to this position

## Ignition



### 1) Ignition On:

Insert the key and turn the ignition lock to “” this will turn the vehicle electrical system on.



### 2) Ignition Off:

Turn the ignition lock to “” to turn the vehicle electrical system off. The vehicle key can now be removed.



### 3) Steering lock:

When stopped, turn the handle bars all the way to the left, push the key inwards and turn to “” to lock the steering. The key can then be removed.



When the vehicle is parked, as described in detail #3, turn the Ignition lock switch to “” to lock the steering to help prevent the vehicle from being stolen

## Seat Storage lock



Seat: Insert the ignition lock key into the seat lock and turn it clockwise to open the seat cushion. This will give you access to the under-seat storage bin and the fuel tank cap

## Fuel tank

Opening the fuel tank: Twist cap counter clockwise 90 degrees and remove.



Closing the fuel tank: Insert the fuel cap in the fuel tank opening aligning the tabs on the cap with the notches in the tank neck and turn it clockwise.



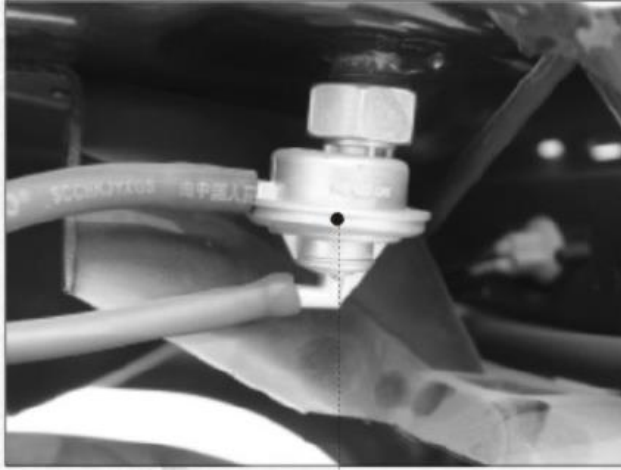

Bolt on Fuel valve or “switch”, this valve is opened by the vacuum pressure produced by the engine, it allows fuel to enter the carburetor via gravity. It closes when the engine turns off.

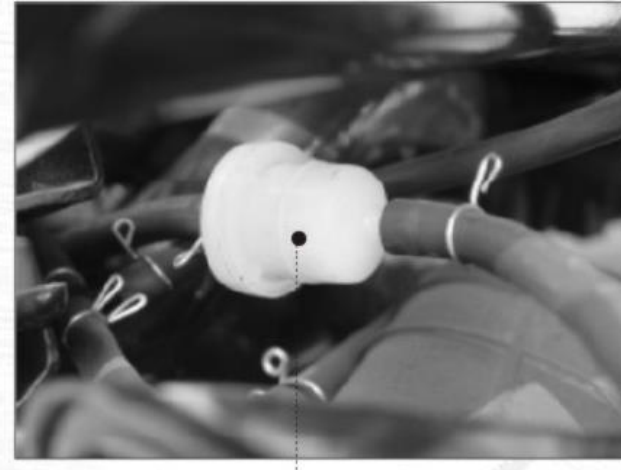

Fuel filter: This is positioned in the main fuel line; the fuel passes through here between the fuel tank and the carburetor to ensure clean fuel is entering the carburetor.

### **Warning**

- \* Do not over fill or “top off” the fuel tank.
- \* Gasoline vapors are flammable. The vehicle should be turned off before opening the fuel tank cap. Fuel should be dispensed in a well-ventilated location.
- \* While dispensing fuel, smoking is strictly forbidden nor should it be done close to any open flame or spark. Before refueling, ground yourself by touching any metal part of the vehicle. This will dissipate any static electricity present and prevent static sparks that could ignite any fuel vapors that will be present during refueling.

### **Caution**

- \* Only 90 + Octane rated fuel should be used.

## Vehicle Operation

All Wolf Brand Scooters use the dry, centrifugal clutch and belt driven CVT (Continuously Variable Transmission). If there is an issue with the clutch, belt or variator, take your vehicle to an authorized Wolf Brand Scooter dealership for service.



Front brake: This is the right lever when you're sitting on the vehicle. It is a disc brake.



Rear brake: This is the left lever when you're sitting on the vehicle. It is a drum brake.



Automatic clutch: The CVT assembly allows smooth acceleration without the need for gear changes.



Kick Starter: This is used for manually starting the engine. The vehicle must be on the main stand, the ignition must be on and the brake levers applied while you kick start the engine.

**Environmental protection device**

The environmental protection device is mainly a two-in-one air compensating valve (air pump) combining a one-way leaf valve and a secondary air control valve. By making use of the engines vacuum pulsation, the air pump controls the amount of air needed to enter the exhaust port through the one-way leaf valve and the secondary air control valve. This fresh air enters the exhaust passage of the engine under the action of the air pump. Unburned fuel vapor discharged from the engine in its exhaust is then consumed. Thusly this device reduces the exhaust pollution of the vehicle, and ensures that the vehicles exhaust meets National Stage III emission standards.

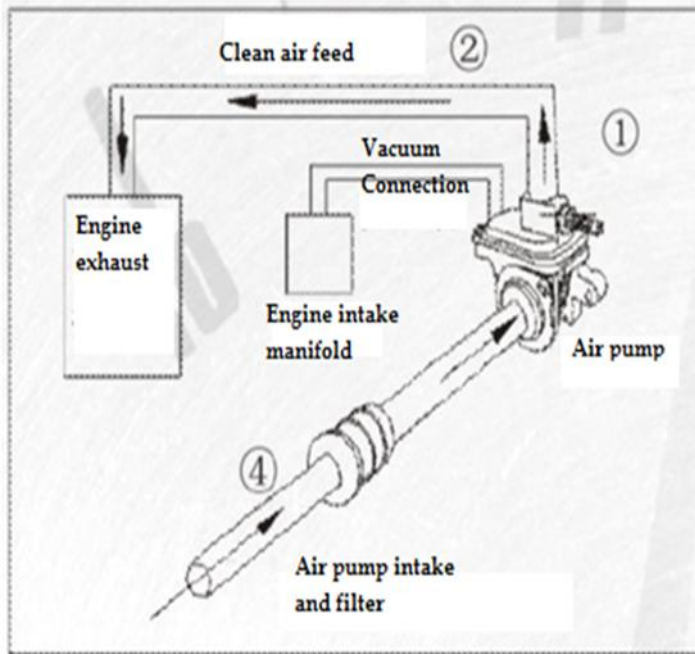

**Emission Standards of Motorcycles (Stage III , under the running mode)**

Unit: g/km

Emitted pollutants	Two-wheel vehicle
CO	2.0
HC	0.8
NOx	0.15

**Emission Standards of Mopeds (Stage III , under the running mode)**

Unit: g/km

Emitted pollutants	Two-wheel vehicle
CO	1.0
HC + NOx	1.2

**Limits of exhaust pollutants of motorcycle/mopeds under idle conditions**

In case of idle type approval test, the volume concentration of emitted CO is  $\leq 3.8\%$ ; and the volume concentration of emitted HC is  $\leq 800 \times 10^{-6}$ ;

In case of Production consistency check test, the volume concentration of emitted CO is  $\leq 4.0\%$ ; and the volume concentration of emitted HC is  $\leq 1000 \times 10^{-6}$ .

**Vehicle Load**

The vehicles maximum load of 330 lbs. must be strictly observed. Otherwise, the safety and stability of the vehicle may be compromised. This weight limit includes Rider, passenger, their gear, and any luggage.

- \* Belongings in the seat storage bucket must be secured to prevent their shifting while the vehicle is in motion.
- \* NEVER hang anything from the handle bars while operating the vehicle. This will dangerously compromise the handling of the vehicle
- \* The load of the rear carrier must not exceed 12 lbs.



**Tool kit (Included)**

Common service and maintenance tools are delivered together with the vehicle.

The tool kit will be found in the under-seat storage bucket.

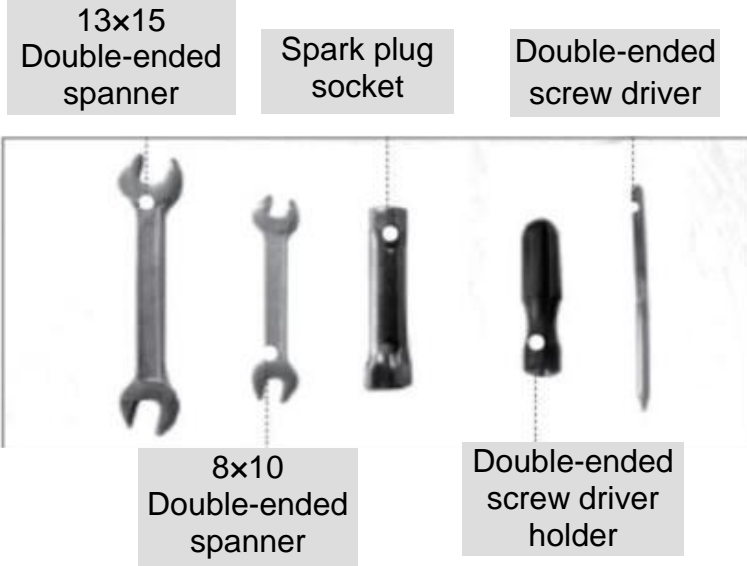

## Basic Vehicle Checks and Maintenance Levels:

There are regular checks that you should do on your vehicle on a regular basis to ensure that the vehicle is always safe to use and to keep it in good condition. Keeping it in good condition will also help in maintaining the vehicles optimal performance.

1. When starting the engine after it's been sitting for more than a few hours and after cleaning the vehicle, start the engine, and let it run at idle for several minutes.
2. Check for any fluid leaks.
3. Check for any loose connections.
4. Check to ensure that all lights are working.

Different levels of maintenance and service will be taken for different odometer readings and performance conditions of the vehicle:

The very first oil change should be done between 300~500 miles to replace the "break-in" oil with fresh oil. The valve clearances should be checked and adjusted if necessary.

Level 1: Service and Maintenance: Odometer reading 1000~1500 miles. Oil change, valve checking/adjusting and lubricate any necessary parts and check nuts and bolts and secure if necessary. (See the Service and Maintenance section for more details).

Level 2: Service and Maintenance: Odometer reading 2000~2500 miles. Oil change, valve checking/adjusting and lubricate any necessary parts and check nuts and bolts and secure if necessary. (See the Service and Maintenance section for more details).

Level 3: Service and Maintenance: Odometer reading 3000~3500 miles. Oil change, valve checking/adjusting and lubricate any necessary parts and check nuts and bolts and secure if necessary. Disassemble necessary parts and check for any hidden hazards/wear.

Oil changes and basic service should be done every 1000 miles.

**\*\*ALL WORK SHOULD BE DONE AT AN AUTHORIZED WOLF DEALERSHIP TO ENSURE THE WARRANTY DOES NOT GET VOIDED\*\***

### Pre-operation vehicle checks

Before running the vehicle, please follow the following steps to check it, and ensure your driving safety.



Turn the ignition on and ensure all turn signals and other lights are working.



Check the fuel gauge to ensure you have enough gas to get to your destination.



Ensure you have enough gas for your trip and ensure the gas cap is secured properly.



Place the vehicle on the main stand and check the oil level. Always make sure the vehicle has enough oil. See the “Service and Maintenance” section for how to make this check



Check your steering by moving from left to right. The handlebar should move easily and smoothly with no play or binding.



Check that the throttle grip rotates smoothly and freely. If not, the throttle cable may need replacing.





Check for any fluid leaks under the engine.

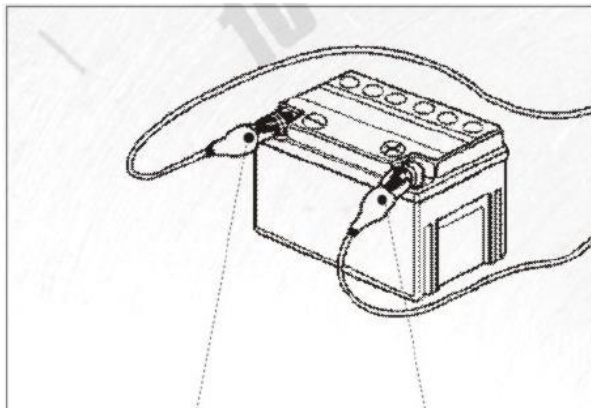

Check the terminals on the battery to ensure they are clean and tight.



Check the pressure of the front tire. Set it to between 32 and 40 P.S.I. Check for abnormal wear on the tire tread and side walls. Check air pressure when tires are cold



Check the pressure of the rear tire. Set it to between 32 and 40 P.S.I. Check for abnormal wear on the tire tread and side walls. Check air pressure when tires are cold



The throttle grip should have a slight amount of free play in it. About 10-20 mm (0.393-0.787 inch)



Check that the head light, turn signals and indicator lamps work properly.



Check that the rear brake lever has the correct amount of free play in it. About 20-30 mm (0.787-1.181 inch)



Check that the tail light and brake lights work properly.



## Using the kick starter



1) Turn the ignition on.



2) The vehicle should be put on the main stand and you need to hold the brake levers to allow the engine to start.



3) Pull out the foot lever, place your foot on it and push firmly and quickly all the way down. Let the arm return to its horizontal position before you try to kick start it again. Repeat this motion.



4) Twist the throttle slightly to allow more gas flow as you kick the engine over. Once started, let the engine warm up before revving the engine to a higher RPM.

## Using the Electric Starter

The duration of each electric startup attempt should not exceed 5 seconds, and the interval between attempts should never be less than 10 seconds. If 3 startup attempts fail consecutively, the vehicle must be checked.



First, insert the key into the ignition switch lock, and turn it to the “ON” position.



Apply either the front brakes...



... or apply the rear brakes, these will activate a starter safety switch and the engine will turn over



While holding the brake handles, push the electric start button with your right thumb. Twist the accelerator a small amount with your right hand to add an appropriate amount of fuel and the engine will start

## Parking the vehicle



When you need to park the vehicle, you have 2 different methods to support it, the side stand, or the main stand.

**You should turn your engine off before using either of these stands.**

### Using the side stand:

Holding the vehicle upright, you use your foot to put the side stand down. Once all the way down, you can then lean the vehicle onto it.

**NOTE:** With this side stand down, a safety switch is activated and the vehicle will not start

### Using the main stand:

Holding the vehicle upright, place your left hand on the left-hand grip and your right hand on the rear rack. Keeping the vehicle vertical, you put your right foot on the main stand and press down while pulling up with your right hand.



To lock the steering column, turn the handlebars all the way to the left, push the key inwards and turn the ignition to the “” position to prevent the vehicle from being stolen easily.

### Regular Service and Maintenance

Throughout the life of the vehicle, usage will inevitably cause wear of its mechanical parts. Regular maintenance will prolong the life of the vehicle.

#### Requirements on Service and Maintenance

1. Keep the engine clean, make sure there are no fluid leaks
2. Confirm that the automatic clutch does not show any indication of slipping on acceleration or that it makes any abnormal noise. Also confirm that your throttle operates smoothly and without binding.
3. Ensure that the brakes work well and meet necessary requirements. Check that the wheels spin freely once brakes are released and that there is no friction noise when brakes are not on.
4. The front forks and rear shock absorbers should compress and rebound smoothly. Check for leaks around the seals.
5. The air pressure of the tires should be set to the required P.S.I.
6. Check for loose electrical connections throughout the vehicle.

7. All mechanical parts should be lubricated.
8. The cable connections to the battery terminals should be clean and tight and the battery should be secured properly within the vehicles battery box.
9. Any corrosion on any metal parts should be taken care of as soon as possible to prevent spreading.

#### Service and Maintenance during the break in period

How a new vehicle is broken in directly affects the service life of the vehicle. Within the first 500 miles of a new vehicles life, the driving speed should not exceed 30 MPH, and the rider should vary their speed regularly.

**Precautions you should follow during the break-in period of a new vehicle**

1. Within the break-in period, replace the oil every 300 miles, and clean the oil filter screen.
2. Regularly check for loose electrical connections, and tighten if found.
3. Regularly check whether the engine, drive train and braking system overheat, and whether there is enough lubricating oil on each lubricated part. If any overheating occurs, the reason should be found and rectified immediately.
4. Regularly check the tightness of the drive belt, the free travel of the front and rear brakes, throttle grip and the handle bar movement. Adjust them if necessary.
5. Within the break-in period, ride the vehicle only when the engine is warmed up. First run it at low speed for 1~2 miles, and then run it at higher speeds.
6. To reduce vibration and impact loads, the vehicle should run on a level road with good road conditions whenever possible.
7. During the break-in period, carrying any unnecessary weight should be avoided. Otherwise, the drive train will wear faster.
8. Try to avoid heavy braking and braking for long periods of time.
9. Strictly control the speed of the vehicle, varying the speed regularly while riding.

**Contents of Level 1 Service and Maintenance**

Level 1 Service and Maintenance should be performed every 500~1000 miles. Its main contents are as follows:

1. Drain oil and refill to correct level with the correct weight motorcycle oil. Standard 15W-40 or synthetic 5w-40.
2. Adjust the travel of the front brake handle to 10mm~20mm (0.394-0.787 inch), and adjust the rear brake handle to 20mm~30mm (0.787-1.181 inch).
3. Adjust the travel of the throttle cable to 2mm~6mm (0.078-0.236 inch), and lubricate the throttle grip and the throttle cable.
4. Clean the carburetor, fuel tank, oil filter screen and air filter.
5. Adjust the idle speed of the carburetor.
6. Remove the carbon deposits on the spark plug, and adjust the electrode gap of the spark plug to 0.025" or 0.6mm~0.7mm.
7. Remove the battery and charge it.
8. Check and tighten all bolts and nuts of all exposed parts.
9. Check the tightness of all connections of the electrical system.
10. Adjust the engine valve lash: intake valve to 0.03-0.05mm (0.001-0.002 inch); and the exhaust valve to 0.05-0.07mm (0.002-0.003 inch).
11. Store the vehicle in the best possible conditions.

**Contents of Level 2 Service and Maintenance**

Level 2 Service and Maintenance should be performed every 2000~4000 miles:

1. Drain oil and refill to correct level with the correct weight motorcycle oil. Standard 15w-40 or synthetic 5w-40
2. Disassemble the top end cylinder assembly of the engine. Inspect for excessive wear and remove any carbon deposits from parts such as, the piston, piston rings, and cylinder head. Lubricate and reassemble.
3. Check the wear of the clutch friction lining, the rear brake shoes, and front brake pads. Replace as needed.
4. Clean the carburetor, air filter, fuel tank, fuel filter, etc. Replace if needed
5. Clean the upper and lower bearings of the steering column and re-pack with grease.
6. Clean and lubricate all the cables on the vehicle and replace if any fraying or excessive wear is seen.
7. Flush the transmission and check all components and refill with new oil.

**Contents of Level 3 Service and Maintenance**

Level 3 Service and Maintenance should be performed every 5000~8000 miles.

1. Drain oil and refill to correct level with the correct weight motorcycle oil. Standard 15w-40 or synthetic 5w-40
2. Ensure the emissions system is working correctly.
3. Ensure the electric start system is working.
4. Check the front and rear automatic clutches and the drive system for normal operation.
5. Check whether there are any cracks, erosion, or serious wear on each gear tooth of the rear transmission box.
6. Disassemble the top end cylinder assembly of the engine. Inspect for excessive wear and remove any carbon deposits from the parts therein. Check the clearance between the piston and the cylinder wall, and the smaller head of the crank connecting rod and the piston pin.
7. Ensure the front and rear shocks are in good condition and their mounts are in good condition.
8. Ensure the fuel system is running cleanly. Inspect all fuel and vacuum lines for wear and replace the fuel filter
9. Check the instruments and the electric system and ensure normal operation.
10. Disassemble the vehicle and check the steering column, engine mounts and other substantial parts and make sure there is enough lubrication and that you don't find any excessive wear.

### Service and Maintenance for the Carburetor

For maximum performance and reliability, it is important the carburetor is adjusted properly. Failure to do so will affect starting; idle, as well as the overall vehicles performance.

#### The carburetor should be serviced and maintained as follows:

1. Regularly check all connections and fittings on the carburetor. A poor fit between the intake manifold and carburetor can result in hard starting, poor performance and lower gas mileage.
2. Check the rubber fuel lines for signs of weathering. If any cracks or deterioration are found, replace them.
3. Start and drive your vehicle often. Gasoline left sitting for a long period of time will start to break down, becoming "stale". The longer a vehicle sits the more likely the carburetor is to develop issues due to stale fuel contamination.
4. If the vehicle is to be stored for any length of time longer than 2 weeks, the fuel in the carburetor bowl and fuel tank must be drained from the vehicle into an approved container for use elsewhere. Failure to do so will result in a contaminated, "clogged" carburetor. This will cause hard starting and poor performance. The carburetor will then have to removed and thoroughly cleaned or, as in many cases, replaced.

Draining the fuel is quite simple. You will find a length of fuel line running from the bottom of the carburetor to a bracket on the frame. In that bracket, there will be a brass screw plug that when removed will allow fuel to drain out of the carburetor bowl. Fuel can be easily syphoned from the fuel tank.

### Check and Replacement of Lubricating Oil



With the vehicle on the center kick stand, unscrew the oil dipstick and wipe clean with a rag. Insert the dipstick, pull out, and check the level and color of the oil. The oil level should always be between the upper and lower oil level markings on the dipstick.



Following the service intervals in this manual, drain and replace the oil as necessary. The 17mm bolt on the bottom of the engine needs to be removed to drain the oil. Be sure to clean the mesh filter screen before reinstallation.

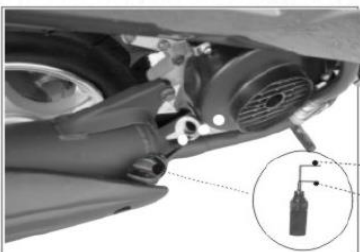

After the engine has drained completely, reinstall the mesh screen into the spring. Place the spring into the drain plug and reattach to the engine. Refill the engine with oil.

Lower oil level marking  
Upper oil level marking

### ⚠ Caution

#### Checking and Replacing Engine Oil

To ensure an accurate reading when checking the engine oil, place the vehicle on the center main stand. Only check the oil level after the engine has been shut off for at least 5 minutes. Be aware the engine, exhaust and engine oil will be extremely hot if the engine has been running. It is recommended you allow the engine to cool for at least 30 minutes after a long drive before checking.

- Remove oil cap. Note if there is oil on the dipstick. A lack of oil on the dipstick indicates a low oil level.
- Wipe the dipstick clean and insert into engine. Quickly withdraw the dipstick and note the oil level. If there is no oil on the dipstick, oil will need to be added.
- Note the color of the oil. Very black oil indicates the oil must be drained and replaced.
- To drain the engine oil, loosen the 17mm oil drain plug on the bottom right hand side of the engine, directly underneath the black engine shroud.
- Allow oil to drain completely. Not allowing all the oil to drain will result in residual oil left in the crankcase which will alter the amount needed to fill the engine.
- Inspect oil filter and clean if necessary.
- Reattach oil drain plug with spring and filter installed.
- Fill with ~750mL (25 oz.) of 15W-40 (or 5W-40 if synthetic) engine oil through the oil dipstick opening.
- Insert dipstick and withdraw to verify correct oil level.
- Tighten dipstick and inspect for leaks.



**Service and Maintenance of the Spark Plug**



It is normal for the spark plug to be light brown. This indicates a proper air fuel mixture.

Check the electrode gap of the spark plug with a gauge and adjust the gap to 0.025 inches.

Remove the spark plug from the engine. If the color of the insulator skirt of the spark plug is brown it indicates that the carburetor is adjusted properly. Any signs of buildup on the plug should be noted as this could be a sign of an incorrect carburetor adjustment.

**Cleaning the Spark Plug**

Inspect the spark plug for carbon buildup. If there are noticeable deposits or wear on the spark plug, replace.

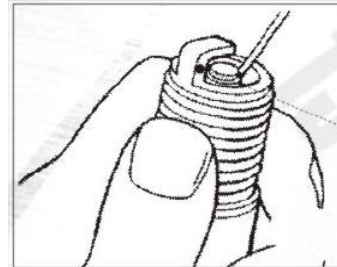

Correct spark plug gap helps fuel economy and performance. Incorrectly gapped spark plugs can lead to hard starting and poor performance. Always replace the spark plug with the original NGK replacement.



When removing and tightening the spark plug, be sure to use the correctly sized socket. Improper removal can result in spark plug damage that can result in costly repairs.

### Service and Maintenance for the Air Filter

When dust builds up in the filter element of the air filter assembly, it results in an increased resistance to air flow through the air intake system. This leads to an overly rich fuel/air mixture that can reduce power and increase fuel consumption. It is important the air filter be cleaned or replaced on a regular basis. Riding in dusty conditions will require more frequent filter maintenance.

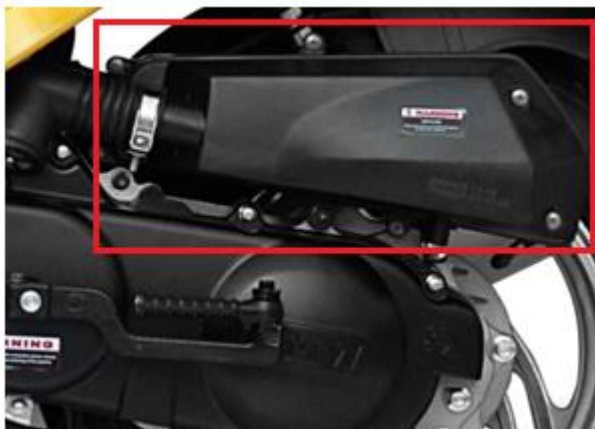

Take off the screws for the air filter cover, and remove the air filter cover. Check whether there is dust and dirt on the sponge of the filter element. Remove the air filter and wipe off the dust inside the air filter with clean and dry cloth.

Paper based filters are a disposable item and just need to be replaced. You can find them at your Wolf Brand dealership

Foam or cloth filter elements can be cleaned and reused numerous times. You can wash them in warm water and a simple detergent. Once dry you must treat them with a light oil before reinstallation for them to filter correctly.

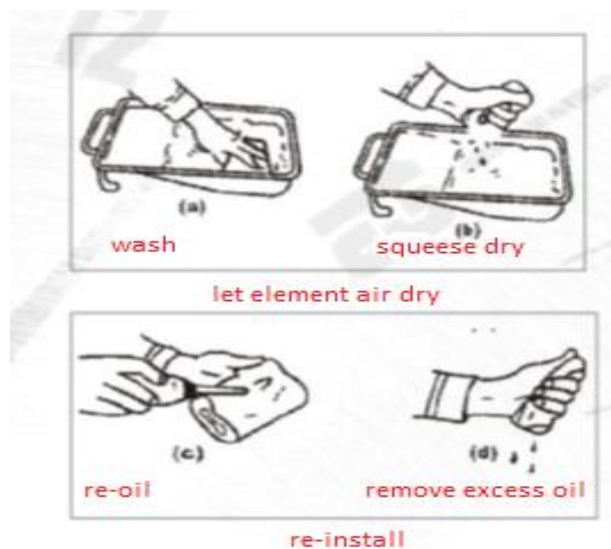

#### ⚠ Caution

- \* Do not use the following cleaning agents to clean paper filter elements: Gasoline, low ignition-point solvent, acid, alkaline or organic volatile oil.

**Adjustment of the throttle grip**

Check whether the free travel of the throttle is within the specified range and adjust it if necessary. Please follow the following steps to adjust the free travel.

1. First, loosen the locking nut.
2. Spinning the regulator will extend or shorten the free travel of the throttle.
3. When the desired setting is reached, tighten the locking nut and slide the protective covering back over the regulator.



The throttle grip should work smoothly. Any signs of sticking or binding should be addressed prior to riding the vehicle.

**Service and Maintenance for the Front Brake**

Most models use a front disc brake, which features high heat dissipation and increases performance.

**Adjustment of the front disc brake**

1. Place the vehicle on the main stand.
2. Adjust the regulating nut of the front brake to adjust the free travel of the front braking handgrip to 1/4 – 1/2 Inch.

Adjust the free travel of the front braking handgrip to 1/4 and 1/2 inch.



**Service and Maintenance for the Front Brake**

Disc brake



\* Check the travel of the brake lever when applied. Excessive travel could indicate worn pads or air in the brake fluid. Either of which need to be addressed prior to riding.

\* Check for the wear on the front disc rotor. Any signs of warping or irregularities in the surface of the brake rotor can cause vibration, and lower braking force. This can dangerously increase the stopping distance of the vehicle. Replace when needed.

## Service and Maintenance for the Rear Brake

Adjustment of the rear drum brake:

- \* First, use the main stand to prop up the rear wheel of the vehicle and then adjust the free travel of the rear brake by screwing in or out the nut on the end of the rear brake cable.
- \* Apply the rear brake several times. Each time the brake should release freely without binding or sticking. Rotate the rear wheel assembly to check whether the wheel rotates freely.
- \* Always keep the cables and fittings clean and free of debris. Keeping the cables lubricated will improve service life.

Use the support to prop up the vehicle, and adjust the free travel of the rear brake between  $\frac{1}{4}$ -  $\frac{1}{2}$  inch.



When applying the rear brake, ensure the wheel stops spinning within the recommend free travel. On rear brake cable equipped models, turn the brake adjustment fitting at the bottom of the cable clockwise to tighten the cable and reduce free travel. If you run out of adjustment, please take your vehicle in to an authorized service center for servicing.



### Adjustment of the rear braking light

- \* It is important to always check the vehicle lights and make sure they are properly functioning prior to using the vehicle. The brake light can be inspected with the ignition turned to the on position, and the left and right brake handle compressed.

In order to gain access to the brake switches the left and right-side controls must be removed as well as the brake handles. This can be performed at your local authorized service center.



### Adjustment of the idle speed

If the vehicle stalls out during normal operation due to the engine speed being low, the idle speed can be adjusted:

- \* Before adjusting the idle, make sure the engine has reached normal operating temperature.
- \* Place vehicle on the main stand. While the vehicle is running adjust the idle until the specified RPM is set.

Adjust the idle speed screw here. Turning clockwise will raise the idle; counter clockwise will lower the idle.



**Service and Maintenance for Front and Rear Tires**

Prior to riding always inspect the tires. Make sure the front and rear tire are filled to their recommended pressure. Proper tire inflation increases riding comfort and the stability of the vehicle while prolonging the service life of the tires.

Tire specification/air pressure	Front wheel	120/70-12 32-40PSI
	Rear wheel	120/70-12 32-40PSI



Check the air pressure of the tire and visually inspect the rubber tire and rim for excessive wear or defects. If there are any issues, the tire should be replaced at a local authorized service center.

**Removal and Installation of Front Wheel**

- \* With the engine off, place the vehicle on the center kickstand.
- \* Remove the nut off the front wheel bolt. Slide the bolt out while making sure to retain all hardware including wheel spacers, and speedometer hub.

**Caution:**

- \* Do not use the front brake with the wheel removed.
- \* Check the front brake Master Cylinder fluid level and top off if needed. Verify that the wheel spins freely with no brake drag.

**Warning:**

- \* Always re-torque the front wheel nut to 40-50 ft. lbs.



Failure to properly torque the front wheel nut can lead to serious injury!



## Removal and Replacement of the Rear Wheel

- \* Turn the engine off.
- \* Place vehicle on center stand and remove muffler.
- \* Loosen the rear wheel nut, and remove the rear wheel.

## Installation precautions:

- \* Torque the rear wheel nut to 40-50ft lbs. and reinstall muffler.
- \* Verify the rear brake is adjusted properly.



If the tread depth in the middle of the tire reaches the following limits the tire must be replaced immediately.

Minimum limit of tread depth	Front wheel	2.0mm (0.079")
	Rear wheel	2.0mm (0.079")



Check the tread wear depth of the tires and inspect the sidewalls for damage. If any abnormalities are found, the tire must be replaced immediately.

 **Warning:**

- \* Low tire pressure will increase the rolling resistance of the vehicle, increase fuel consumption, and wear the tire prematurely. In more severe cases it can lead to flat tires. Always check tire pressure prior to riding.
- \* Excessive tire pressure will cause uneven tire wear, increase the risk for blow outs, and decrease vehicle stability.



### Service and Maintenance for the Environmental Protection Device

Vehicle operators must conduct regular service and maintenance of the environmental protection system to ensure the best performance of the assembly. With proper and regular service and maintenance, we can promptly eliminate faults, prolong the service life of the environmental protection system, reduce the maintenance costs, and realize the goal of being environmental-friendly by reducing your vehicles fuel consumption.

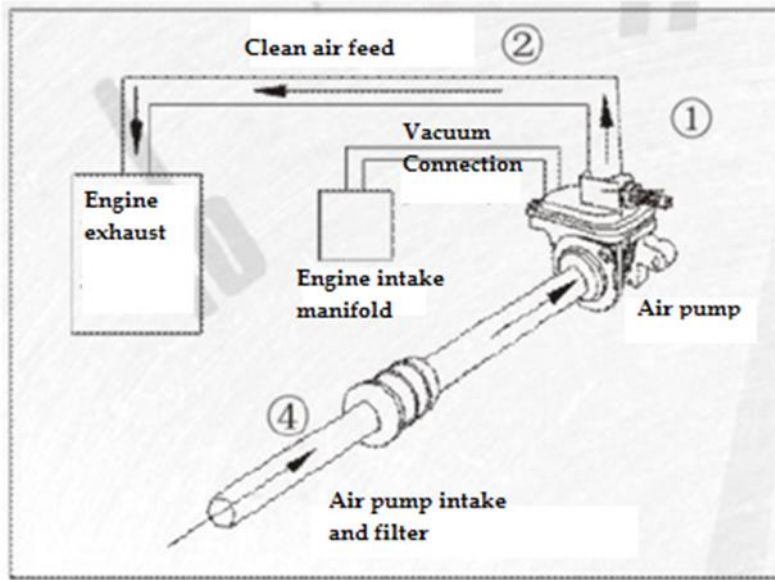

#### **Caution**

The carburetor of the environmental protection device must be serviced and maintained by a professional motorcycle repair shop or the dealer's after-sales service personnel (make sure not to adjust the carburetor without authorization)

- 1 Regularly check whether there is any aging, air leakage or damage on the intake negative pressure hose and the intake plastic hose. If any, replace the intake negative pressure hose and the intake plastic hose.
- 2 Regularly check the working conditions of the air pump of the environmental protection device. If the air pump is blocked or cannot work properly, replace the air pump of the environmental protection device.
- 3 Regularly check the air filter. If any dust or dirt exists on the air filter, the air flow will be reduced, thus changing the concentration of the gas mixture, and increasing fuel consumption. Therefore, it must be changed.
- 4 Regularly check the clamp for the intake vacuum hose, the clamp for the clean air feed, and the mounting bolt for the metal air pump intake pipe. If they are loose, tighten them.

### Service and Maintenance for the battery

In this model, the battery is mounted under the floor mat. For the first 500 to 1000 miles of the vehicle, the battery should be serviced and maintained as follows:

1. Keep the battery poles clean of corrosion.
2. Make sure the positive and negative electrode connections are not loose.
3. If the vehicle is not going to be used for more than 2 weeks, the battery should be disconnected and maintained on a trickle charger.

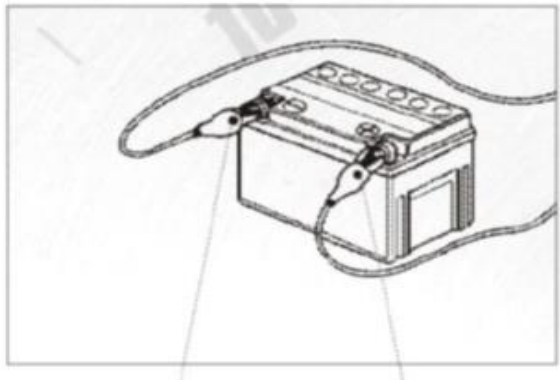

Make sure the positive and negative electrode connections are clean and tight.

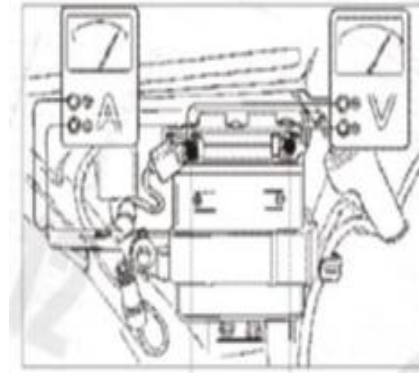

When checking the voltage of the battery, a reading of less than 12 volts is not normal. You should also “load test” the battery to determine if the battery needs to be replaced, or just charged. This can be done at most auto parts stores

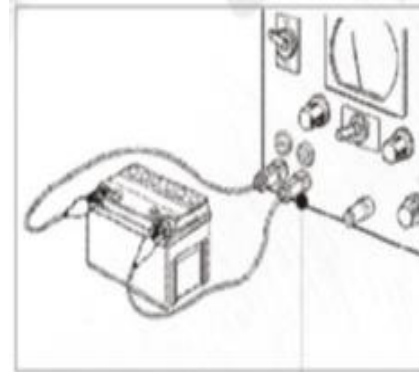

If your battery is showing a voltage level less than 12v, and passes a “load test” place it on a battery charger.

**Service and Maintenance for the Fuse**

The fuse is connected in series to the battery. If there is a sudden power surge or issue within the electrical system, the fuse will automatically break to protect the battery and other electrical components.

**Caution**

\* In the event of a blown fuse, the cause should be found right away as it is indicative that there may be a more serious electrical problem present. In this situation, please bring the vehicle to your authorized WOLF Brand Scooters dealer for service.



If the entire electrical system of the vehicle is not functioning, check the fuse first. A blown fuse will cause all electrical components including the electric start to stop functioning.

**Service and Maintenance for the Horn**

Over time the horn may need to be adjusted. By removing the front panel, you can access the horn and adjustment screw.



If the horn sound becomes weak or isn't working at all, remove the front cover, and use a multi-meter to measure the voltage of the horn circuit. You must do this with the ignition turned on, and it should measure 12 Volts DC. If that is the reading you find, you should then use the adjustment screw in the middle of the horn to get the correct horn sound. If you do not get a read from the multi-meter on the horn circuit, you should have the vehicle checked out by your local WOLF Brand Scooter Dealer.

**Storage of the Vehicle**

For vehicles that will need to be parked for more than one month, the following steps should be taken:

- \* Drain all the fuel from the fuel tank and the carburetor. The Fuel system can be completely drained by running the engine until it stalls after draining the fuel tank. This will not only empty the carburetor of any fuel that might become “stale” but the fuel lines as well.
- \* Remove spark plug. Pour 5mL of clean lubricating oil into the cylinder. Use the kick-starting arm to turn the motor over several times to evenly distribute the lubricating oil throughout the cylinder and combustion chamber. Re-install the spark plug.
- \* Remove the battery, and store it in a dry, dark, and climate controlled environment, also place it on a trickle charger.
- \* Wash the vehicle clean and dry with soft cloth or chamois. Wax the painted surfaces, and apply a film of anti-rust oil to the chrome surface.

- \* Inflate the front and rear tire to the correct P.S.I.
- \* Cover the vehicle, and park it in a well-ventilated, dark dry, clean, place, far away from any hazardous substances such as flammable material or corrosive chemicals.

**Re-use after Storage**

- \* Clean the vehicle. Replace the engine oil if vehicle has been stored for more than 4 months, regardless of mileage.
- \* Check the battery.
- \* Refill the fuel tank with fresh gas.
- \* Perform an inspection on the vehicles brakes, lights, tires, and check for any fluid leaks.

**Service and Maintenance Interval Table**

Service and Maintenance scheduling is based on the vehicles odometer reading If the vehicle is being used in harsh conditions or under heavier than normal loads for long periods of time, the service and maintenance interval should be appropriately shortened.

Service Type		Item	Odometer				Remarks
		Interval	500 Miles	1000 Miles	2000 Miles	3000 Miles	
	Fuel system		C	C	C	C	Items marked ※※ can only be serviced and maintained by authorized Wolf Brand Scooter service center. When driving in an extremely humid or dusty environment, the service and maintenance interval should be appropriately shortened.
	Fuel filter		C	C	C	C	
	Throttle cable		A	A/C	A/C	A/C	
※※	Carburetor		C	C	C	C	
	Air filter		C	C	C	C	
	Spark plug gap		A/C	A/C	A/C	A/C	
※※	Valve lash		A	A	A	A	
	Engine oil		R	R	R	R	
	Oil filter screen		C	C	C	C	
※※	Timing chain		I	A	A	A	
	Carburetor idling		A	A	A	A	
※※	Drive belt		-	A	R	R	
	Battery		B	B	B	B	
	Brake shoe		I	A	A	R	
※※	Braking system		A	A	A	R	
	Brake light switch		A	A	A	A	
	Lighting system		I	I	I	I	
※※	Clutch		I	I	I	I	
※※	Shock absorber		I	I	A	A	
	Nuts and bolts		G	G	G	G	
	Front and rear tire hardware		I	I	I	I	

Service and Maintenance Interval Table for Lubricated Parts

Name	Type	Odometer reading								
		500	1000	2000	4000	8500	10500	15000	20000	
Engine oil	SAE 15W-40 (5W-40 if synthetic)	R	R	R	R	R	R	R	R	
Brake Cables	Multipurpose lithium-based lubricating grease	-	-	R	R	R	R	R	R	
Brake fluid	DOT3 or DOT4	-				R	-			
Lubricating oil for front shock absorber	Lubricating grease for shock absorber	-	I	I	I	I	I	I	I	
Tachometer gear	Multipurpose lithium-based lubricating grease	-			I	R	I	R	I	
Steering gear	Multipurpose lithium-based lubricating grease	-				I	-	R	-	
Bearings for front and rear wheels	Multipurpose lithium-based lubricating grease	-			I	R	I	R	R	
Rear braking swing arm	Multipurpose lithium-based lubricating grease	-				I	-	I	-	

I-Inspection R-Replacement T- Addition

### Trouble shooting common faults

<b>Fault system</b>	<b>Fault</b>	<b>Causes</b>	<b>Troubleshooting</b>
Fuel system	Engine won't start	Fuel not entering the carburetor. The fuel is not flowing from the tank. The vacuum lines are pinched or leak. The fuel line is clogged. The vacuum line is blocked.	Check the fuel lines. Clean the tank and replace fuel shut off valve. Check vacuum lines and replace if needed. Replace fuel lines. Unblock the vacuum lines.
	The vehicle is difficult to start or there is an observable loss of fuel economy	The carburetor is blocked. The air/fuel mixture is not correct. The carburetor leaks. The fuel filter is blocked. The throttle of the carburetor is worn. The fuel is bad. The air vent of the fuel tank is blocked. Low fuel.	Clean or replace the carburetor. Readjust the mixing ratio and concentration of the carburetor. Clean the carburetor or replace the carburetor float. Clean the fuel filter. Replace the throttle. Replace the fuel. Remove blockage in air vent of the fuel tank. Add fuel to the fuel tank.
Air intake/exhaust system	The vehicle is difficult to start.	The Air filter element is blocked. The air filter leaks. The air filter is dirty. The air filter housing leaks. Too much carbon build up at the exhaust port. The exhaust port leaks. The muffler is blocked.	Clean the air filter. Replace the air filter. Clean the air filter. Repair or change the air filter housing. Clean the carbon build up at the exhaust port. Replace the cylinder head. Replace the muffler.

<b>Fault system</b>	<b>Fault</b>	<b>Causes</b>	<b>Troubleshooting</b>
EPA Device	Emitted pollutants exceed applicable standards	Too much carbon is built up at the secondary air intake port. The air pump is blocked or damaged. The air pump filter is blocked or damaged. The intake rubber hose is leaking. The clamp is loose or damaged.	Clean the carbon buildup at the secondary air intake port. Replace the air pump. Replace the air pump filter. Replace the intake rubber hose. Replace the clamp.
Ignition system	Weak spark or no spark	There is carbon buildup on the spark plug. The spark plug gap is not gapped to specs. The insulation part of the spark plug is damaged.	Clean the carbon buildup on the spark plug. Adjust the gap to 0.6mm~0.7mm  Replace the spark plug.
		Short-circuit of the ignition coil C.D.I is faulty.	Replace the ignition coil. Replace C.D.I.
		The stator is faulty. The connection of the ignition system is loose.	Replace the stator. Check each connection.
Engine	The engine is difficult to start and or won't idle.	The cylinder head is leaking. The valves are not adjusted properly. The valves are bent.	Replace the cylinder head. Adjust the valves to .003 inches. Replace the valves.



<b>Fault system</b>	<b>Fault</b>	<b>Causes</b>	<b>Troubleshooting</b>
Engine	Compression ratio is too high.	There is carbon buildup in the combustion chamber and on the top of the piston.	Clean the carbon buildup in the combustion chamber and on the top of the piston.
	Excessive noise coming from engine.	The valves are not adjusted properly. The air valve is broken. The cylinder and piston are worn out.	Re-adjust the valve clearance. Replace the air valve. Replace the damaged internal engine parts.
	The cylinder pressure is too low.	The cylinder, rings, valves, piston could be damaged.	Replace the cylinder, piston, piston rings.
	Excessive smoke from muffler.	The piston ring could be damaged. Oil leaking past the valves. There is wearing on the piston or cylinder wall.	Replace the piston rings. Replace the valve seals. Replace the piston or cylinder.
	The cylinder head leaks.	The valves need to be re-seated.	Re-Dress the valves and valve seats.
Front Wheel	The front wheel vibrates.	The front shock absorber is damaged. The front wheel is damaged. The triple tree is bent. The front wheel is improperly mounted. The front wheel bearings are worn out or damaged.	Replace the front shock absorber. Replace the front wheel. Replace the triple tree. Replace the front tire. Replace the front wheel bearings.
	The front wheel has play in it.	The front wheel is damaged. The front wheel nut is loose. The tire pressure is too low. The front wheel bolt is loose.	Replace the front wheel. Tighten the front wheel nut to specs. Increase the tire pressure. Tighten the front wheel nut to specs.

<b>Fault system</b>	<b>Fault</b>	<b>Causes</b>	<b>Troubleshooting</b>
Rear Wheel	The rear wheel vibrates	The rear wheel is damaged. The tire pressure is too low. The rear wheel nut is loose.	Replace the rear wheel. Increase the tire pressure. Tighten the rear wheel nut to specs.
Suspension system	The shock absorber no longer rebounds	The spring of the shock absorber is worn out.	Replace the spring of the shock absorber.
		The shock absorber is improperly adjusted.	Re-adjust the shock absorber.
Braking system	Poor braking performance	The master cylinder has air in it. The front brake pads are worn out. The brake shoes are worn out. Contaminated or old brake fluid.	Bleed the brake lines. Replace the brake pads or brake shoes. Adjust brake cable. Flush and bleed brake lines.
Lighting system	The head light will not turn on	The head light bulb is burnt out. The headlight switch is faulty. The connecting plug is loose. The fuse is burnt out. The battery is faulty.	Replace the headlight bulb. Inspect headlight switch wires or replace. Check the plug connector. Replace the fuse. Charge or replace battery.
		Stator issues	Check stator connections or replace.

