



recision measuring

www.22cmwonline.com



www.22cmwonline.com

Everyone is permitted to copy and distribute verbatim copies of this document, but changing it is not allowed.

LESSONS : Micrometer Parts

MICROMETER PARTS

A **micrometer caliper** combines the double contact of a slide caliper with a precision screw adjustment which may be read with great accuracy.

Different sized **frames** are available. Frame sizes change in 1 inch increments.

The work is placed against the **anvil** while the spindle is turned down on the work with the thumb.

Work is placed between the **measuring faces**.

The **spindle** advances toward or away from the anvil face and measures work.

The **lock nut** will lock the thimble and measuring rod in place. Tighten lock nut and remove tool from work to read measurement.

The **sleeve** contains the reading line - divided into 40 equal parts. The **.0001 scale** has 10 divisions, further breaking the thimble reading into one-tenth of a division.

One complete revolution of the **thimble** advances the spindle .025 of an inch toward or away from the anvil face.

The purpose of the **ratchet stop** is to ensure that over-tighting does not occur.

www.22cmwonline.com

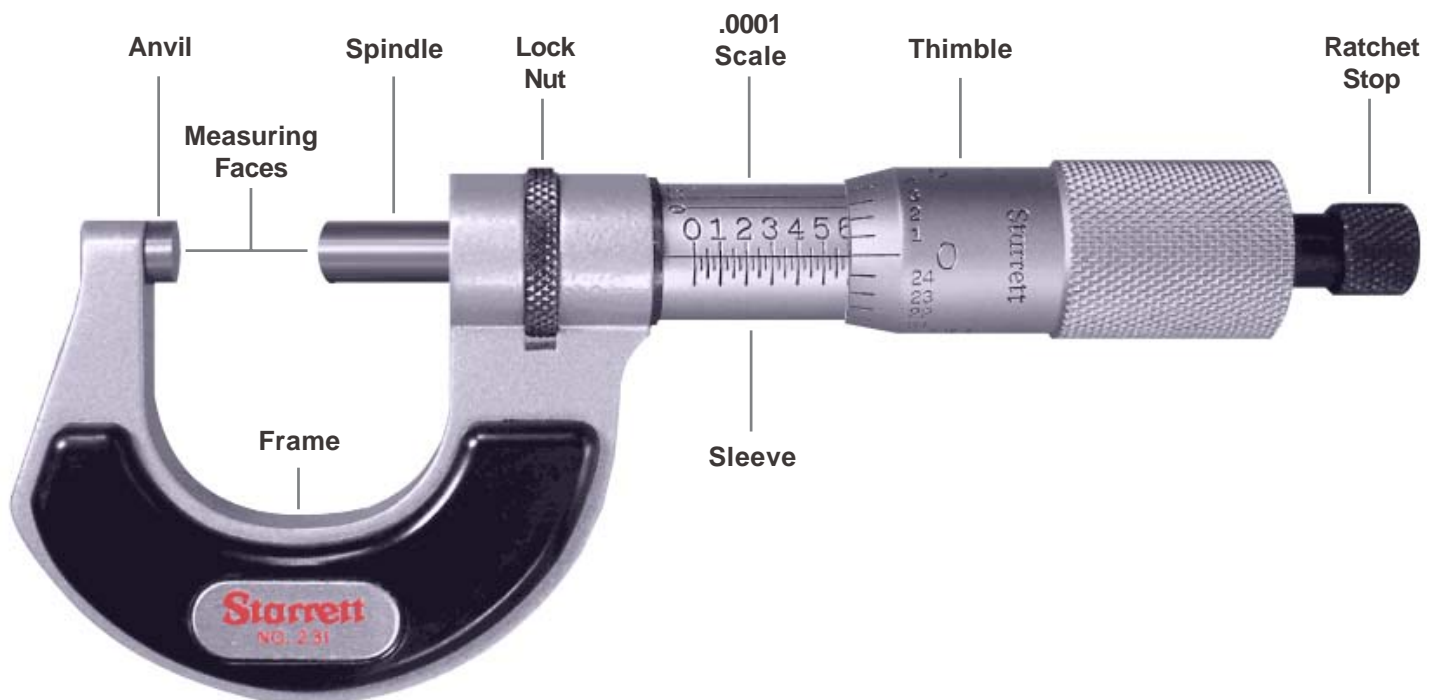

LESSONS : Micrometer Parts

It operates on the principle that a **screw with a pitch of forty threads to the inch** will advance one-fortieth (for .025) of an inch with each complete turn.

As the sectional view illustrates, the **screw threads on the spindle** revolve in a **fixed nut** concealed by the **sleeve**.

Completely removing the thimble will expose **the adjusting nut**. The adjusting nut is the means by which backlash between the spindle thread and fixed nut can be corrected.

*A small tool is provided for this purpose. Caution must be exercised not to over-tighten.

Other internal parts of note are the **Barrel spring**, **Ratchet spring**, **Ratchet plunger**, **Ratchet stop**, and **Ratchet screw**.

On all imperial micrometers, the sleeve is marked longitudinally with 40 lines to the inch spaced 25 thousandths of an inch apart corresponding with the number of threads on the spindle.

The **thimble** includes the **ratchet stop**. The purpose of the ratchet stop is to ensure that over-tightening does not occur.

www.22cmwonline.com

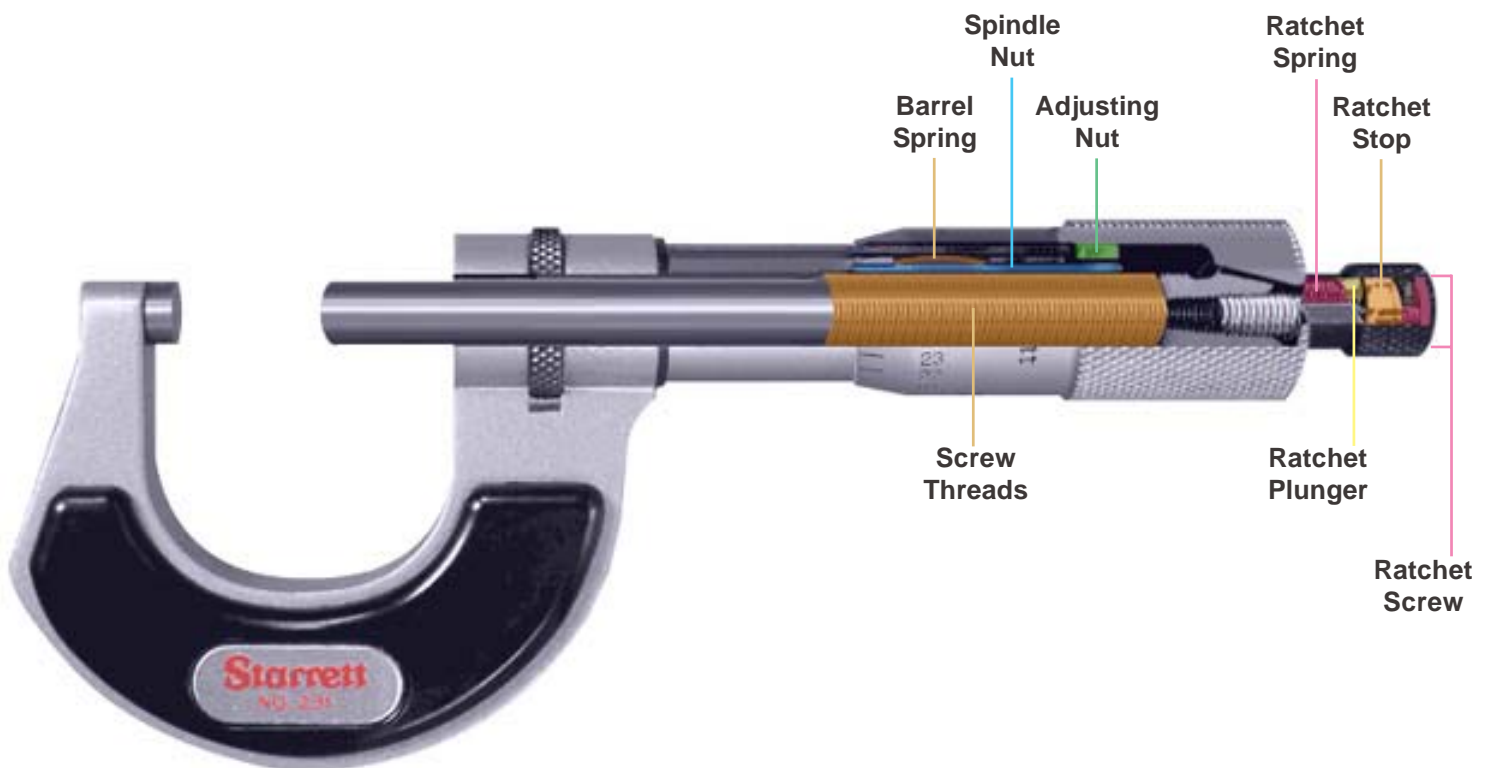

LESSONS : Micrometer Readings

MICROMETER READINGS

To ensure proper reading requires cleaning and calibration of the Micrometer, prior to use.

To adjust zero reading, clean all dirt or grit from measuring faces by gently closing the spindle to the anvil with a clean piece of paper between them. Pull the paper out with pressure applied, then close the faces using "feel" (or Ratchet Stop) and lock the spindle using the Lock nut.

Since the pitch of the screw thread on the spindle is $1/40$ " or 40 threads per inch in micrometers graduated to measure in inches, one complete revolution of the thimble **advances the spindle face toward or away from the anvil face** precisely $1/40$ or .025 of an inch.

Now insert spanner wrench in the small slot of the sleeve. Turn sleeve until its zero line coincides with zero line on thimble.

The reading line on the sleeve is divided into **40 equal parts** by vertical lines that correspond to the number of threads on the spindle. Therefore, **each vertical line** designates $1/40$ or .025 of an inch and every fourth line which is longer than the others designates hundreds of thousandths.

For example: **The line marked "1" represents .100"** of a change between the measuring faces. **The line marked "2" represents .200"** of a change between the measuring faces. **The line marked "3" represents .300"** of a change between the measuring faces etc...



LESSONS : Micrometer Readings

The beveled edge of the thimble is divided into 25 equal parts with each of the graduated lines representing .001" and every line numbered consecutively.

Rotating the thimble from one of these lines to the next **moves the spindle longitudinally** 1/25 of .025" or .001" of an inch; rotating two divisions represents .002" etc. Twenty-five divisions indicate a complete revolution, .025 or 1/40 of an inch.



Example Reading

Measurements are made where the **reading line crosses the spindle.**

The "1" line on the sleeve is visible, representing .100"

There are 3 additional lines visible, each representing .025".

The calculation would be $3 \times .025" = .075"$

Line "3" on the thimble coincides with the reading line on the sleeve, each line representing .001"

The calculation would be $3 \times .001" = .003"$

The micrometer reading is 0.178"

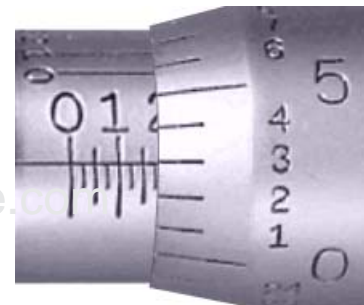

0.100"

3 x .025" = 0.075"

3 x .001" = 0.003"

0.178"

LESSONS : Micrometer Ten-thousandth Scale

MICROMETER TEN-THOUSANDTH SCALE READINGS

If you have mastered the principle of the vernier you will have no trouble reading a **Vernier micrometer** graduated to be accurately read to **one ten-thousandth of an inch**. On a Vernier micrometer, there are **ten divisions marked on the sleeve** occupying the same space as **nine divisions on the beveled edge of the thimble**.



The difference between the width of one of the ten spaces on the sleeve and one of the nine spaces on the thimble is **one-tenth of a division on the thimble**. Since the thimble is graduated to read in thousandths, **one-tenth of a division would be one ten-thousandth of an inch**.

To obtain a reading, **first read to thousandths** as with a regular micrometer **then see which of the horizontal lines on the sleeve is the first to coincide with a line on the thimble**. Always ensure your eye is reading lines while perpendicular to the curved surface of the sleeve to avoid parallax error.

Add to the previous reading **the number of ten-thousandths** indicated by the line on the sleeve **which first coincides with a line on the thimble**.

Example Reading:

The **0** line on the thimble has gone beyond the axial line on the sleeve, indicating a reading of **more than .2500"**.

Checking the Vernier scale on the sleeve shows that the **seventh Vernier line on the sleeve** is the one which **first coincides with a line on the thimble**, therefore, the reading is **.2507"**.

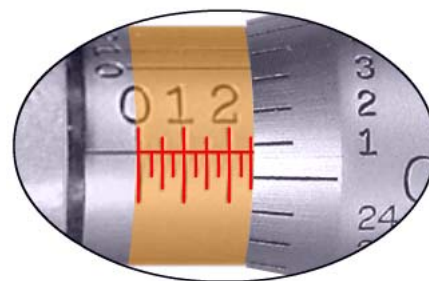

$$\begin{array}{r} .2500'' \\ + .0007'' \\ \hline .2507'' \end{array}$$



Imperial Outside Micrometers Quiz

Record your answer in the following format: .001"



Answer:



Answer:



Answer:



Answer:



Answer:



Imperial Outside Micrometers Quiz

Record your answer in the following format: .001"

6



Answer:

7



Answer:

8



Answer:

9



Answer:

10



Answer:

LESSONS : Metric Micrometer Readings

METRIC MICROMETER READINGS

Since the pitch of the spindle screw is one-half millimeter (0.5 mm), one revolution of the thimble **advances the spindle toward or away from the anvil** the same 0.5 mm distance.

The reading line on the sleeve is graduated in millimeters (1.0 mm) with every fifth millimeter being numbered from 0 to 25.

Each millimeter is also divided in half (0.5 mm), and **it requires two revolutions of the thimble to advance the spindle 1.0 mm.**

The beveled edge of the thimble is graduated in 50 divisions, every fifth line being numbered from 0 to 50.

Since one revolution of the thimble advances or withdraws the spindle 0.5 mm, **each thimble graduation equals 1/50 of 0.5 mm or 0.01mm.** Thus two thimble graduations equal 0.02 mm; three graduations 0.03 mm, etc.

To read the micrometer, add the number of **millimeters and half-millimeters visible on the sleeve** to the number of **hundredths of a millimeter indicated by the thimble graduation** which coincides with the reading line on the sleeve.



LESSONS : Metric Micrometer Readings

Example Reading

The 5 mm sleeve graduation is visible.

One additional 0.5 mm line is visible on the sleeve.

Line 28 on the thimble coincides with the reading line one the sleeve,

The calculation would be $28 \times 0.01 \text{ mm} = 0.28 \text{ mm}$

The micrometer reading is 5.78 mm

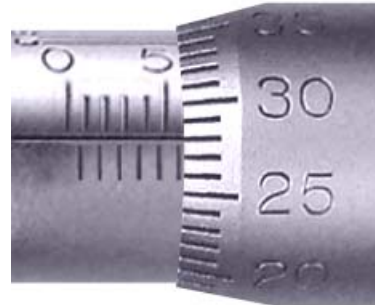

	5.00mm
	0.50mm
$28 \times .01_{\text{mm}} =$	0.28mm
<hr/>	
	5.78mm

www.22cmwonline.com



Metric Outside Micrometers Quiz

Record your answer in the following format: 3.06 mm.

1



Answer:

2



Answer:

3



Answer:

4



Answer:

5



Answer:



Metric Outside Micrometers Quiz

Record your answer in the following format: 3.06 mm.

6

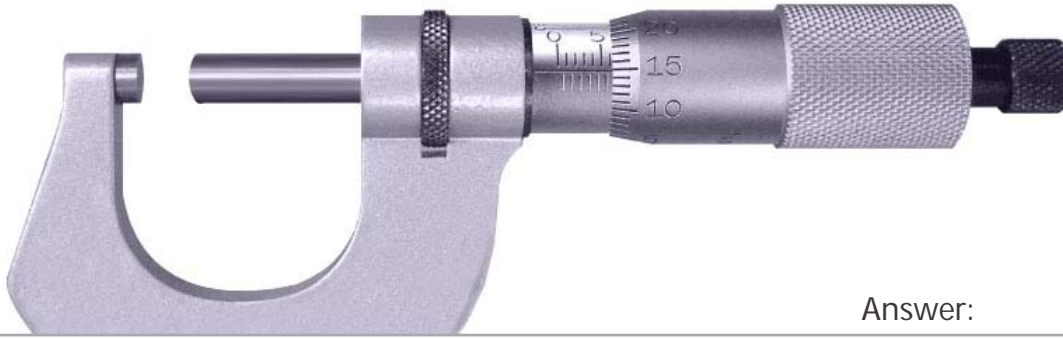

Answer:

7



Answer:

8



Answer:

9



Answer:

10



Answer:

LESSONS : Depth Micrometer Parts

DEPTH MICROMETER PARTS

A **micrometer depth gage**, as the name implies, was designed to measure the depth of holes, slots, recesses, keyways, etc.* Available in both standard or digital readout of imperial or metric measure.

The tool consists of a hardened, ground and lapped **base** combined with a **micrometer head**.

The Micrometer head consists of a **Sleeve, Thimble, Knurled Nut**, and **Ratchet Stop**.

Measuring rods are inserted through a hole in the micrometer screw and brought to a positive seat by a **knurled nut**.* The screw is precision ground and has a one-inch movement. The rods are furnished to measure in increments of one inch. Each rod protrudes through the base and moves as the thimble is rotated.

Adjustment to compensate for wear is provided by an **adjusting nut** at the end of each rod.

Should it become necessary to make an adjustment of a rod,

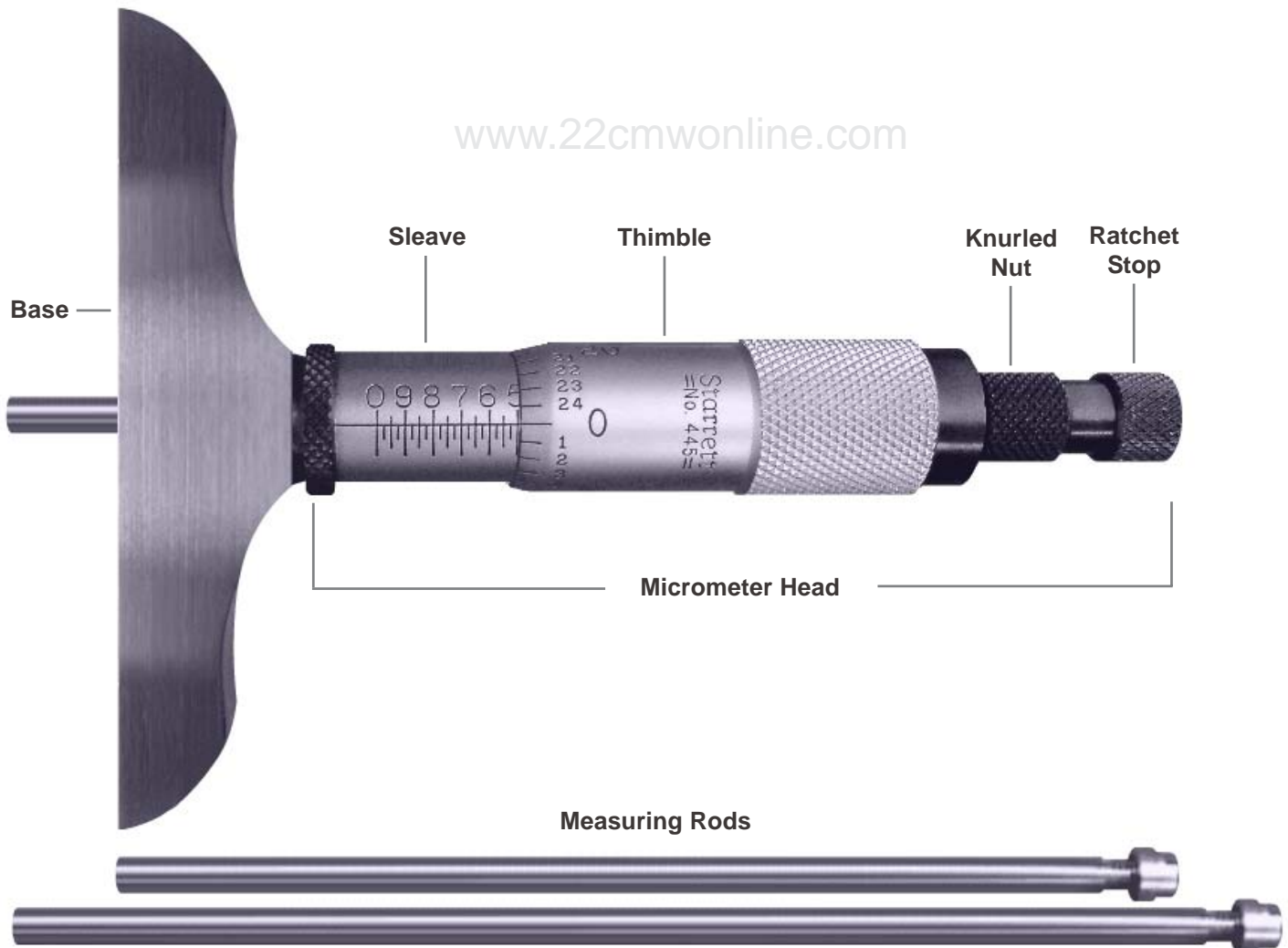

LESSONS : Depth Micrometer Readings

DEPTH MICROMETER READINGS

The reading is taken exactly the same as with an outside micrometer except that the **sleeve graduations run in the opposite direction**.

In obtaining a reading using a rod other than the **0-1"**, it is necessary to **consider the additional rod length**.

For example, if the **1-2" rod** is being used, **one inch must be added** to the reading on the sleeve and thimble. When using the **2-3" rod**, **two inches must be added** to the reading, and so on.

Example Reading

The "4" line on the sleeve is covered, representing **.400"**

There are 3 additional lines covered, each representing **.025"**

The calculation would be **3 x .025" = .075"**

Line "3" on the thimble coincides with the reading line on the sleeve, each line representing **.001"**The calculation would be

3 x .001" = .003"

The depth micrometer reading is 0.478"

METRIC DEPTH MICROMETER READINGS

The reading is taken exactly the same as with an outside micrometer except that the **sleeve and thimble graduations run in the opposite direction**, and that the readings are derived by adding the 1 mm and .5 mm lines covered by the thimble to the .01 lines past the reading line on the thimble

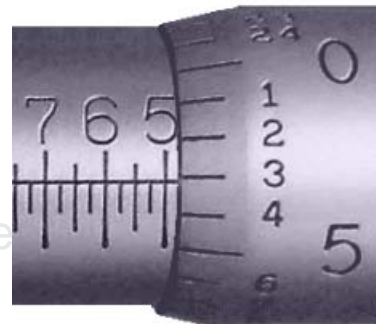

0.400"

3 x .025" = 0.075"

3 x .001" = 0.003"

0.478"





Imperial Depth Micrometers Quiz

Record your answer in the following format: 3.06 mm.



Answer:



Answer:



Answer:



Answer:

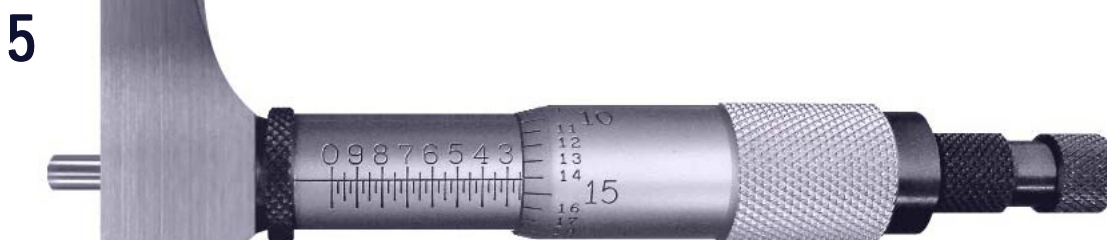

Answer:



Imperial Depth Micrometers Quiz

Record your answer in the following format: 3.06 mm.

6



Answer: _____

7



Answer: _____

8



Answer: _____

9



Answer: _____

10



Answer: _____



Metric Depth Micrometers Quiz

Enter the reading shown on this micrometer to the nearest .01 Millimeter increment.

1



Answer:

2



Answer:

3



Answer:

4



Answer:

5

Answer:



Metric Depth Micrometers Quiz

Enter the reading shown on this micrometer to the nearest .01 Millimeter increment.

6



Answer: _____

7



Answer: _____

8



Answer: _____

10



Answer: _____

LESSONS : Inside Micrometer Parts

INSIDE MICROMETER PARTS

Inside micrometers are an application of the micrometer screw principle to adjustable-end measuring gages. Note: The reading scale is identical to a micrometer. To learn how to read a micrometer see lessons - Micrometer Readings

The distance between ends or contacts is changed by **rotating the thimble** on the micrometer head up to the extent of screw length, usually **either one-half or one inch**.

Greater distances are obtained by means of **extension rods** and suitable **spacing collars** or gages which slide onto the holding end of the interchangeable rods in various combinations to cover the total range of the tool.

Inside micrometers are a little more difficult to use than outside micrometer calipers. With **spherical contact**

points more practice and caution is needed to "feel" the full diametral measurement.

Since one contact point is generally held in a fixed position, the other must be **rocked in different directions** to be sure the tool is spanning the true diameter of a hole or the correct width of a slot.

In place of a locknut, a **friction drag** is noticeable on the thimble.

Measuring rods can be individually **adjusted to take up wear**, and the micrometer head is also **adjustable for wear on its screw**.

A **knurled extension handle** is available for obtaining inside measurements in hard-to-reach locations.

