

PRODUCT CATALOG



TRICO
MAXIMIZE, OPTIMIZE, NEVER COMPROMISE.™



Table of Contents

Introduction to Trico A1

Flexible Flinger Disc B1

Constant Level Lubrication C1

- Opto-Matic® Constant Level Oilers C2-C3
- Breather Tubes C4
- LCL Oilers C5
- Opto-Matic® Closed System Oilers C6
- Watchdog® Oilers C7

Pressure Differential Products D1

- Equalizer™ Expansion Chambers D2
- Selection of an Expansion Chamber D3

Visual Inspection Units E1

- Sump Bottles E2
- Liquid Level Gauges E3-E4

Oil Sampling/Analysis F1

- Oil Sampling Ports F2-F3
- Pitot Tube Sampling Ports F4
- Liquid Level Gauge Sample Ports F5
- Spacer Flange Sampling Ports F6
- Catch Pipe Sampling Ports F7
- Vacuum Pump and Sampling Accessories F8
- Reservoir Breather Kits F9-F10

Moisture Detection & Removal G1

- Hydrolert® Products G2
- Watchdog® Desiccant Breathers G3-G4
- Watchdog® EX Series Breathers G5
- Watchdog® Breather Adapters G6
- Watchdog® Oil Dryer G7

Portable Filtration Systems H1

Fluid Handling Systems I1

- Oil Safe® Products I2-I3

Gravity Feed Oilers J1

- Gravity Feed Oilers J2
- Atlas Gravity Feed Oilers J3
- PC Oil Cup J4
- Vari-Feed Wick Oilers J5
- CA & CAE Chain Oilers J6
- CB & CBE Chain Oilers J7

- CC & CCE Chain Oilers J8
- D & DE Full Flow Dispensers J9
- E & EE Multiple Feed Oilers J10
- V Series Valves & VM Manifolds J11
- ST Series Valves / S Series Applicators J12
- Applicators J13

Grease Lubrication K1

- Streamliner™ Grease Dispensers K2-K4

Central Lubrication L1

- Basic Types of Systems L2
- Positive Displacement Injectors L3
- Pumps for PDI Systems L4
- PM-10 & 20 Series Manual Cyclic Pumps L5
- PE-10 & 12 Series Automatic Cyclic Pumps L6
- PE-20, 22 & 24 Series Automatic Cyclic Pumps L7
- PE-30 & PE-32 Series Automatic Cyclic Pumps L8
- PE-40 & PE-50 Series Continuous System Pumps L9
- Meter & Control Units L10
- Fittings L11-L12
- Fittings & Hoses L13
- Accessories L14
- Technical Information L15
- Using the System Design Worksheet L16-L17
- System Design Worksheet L18
- Product Selection Charts L19
- Distribution Network Design L20-L21

Minimum Quantity Lubrication M1

- MD-1200 Micro-Drop® M2-M3

Spray Cooling N1

- DL & DL Magnum N2
- Li'l Mister® Systems N3
- "SST" Spray Coolant Systems N4
- Spraymaster® N5
- Spraymaster® II N6
- Type "B" Spray Coolant Systems N7
- Mistmatic® Coolant Delivery Systems N8
- Coolant Delivery Systems N9-N10

Lubricants & Coolants O1

- Tri-Cool® Fluids O2-O3

◆ In the selection charts on the following pages, units with inch threads are indicated with red model numbers, and metric units with green model numbers.

TRICO CUSTOMER SATISFACTION GUARANTEE

Trico is proud of its commitment to quality. All Trico products are guaranteed against defects in workmanship and materials for as long as you own them. Under this guarantee, free repair or replacement will be made at our discretion. Normal wear and tear or misuse is not covered under this warranty. For prompt service, contact Trico Customer Service at 800-558-7008 or your local authorized distributor.

Trico reserves the right to change product specifications without prior notice.



1235 Hickory Street, Pewaukee, WI 53072
Tel. 1-800-558-7008 or 262-691-9336 FAX 262-691-2576
www.tricocorp.com

Cat. No. 60007 03/06
©Copyright Trico Mfg. Corp. 2006

Trico.

Total Lubrication Management Solutions.

Total Solutions. That's what Trico is all about.

We're your complete resource for the lubrication management products and services you need to keep your machines running productively—around the clock.

Whether you're looking for an assessment of your lubrication maintenance procedures, an audit of your entire facility, training for employees or simply the most complete line of high-performance lubrication management products in the country—Trico has your solution.

For more than 89 years, Trico has provided clients with a focus on industrial equipment performance and reliability. We've done this by combining high-performance lubrication products, with our nationally-recognized proactive lubrication management training, auditing and consulting programs.

SERVICES

- Consulting
- Monitoring
- Training
- Auditing

PRODUCTS

- Constant Level Lubrication
- Desiccant Breathers
- Oil Sampling/Analysis
- Moisture Detection Systems
- Fluid Handling Systems
- Gravity Feed Oilers
- Grease Lubrication
- Central Lubrication
- Gear Oil Filter Carts
- Spray Cooling and Minimum Quantity Lubrication

Total solutions from Trico. It's about maximizing your machine productivity and optimizing your operations without ever compromising your standards so you get the productivity you're looking for and the reliability you need.

MAXIMIZE, OPTIMIZE, NEVER COMPROMISE. It's our way of doing business.



Flexible Flinger Disc

The Flexible Flinger Disc represents a philosophical change in some lubrication fundamentals. The disc is designed to throw oil around inside the bearing housing from an oil bath residing below the traditional bearing oil level. This is predominantly found in API standard pump configurations where slinger rings have been commonplace. It is intended to create an "oil splash", similar to slinger rings, to ultimately provide better lubrication to the bearings without the inherent disadvantages associated with other methods, including slippage, metal wear, ring travel, and misapplication.

FEATURES:

- Firmly fixed to shaft eliminating metallic particle wear found in slinger ring applications
- Eliminates slippage common to slinger rings
- Not sensitive to shaft horizontality, oil viscosity, or high oil immersion
- Easy assembly and disassembly through bearing housing with flexible Viton® material
- Corrosion resistant stainless steel hub
- Minimum stocking requirements due to the ability to machine hub to fit various shaft diameters and the trimmable outer diameter to meet specific application requirements

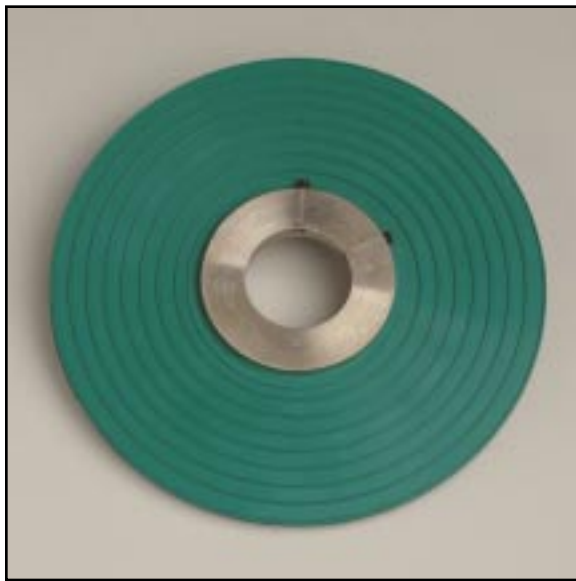

SPECIFICATIONS

Max. Operating Temp.	350° Continuous
Hub Material	Stainless Steel
Flinger Material	Viton®
Shaft Connection	(2) 10-32 Set Screws
Outside Diameter	3.50" - 7.00" 5.00" - 9.50"
Inside Diameter	1.50" - 2.50" 2.50" - 4.00"

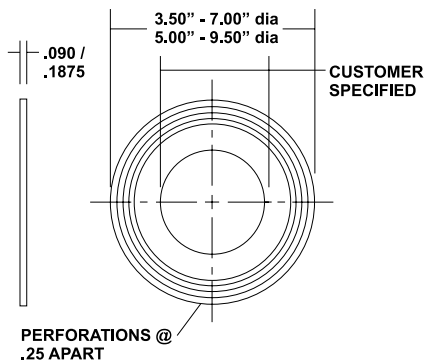

SELECTION CHART

Model No.	Inside Diameter	Outside Diameter
36950	1.50" to 2.50"/Machined by Customer	3.50" to 7.00"
36951	1.50" to 2.50"/Customer Specified	3.50" to 7.00"
36952	2.50" to 4.00"/Machined by Customer	5.00" to 9.50"
36953	2.50" to 4.00"/Customer Specified	5.00" to 9.50"

Introduction to Constant Level Lubrication

Constant level oilers are designed to maintain a predetermined oil level in a sump, which is necessary for proper lubrication. If the oil level were to drop below this point, the depleted oil would automatically be replenished by the lubricator, returning it to its original level. With the use of constant level oilers, maintenance efficiencies can be increased, while minimizing maintenance costs, and the loss of production time.

The majority of constant level oilers available are adjustable, allowing for use in many applications. However, there are oilers available that do not allow for fluid level adjustability, eliminating potential installation errors. Typically, constant level oilers are mounted on the side of the equipment facing the direction of shaft rotation. Some oilers allow for bottom mounting, on the oil sump, which prevents the oiler from misfeeding during applications that contain currents and turbulence formed by slinger rings, discs, and high rotating speeds.

In most cases constant level oilers are vented to the outside atmosphere to work properly. Since these oilers are vented to the atmosphere, especially in harsh, dirty environments, contaminants are allowed to enter the lubricating oil. These contaminants are in the forms of moisture and/or particulate which are extremely damaging to oil and equipment life.

In order to combat the potential for oil contamination, the closed system oiler was developed. These oilers are effective in minimizing and eliminating the ingress of contaminants into the oil sump, especially in dirty environments. Some closed system oilers contain a pressure balancing line, which is connected from the headspace of the oil sump to an air chamber built into the surge body of the oiler. This air chamber is sealed from the outside atmosphere in order to prevent the ingress of contaminants. Additional types of closed system oilers are available that mount directly on the centerline of the oil level to be maintained. The exchange of air between the oil sump and the oiler is at the oiler's base, which is mounted directly to the oil sump.

Several different types of constant level oilers are available to meet specific application needs, whether it is vented or non-vented, adjustable or nonadjustable they are an easy and effective method of maintaining proper oil level in equipment.

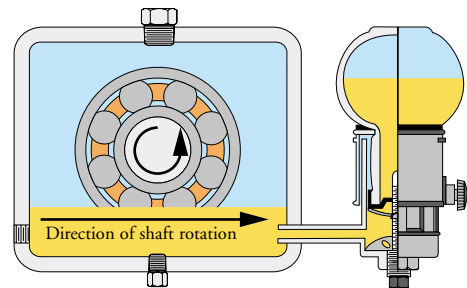

VENTED CONSTANT LEVEL OILER WITH SIDE CONNECTION

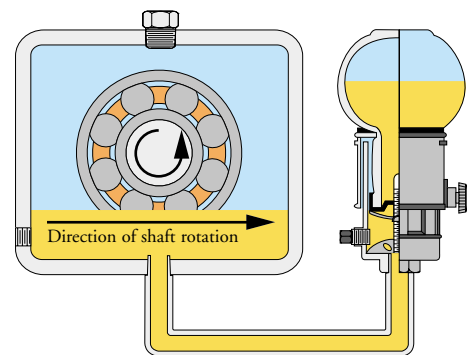

VENTED CONSTANT LEVEL OILER WITH BOTTOM CONNECTION

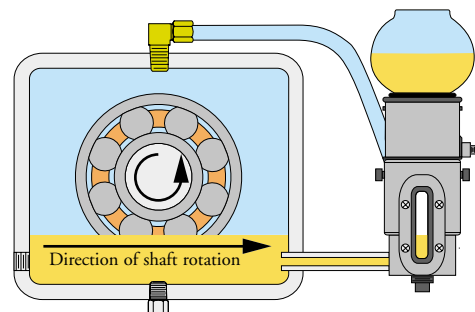

CLOSED SYSTEM OILER WITH PRESSURE BALANCING LINE

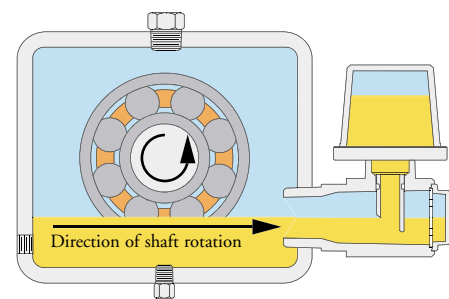

CLOSED SYSTEM OILER MOUNTED ON CENTER LINE OF DESIRED OIL LEVEL



Opto-Matic® Constant Level Oilers



APPLICATIONS:

Opto-Matic oilers provide an inexpensive method to automatically maintain a constant level of oil in a pump bearing housing, gear box, or other oil sump applications. Throughout processing industries, the Opto-Matic oiler is the industry standard. Different reservoir capacities allow use in many applications.

Stainless steel models provide long life in corrosive environments in the chemical, pulp and paper, and mining industries.

FEATURES:

- One piece glass reservoir ensures proper constant level function. Compared to competitive models, there is no possibility of air leakage that would cause overfilling of the bearing housing.
- Adjustable level setting allows use in many applications.
- Multiple air vent slots provide for proper functioning at all times.
- Large surge chamber helps prevent overflow of oil during machine start-up or shut-down.
- Side and bottom connections for simplified installation.

Wire Guards

Wire guards are ordered separately and are customer installed.

Model No. Standard	Model No. Stainless Steel	Description
30012	-	2-1/2 oz. Guard
30013	30223	4 oz. Guard
30016	30225	8 oz. Guard
30020	30230	16 oz. Guard

SPECIFICATIONS

	Standard	304 Stainless Steel
Max. Operating Temp.	250°F Continuous	
Reservoir	One-Piece Glass Bottle	
Casting	Zinc	304 Stainless
Finish	Zinc/Chromate Plate	Passivated
Internal Parts	Zinc Plated Steel	
O-Ring	Viton®	

Viton® is a registered trademark of Du Pont Dow Elastomers.

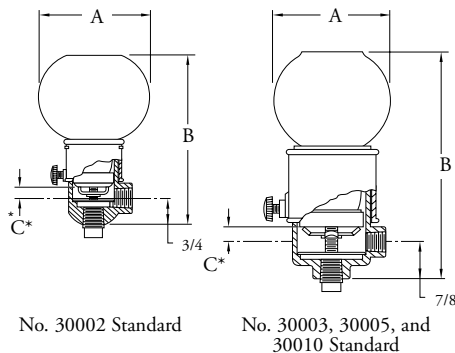

No. 30002 Standard

No. 30003, 30005, and 30010 Standard

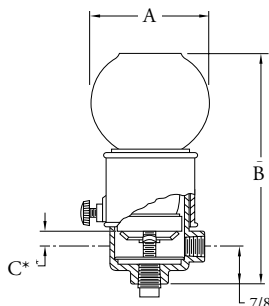

Connection Side and Bottom
Stainless Steel

* "C" dimensions represent oil level range

SELECTION CHART- STANDARD

Model No.	Capacity	Connection (NPT)*	Dimensions (in.)				
			A	B Min.	B Max.	C Min.	C Max.
30002	2-1/2 oz.	1/4	2-1/2	3-15/16	4-1/4	11/32	9/16
30003	4 oz.	1/4	2-11/16	5	5-3/4	9/32	1
30005	8 oz.	1/4	3-3/16	5-15/16	6-11/16	9/32	1
30010	16 oz.	1/4	4-1/8	6-13/16	7-9/16	9/32	1

* Metric thread sizes available. Add "-M" to part number for 1/4 BSPT connection port.

SELECTION CHART - STAINLESS STEEL

Model No. With Side & Bottom Connect	Capacity	Connection (NPT)*	Dimensions (in.)				
			A	B Min.	B Max.	C Min.	C Max.
30213	4 oz.	1/4	2-11/16	4-15/16	5-11/16	9/32	1
30215	8 oz.	1/4	3-3/16	5-7/8	6-5/8	9/32	1
30220	16 oz.	1/4	4-1/8	6-3/4	7-1/2	9/32	1

* Metric thread sizes available. Add "-M" to part number for 1/4 BSPT connection port.

Opto-Matic® Constant Level Oilers

APPLICATIONS:

Opto-Matic oilers provide a constant level of oil in a pump bearing housing, gear box, or other oil sump applications. Different reservoir capacities allow use in many applications.

“LS”, “EH”, and “EHB” models have a large surge chamber to minimize potential of leakage during oil surge conditions.

FEATURES:

- High strength, transparent, ribbed plastic reservoir provides long life and impact resistance.
- Adjustable level setting allows use in many applications.
- Multiple air vent slots provide for proper functioning at all times.
- Large surge chamber (LS, EH, and EHB models) prevents overflow of oil during machine start-up or shut-down.
- Side and bottom connections for simplified installation.



SPECIFICATIONS

Max. Operating Temp.	165°F Continuous
Reservoir	Butyrate Plastic
Casting	Zinc Die Cast
Finish	Bright Zinc Plated
Internal Parts	Zinc Plated Steel

SELECTION CHART - E, EB

Model No.		Capacity	Connection (NPT)*	Dimensions (in.)				
E	EB			A	B Min.	B Max.	C Min.	C Max.
30052	30062	2 oz.	1/4	1-15/16	3-7/8	4-3/8	1/4	3/4
30054	30064	4 oz.	1/4	2-5/16	4-9/16	5-1/16	1/4	3/4
30058	30068	8 oz.	1/4	2-5/8	5-11/16	6-3/16	1/4	3/4

* Metric thread sizes available. Add “-M” to part number for 1/4 BSPT connection port.

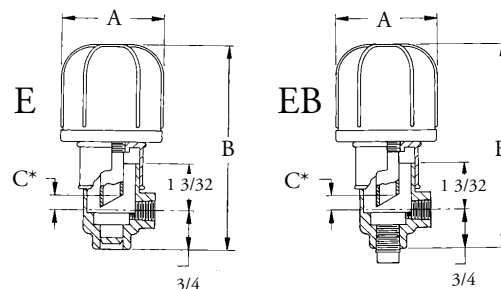

SELECTION CHART - EH, EHB (large surge chamber)

Model No.		Capacity	Connection (NPT)*	Dimensions (in.)				
EH	EHB			A	B Min.	B Max.	C Min.	C Max.
30072	30082	2 oz.	1/4	1-15/16	5	5-1/2	1/4	3/4
30074	30084	4 oz.	1/4	2-5/16	5-11/16	6-3/16	1/4	3/4
30078	30088	8 oz.	1/4	2-5/8	6-13/16	7-5/16	1/4	3/4

* Metric thread sizes available. Add “-M” to part number for 1/4 BSPT connection port.

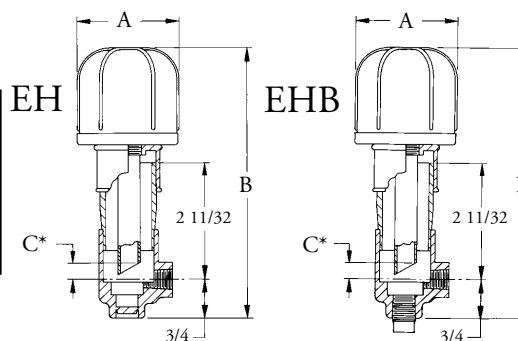

SELECTION CHART - LS (large surge chamber)

Model No.	Capacity	Connection (NPT)*	Dimensions (in.)				
			A	B Min.	B Max.	C Min.	C Max.
30024	4 oz.	1/4	2-5/16	5-7/16	6-3/16	9/32	1
30028	8 oz.	1/4	2-5/8	6-9/16	7-5/16	9/32	1

* Metric thread sizes available. Add “-M” to part number for 1/4 BSPT connection port.

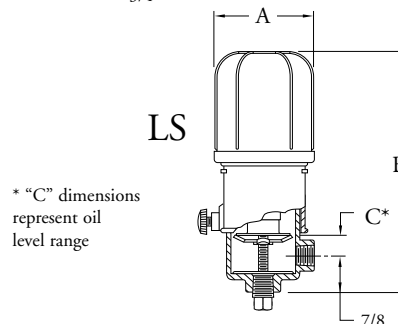

* “C” dimensions represent oil level range

Breather Tubes

Breather tubes are accessories used in conjunction with vented Opto-Matic Oilers to help eliminate vacuums created by abnormally tight bearings or pressures created by high speed bearings. The breather tube helps maintain a constant atmospheric pressure in the bearing housing.

SELECTION CHART

Model No.	Description	
30014	Type "C"	1/8 NPT Thread Wick Filter
30015	Type "E"	1/8 NPT Thread Dust Cap

Breather tubes are available for customer installed vent ports in bearing housing or piping lines.

Helpful Tip:

Breather tubes are ideal for use in environments that contain minimal contaminants. If contamination is a concern the WATCHDOG Desiccant Breathers are an excellent choice for removing contaminants as well as allowing the equipment to breathe.



30015



30014

LCL Oilers

APPLICATIONS:

LCL large capacity oilers provide a constant level of oil in a pump bearing housing, gear box, or other oil sump applications. They operate on the same principle as the Opto-Matic® oilers and are used in applications requiring a large reservoir capacity.

In isolated areas where refilling is a problem, LCL oilers can save time and maintenance costs.



FEATURES:

- Large capacity glass or acrylic reservoir to 2-1/2 quarts, acrylic reservoir available in 1 gallon.
- Factory set oil level at center line of side outlet allows easy installation.
- Specially designed feed tube to ensure reliable lubricant delivery.
- Large surge chamber prevents overflow of oil during machine start-up or shut-down.
- Side connection of 1/2 NPT makes for durable and rigid installation. Mounting bolt (1/4-20) provided for attachment to support bracket.

SPECIFICATIONS

Max. Operating Temp.	Glass 250°F Continuous Acrylic 165°F Continuous
Reservoir	Heavy Wall Heat Resistant Glass Heavy Wall Acrylic Plastic
Gasket	Buna-N
Materials	Brass
Casting	Aluminum Sand Casting
Finish	Lacquered Satin Finish

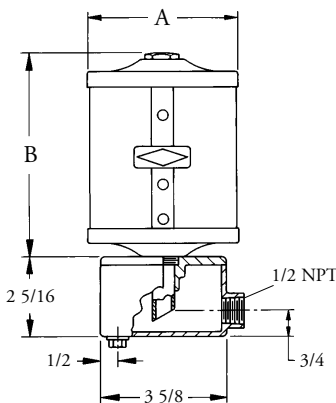

SELECTION CHART

Model No.		Capacity	Mounting Bolt	Dimensions (in.)	
Glass	Acrylic			A	B
32511	32410	10 oz.	1/4-20	3-1/8	4-1/4
32517	32416	1 pt.	1/4-20	3-5/8	5-5/16
32533	32432	1 qt.	1/4-20	4-7/16	6-3/8
32581	32480	2.5 qt.	1/4-20	5-11/16	9-1/2
-	32481	1 gal.	1/4-20	5-11/16	14-1/2

Helpful Tip:

The LCL oiler is a vented oiler that mounts on the centerline of the desired oil level.

Opto-Matic® Closed System Oilers

APPLICATIONS:

The Opto-Matic closed system oiler is designed for all types of equipment where a constant level in an oil sump must be maintained. The closed system design prevents contamination and spillage. The adjustable collar allows the oil level to be externally adjusted to the desired level. A 1/8 NPT port is provided for a vent line back to the housing to allow pressure balancing between the oiler and the housing.

FEATURES:

- One piece glass reservoir ensures proper constant level function. Compared to competitive models, there is no possibility of air leakage that would cause overfilling of the housing.
- Adjustable level setting allows use in many applications.
- Bottom of adjusting collar indicates actual oil level setting for easy set-up and maintenance.
- Side and bottom connections for simplified installation.
- 2" sight gauge for easy viewing of oil level.



SELECTION CHART

Model No.	Capacity	Dimensions (in.)			
		A	B Min.	B Max.	NPT*
30203	4 oz.	2-11/16	7-1/16	7-13/16	1/4
30205	8 oz.	3-3/16	8	8-3/4	1/4
30210	16 oz.	4-1/8	8-7/8	9-5/8	1/4

*Metric thread sizes available. Add "-m" to part number for 1/4 BSPT connection port

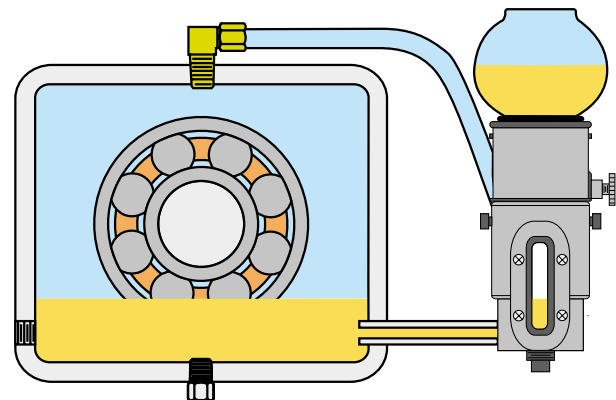

OPTO-MATIC CLOSED SYSTEM OILER
WITH PRESSURE BALANCING LINE

SPECIFICATIONS

Max. Operating Temp.	250°F Continuous
Reservoir	One-Piece Glass Bottle
Upper Casting	Zinc
Lower Body	Zinc
Adjusting Collar	Zinc
O-Ring	Viton®

Wire Guards

Wire guards are ordered separately and are customer installed.

Model No.	Description
30013	4 oz. Guard
30016	8 oz. Guard
30020	16 oz. Guard

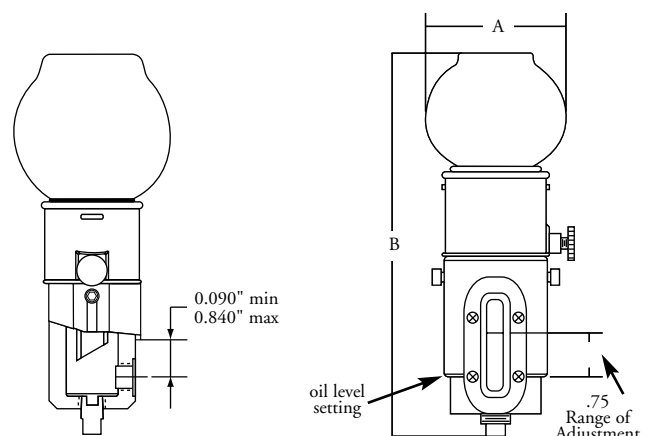

Watchdog® Oilers

The WATCHDOG closed system oiler is designed for bearing housings, gear boxes, and other oil sump applications. It is ideal for use in the chemical processing, power generation, pulp and paper, and utility industries. The viewport provides visual indication of lubricant level and condition. Mounted on the centerline of the desired oil level, these constant level oilers do not require any adjustment or level setting.



FEATURES:

- Closed system design prevents contamination and spillage.
- No vent line to pump bearing housing required, simplifying installation.
- 2 oz. or 4 oz. reservoirs provide oil make-up.
- Mounts on centerline of desired oil level, and does not require adjustment or level setting.
- Integral viewport eliminates need for additional component.

SPECIFICATIONS

	Aluminum Body	Thermoplastic Body	Stainless Steel Body
Body	Cast Aluminum	Polysulfone	Stainless Steel
Reservoir	Glass or Polysulfone	Polysulfone	Glass
Viewport	Glass or Polysulfone	Polysulfone	Glass
Max. Operating Temp.	325°F/160°C	325°F/160°C	325°F/160°C
O-Ring	Viton®	Viton®	Viton®

SELECTION CHART

Model No.	Style	Capacity	Connection	Wire Guard	Dimensions (in.)		
					A	B	C
31802	Thermoplastic Body, Reservoir and Viewport	2 oz.	1 NPT	No	4-1/32	3-9/32	1
31804		4 oz.		No	5-3/4	3-9/32	1
31818	Aluminum Body, Glass Reservoir and Viewport	4 oz.	1/2 NPT	No	6-1/4	4-1/8	1/2
31820		4 oz.	3/4 NPT	No	6-1/4	3-1/4	3/4
31821		4 oz.	1 NPT	No	6-1/4	3-1/4	1
31822		4 oz.	3/4 BSPT	No	6-1/4	4-1/8	3/4
31823		4 oz.	1 BSPT	No	6-1/4	3-1/4	1
31824		4 oz.	3/4 NPT	Yes	6-1/2	3-3/8	3/4
31825		4 oz.	1 NPT	Yes	6-1/2	3-3/8	1
31826		4 oz.	3/4 BSPT	Yes	6-1/2	4-1/8	3/4
31827		4 oz.	1 BSPT	Yes	6-1/2	3-3/8	1
31828		4 oz.	1/2 NPT	Yes	6-1/2	4-1/8	1/2
31829	Stainless Steel Body, Glass Reservoir and Viewport	4 oz.	1 NPT	No	6-1/4	3-1/4	1

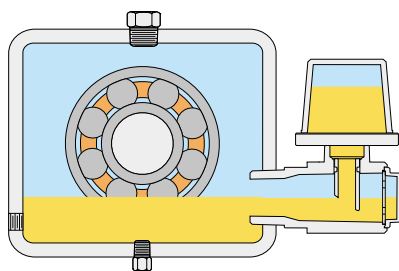

WATCHDOG Oiler mounted on centerline of desired oil level.

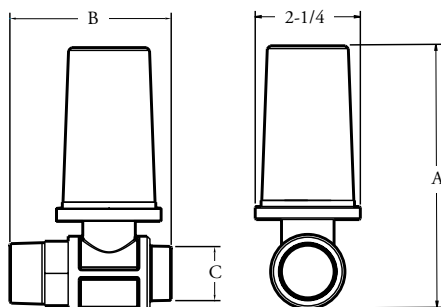

Introduction to Pressure Differential Products

Frequent operation start-ups and environmental temperature swings in mechanical equipment can cause the air pressure inside oil sumps to increase and decrease, causing it to ‘breathe’. This “breathing” air, in most cases, comes from the external atmosphere through vents, fill ports, seals, and anywhere the oil sump is open to atmosphere. This can cause debris, dirt, and moisture to enter the equipment attacking and breaking down the equipments vital lubricant and ultimately reducing the life of bearings and gears. The EQUALIZER® Expansion Chamber reduces or eliminates this “breathing” action by replacing the vent, providing an extra 25 cubic inches of airspace, by a rolling diaphragm. This provides the extra air volume necessary to overcome expansion and retracting inside the housing, eliminating the need for equipment to “breathe” contaminated and damaging external air. But, just how much of this “breathing” occurs? Below is a typical installation of a common piece of equipment and the effects of temperature fluctuations.

Using the following volume and temperature parameters, these values can be inputed into the plug-in worksheet supplied at www.tricomfg.com/size-expand-worksheet.asp, or follow the **Selection of an Expansion Chamber** worksheet supplied on the following page. As shown here, a relatively common occurrence can produce up to almost 18 in³ of air expansion which escapes through the seals or vents. Conversely, that 18 in³ needs to return to the housing when temperatures cool. That is when the damage is done.

Closing your system is the most effective way to eliminate harmful contaminants from entering your system and the EQUALIZER® Expansion Chamber supplies the added air volume to eliminate the need for breathing due to temperature fluctuations. This is especially important when used in harsh or contaminated environments and when frequent start-up and shut-downs are necessary.



Amount of Oil in Housing (oz.)		32
Temp. Range of Housing (F)	High	110
	Low	60
Total Volume in Housing (oz.)		128
Total Expansion: 17.81 cubic inches		

Equalizer™ Expansion Chambers

APPLICATIONS:

Equalizer Expansion Chambers are designed to prevent pressure increase in closed systems. A rolling diaphragm provides a variable volume, that when properly sized, maintains oil housing pressure at or near zero PSI. The reduced pressure will extend seal life and help prevent leakage. Expansion chambers also protect the integrity of closed systems by preventing the exchange of air from the chamber to the surrounding atmosphere. A choice of thread sizes offers flexibility to the user.

FEATURES:

- Made from corrosion resistant stainless steel.
- Controlled housing pressure extends seal life.
- Prevents contamination ingress to help lubricants stay cleaner for longer life and improved performance.
- Full 25 cubic inch air expansion capability
- Maintenance free operation

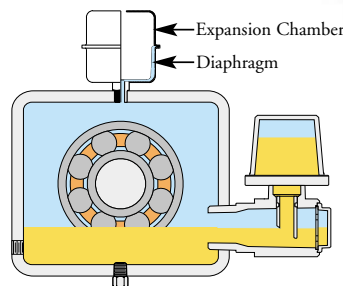

Expansion chamber at normal temperature.

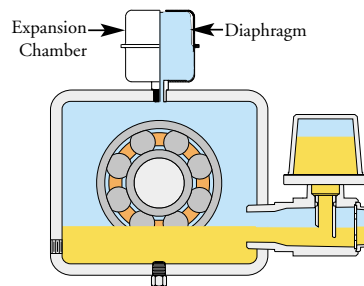

Expansion chamber at higher temperature.

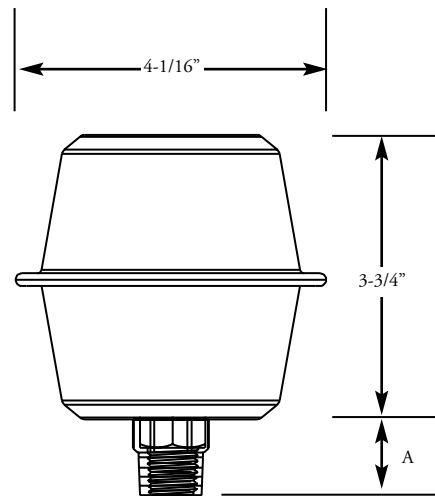

Helpful Tip:

Prevention of oil contamination and degradation is very often the most reliable means of preventing equipment failures. By minimizing the ways that contamination can enter equipment, lubricant cleanliness levels are increased. Products such as the WATCHDOG oilers, Opto-Matic closed system oilers, Equalizer expansion chambers, and WATCHDOG breathers, can help lubricants remain cleaner longer.

SELECTION CHART

Model No.	Connection (NPT)	Capacity*	Dim.(A) (in.)
31815	3/8	25 cu. in.	7/8
31816	1/2	25 cu. in.	1
31817	3/4	25 cu. in.	1-1/4

SPECIFICATIONS

Body	Stainless Steel
Diaphragm	Viton®
Maximum Operating Temperature	350°F

* For application assistance on calculating required capacities, please contact Trico or visit our web site for an online worksheet at www.tricomfg.com/size-expand-worksheet.asp

Selection of an Expansion Chamber

DETERMINE TOTAL AIR EXPANSION

To determine the correct expansion chamber size required for your application, obtain the following data and follow the steps listed below. Please visit our website for assistance on calculating required capacities at www.tricomfg.com/size-expand-worksheet.asp

1. The amount of oil, in ounces, normally in the bearing housing. _____ oz.
2. Multiply above answer by 1.804 to obtain _____ in³ (oil volume).
Place this value into the table below **STEPS A & B** in³ (oil volume).
3. The temperature range of the bearing housing. High _____ °F Low _____ °F.
Place High & Low temperature in **STEP C**. Subtract the low from the high and place in **STEP A** (high-low temp).
4. Complete **STEP A**. Multiply oil volume by temperature difference and coefficient of expansion. (NOTE: .0004 is coefficient of expansion for most turbine oils).
Place answer in **STEP D**, in³ (oil expansion).
5. The total volume of the bearing housing. Many customers may not know this.
Contact your pump manufacturer for this information. _____ oz. (total volume).
6. Multiply answer from above by 1.804 to obtain _____ in³ (sump volume).
Place this value into the table **STEP B** in³ (sump volume).
7. Complete **STEP B**, subtract in³ (oil volume) from in³ (sump volume) to get in³ (air volume) and place answer in both places in **STEP C**, in³ (air volume).
8. Follow instructions in **STEP C** to get in³ (air expansion). Place answer into **STEP D** in³ (air expansion).
9. Complete **STEP D** by adding to get in³ (total expansion), with this information you can select the correct size expansion chamber for your application.

BEFORE STARTING, OBTAIN THE FOLLOWING DATA:

1	Amount of Oil in Housing (oz.)
<input style="width: 100%; height: 100%;" type="text"/>	

2	Temp. Range of Housing (°F)
High	<input style="width: 80%; height: 20px;" type="text"/>
Low	<input style="width: 80%; height: 20px;" type="text"/>

3	Total Volume in Housing (oz.)
<input style="width: 100%; height: 100%;" type="text"/>	

STEP A	Multiply the volume of oil with the temperature span to get oil expansion. _____ in ³ (oil volume) X _____ °F (high-low temp) X .0004 = _____ in ³ (oil expansion)
STEP B	Subtract the oil volume from the sump volume to get air volume. _____ in ³ (sump volume) - _____ in ³ (oil volume) = _____ in ³ (air volume)
STEP C	Determine the absolute temperature range for air, divide high temp + 460 by low temp + 460. Multiply (air volume) with temperature factor. Then subtract the (air volume) to get the air expansion for the maximum change in temperature. $\text{_____ in}^3 \text{ (air volume)} \times \frac{(\text{_____ high temp} + 460)}{(\text{_____ low temp} + 460)} - \text{_____ in}^3 \text{ (air volume)} = \text{_____ in}^3 \text{ (air expansion)}$
STEP D	Add (oil expansion) with (air expansion) to get total expansion. _____ in ³ (oil expansion) + _____ in ³ (air expansion) = _____ in ³ (total expansion)

Introduction to Visual Inspection Units

Monitoring proper levels and the condition of operating fluids is essential in many industrial applications. Although important, these elements are often overlooked and cause detrimental affects to the life of the fluid as well as, the equipment it supplies. Fortunately, Trico offers products such as, viewports and liquid level gauges, which provide an easy and accurate method for visually inspecting many types of industrial fluids. In addition, Trico also offers sump bottles as a further means for visual inspection. These bottles function as a collection chamber for both sediments and free water that can invade oil sump applications. Using these products in conjunction or separately, can have positive influences on fluid and equipment costs. By taking a proactive approach and installing visual inspection products, the life of your industrial equipment can be significantly prolonged.

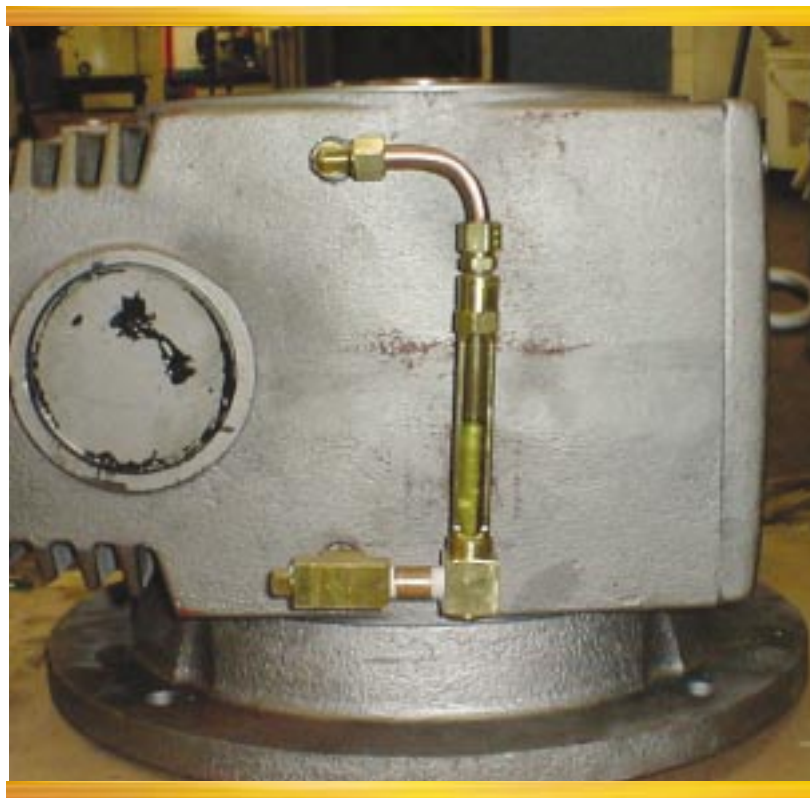

Closed system liquid level gauge with pressure balancing line connected to a gear box housing.

Sump Bottles



APPLICATIONS:

Trico sump bottles are used as collection chambers on bearing housings and other oil sump applications. They collect water and contaminants, and have a drain plug for easy inspection and removal of fluids.

FEATURES:

- Easy open/close drain valve.
- Plastic reservoirs have reinforcing ribs for long life and impact resistance.
- Copper brazing of all steel connections provides long life and leak proof design.
- Zinc plating resists corrosion.

SPECIFICATIONS

Max. Operating Temp.	165°F Continuous
Reservoir	Butyrate Plastic
Gasket	Buna-N
Materials	Steel and Brass
Finish	Bright Zinc Plated

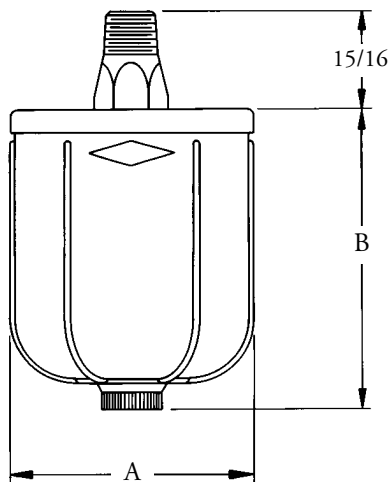

SELECTION CHART

Model No.	Capacity	Connection (NPT)	Dimensions (in.)	
			A	B
31311	1 oz.	1/8	1-5/8	1-5/8
31321	2 oz.	1/8	1-15/16	2-1/16
31341	4 oz.	1/8	2-5/16	2-7/8
31342	4 oz.	1/4	2-5/16	2-7/8
31382	8 oz.	1/4	2-5/8	4

Helpful Tip:

Oil should be clear and bright in sump bottles. If water or sediment is observed, remove immediately and investigate source. Up to 70% of equipment fails prematurely due to contamination in lubricants.

Liquid Level Gauges



APPLICATIONS:

Liquid level gauges provide easy viewing in many industrial applications. They are ideal for bearings, transformers, and many other non-pressure applications.

FEATURES:

- Guards are standard on all sights and may be rotated 360° for easy viewing.
- Glass tubes offer high temperature use to 250°F.
- Wide range of mounting styles to fit most applications.
- Optional top caps are available.

HOW TO ORDER:

1. Choose the type of gauge mounting and configuration:
 - BG - Straight Male Thread
 - BE - Short Male Elbow
 - BF - Female Elbow
 - BL - Long Male Elbow
2. Select model number using selection charts for correct size of gauge.
3. Optional top caps are available. Add the following suffixes to the part number:
 - “C” - A cap with a 1/8 NPT port is provided for use in closed system applications. This is a non-vented design.
 - “F” - A filter is installed in the vent cap to minimize contamination.
 - “S” - A snap-lid filler cap is provided in place of the standard cap for easy filling.

SPECIFICATIONS

Construction	Brass
Sight	Glass
Seals	Viton®
Max. Operating Temp.	250°F

CLOSED SYSTEM TOP CAPS

For closed system applications, all liquid level gauges can be ordered with a top cap that has a 1/8 NPT port for installing a pressure balancing line to the reservoir. Contamination from water and particulate is reduced and equipment life is prolonged.

To make this conversion, use the selection chart below to order the appropriate size cap. To order a new liquid level gauge with this cap installed, add the suffix “C” to the part number.

TOP CAP SELECTION CHART

Model No.	Description	Gauge Size	Connection Thread Size
13217R	Closed System Conversion Cap	1/2" Glass Diameter	1/8 NPT
13218R		5/8" Glass Diameter	1/8 NPT

SELECTION CHART - LONG ELBOW

Model No.	Dimensions (in.)					
	A	B	C	D	E	Square
BL-0138-2	1/4	1-3/8	2-15/16	1-3/4	1/2	11/16
BL-0138-3	3/8	1-3/8	2-15/16	1-3/4	1/2	11/16
BL-0178-2	1/4	1-7/8	3-7/16	1-3/4	1/2	11/16
BL-0178-3	3/8	1-7/8	3-7/16	1-3/4	1/2	11/16
BL-0225-2	1/4	2-1/4	3-13/16	1-3/4	1/2	11/16
BL-0225-3	3/8	2-1/4	3-13/16	1-3/4	1/2	11/16
BL-0275-2	1/4	2-3/4	4-5/16	1-3/4	1/2	11/16
BL-0275-3	3/8	2-3/4	4-5/16	1-3/4	1/2	11/16
BL-0325-2	1/4	3-1/4	4-13/16	1-3/4	1/2	11/16
BL-0325-3	3/8	3-1/4	4-13/16	1-3/4	1/2	11/16
BL-0525-2	1/4	5-1/4	6-13/16	1-3/4	1/2	11/16
BL-0525-3	3/8	5-1/4	6-13/16	1-3/4	1/2	11/16
BL-0725-2	1/4	7-1/4	8-13/16	1-3/4	1/2	11/16
BL-0725-3	3/8	7-1/4	8-13/16	1-3/4	1/2	11/16
BL-0550-3	3/8	5-1/2	7-1/4	2-1/2	5/8	7/8
BL-0750-3	3/8	7-1/2	9-1/4	2-1/2	5/8	7/8

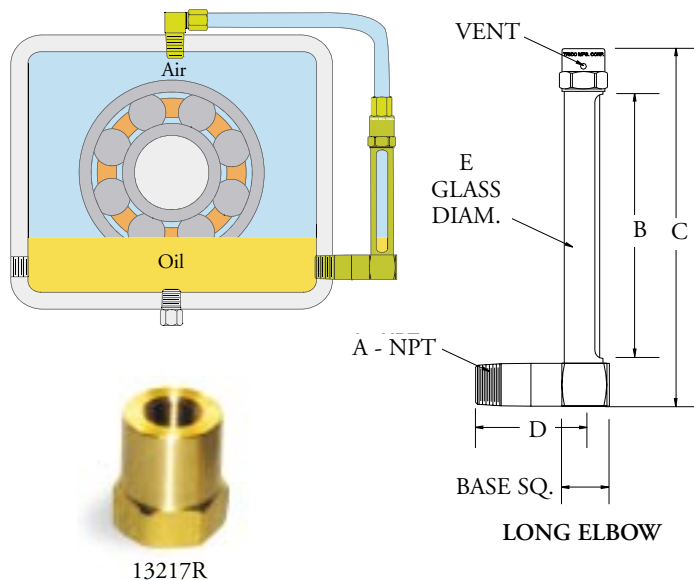

Liquid Level Gauges

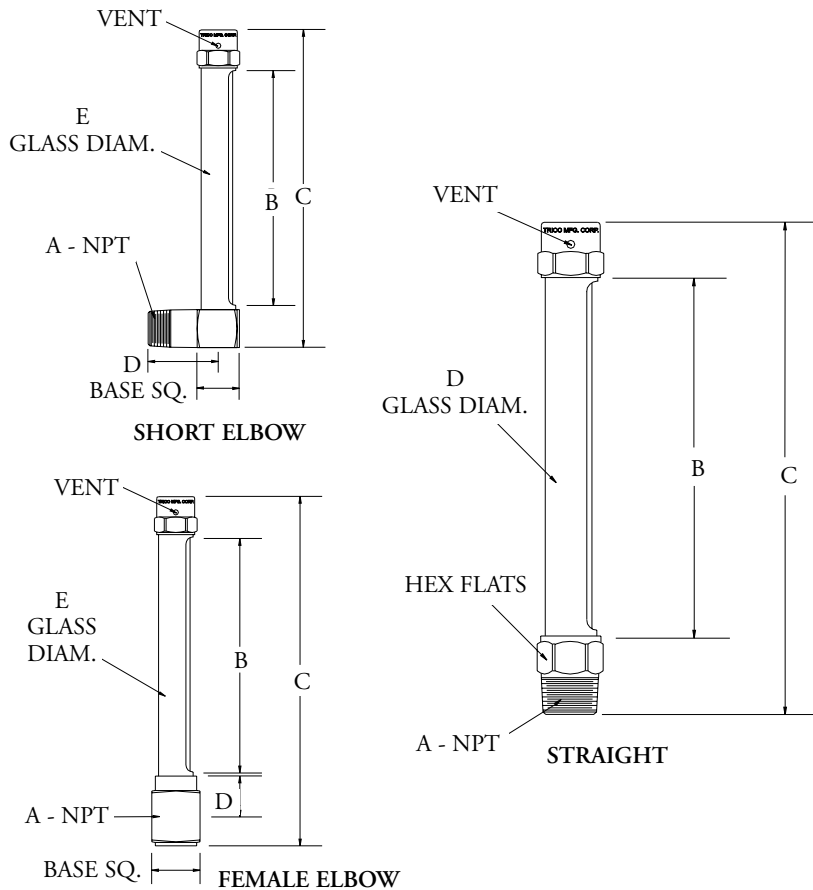

SELECTION CHART - STRAIGHT

Model No.	Dimensions (in.)				
	A	B	C	D	HEX
BG-0138-2	1/4	1-3/8	3-1/8	1/2	11/16
BG-0138-3	3/8	1-3/8	3-1/8	1/2	11/16
BG-0178-2	1/4	1-7/8	3-5/8	1/2	11/16
BG-0178-3	3/8	1-7/8	3-5/8	1/2	11/16
BG-0225-2	1/4	2-1/4	4	1/2	11/16
BG-0225-3	3/8	2-1/4	4	1/2	11/16
BG-0275-2	1/4	2-3/4	4-1/2	1/2	11/16
BG-0275-3	3/8	2-3/4	4-1/2	1/2	11/16
BG-0325-2	1/4	3-1/4	5	1/2	11/16
BG-0325-3	3/8	3-1/4	5	1/2	11/16
BG-0425-2	1/4	4-1/4	6	1/2	11/16
BG-0425-3	3/8	4-1/4	6	1/2	11/16
BG-0525-2	1/4	5-1/4	7	1/2	11/16
BG-0525-3	3/8	5-1/4	7	1/2	11/16
BG-0725-2	1/4	7-1/4	9	1/2	11/16
BG-0725-3	3/8	7-1/4	9	1/2	11/16
BG-0550-2	1/4	5-1/2	7-1/4	5/8	13/16
BG-0550-3	3/8	5-1/2	7-1/4	5/8	13/16
BG-0550-4	1/2	5-1/2	7-3/8	5/8	7/8
BG-0750-2	1/4	7-1/2	9-1/4	5/8	13/16
BG-0750-3	3/8	7-1/2	9-1/4	5/8	13/16

SELECTION CHART - SHORT ELBOW

Model No.	Dimensions (in.)					
	A	B	C	D	E	Square
BE-0138-2	1/4	1-3/8	2-15/16	1-1/4	1/2	11/16
BE-0138-3	3/8	1-3/8	2-15/16	1-1/4	1/2	11/16
BE-0178-2	1/4	1-7/8	3-7/16	1-1/4	1/2	11/16
BE-0178-3	3/8	1-7/8	3-7/16	1-1/4	1/2	11/16
BE-0225-2	1/4	2-1/4	3-13/16	1-1/4	1/2	11/16
BE-0225-3	3/8	2-1/4	3-13/16	1-1/4	1/2	11/16
BE-0275-2	1/4	2-3/4	4-5/16	1-1/4	1/2	11/16
BE-0275-3	3/8	2-3/4	4-5/16	1-1/4	1/2	11/16
BE-0325-2	1/4	3-1/4	4-13/16	1-1/4	1/2	11/16
BE-0325-3	3/8	3-1/4	4-13/16	1-1/4	1/2	11/16
BE-0425-2	1/4	4-1/4	5-13/16	1-1/4	1/2	11/16
BE-0425-3	3/8	4-1/4	5-13/16	1-1/4	1/2	11/16
BE-0525-2	1/4	5-1/4	6-13/16	1-1/4	1/2	11/16
BE-0525-3	3/8	5-1/4	6-13/16	1-1/4	1/2	11/16
BE-0725-2	1/4	7-1/4	8-13/16	1-1/4	1/2	11/16
BE-0725-3	3/8	7-1/4	8-13/16	1-1/4	1/2	11/16
BE-0550-2	1/4	5-1/2	7-1/4	1-3/4	5/8	7/8
BE-0550-3	3/8	5-1/2	7-1/4	1-3/4	5/8	7/8
BE-0750-2	1/4	7-1/2	9-1/4	1-3/4	5/8	7/8
BE-0750-3	3/8	7-1/2	9-1/4	1-3/4	5/8	7/8

SELECTION CHART - FEMALE ELBOW

Model No.	Dimensions (in.)					
	A	B	C	D	E	Square
BF-0138-2	1/4	1-3/8	3-1/2	1/2	1/2	7/8
BF-0138-3	3/8	1-3/8	3-1/2	1/2	1/2	7/8
BF-0178-2	1/4	1-7/8	4	1/2	1/2	7/8
BF-0178-3	3/8	1-7/8	4	1/2	1/2	7/8
BF-0225-2	1/4	2-1/4	4-3/8	1/2	1/2	7/8
BF-0225-3	3/8	2-1/4	4-3/8	1/2	1/2	7/8
BF-0275-2	1/4	2-3/4	4-7/8	1/2	1/2	7/8
BF-0275-3	3/8	2-3/4	4-7/8	1/2	1/2	7/8
BF-0325-2	1/4	3-1/4	5-3/8	1/2	1/2	7/8
BF-0325-3	3/8	3-1/4	5-3/8	1/2	1/2	7/8
BF-0425-2	1/4	4-1/4	6-3/8	1/2	1/2	7/8
BF-0425-3	3/8	4-1/4	6-3/8	1/2	1/2	7/8
BF-0525-2	1/4	5-1/4	7-3/8	1/2	1/2	7/8
BF-0525-3	3/8	5-1/4	7-3/8	1/2	1/2	7/8
BF-0725-3	3/8	7-1/4	9-3/8	1/2	1/2	7/8
BF-0550-3	3/8	5-1/2	7-3/4	9/16	5/8	1
BF-0750-3	3/8	7-1/2	9-3/4	9/16	5/8	1

Introduction to Oil Sampling/Analysis

OIL SAMPLING

Contamination of machinery lubricants is a major problem for many manufacturers. In fact, it has been stated that six to seven percent of the gross national product (\$240 Billion) is required just to repair the damage caused by mechanical wear, which is caused by contamination. However, when contamination is controlled, the life span of a machine's vital components can be extended by as much as 50 times. It's for these reasons and many more that routine sampling is done.



The process of sampling is not only a vital and necessary function in identifying contaminants and contamination levels, but also in understanding the current and future requirements of the equipment and the quality of the lubricant in general. Regularly scheduled oil sampling and analysis programs have become an increasingly important tool for uncovering information necessary to extend the life of your equipment and oil change intervals and minimize maintenance costs associated with oil change outs, labor, repairs and downtime.

Oil sampling technology today is making the process of collecting and analyzing samples much more effective and accurate. Trico offers the latest sampling supplies and accessories, including sample ports and collection devices, which are designed to extract system and component specific samples that are both representative and repeatable from the best diagnostic locations in the most effective ways possible.

OIL ANALYSIS

Understanding the concept of oil sampling and the benefits involved is an important part of total lubrication management, however, reaping the benefits may require much more. Often, it requires an intimate knowledge of the equipment, its internal design, the system design, the present operating and environmental conditions, the ability to regularly test samples in a safe and contaminant-free environment and recommend and implement corrective actions as needed.

With these challenges in mind, Trico now offers services to inspect, analyze, and report on the operating conditions of entire manufacturing facilities' machinery. Trico offers technical assistance to improve, repair and/or modify equipment and lubrication procedures to meet performance goals and offers on-site or in-house training on best-in-practice ways of implementing lubricant screening regimens, equipment and plant assessments and lubrication management programs.

These services include:

- Auditing - The service includes mapping out lubrication requirements from incoming materials, to handling, to equipment, and then disposal.
- Consulting - Working with plant maintenance personnel to increase equipment reliability, improve lubrication practices, identify sample point locations and hardware requirements for effective diagnostic capabilities, assist, implement or evaluate equipment condition monitoring programs.
- Training - On-site or off-site training sessions targeting effective lubrication management principles, practices, and effective implement of preventative maintenance, predictive maintenance, and proactive maintenance programs.
- Monitoring - Oil samples are taken and analyzed as a preventative maintenance tool and/or diagnostic means to determine cause of equipment failure. Oil is tested for a variety of critical factors including water, particulate, wear material, etc.



Oil Sampling Ports

Where and how oil samples are collected are two of the most important functions of the oil sampling process. Without a representative sample, further oil analysis efforts will be ineffective. That's why Trico sample ports are designed to draw samples from the most representative areas from industrial equipment. Trico sample ports are also designed to collect samples under the equipment's typical operating condition - another important factor.

The collection process is a simple, fast and accurate way of sampling hydraulic, lubricating, and circulating systems. Access to systems is done through the use of a mating sample port adapter. The sample port adapter screws onto the sample port. Oil samples can then be drawn from the system and placed into a clean sampling bottle for analysis.

To guard against contaminating the sample and for superior leak protection, Trico sampling ports all feature a check valve and a viton o-ring seal cap.

Trico sample ports are available in several types and sizes to match the varying requirements of manufacturers. Please see below for a complete listing and specifications. To complement the sample ports, there are a number of sample port adapters available, as well.

SPECIFICATIONS

Maximum Working Pressure	9000 PSI (630 bar)
Connect Under Pressure	5800 PSI (400 bar)
Check Valve Ball	Stainless Steel
O-Ring	Viton®
Maximum Operating Temperature	-4°F to 392°F

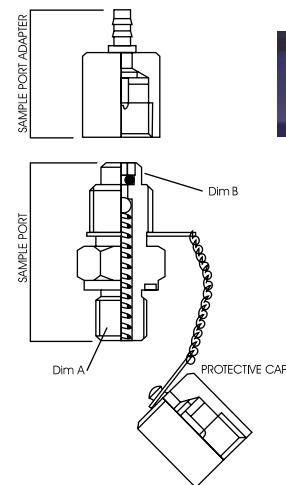

Helpful Tip:
A sample port adapter must be used to draw a sample from Trico's sample ports and pitot tubes.



SAMPLE PORTS

Carbon Steel P/N	Stainless Steel P/N	Port Connection (Dim A)	Dim B
36100	36102	1/8" NPT	M16x2
36101	36103	1/4" NPT	M16x2

Note: BSPT, BSPP, and O-ring boss threads are available upon request, please contact Trico's Customer Service.

FEATURES:

- Protective cap seals against dirt and moisture.
- Cap connected to sample port with a heavy brass chain to prevent loss.
- Sample directly from lubricating oil while equipment is running.
- Minimizes introduction of contamination into system.
- Used in conjunction with proper accessories sample ports are adaptable to pressure, static, and vacuum locations.



36133



36109

Sample port adapter is used with any pitot tube, liquid level gauge, or sample ports that have a black cap.



36104, 36105, 36106

Gauge adapter can be used to attach pressure gauges for troubleshooting purposes when barb fitting is removed.

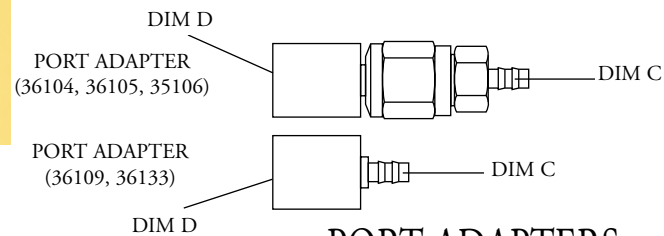

PORT ADAPTERS

Part Number	Port Connection (Dim C)	Dim D	Material
36104	Barb for 1/4" OD Tube	M16x2	Carbon Steel
36105	Barb for 5/16" OD Tube	M16x2	Carbon Steel
36106	Barb for 1/2" OD Tube	M16x2	Carbon Steel
36109*	Barb for 1/4" OD Tube	M16x2	Plated Steel
36133*	Barb for 1/4" OD Tube	M16x2	Plated Steel

*Does not include gauge adapter, which can be used to attach pressure gauges for troubleshooting purposes when barb fitting is removed.

Oil Sampling Ports

The micro-bore test hose is used for remote or difficult to reach oil sampling locations, as well as locations that are too close to moving parts, making the task too dangerous. The micro-bore test hose is designed to make oil sampling safe and convenient. The hose assembly is available in various lengths for ease of installation. A bulkhead sample port is available for installations that require panel mounting.

SPECIFICATIONS

Maximum Working Pressure	9000PSI (630bar)
Internal Dia	.08" (2mm)
Minimum Bending Radius	.75"
Thread connection	M16x2

MICRO-BORE TEST HOSE

Part Number	Length
36119	12"
36120	24"
36121	36"
36122	48"
36123	60"
36124	72"
36125	96"
36126	120"
36127	240"

Used for remote or difficult to reach sampling locations.



BULKHEAD SAMPLE PORT

(for use with Micro-Bore Test Hose)

Part Number	Port Connection	Material
36128	M16 x 2 Male	Carbon Steel

GAUGE ADAPTERS

Part Number	Port Connection (Dim A)	Dim B	Material
36107	1/4" NPT Female	M16x2	Carbon Steel
36108	1/2" NPT Female	M16x2	Carbon Steel

Gauge adapter can be used with sample ports to attach pressure gauges for troubleshooting purposes.

GAUGE ADAPTER
(36107, 36108)

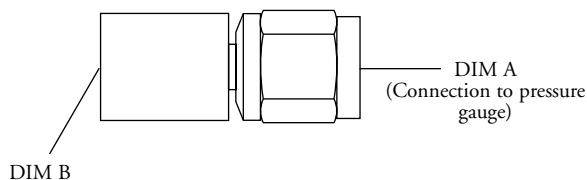

Helpful Tip:

Always flush out the "dead zone" of the micro-bore test hose using a waste bottle before taking an oil sample.



Pitot Tube Sampling Ports

Trico's Pitot Tube sampling ports are designed to provide a safe, simple and effective method of sampling fluids from sumps and non-flooded horizontal drain lines. They ensure oil samples are drawn from the most appropriate location of the sump reservoir, and that the sample is taken from the exact location inside the system each time, which is important for maintaining consistency in routine sampling. The thick wall tubing can be bent and directed to the ideal sampling location with the use of a swivel adapter.

FEATURES:

- Pitot Tubes are equipped with sample ports.
- Available in 12", 18", 24" and 72" lengths.
- Installs easily into drain, fill or sampling pipe ports.
- Swivel options available for bent tubes in confined locations.

SPECIFICATIONS

Maximum Pressure	500 PSI (34.5 bar)
Material	Carbon Steel or Stainless Steel
Check Valve Ball	Stainless Steel
Seal	Viton
Maximum Operating Temperature	-4°F to 392°F

CARBON STEEL SAMPLE PORT AND TUBE

Fixed Adapter	Swivel Adapter	Tube Length	Fitting
36200	36213	12"	1/4" NPT Male
36201	36214	18"	1/4" NPT Male
36202	36215	24"	1/4" NPT Male
36203	36216	72"	1/4" NPT Male

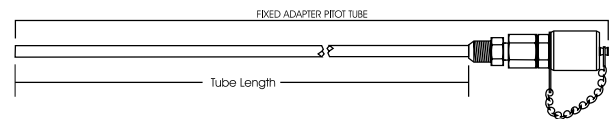
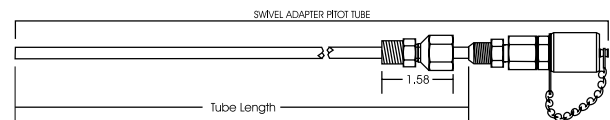

CARBON STEEL SAMPLE PORT AND STAINLESS STEEL TUBE

Fixed Adapter	Swivel Adapter	Tube Length	Fitting
36204	36217	12"	1/4" NPT Male
36207	36220	18"	1/4" NPT Male
36210	36223	24"	1/4" NPT Male



STAINLESS STEEL SAMPLE PORT AND CARBON STEEL TUBE

Fixed Adapter	Swivel Adapter	Tube Length	Fitting
36205	36218	12"	1/4" NPT Male
36208	36221	18"	1/4" NPT Male
36211	36224	24"	1/4" NPT Male

STAINLESS STEEL SAMPLE PORT AND TUBE

Fixed Adapter	Swivel Adapter	Tube Length	Fitting
36206	36219	12"	1/4" NPT Male
36209	36222	18"	1/4" NPT Male
36212	36225	24"	1/4" NPT Male

Helpful Tip:

A sample port adapter must be used to draw a sample from Trico's Pitot Tubes. Pitot tubes purchased after February, 2005 please use sample port adapter 36133. To upgrade pitot tubes purchased prior to February 2005 to high viscosity sampling, please replace valve assembly with 23001R.

Liquid Level Gauge Sample Ports

Liquid Level Gauge Sample Ports provide easy viewing of fluid levels and oil condition in many industrial applications. They are ideal for bearing housings and other non-pressurized applications. Liquid Level Gauge Sample Ports include a Pitot Tube for static sampling, which provides repetitive, representative oil sampling.

FEATURES:

- Guards are standard on all sights and may be rotated 360° for easy viewing of fluid level and condition.
- Liquid Level Gauge Sample Ports are equipped with Pitot Tubes in lengths of 12", 18", and 24".
- Level gauge sights are available in sizes from 1-3/8" to 7-1/2" in length.
- For use with non-pressurized systems.

SPECIFICATIONS

Material (Level Gauge)	Brass
Material (Pitot Tube)	Carbon Steel
Sight	Glass
Seals	Viton
Maximum Operating Temperature	250°F

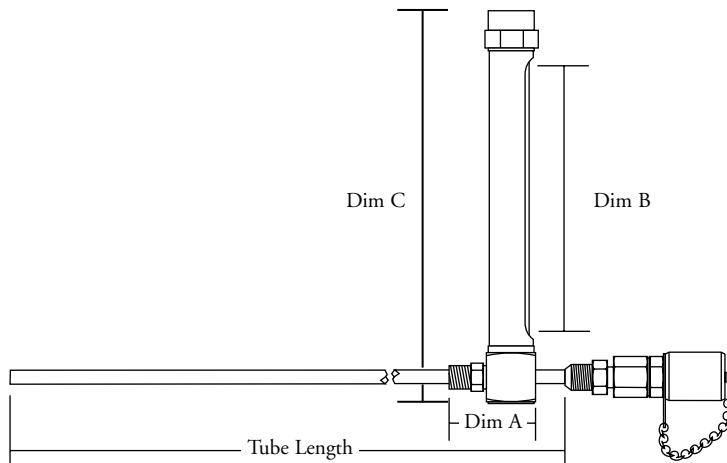

SELECTION CHART

Pitot Tube Length			Dim A	Sight Length Dim B	Dim C	NPT Male Fitting
12"	18"	24"				
36300	36322	36344	2.18"	1-3/8"	2-5/16"	1/4"
36301	36323	36345	2.18"	1-7/8"	3-7/16"	1/4"
36302	36324	36346	2.18"	2-1/4"	3-13/16"	1/4"
36303	36325	36347	2.18"	2-3/4"	4-5/16"	1/4"
36304	36326	36348	2.18"	3-1/4"	4-13/16"	1/4"
36305	36327	36349	2.18"	4-1/4"	5-13/16"	1/4"
36306	36328	36350	2.18"	5-1/4"	6-13/16"	1/4"
36307	36329	36351	2.18"	5-1/2"	7-1/4"	1/4"
36308	36330	36352	2.18"	7-1/2"	9-1/4"	1/4"
36366	36388	36410	2.00"	1-3/8"	2-5/16"	3/8"
36367	36389	36411	2.00"	1-7/8"	3-7/16"	3/8"
36368	36390	36412	2.00"	2-1/4"	3-13/16"	3/8"
36369	36391	36413	2.00"	2-3/4"	4-5/16"	3/8"
36370	36392	36414	2.00"	3-1/4"	4-13/16"	3/8"
36371	36393	36415	2.00"	4-1/4"	5-13/16"	3/8"
36372	36394	36416	2.00"	5-1/4"	6-13/16"	3/8"
36373	36395	36417	2.00"	5-1/2"	7-1/4"	3/8"
36374	36396	36418	2.00"	7-1/2"	9-1/4"	3/8"



Helpful Tip:

Liquid Level Gauge Sample Ports purchased after February 2005, please use sample adapter 36133 to draw oil sample from system. To upgrade liquid level gauge sample ports purchased prior to February 2005 to high viscosity sampling, please replace valve assembly with 23001R.

*Stainless steel units are available upon request, please contact Trico's Customer Service.

Spacer Flange Sampling Ports

In situations where flanged fittings provide the optimum and representative place for sampling, Trico's Spacer Flange Sampling Ports make it easy. The Code 61 o-ring flange, fitted with Trico's sample port, allows you to pull your sample between any two standard flanges. Code 62 and stainless steel o-ring flanges are also available.

FEATURES:

- For use with high-pressure hydraulic applications.
- Meets Code 61 and Code 62 pressure ratings for four-bolt flanges.



SPECIFICATIONS

Max Pressure	3000 PSI (274 bar) – Code 61 6000 PSI (548 bar) – Code 62
Connect Under Pressure	5800 PSI (400 bar) – Code 62
Material	Carbon Steel or Stainless Steel
Check Valve Ball	Stainless Steel
Seals	Viton
Maximum Operating Temperature	-4°F to 392°F

SELECTION CHART

Code 61	Code 62	Pipe Diameter	Material
36700	36718	1/2"	Carbon Steel
36701	36719	3/4"	Carbon Steel
36702	36720	1"	Carbon Steel
36703	36721	1-1/4"	Carbon Steel
36704	36722	1-1/2"	Carbon Steel
36705	36723	2"	Carbon Steel
36706	36724	2-1/2"	Carbon Steel
36707	36725	3"	Carbon Steel
36709	36727	1/2"	Stainless Steel
36710	36728	3/4"	Stainless Steel
36711	36729	1"	Stainless Steel
36712	36730	1-1/4"	Stainless Steel
36713	36731	1-1/2"	Stainless Steel
36714	36732	2"	Stainless Steel
36715	36733	2-1/2"	Stainless Steel
36716	36734	3"	Stainless Steel

Helpful Tip:

A sample port adapter must be used to draw a sample from Trico's spacer flange sampling ports.

Filter carts are available as an effective method to transfer new or used hydraulic or gear oils from drums and reservoirs, please see Filtration System document for additional information.

Catch Pipe Sampling Ports

Catch Pipe Sample Ports are designed to provide a simple and effective method of sampling fluids from a non-flooded line. The internal trap has a drain hole for continuous trap flushing, providing a truly representative oil sample. The internal trap design is packaged in an extended piping nipple with NPT or weld-end for simple installation. Equipped with a standard Trico Sample Port, the sampling method is further simplified for reduced chances of contamination.

FEATURES:

- Internal trap has drain to avoid contamination build-up.
- For use in non-pressurized, non-flooded vertical lines.

SPECIFICATIONS

Material (pipe)	Stainless Steel
Material (sampling port)	Carbon Steel or Stainless Steel
Check Valve Ball	Stainless Steel
Seals	Viton
Maximum Operating Temperature	-4°F to 392°F

CATCH PIPE WITH CARBON STEEL SAMPLE PORT

Pipe Thread	Weldable Ends	Thread Size	Dim A	Dim B
36750	36758	1-1/4"	6"	3.5"
36751	36759	1-1/2"	6"	3.5"
36752	36760	2"	8"	4.5"
36753	36761	2-1/2"	8"	4.5"
36754	36762	3"	10"	5.5"
36755	36763	4"	10"	5.5"
36756	36764	6"	12"	6.5"

CATCH PIPE WITH STAINLESS STEEL SAMPLE PORT

Pipe Thread	Weldable Ends	Thread Size	Dim A	Dim B
36766	36774	1-1/4"	6"	3.5"
36767	36775	1-1/2"	6"	3.5"
36768	36776	2"	8"	4.5"
36769	36777	2-1/2"	8"	4.5"
36770	36778	3"	10"	5.5"
36771	36779	4"	10"	5.5"
36772	36780	6"	12"	6.5"

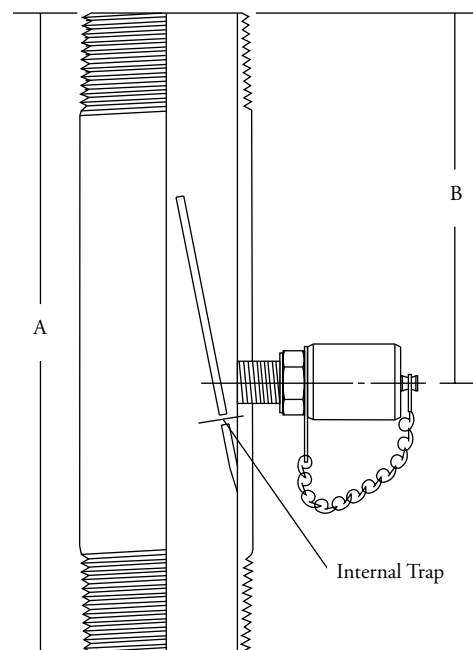

Helpful Tip:

A sample port adapter must be used to draw a sample from Trico's catch pipe sampling ports.

Vacuum Pump and Sampling Accessories

A necessary tool for extracting an oil sample from the sample port, Trico's Vacuum Pump is compact for ease of transport. When used in combination with a sample port adapter, flexible tubing, and a 4-ounce sterilized sample bottle the user is able to connect to any sample port for contamination free oil sampling in the most representative locations.

Trico also offers a heavy-duty Vacuum Pump model that includes a release valve.

FEATURES:

- Draws a vacuum of 27 inches of Hg (Mercury)
- Uses 3/16" to 5/16" tubing

VACUUM PUMPS

Part Number	Description
36800	Vacuum Pump, Standard
36801	Vacuum Pump, Heavy-Duty with Release Valve

Note: Bottles sold separately



OIL SAMPLING BOTTLES

Part Number	Description
36813	Clean, 4 oz Sample Bottle, Single
36814	Clean, 4 oz Sample Bottle, Case of 576
36816	Clean, 8 oz Sample Bottle, Regular Wall, Single
36817	Clean, 8 oz Sample Bottle, Regular Wall, Case of 270
36819	16 oz Oil Sample Purge Bottle
36821	Black Plastic Mailer for 4 oz Bottles



TUBING

Part Number	Description
36806	1/4" OD Poly Tubing, 100 ft Roll
36807	5/16" OD Poly Tubing, 100 ft Roll
36808	1/2" OD Poly Tubing, 100 ft Roll
36809	1/4" OD Poly Tubing, 500 ft Roll
36810	5/16" OD Poly Tubing, 500 ft Roll
36811	1/2" OD Poly Tubing, 500 ft Roll

Helpful Tip:

Prior to sending oil sample to lab, mark clearly on bottle make and model of equipment, brand, type, and weight of oil and any other necessary details to ensure correct analysis when results are returned from the lab.

Reservoir Breather Kits

Because airborne contaminants can quickly disrupt and negate your sample, Trico offers specially designed Breather Kits. These kits feature a two-stage breather system that utilizes a filter to block airborne particles and desiccant to remove harmful, unwanted moisture. The system ensures a permanent closure on all hydraulic reservoirs and makes sure the lubricating fluid remains closed off from airborne contamination throughout the sampling process.

An optional filter reminder vacuum gauge can be used to indicate when the filter element on the breather has become clogged.

A male quick connect can be plumbed to the 6-bolt adapter plate (this plate replaces the standard filler/breather cap) to fit a down pipe for filling reservoirs with new oil through a filter cart without opening the system to the environment.

For static sampling of oil from the system reservoir, the 6-bolt adapter plate can incorporate a sample port connected to a sample tube. The tube conveniently extends to the middle of the fluid level in the system reservoir to allow samples to be taken from the exact location inside the system every time.

FEATURES:

- Optional filter reminder indicates remaining life of filter element.
- Color coded desiccant changes colors indicating replacement is needed, when maximum adsorption is reached.
- Optional sample port is available with sampling drop tubes of 12", 18", and 24" in length.



SPECIFICATIONS DESICCANT BREATHERS

Breather Size	Filter	Desiccant	Silica Gel Volume	Water Capacity (lbs)	Air Flow	Desiccant Replaceable
39102	2 microns	Gold to dark green	2.31 lb	0.9	35 CFM (260 gpm of fluid volume exchange)	No

Note: Trico Watchdog and Watchdog EX Series Breathers can be readily used with the Reservoir Breather Kits, please contact Trico for additional information.

Reservoir Breather Kits

6 BOLT ADAPTER PLATE WITHOUT SAMPLE PORT

Part Number	Breather Size	Filter Reminder	Quick Connect
36902	39102	No	N/A
36903	39102	No	1/2" Male
36904	39102	No	1/2" Female
36914	39102	Yes	N/A
36915	39102	Yes	1/2" Male
36916	39102	Yes	1/2" Female

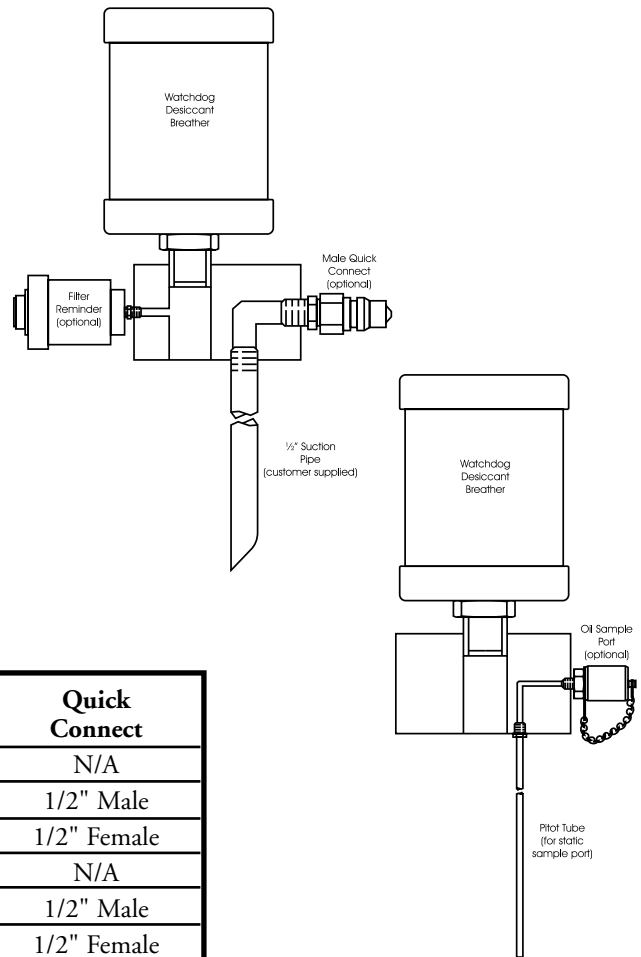

6 BOLT ADAPTER PLATE WITH SAMPLE PORT

Tube Length			Breather Size	Filter Reminder	Quick Connect
12"	18"	24"			
36905	36908	36911	39102	No	N/A
36906	36909	36912	39102	No	1/2" Male
36907	36910	36913	39102	No	1/2" Female
36917	36920	36923	39102	Yes	N/A
36918	36921	36924	39102	Yes	1/2" Male
36919	36922	36925	39102	Yes	1/2" Female

FILTER REMINDER

Normal, clean filter



Indicator shows filter is clogged and needs replacing.



The filter reminder indicates the service life of the filter element. The indicator allows the filter to be changed when needed, thus avoiding unnecessary labor and premature servicing. When filter reminder indicates the need for the filter element to be replaced, just push in the manual reset button when a new filter element is installed.

Helpful Tip:

Trico Watchdog and Watchdog EX Breathers can be readily used with the Reservoir Breather Kits. Please call Trico for additional information.

Introduction to Moisture Detection & Removal Systems

Moisture in lubricating oils is the root cause of prematurely damaging oil and accelerating wear of machine components. As water invades your fluids it will not only attack the additives in the oils, destroying their beneficial properties; but it will also cause damage to the machine surfaces through corrosion, and rapidly degrade the oil through increased oxidation. By understanding the effects of water contamination, it is easy to see the importance of moisture detection and removal.

Once water has entered the lubricant, it can exist in one or more of the following forms; dissolved, emulsified, or free water.

- **Dissolved water** contains water molecules that are dispersed one-by-one through the air in contact with, or within the lubricant. This form of water is invisible to the naked eye.
- **Emulsified water** contains microscopic pockets of water that are dispersed in stable suspension in the oil. As the oil ages this area of water will expand, causing the lubricant to look cloudy.
- **Free water** is the phase separation of emulsified water. Free water when mixed with the lubricant readily settles to the bottom of the equipment.

The most damaging forms of water contamination, to both the lubricant and equipment, are emulsified and free water. Therefore, it is important to measure, and or remove water contamination prior to the formation of emulsified and free water.

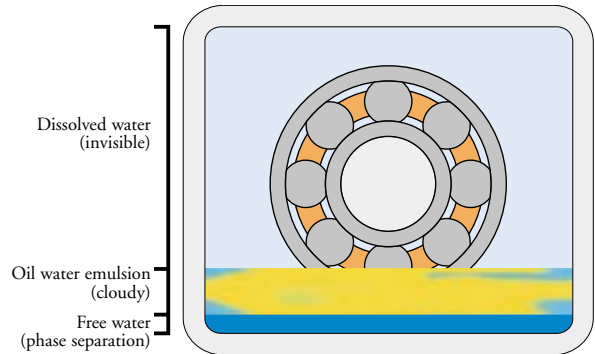

Three stages of water within a lubricating oil.

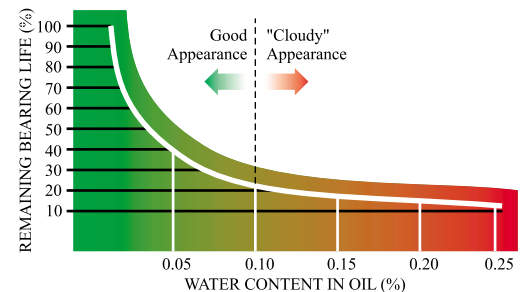

By the time free water becomes visible, damage is already occurring to the oil and equipment.

DETECTING WATER CONTAMINATION

Trico has developed on-line monitoring devices that measure moisture content as a percentage of saturated relative humidity. This measurement is taken below the saturation point of the oil, before phase separation will occur. Measuring saturated relative humidity indicates directly whether there is a risk of free water forming. The measurement is independent of the type, age, or temperature of the oil.

REMOVING WATER CONTAMINATION:

A proven method of removing water contamination from lubricating fluids is using silica gel technology. Silica gel extracts water vapor from the air as it is drawn through a silica gel bed, as well as covering a wide range of temperatures. Most units using silica gel technology to remove moisture provide a fail-proof method of determining when replacement is necessary. Trico incorporates a visual indicator to accomplish this. The silica gel used changes from gold to dark green when maximum adsorption has been reached.

Trico provides products that will detect and remove moisture from lubricating oils; however the root cause of moisture contamination should be identified and corrected to maximize the life of the lubricant and equipment.



Hydrolert Transducer installed on a bank of rollers at a steel mill facility.



Watchdog Breather installed on a hydraulic reservoir.

Hydrolert® Products

The Hydrolert products are designed to monitor levels of moisture in lubricating oils. Although there are many ways of detecting moisture in oil, most of these require that a sample be taken from the piece of equipment. Research has shown that over 85% of all oil sampling or oil changes were done either unnecessarily or after damage has already occurred.

The Hydrolert products warn of increasing moisture contamination prior to 100% Saturated Relative Humidity (SRH), allowing adequate time for corrective action to be taken before free water occurs. In addition, knowing the oil needs to be changed before it begins losing protective properties prolongs equipment life and not having to change the lubricant until saturation is imminent helps reduce maintenance, material, and labor costs.



DHS-1050



DHM-1050



The Hydrolert Transducer is a real time automatic moisture sensor for lubricants. It is designed for use with all types of rotating equipment that use oil to lubricate. When used with the Hydrolert DHS and DHM it will provide an actual Saturated Relative Humidity reading. The transducer is also capable of being incorporated into any type of system capable of reading a 4-20 ma signal. This allows the user to set alarm levels and store and interpret readings for trending purposes.

DHS-1050 & DHM-1050

- Real-time remote moisture level sensing
- Digital display for easy indication of moisture level
- Corrosion resistant construction
- Mount up to 500 feet away from transducer

- Convenient wall or panel mounting
- Continuous monitoring of moisture level

DHM-1050 (only)

- Monitors up to five locations
- Erasable sensor location decal

- Real-time moisture level sensing for lubricating oils
- Corrosive resistant construction
- Convenient 1/2" NPT mounting thread

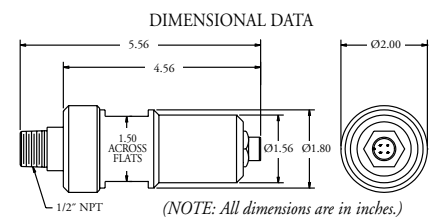

SELECTION CHART

Part Number	Description
31940	DHS-1050 (transducer included)
31941	DHM-1050 -1 transducer
31942	DHM-1050 -2 transducers
31943	DHM-1050 -3 transducers
31944	DHM-1050 -4 transducers
31945	DHM-1050 -5 transducers
31963	Hydrolert Transducer (with cord)

SPECIFICATIONS

	DHS-1050 & DHM-1050
Power Required	120 VAC
Base	Polycarbonate
Cover	Polycarbonate
Peak Accuracy	32°F to 185°F
Operating Range	-10°F to 210°F
Battery Life	N/A
Wire Connection	Quick Disconnect
Signal Output	Digital display 0-100% SRH
Connection	N/A
% RH Indication	0-100% SRH
For Use With	Hydrolert® Transducer

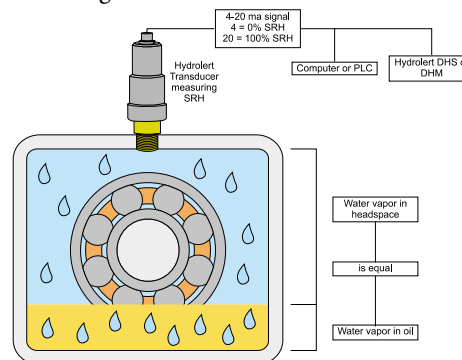

Saturated Relative Humidity (SRH) is an indicator of water concentration in a solution compared to the maximum the medium can tolerate before a phase change (free water).

SPECIFICATIONS

Power Required	14-28 VDC
Material	Anodized Aluminum
Peak Accuracy	32°F to 185°F
Operating Range	-10°F to 210°F
Wire Connection	4 Pin Quick Disconnect
NPT Connection	1/2" NPT
Output	4-20 ma
Accuracy	+/- 5 %
For Use With	DHS-1050, DHM-1050, or incorporated into a system capable of reading 4-20ma

Watchdog[®] Desiccant Breathers



APPLICATIONS:

The Watchdog[®] desiccant breathers ensure optimum protection of industrial equipment by prohibiting the entry of moisture and particulate contamination. Contaminants enter industrial equipment as pressure differentials or fluid level changes occur. The Watchdog breathers are ideal for circulating oil systems, oil sumps, process tanks, storage tanks, vacuum systems, hydraulic systems, transformer cases, or anywhere that equipment needs to be dry and clean.

Watchdog desiccant breathers perform two very important functions.

1. They adsorb unwanted moisture inside industrial equipment using silica gel technology. Unwanted moisture can lead to corrosion, shortened fluid life, and additive depletion.
2. They collect airborne solid particles by means of a dual, anti-static filter system. This reduces the amount of abrasive and damaging contaminants that create sludge build-up inside the fluid reservoir.

FEATURES:

- **Bi-directional air flow** - A 360° air flow allows air to be breathed in and out as fluid level changes or differential pressures occur.
- **Dual filtration system** - A two micron filter is located at the top and bottom of the silica gel bed. The top filter removes particle contamination from atmospheric air and the bottom helps with dust created by the silica gel beads contacting each other.
- **Water vapor adsorbent** - The silica gel used in the Watchdog desiccant breathers adsorb up to 40% of its own weight.
- **Durable construction** - Watchdog desiccant breathers are manufactured from rugged ABS plastic and impact modified acrylic.
- **Color indicator** - When maximum adsorption is reached the silica gel turns from gold to dark green, indicating replacement is needed.
- **Activated carbon** - As air is expelled, it passes through activated carbon which removes oil vapors, fumes, and odors (except for 39131, 39132, 39133, and 39134).

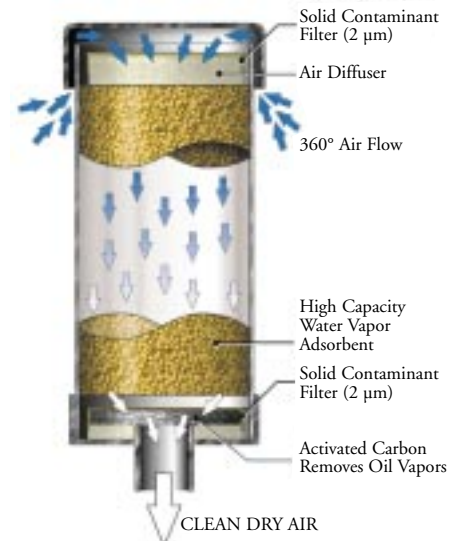

Watchdog[®] Desiccant Breathers

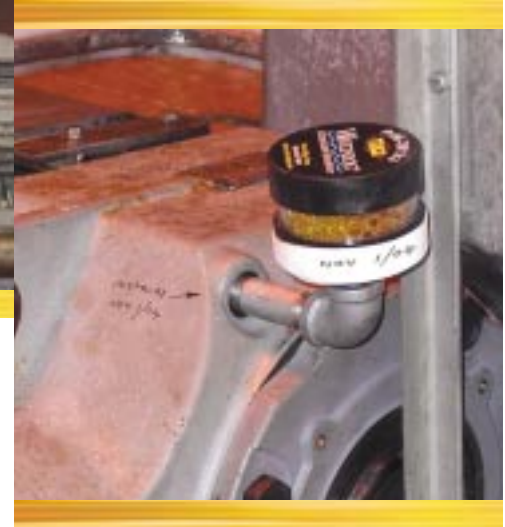

SPECIFICATIONS:

Material	ABS plastic and impact modified acrylic
Maximum Operating Temperature	(-20°F to 200°F)

SELECTION CHART

(Desiccant Breathers)

Part Number	Height (inches)	Diameter (inches)	Connection Size	Silica Gel Volume	Water Capacity lbs / ltr	Air Flow
39100	4.75	5	1" Male Friction Fit	.59 lb.	0.2 / 0.1	35 CFM (260 gpm of fluid volume exchange)
39101	6.25	5	1" Male Friction Fit	1.20 lb.	0.4 / 0.2	
39102	9.25	5	1" Male Friction Fit	2.31 lb.	0.9 / 0.5	
39108	11.25	5	2" Male NPT	3.1 lb.	1.3 / 0.6	100 CFM (750 gpm of fluid volume exchange)
39131	2	2	1/2" Female NPT	.08 lb.	.032 / .014	10 CFM (75 gpm of fluid volume exchange)
39132	3.25	2	1/2" Female NPT	.15 lb.	.056 / .027	
39133	2	3.25	1/2" Female NPT	.27 lb.	.104 / .049	
39134	3.25	3.25	1/2" Female NPT	.48 lb.	.18 / .087	

**The size of the reservoir does not determine the type of breather to use. The airflow both in and out of the reservoir determines the type to choose. Two factors create airflow, they are temperature variations (which cause very low airflow rates) and fluid volume changes.*

ACCESSORIES:

Adapters are ordered separately, please see Watchdog Breather Adapters document.

Watchdog[®] EX Series Breathers

In certain extreme operating environments such as a paper mill or in food processing where regular steam cleaning occurs, the humidity level far exceeds normal industrial environments. In these situations, lubricants and other fluids stored in tanks and reservoirs need the protection of a desiccant breather even more. However, small temperature variations draw in the humid air and unnecessarily reduce the life of the breather. The Watchdog[®] EX Series Breathers for extreme humidity applications incorporate two check valves, one to control airflow into the protected reservoir and one to control airflow out. This prolongs the life of the desiccant by allowing the air to flow through the breather only when needed to protect the integrity of the tank. Unlike a membrane system, which does not allow internally generated gases and contaminants to exit the system, the Watchdog EX Breather offers all of the advantages of breathing air in and out of the tank while removing water vapor and solid particles before they contaminate the fluid.

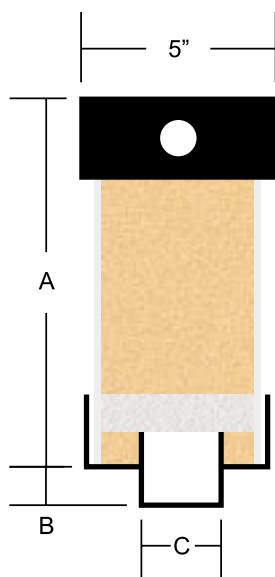

The reusable top cap contains the inlet and outlet valves which protect the silica gel from excess humidity.



The reusable top cap with inlet and outlet valves allows the economic replacement of the desiccant cartridge.

FEATURES:

- **Water Vapor Adsorbent** - longer lasting desiccant formulated specifically for maximum efficiency at humidity levels of 80% and higher.
- **Color Indicating** - When maximum adsorption is reached the silica gel turns from gold to dark green, indicating replacement is needed. The silica gel used is chemically inert, non-corrosive, and does not contain cobalt chloride, a heavy metal. The color changing dye used is environmentally safe and meets all health and safety requirements.
- **Durable Construction** - Watchdog Breathers are manufactured from rugged ABS plastic and impact modified acrylic.
- **Easy Connection** - Models are available with 1" slip fit connection which mates with the standard Watchdog Breather adapters or with a 2" male NPT connection.
- **Reusable Top Cap** - Allows the economic replacement of the desiccant cartridge.

SPECIFICATIONS

Nominal Air Flow Rate	35 CFM (250 gpm of fluid volume change)
Operating Temperature Range	-20°F to 200°F (-28°C to 93°C)
Material	ABS plastic and impact-modified acrylic
Particulate Filtration Level	2 Micron Filter

SELECTION CHART

Model No.	Dim A	Dim B	Dim C	Rate Airflow	Water Capacity	Check Valve Capacity
39111	5 in	1.25 in	1" slip	35 CFM	.6 lb	.3 psi in / 2.1 psi out
39112	8 in	1.25 in	1" slip	35 CFM	1.4 lb	.3 psi in / 2.1 psi out
39113	5 in	1.87 in	2" MNPT	35 CFM	.6 lb	.3 psi in / 2.1 psi out
39114	8 in	1.87 in	2" MNPT	35 CFM	1.4 lb	.3 psi in / 2.1 psi out

ACCESSORIES: Adapters are ordered separately, please see Watchdog Breathers Adapters document.

Watchdog[®] Breather Adapters

ADAPTER SELECTION

Watchdog desiccant breathers are easily installed using one of several adapters designed for different applications.

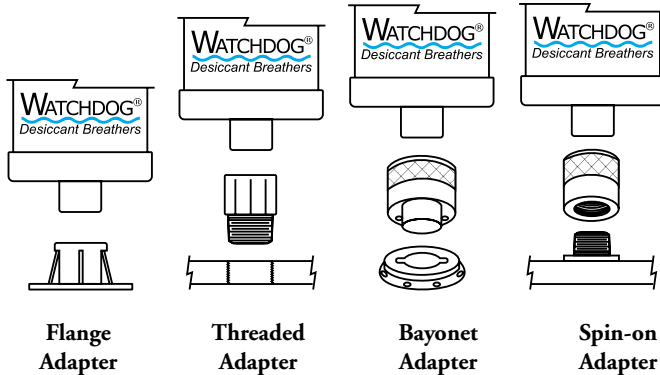

ADAPTER SELECTION CHART: (part numbers 39100, 39101, and 39102)

Model No.	Description
39200	Flange adapter, without mounting holes
39201	Flange adapter, with 6 ANSI mounting holes
39202	Threaded adapter, 1" NPT male x 1" slip fit
39203	Threaded adapter, 3/4" NPT male x 1" slip fit
39204	Bayonet adapter
39205	Spin-on adapter, 1"-12 UNF female x 1" slip fit
39206	Spin-on adapter, 1-1/2"-16 UNF female x 1" slip fit
39207	Bypass adapter
39216	Adapter, 1/2" NPT male x 1" slip fit

THE BYPASS ADAPTER

The Bypass Adapter is designed for applications where there is very heavy oil mist being expelled from the equipment.

When air is breathed into the equipment, it passes through the Watchdog[®] and is cleaned and dried. When the air is breathed out of the equipment it enters the adapter and is expelled to the outside without passing back through the breather. This protects the breather from oil contamination.



Bypass Adapter
(P/N 39207)

ADAPTER SELECTION CHART: (part numbers 39131, 39132, 39133 and 39134)

Illustration	Trico Part Number	T1	T2
	39208	1/2" NPT	1/4" NPT
	39210	1/2" NPT	3/8" NPT
	39212	1/2" NPT	1/2" NPT
	39213	1/2" NPT	3/4" NPT
	39215	1/2" NPT	1" NPT
	39209	1/4" NPT	1/2" NPT
	39211	3/8" NPT	1/2" NPT
	39214	3/4" NPT	1/2" NPT

WATCHDOG VAPOR SENTRY

Pumps, gearboxes, and some hydraulic reservoirs generate heavy oil mist, which is thrown up and out, or simply migrates, through the vent. This oil mist forms droplets of oil on the outside of the equipment creating an environmental issue, a safety issue, and ongoing clean-up procedures. If a desiccant breather is being used on the equipment, its useful life can be significantly shortened.

The Watchdog Vapor Sentry Oil Coalescing Breather solves these problems. The original breather or vent cap is removed and replaced with the Watchdog Vapor Sentry. The original breather is then reinstalled on top of the coalescing unit. The connection on top of the unit is a 1/2" MNPT which is designed to mate with the Watchdog Mini Desiccant Breathers. A simple screw-on adapter allows the use of the Watchdog slip-fits (39100, 39101, and 39102) or Watchdog EX Series breathers with the Watchdog Vapor Sentry.

ADAPTER SELECTION CHART:

Model No.	Description
39199	Vapor Sentry



Watchdog Oil Dryer

APPLICATIONS:

The WATCHDOG oil dryer is a non-vented system designed to remove water vapor from the air as it is drawn through a bed of silica gel. It is ideal for bearing housings and other applications where moisture condensation must be minimized. The compact design and standard thread size are designed to simplify installation. Equipment can be protected from internal moisture damage when the WATCHDOG Oil dryer is installed.

FEATURES:

- Desiccant cartridges change color to indicate when replacement is required.
- Cartridge replacement is simple and takes less than one minute.
- Multiple purpose - serves as a viewport, a fillport and an oil dryer.



SELECTION CHART

Model No.	Description
31807	1" NPT Polysulfone Oil Dryer with viewport
31808	1/2" NPT Polysulfone Oil Dryer without viewport
31848	1" NPT Metal/Glass Oil Dryer with viewport
31849	1" Metal/Glass Oil Dryer with viewport & wire guard

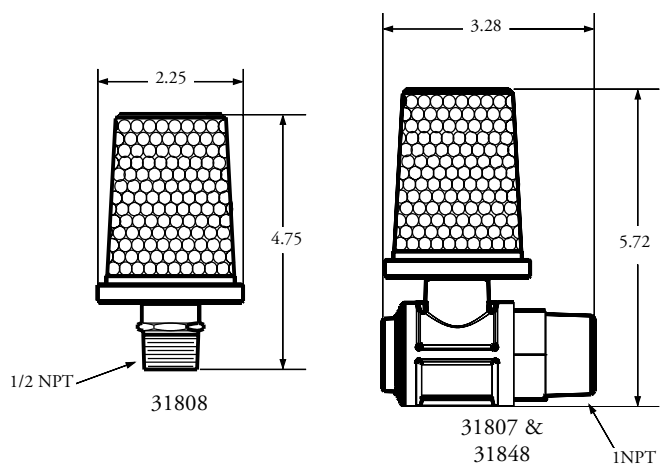

(NOTE: All dimensions are in inches.)

SPECIFICATIONS

Connections	31807	31808	31848 & 31849
Material	Polysulfone	Polysulfone	Glass & Aluminum
Max. Operating Temp.	325°F/160°C	325°F/160°C	325°F/ 160° C

REPLACEMENTS

Model No.	Description
21841R	Replacement cartridge for model numbers 31807 and 31808
31854	1 gal refill of desiccant

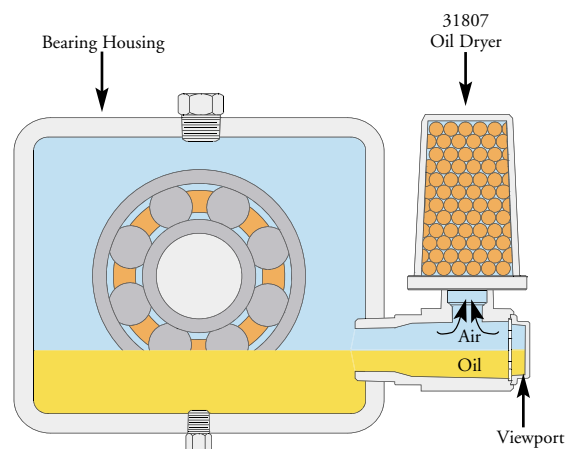

Portable Filtration Systems



In the past choices were very limited when it came to filtering lubricants with viscosities greater than 500 SUS @ 100°F. Now Trico offers a solution with our Filtration Systems. The problem with attempting to filter a high viscosity oil with a lower viscosity system is that the pump and filters are not designed to work with higher pressures required to push high viscosity fluids through the system. As a result these low viscosity units operate primarily in “bypass” mode where little if any of the high-viscosity oil gets filtered.

That is where Trico’s High-Viscosity Gear and Lube Oil Filtration Systems comes in. These systems are specifically designed for high-viscosity fluids associated mainly with gear oils and can filter oils up to 7500 SUS @ 100°F (1600 cSt @ 40°C).

SELECTION CHART

Model No.	Description
36955	Portable Cart System
36957	Hand-Held System
22467	Hose & Wand Assembly (optional)

FEATURES:

Hand-Held System

- **Differential Pressure Gauges** - Indicates when elements need to be changed
- **High Viscosity Oil Sampling Ports** - Two sampling ports available to monitor condition of oil
- **Dual Filters** - Two-stage filtration for long element life and pump protection
- **Compact Frame** - Lightweight design provides flexibility to service equipment located in hard to reach areas
- **Hoses** - Heavy-duty reinforced PVC and thermoplastic

Portable Cart System

- **Manual Bypass Valve** - Allows transfer of oil without filtering
- **High Viscosity Oil Sampling Ports** - Two sampling ports available to monitor condition of oil
- **Dual Filters** - Two-stage filtration for long element life and pump protection
- **Industrial Strength Pneumatic Tires** - Wide tires capable of getting over large grate gaps
- **Differential Pressure Gauges** - Indicates when elements need to be changed
- **Heavy Duty Cart** - Rugged and built to last
- **Hose & Wand Assembly (optional)** - Heavy steel wire reinforced clear PVC hoses with 3' long metal wands

Portable Filtration Systems

SPECIFICATIONS

	Hand-Held System	Portable Cart System
Pump Type	Industrial Grade Gear Pump	Industrial Grade Gear Pump
Flow Capacity	1 GPM	4 GPM
Gear Pump Speed	1725 RPM	1725 RPM
Maximum Inlet Vacuum	15" of Mercury	8" of Mercury
Hose Sizing @ 2ft/sec	.75" Inlet and .50" Outlet Dia @ 6' Long	1.25" Dia. @ 12' Long
Max. Operating Temperature	110°F Continuous - 150° Limited Use	110°F Continuous - 150° Limited Use
Pump By-Pass	75 psi	65 psi
Filter By-Pass	40 psi	40 psi
Maximum Viscosity	1600 cSt @ 40°C 7500 SUS @ 100°F ISO 1500 @ 40°C	1600 cSt @ 40°C 7500 SUS @ 100°F ISO 1500 @ 40°C
Seal and Gasket Material	Viton®	Viton®
Electrical Service Required*	115 Volts, 10 Amps, Single Phase, 60 Hz	115 Volts, 10 Amps, Single Phase, 60 Hz
Weight	40 lbs	125 lbs
Dimensions	27"W x 13"D x 17"H	28"W x 21"L x 48"H

*220 Available

HAND-HELD FILTER MEDIA (SPIN-ON)

	36963	36965	36966	36964	36967
Filter Media	Cellulose	Cellulose	Cellulose	Micro-Glass	Cellulose
Filter Type	Particulate	Particulate	Particulate	Particulate	Water
Diameter	3.7"	3.7"	3.7"	3.7"	3.7"
Length	8.6"	8.6"	8.6"	8.6"	8.6"
Thread	1-12	1-12	1-12	1-12	1-12
Micron Rating	3	10	25	10	3
Beta Ratio	Beta 3 = 4	Beta 10 = 2	Beta 25 = 2	Beta 12 = 75	Beta 5 = 4
Dirt Holding Capacity	36 grams	37 grams	60 grams	50 grams	18 grams
Water Holding Capacity	N/A	N/A	N/A	N/A	14 grams

PORTABLE FILTER CART MEDIA (CARTRIDGES)

	36958	36960	36961	36959	36962
Filter Media	Cellulose	Cellulose	Cellulose	Micro-Glass	Cellulose
Filter Type	Particulate	Particulate	Particulate	Particulate	Water
Diameter	4.5"	4.5"	4.5"	4.5"	4.5"
Length	18"	18"	18"	18"	18"
Media ft ²	20	20	20	10.5	N/A
Micron Rating	5	10	25	5	10
Beta Ratio	5 micron nominal	10 micron nominal	30 micron nominal	Beta 5 ≥ 200	-
Dirt Holding Capacity	1000 grams	1000 grams	900 grams	950 grams	N/A
Water Holding Capacity	N/A	N/A	N/A	N/A	1.1 to 2.4 liters*

*Based on flow rate and viscosity

Introduction to Fluid Handling Systems

Lubricants are frequently topped off or replaced in harsh conditions, where the potential for contamination from dust, dirt, and water is the greatest. Unfortunately, the choice of a container to store, dispense and transfer the lubricant to the machinery is often questionable. Quite often these containers range from modified open topped coffee cans, jugs, buckets, and even old watering containers. These containers provide no protection to the lubricant from airborne contaminants. Below is a list of some important features to look for when selecting a fluid handling system.

- **Ruggedness** - Fluid handling containers need to be tough enough to endure being tossed, slammed, dropped, and bumped.
- **Closeable** - Being able to close the fluid handling container tight is essential to keeping the lubricants clean. If the container is unable to be closed, there is no assurance that contamination will be controlled.
- **Easy to handle** - Fluid handling containers should be comfortable enough for personnel to carry through out the facility when full of oil.
- **No funnels** - Funnels are a huge contamination risk because they are hard to clean, and are usually used with a variety of lubricants. They are also stored in areas where they are exposed to dirt and other contaminants. The ideal fluid handling container is designed with a pour spout that eliminates the need for a funnel.
- **Lubricant identity** - Fluid handling containers should have an identifier for indicating the type of fluid within the container. Identifiers can come in the form of color, shape, size, or tags.
- **Non-reactive** - Some lubricant additives can interact with specific materials that some fluid handling containers are manufactured with. Plastics or stainless steel are the most desirable materials available.
- **Cleanable** - At some point in time the fluid handling container may need to be cleaned. The container should be designed to facilitate easy cleaning to ensure effective contamination control.
- **Pumping option** - In some areas where access is limited, pouring oil from a fluid handling container is not possible. In this case, the container should easily adapt to a pump that will allow the lubricant to flow effectively into the equipment.

Contamination is the root cause to lubricant degradation and machinery failure. It must be managed to assure proper performance. The selection of a fluid handling system is fundamental to the success of effectively and efficiently delivering clean lubricants to the machinery.



Open top can used for filling oil sumps can be a source of contamination.



Proper fluid handling system



Improper fluid handling methods

Oil Safe® Products



Oil Safe® products provide a safe, easy method of transporting, handling, and dispensing lubricating fluids in a wide variety of applications. These products are durable and built with High Density Polyethylene (HDPE) to perform in hostile environments. Ultra-violet and anti-static agents have been added to protect the product from ultra-violet degradation and the accumulation of static electricity. The product lids and drums are interchangeable and come in a variety of sizes and styles to suit individual needs. Lids are available in ten colors – yellow, red, blue, green, purple, orange, black, dark green, tan, and gray for easy identification of fluid type.

SPECIFICATIONS

O-ring	Buna-N
Temperature Range	-40°F to 176°F
Material	High Density Polyethylene
Additives	UV stabilizers and anti-statics

NOT SUITABLE FOR USE WITH FUELS OR SOLVENTS



PRODUCT SELECTION:

STORAGE LID

This compact and durable lid allows pre-filled drums to be easily transported and stored.



UTILITY LID

This multi-purpose lid allows for rapid pouring of oils, making it ideal for topping off machinery such as crankcases or large engine blocks. Outlet hole on utility lid is 50mm. Fitting an Oil Safe® Pump to the Utility Lid will allow oil to be pumped out of 3, 5, or 10 liter drum.



STRETCH SPOUT LID

Ideal for use with lower viscosity oils or where precise pouring is required. For precision pouring applications involving oil viscosity grades of ISO 220 or less. Spout valve has a 12mm outlet hole.



STUMPY SPOUT LID

Ideal for topping off engines, crankcases, and other applications where higher flow is required. Spout valve has a 24mm outlet hole.



MINI SPOUT LID

The Mini Spout Lid has an outlet diameter of approximately 7mm, making it ideal for controlled pouring into small reservoirs or filler holes.

DRUMS – 1.5, 2, 3, 5, & 10 L

These robust and durable drums feature a wide opening for rapid no spill filling, easy cleaning and will fit any lid.



OIL SAFE® PUMP

Ideal for those awkward and hard to reach oil top off applications such as motorcycles, gearboxes, lathes and milling machines. Supplied with outlet hose and anti-drip nozzle. The Oil Safe® pump delivers 1 liter for approximately every 14 strokes. Simply fit the pump to a Utility Lid and mate with a 3, 5, or 10 liter drum. For small reservoirs and filler holes an optional pump reducer nozzle is available that slides over Oil Safe® pump nozzle. Reduces from 3/8" OD - 1/4" ID.



SPOUT HOSE EXTENSIONS

Fitting a Stretch or Stumpy Spout Hose Extension, will enable controlled pouring into awkward or hard to reach places. The hose can be pulled from the fitting and cut to length as required.



SELECTION CHART - Lids

Description	Yellow	Red	Blue	Green	Purple	Dark Green	Black	Orange	Tan	Gray
Storage Lid	31872	31881	31882	31883	31887	31884	31885	31886	31919	31918
Utility Lid	31873	31888	31889	31890	31894	31891	31892	31893	31921	31920
Stretch Spout Lid	31871	31895	31896	31897	31901	31898	31899	31900	31923	31922
Stumpy Spout Lid	31870	31902	31903	31904	31908	31905	31906	31907	31927	31926
Mini Spout Lid	31909	31910	31911	31912	31916	31913	31914	31915	31925	31924

SELECTION CHART

Description	Model No.
1.5 Liter Drum	31928
2 Liter Drum	31877
3 Liter Drum	31878
5 Liter Drum	31879
10 Liter Drum	31880
Oil Safe® Pump	31874
Stretch Spout Hose Extension	31876
Stumpy Spout Hose Extension	31875
Pump Reducer Nozzle	31917

Oil Safe® Products

FEATURES:

Spout valve regulates oil flow and reduces oil contamination due to rain, sand, and dust entering through open spouts

Nozzles twist close to reduce contamination

Lids available in ten colors – yellow, red, blue, green, purple, orange, black, dark green, tan, and gray for easy identification of fluid type



Drum label included to provide easy identification of lubricant type

All lids and drums are interchangeable

Large carry handle, which doubles up as a hook so drums can be hung up out of the way

Convolute drum profile and large inlet hole allows for easy grip when filling

High heat and chemical resistance with ultra-violet and anti-static additives

See through graduated drums make liquid levels easy to see and measure



MANUFACTURED FOR TRICO MFG. CORP.
 UNDER CO-BRANDING AGREEMENT.
 OIL SAFE® IS A REGISTERED TRADEMARK OF
 OIL SAFE SYSTEMS PTY. LTD.



Buna-N o-ring seals lubricant from the external environment



Wide range of spouts, hoses, and nozzles allow easy filling to awkward points

Introduction to Gravity Feed Oilers

The purpose of gravity feed lubrication is to provide a reliable and continuous supply of oil to bearings, gears, chains, and other rotating or moving machinery components. As the name applies, these systems operate using gravity feed principle. A supply reservoir is used to feed lubricant through piping, by means of gravity, to the point of lubrication. These systems can also consist of a number of manifolds or distribution centers from which oil is directly piped to the surface to be lubricated. Each point has its own independent piping and set of connections. Gravity feed lubrication is an alternate means of lubricating machinery components rather than using automatic systems such as centralized lubrication. The method of employing gravity feed lubrication consists of drip-feed, chain, and wick feed lubrication.

Drip-feed Oilers: A drip-feed oiler consists of a simple reservoir mounted in a convenient position for filling, while allowing the piping to be connected to the point of lubrication. Typically the rate of feed, to each lubrication point, is regulated by a needle valve, which is manually adjustable. In addition, manifolds can be used with drip-feed oilers to supply lubricant to multiple points.

Chain Oilers: Chain oilers automatically apply a film of lubricant to chains, gears, slides, irregular surfaces or out-of-the-way oscillating parts. They greatly reduce link wear, stretch, friction, rust, and corrosion. Chain oilers are similar in operation to drip-feed oilers however; they contain an applicator to supply lubricant to the source. Applicators are available in a variety of styles for both lubricating and cleaning purposes of the chain.

Wick Feeds Oilers: Wick feed oilers combine gravity feed with capillary action to provide a constant rate of oil to the lubricating point, regardless of fluid level in the reservoir. The capillary action is provided by the use of various wick sizes. The rate of feed is adjusted with the use of different wick sizes or viscosity of oil.

Gravity feed oilers bring the benefits of automatic lubrication without the high cost. They provide a simplistic, yet reliable method, of keeping component parts of industrial machinery lubricated. Trico offers a wide range of gravity feed oilers for lubricating single or multiple points and for use in conjunction with brush applicators.



Chain oiler lubricating a chain on a trommel screen.

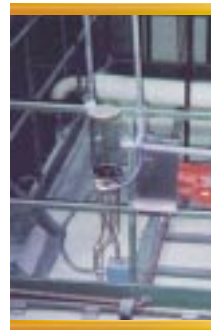

Gravity feed oiler on drying machine.



Gravity feed oilers on a mud washing drum.

Gravity Feed Oilers

APPLICATIONS:

The gravity feed oilers work in a wide range of industrial lubricating applications. The rate of oil feed is adjustable and a lock ring maintains the setting. In bearing or gear lubrication, the gravity feed oilers provide dependable lubrication in the most demanding environments.

FEATURES:

- Three position toggle switch provides easy to use on-off control, and a flushing option to avoid dry start-ups.
- Vented sight chamber ensures proper operation when used with tight or high speed bearings.
- Copper brazing of all steel connections provides long life and leak proof design.



37016

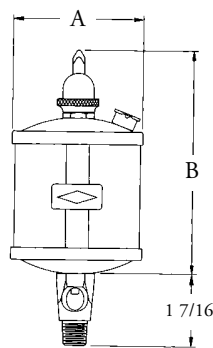

KG

KG

- Heavy wall glass reservoirs and sight chambers operate continuously at 250°F.
- Nickel plating offers superior corrosion resistance.

KL

- Plastic reservoirs have reinforced ribs for long life and impact resistance.
- Zinc plating resists corrosion.



30325

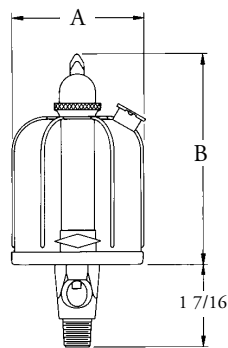

KL

SPECIFICATIONS - KG

Max. Operating Temp.	250°F Continuous
Reservoir	Heavy Wall Heat Resistant Glass
Oil Sight	Heavy Wall Heat Resistant Glass
Gaskets	Buna-N
Materials	Heavy Gauge Steel
Finish	Bright Nickel Plate
Needle Valve	Steel

SELECTION CHART - KG

Model No.	Capacity	Connection (NPT)	Dimensions (in.)	
			A	B
37011	1 oz.	1/8	1-5/8	3-1/4
37012	1 oz.	1/4	1-5/8	3-1/4
37013	2.5 oz.	1/8	2-1/8	4
37014	2.5 oz.	1/4	2-1/8	4
37015	5 oz.	1/8	2-5/8	4-5/8
37016	5 oz.	1/4	2-5/8	4-5/8
37017	5 oz.	3/8	2-5/8	4-5/8
37018	10 oz.	1/4	3-1/8	5-3/8
37019	10 oz.	3/8	3-1/8	5-3/8

SPECIFICATIONS - KL

Max. Operating Temp.	165°F Continuous
Reservoir	Butyrate Plastic
Oil Sight	Acrylic Plastic
Sight Gaskets	Buna-N
Materials	Steel and Brass
Finish	Bright Zinc Plated
Needle Valve	Steel

SELECTION CHART - KL

Model No.	Capacity	Connection (NPT)	Dimensions (in.)	
			A	B
30320	1 oz.	1/8	1-5/8	2-5/8
30321	1 oz.	1/4	1-5/8	2-5/8
30322	2 oz.	1/8	1-15/16	3-1/16
30323	2 oz.	1/4	1-15/16	3-1/16
30324	4 oz.	1/8	2-5/16	3-7/8
30325	4 oz.	1/4	2-5/16	3-7/8
30326	4 oz.	3/8	2-5/16	3-7/8
30327	8 oz.	1/8	2-5/8	4-15/16
30328	8 oz.	1/4	2-5/8	4-15/16
30329	8 oz.	3/8	2-5/8	4-15/16

Atlas Gravity Feed Oilers

APPLICATIONS:

The Atlas gravity feed oiler is used in heavy-duty applications where a large oil capacity is needed and an adjustable rate of oil is required. Silver brazed construction of the reinforced brass assembly provides long life in high vibration applications.

The Atlas oiler is adjustable for varying rates of oil flow used in bearing or machinery lubrication. The adjustable drip rates are easily set and controlled with a lock ring for maximum versatility.

FEATURES:

- Heavy wall heat resistant glass reservoirs and sights providing service in temperatures to 250°F.
- Acrylic reservoir versions have heavy walls for long life in applications to 165°F.
- Three position toggle switch provides easy to use on-off control, and a flushing option to avoid dry start-ups.
- Direct mounting with NPT threads (AL) or remote mounting with 3/4-16 mounting stud and 1/4" tubing connections (ACL) simplifies installation.
- Silver brazing of all brass construction provides long life and leak proof design.
- Clear lacquer finish resists corrosion.

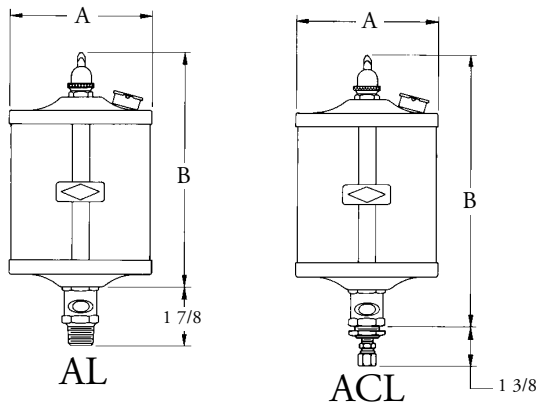

SPECIFICATIONS

Max. Operating Temp.	Glass 250°F Continuous Acrylic 165°F Continuous
Reservoir	Heavy Wall Heat Resistant Glass Heavy Wall Acrylic Plastic
Oil Sight	Heavy Wall Heat Resistant Glass Heavy Wall Acrylic Plastic
Gasket	Buna-N
Material	Brass
Finish	Lacquered Satin Finish
Needle Valve	Brass

SELECTION CHART - AL

Locking Ring Mechanism - Direct Mounting

Model No.		Capacity	Connection (NPT)	Dimensions (in.)	
Glass	Acrylic			A	B
31511	31410	10 oz.	1/4	3-1/8	5-9/16
31512	31411	10 oz.	3/8	3-1/8	5-9/16
31517	31416	1 pt.	3/8	3-5/8	6-9/16
31518	31417	1 pt.	1/2	3-5/8	6-9/16
31543	31432	1 qt.	1/2	4-7/16	7-5/8
31581	31480	2.5 qt.	1/2	5-11/16	9-3/4
-	31481	1 gal.	1/2	5-11/16	14-13/16

SELECTION CHART - ACL

Locking Ring Mechanism - Remote Mounting - 1/4" tube connector furnished.

Model No.		Capacity	Mounting Stud	Dimensions (in.)	
Glass	Acrylic			A	B
32111	32010	10 oz.	3/4-16	3-1/8	6-5/8
32117	32016	1 pt.	3/4-16	3-5/8	7-5/8
32133	32032	1 qt.	3/4-16	4-7/16	8-11/16
32181	32080	2.5 qt.	3/4-16	5-11/16	10-13/16
-	32081	1 gal.	3/4-16	5-11/16	15-7/8

PC Oil Cup

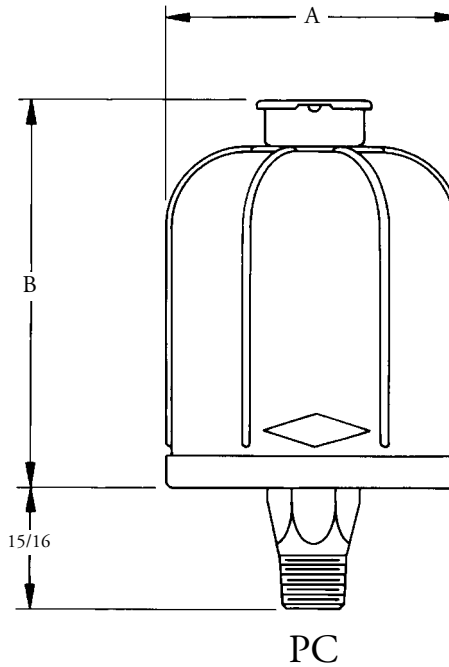
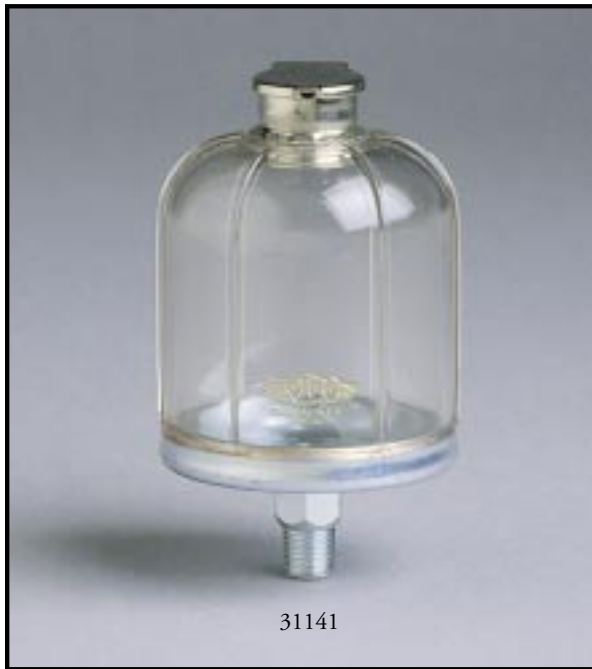

APPLICATIONS:

PC oil cups serve a dual purpose of providing a small oil reservoir or being used as an oil gauge. The PC oil cup is ideal for applications where it can be directly mounted to a bearing housing, gear box or any other industrial equipment that requires lubricant.

FEATURES:

- Dust proof, self-closing fill caps supplied with all models.
- Plastic reservoirs have reinforcing ribs for long life and impact resistance.
- Copper brazing of all steel connections provides long life and leak proof design.
- Zinc plating resists corrosion.

SPECIFICATIONS

Max. Operating Temp.	165°F Continuous
Reservoir	Butyrate Plastic
Material	Steel
Finish	Bright Zinc Plated

SELECTION CHART

Model No.	Capacity	Connection (NPT)	Dimensions (in.)	
			A	B
31111	1 oz.	1/8	1-5/8	1-5/8
31112	1 oz.	1/4	1-5/8	1-5/8
31121	2 oz.	1/8	1-15/16	2-5/16
31122	2 oz.	1/4	1-15/16	2-5/16
31141	4 oz.	1/8	2-5/16	3
31142	4 oz.	1/4	2-5/16	3
31143	4 oz.	3/8	2-5/16	3
31181	8 oz.	1/8	2-5/8	4
31182	8 oz.	1/4	2-5/8	4
31183	8 oz.	3/8	2-5/8	4

Vari-Feed Wick Oilers



SPECIFICATIONS

Max. Operating Temp.	165°F Continuous
Reservoir	Butyrate Plastic
Oil Sight	Acrylic
Sight Gaskets	Buna-N
Wicking	Wire Cored Cotton
Material	Steel and Brass
Finish	Bright Zinc Plated

APPLICATIONS:

Vari-Feed wick oilers are used to provide a controlled amount of oil to a bearing or other machinery part. The principle of delivery combines gravity feed with capillary action in the wick to provide a constant feed rate of oil regardless of the fill level in the reservoir. Feed rate is determined by the viscosity of the oil and the type of wick being used.

Two styles of operation are available depending on the application. When continuous delivery is required the N or NS models are used.

For on-off control of the oiler, the NA and NAS models have a filler cap with gasket that stops oil delivery when fully closed. By turning the fill cap slightly, the threaded air vent is opened allowing oil to flow.

FEATURES:

- Feed rate is constant and adjustable only by changing to a different wick.
- 5 wick speeds are available and color coded for easy replacement or installation. A multi-pack of different wick speeds is included with each oiler.
- Dust proof caps supplied with N and NS models. NA and NAS models have sealed cap and operate only when cap is in vent position.
- Plastic reservoirs have reinforcing ribs for long life.
- Oil sights available on NS and NAS models for visual indication of oil flow.
- Copper brazing of all steel connections provides long life and leak proof design.
- Zinc plating resists corrosion.

SELECTION CHART - N, NS

Model No.		Capacity	Connection (NPT)	Dimensions (in.)	
Type N	Type NS			A	B
30711	30811	1 oz.	1/8	1-5/8	1-5/8
30712	30812	1 oz.	1/4	1-5/8	1-5/8
30721	30821	2 oz.	1/8	1-15/16	2-5/16
30722	30822	2 oz.	1/4	1-15/16	2-5/16
30741	30841	4 oz.	1/8	2-5/16	3
30742	30842	4 oz.	1/4	2-5/16	3
30743	30843	4 oz.	3/8	2-5/16	3
30781	30881	8 oz.	1/8	2-5/8	4
30782	30882	8 oz.	1/4	2-5/8	4
30783	30883	8 oz.	3/8	2-5/8	4

SELECTION CHART - NA, NAS

Model No.		Capacity	Connection (NPT)	Dimensions (in.)	
Type NA	Type NAS			A	B
30911	31011	1 oz.	1/8	1-5/8	2
30912	31012	1 oz.	1/4	1-5/8	2
30921	31021	2 oz.	1/8	1-15/16	2-7/16
30922	31022	2 oz.	1/4	1-15/16	2-7/16
30941	31041	4 oz.	1/8	2-5/16	3-1/4
30942	31042	4 oz.	1/4	2-5/16	3-1/4
30943	-	4 oz.	3/8	2-5/16	3-1/4
30981	31081	8 oz.	1/8	2-5/8	4-5/16
30982	31082	8 oz.	1/4	2-5/8	4-5/16
30983	31083	8 oz.	3/8	2-5/8	4-5/16

Replacement Wicks

Packed 50 of one color per carton. Also sold by the foot.

	Model No.	Length	Description
	30701	1-3/8"	White - Very Fast Feed Wick
	30702		Green/White - Fast Feed Wick
	30703		Green - Medium Feed Wick
	30704		Red/White - Slow Feed Wick
	30705		Red - Very Slow Feed Wick

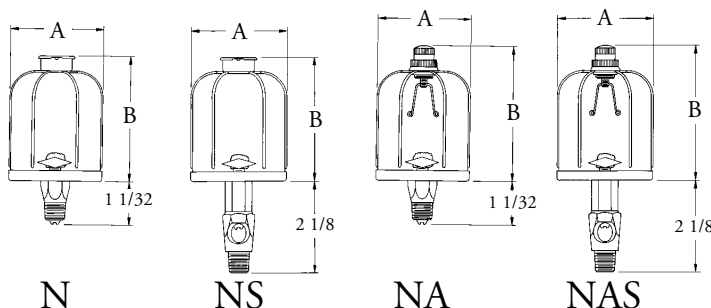

CA & CAE Chain Oilers

APPLICATIONS:

CA and CAE chain oilers are designed for light duty lubrication of small chains. They operate on a gravity feed principle supplying an adjustable amount of oil through an applicator to the chain.

In applications requiring automatic control of the oiler, solenoid versions are available.

FEATURES:

- Toggle shut-off with locking ring (CA model) provides easy to use manual control.
- Solenoid version (CAE model) allows machine interface for maximum versatility.
- Plastic reservoirs have reinforcing ribs for long life.
- Adjustable adapter allows easy setting of applicator to correct height.
- Brazed construction provides long life and leak proof design.

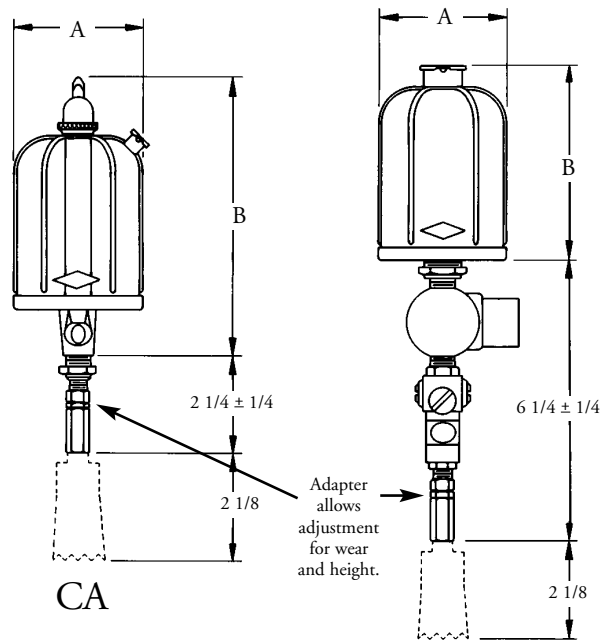

SOLENOID VOLTAGE

Designator	Voltage
B	120V 60 Hz
C	240V 60 Hz
D	480V 60 Hz

HOW TO ORDER: Using the solenoid voltage chart, add a "B", "C", or "D" to the model number to specify the correct voltage on solenoid versions.

SPECIFICATIONS

Max. Operating Temp.	165°F Continuous
Reservoir	Butyrate Plastic
Oil Sight	Acrylic Plastic
Sight Gasket	Buna-N
Material	Steel and Brass
Finish	Bright Zinc Plated Steel Lacquered Satin Finish Brass
"CA" Needle Valve	Steel
"CAE" Sight Needle Valve	Brass
"CAE" Packing Gland	Graphite
Solenoid - UL/CSA Listed	Stainless Steel/Brass

SELECTION CHART - CA

Manual Control

Model No.	Capacity	Mounting Stud	Dimensions (in.)	
			A	B
35503	4 oz.	1/2-20	2-5/16	4-3/4
35504	8 oz.	1/2-20	2-5/8	5-3/4

SELECTION CHART - CAE

Electric Solenoid Control - See "How to Order"

Model No.	Capacity	Mounting Stud	Dimensions (in.)	
			A	B
35505	4 oz.	3/4-16	2-5/16	3
35506	8 oz.	3/4-16	2-5/8	4

ACCESSORIES: Applicators are ordered separately, please see Applicator document.

CB & CBE Chain Oilers



APPLICATIONS:

CB and CBE chain oilers are designed for nearly all types of chain lubrication. They operate on a gravity feed principle supplying a pre-set amount of oil through an applicator to the chain. With heavy wall acrylic or heat resistant glass reservoirs, and all brass construction, they operate in a wide range of applications. In applications requiring automatic control of the oiler, solenoid versions are available.

FEATURES:

- Toggle shut-off with locking ring (CB model) provides easy to use manual control.
- Solenoid version (CBE model) allows machine interface for maximum versatility.
- Mounting stud simplifies installation to customer supplied bracket.
- Acrylic reservoirs are heavy wall design for service to 165°F. Heat resistant glass reservoirs operate in temperatures to 250°F.
- Adjustable adapter allows easy setting of applicator to correct height.
- Silver brazing of all brass construction provides long life and leak proof design.
- Clear lacquer finish of brass components resist corrosion.

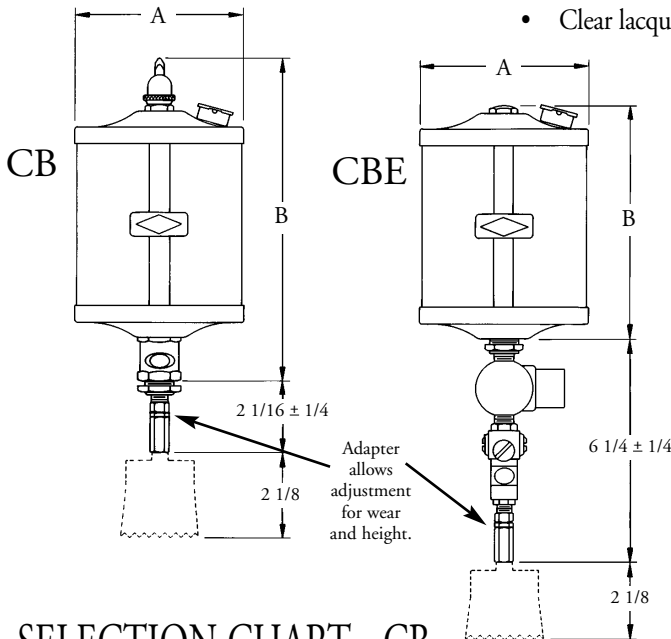

SPECIFICATIONS

Max. Operating Temp.	Glass 250°F Continuous Acrylic 165°F Continuous
Reservoir and Sight	Heavy Wall Heat Resistant Glass Heavy Wall Acrylic Plastic
Gasket	Buna-N
Material	Brass
Finish	Lacquered Satin Finish
"CB" Needle Valve	Brass
"CBE" Sight Needle Valve	Brass
Solenoid	Stainless Steel Plunger, Brass Body UL/CSA Listed

SELECTION CHART - CB

Manual Control

Model No.		Capacity	Mounting Stud	Dimensions (in.)	
Glass	Acrylic			A	B
35512	35513	10 oz.	3/4-16	3-1/8	6-1/2
35514	35515	1 pt.	3/4-16	3-5/8	7-9/16
35516	35517	1 qt.	3/4-16	4-7/16	8-9/16
35518	35519	2.5 qt.	3/4-16	5-11/16	10-3/4
-	35520	1 gal.	3/4-16	5-11/16	15-3/4

SOLENOID VOLTAGE

Designator	Voltage
B	120V 60 Hz
C	240V 60 Hz
D	480V 60 Hz

HOW TO ORDER: Using the solenoid voltage chart, add a "B", "C", or "D" to the model number to specify the correct voltage on solenoid versions.

Other Voltages and Frequencies Available. Consult Factory.

SELECTION CHART - CBE

Electric Solenoid Control - See "How to Order"

Model No.		Capacity	Mounting Stud	Dimensions (in.)	
Glass	Acrylic			A	B
35526	35527	10 oz.	3/4-16	3-1/8	4-1/16
35528	35529	1 pt.	3/4-16	3-5/8	5-3/16
35530	35531	1 qt.	3/4-16	4-7/16	6-3/16
35532	35533	2.5 qt.	3/4-16	5-11/16	8-5/16
-	35535	1 gal.	3/4-16	5-11/16	13-5/16



ACCESSORIES:

Applicators are ordered separately, please see Applicator document.

CC & CCE Chain Oilers



APPLICATIONS:

CC and CCE chain oilers are designed for chain lubrication on wide or ganged chains up to 4 inches. They operate on a gravity feed principle supplying a pre-set amount of oil through an applicator to the chain. With heavy wall acrylic or heat resistant glass reservoirs, and all brass construction, they operate in a wide range of applications.

In applications requiring automatic control of the oiler, solenoid versions are available.

FEATURES:

- Toggle shut-off (CC model) provides easy to use manual control.
- Solenoid version (CCE model) allows machine interface for maximum versatility.
- Mounting stud simplifies installation to customer supplied bracket.
- Acrylic reservoirs are heavy wall design for service to 165°F. Heat resistant glass reservoirs operate in temperatures to 250°F.
- Adjustable adapter allows easy setting of applicator to correct height.
- Silver brazing of all brass construction provides long life and leak proof design.
- Clear lacquer finish of brass components resists corrosion.

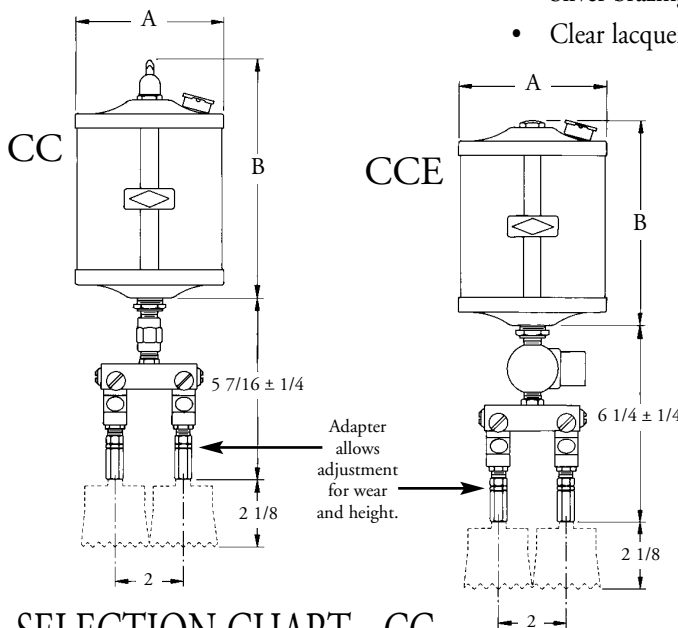

SPECIFICATIONS

Max. Operating Temp.	Glass 250°F Continuous Acrylic 165°F Continuous
Reservoir and Sight	Heavy Wall Heat Resistant Glass Heavy Wall Acrylic Plastic
Gasket	Buna-N
Material	Brass
Finish	Lacquered Satin Finish
Packing Gland	Graphite
Sight Needle Valve	Brass
Solenoid	Stainless Steel Plunger Brass Body, UL/CSA Listed

SELECTION CHART - CC

Manual Control

Model No.		Capacity	Mounting Stud	Dimensions (in.)	
Glass	Acrylic			A	B
-	35541	10 oz.	3/4-16	3-1/8	5-1/16
35542	35543	1 pt.	3/4-16	3-5/8	6-3/16
35544	35545	1 qt.	3/4-16	4-7/16	7-3/16
35546	35547	2.5 qt.	3/4-16	5-11/16	9-5/16
-	35549	1 gal.	3/4-16	5-11/16	14-5/16

SELECTION CHART - CCE

Electric Solenoid Control - See "How to Order"

Model No.		Capacity	Mounting Stud	Dimensions (in.)	
Glass	Acrylic			A	B
35550	35551	10 oz.	3/4-16	3-1/8	4-1/16
35552	35553	1 pt.	3/4-16	3-5/8	5-3/16
35554	35555	1 qt.	3/4-16	4-7/16	6-3/16
35556	35557	2.5 qt.	3/4-16	5-11/16	8-5/16
-	35559	1 gal.	3/4-16	5-11/16	13-5/16

SOLENOID VOLTAGE

Designator	Voltage
B	120V 60 Hz
C	240V 60 Hz
D	480V 60 Hz

HOW TO ORDER: Using the solenoid voltage chart, add a "B", "C", or "D" to the model number to specify the correct voltage on solenoid versions.

Other Voltages and Frequencies Available. Consult Factory.



ACCESSORIES:

Applicators are ordered separately, please see Applicator document.

D & DE Full Flow Dispensers

APPLICATIONS:

Trico full flow dispensers are used to lubricate bearings, chains, and other machinery parts when remote valves or manifolds are used. This allows for easy access to the oil reservoir when the valve or manifold is located in a difficult to reach spot. These dispensers are also used in applications where multiple point lubrication is required from one reservoir of oil. With heavy wall acrylic or heat resistant glass reservoirs, and all brass construction, they operate in a wide range of applications. In applications requiring automatic control of the oiler, solenoid versions are available.

FEATURES:

- Toggle shut-off (D model) provides easy to use manual control.
- Solenoid version (DE model) allows machine interface for maximum versatility.
- Mounting stud simplifies installation to customer supplied bracket.
- Acrylic reservoirs are heavy wall design for service to 165°F. Heat resistant glass reservoirs operate in temperatures to 250°F.
- Silver brazing of all brass construction provides long life and leak proof design.
- Clear lacquer finish of brass components resists corrosion.

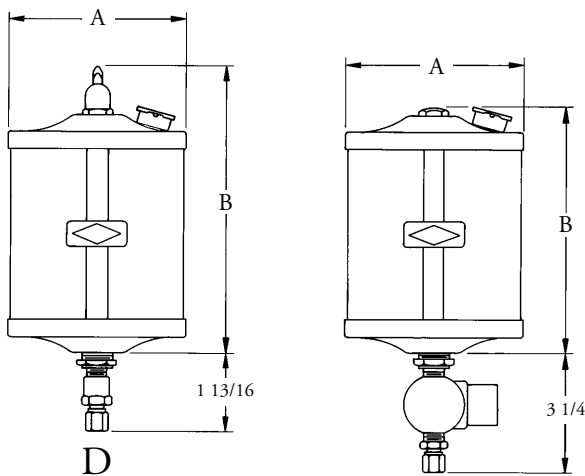

SPECIFICATIONS

Max. Operating Temp.	Glass 250°F Continuous Acrylic 165°F Continuous
Reservoir	Heavy Wall Heat Resistant Glass Heavy Wall Acrylic Plastic
Gasket	Buna-N
Material	Brass
Finish	Lacquered Satin Finish
Solenoid	Stainless Steel Plunger and Brass Body UL/CSA Listed
Needle Valve	Brass

SELECTION CHART - D

Manual Control - 1/4 Tube Connector Furnished.

Model No.		Capacity	Mounting Stud	Dimensions (in.)	
Glass	Acrylic			A	B
35560	35561	10 oz.	3/4-16	3-1/8	5-1/16
35562	35563	1 pt.	3/4-16	3-5/8	6-3/16
35564	35565	1 qt.	3/4-16	4-7/16	7-3/16
35566	35567	2.5 qt.	3/4-16	5-11/16	9-5/16
-	35569	1 gal.	3/4-16	5-11/16	14-5/16

DE

SELECTION CHART - DE

Electric Control - 1/4 Tube Connector Furnished. - See "How to Order"

Model No.		Capacity	Mounting Stud	Dimensions (in.)	
Glass	Acrylic			A	B
35570	35571	10 oz.	3/4-16	3-1/8	4-1/16
35572	35573	1 pt.	3/4-16	3-5/8	5-3/16
35574	35575	1 qt.	3/4-16	4-7/16	6-3/16
35576	35577	2.5 qt.	3/4-16	5-11/16	8-5/16
-	35579	1 gal.	3/4-16	5-11/16	13-5/16

SOLENOID VOLTAGE

Designator	Voltage
B	120V 60 Hz
C	240V 60 Hz
D	480V 60 Hz

HOW TO ORDER: Using the solenoid voltage chart, add a "B", "C", or "D" to the model number to specify the correct voltage on solenoid versions.

Other Voltages and Frequencies Available. Consult Factory.

ACCESSORIES:

V series valves and VM manifolds are ordered separately, please see V series valves and VM manifolds document.

Applicators are ordered separately, please see Applicator document.

E & EE Multiple Feed Oilers



APPLICATIONS:

Trico E and EE multiple feed oilers are used to lubricate bearings, chains, and other machinery parts when feed rate adjustment is desired at the dispenser. This allows for easy adjustment when the manifold or lubrication point is located in a difficult to reach spot. With up to 6 outlets, these oilers are also used in applications where multiple point lubrication is required from one reservoir of oil. With heavy wall acrylic or heat resistant glass reservoirs, and all brass construction, they operate in a wide range of applications.

In applications requiring automatic control of the oiler, solenoid versions are available.

FEATURES:

- Toggle shut-off (E model) provides easy to use manual control.
- Solenoid version (EE model) allows machine interface for maximum versatility.
- 3/4-16 mounting stud and 1/4 in. tubing connector simplifies installation to customer supplied bracket.
- Acrylic reservoirs are heavy wall design for service to 165°F. Heat resistant glass reservoirs operate in temperatures to 250°F.
- Silver brazing of all brass construction provides long life and leak proof design.
- Clear lacquer finish of brass components resists corrosion.

SPECIFICATIONS

Max. Operating Temp.	Glass 250°F Continuous Acrylic 165°F Continuous
Reservoir	Heavy Wall Heat Resistant Glass Heavy Wall Acrylic Plastic
Gasket	Buna-N
Packing Gland	Graphite
Material	Brass
Finish	Lacquered Satin Finish
Solenoid	Stainless Steel Plunger and Brass Body UL/CSA Listed
Sight Needle Valve	Brass

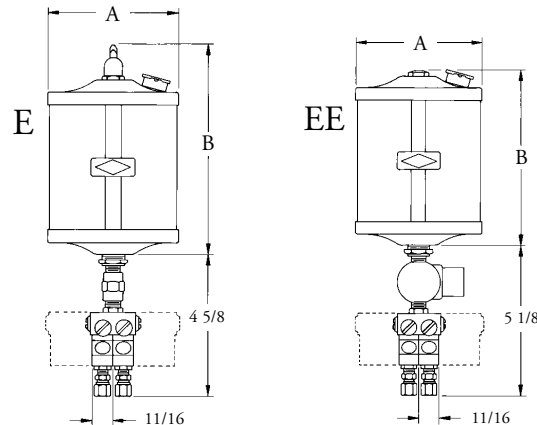

SELECTION CHART - E

Manual Control

Model No.		Capacity	Mounting Stud	Dimensions (in.)	
Glass	Acrylic			A	B
36000	36001	10 oz.	3/4-16	3-1/8	5-1/16
36002	36003	1 pt.	3/4-16	3-5/8	6-3/16
36004	36005	1 qt.	3/4-16	4-7/16	7-3/16
36006	36007	2.5 qt.	3/4-16	5-11/16	9-5/16
-	36009	1 gal.	3/4-16	5-11/16	14-5/16

SELECTION CHART - EE

Electric Solenoid Control - See "How to Order"

Model No.		Capacity	Mounting Stud	Dimensions (in.)	
Glass	Acrylic			A	B
36010	36011	10 oz.	3/4-16	3-1/8	4-1/16
36012	36013	1 pt.	3/4-16	3-5/8	5-3/16
36014	36015	1 qt.	3/4-16	4-7/16	6-3/16
36016	36017	2.5 qt.	3/4-16	5-11/16	8-5/16
-	36019	1 gal.	3/4-16	5-11/16	13-5/16

SOLENOID VOLTAGE

Designator	Voltage
B	120V 60 Hz
C	240V 60 Hz
D	480V 60 Hz

HOW TO ORDER: Add the number of outlets (up to 6) to the model number. On solenoid versions, add a "B", "C", or "D" from chart above.

Other Voltages and Frequencies Available. Consult Factory.

ACCESSORIES:

Type S applicator brackets are ordered separately, please see ST Series Valves/S Series Applicator document.

Applicators are ordered separately, please see Applicator document.

V Series Valves & VM Manifolds

APPLICATIONS:

V series valves are used with full flow dispensers where feed rate adjustment is desired at the point of lubrication.

VM series manifolds are used with full flow dispensers and allow Trico applicators to be mounted directly to them. With adjustable adapters and integral needle valves, these manifolds allow easy setting at the point of lubrication.

FEATURES:

- Horizontal design of needle valve minimizes contamination at the valve seat.
- V series valves and VM manifolds have 1 to 6 outlets.
- Clean out plugs provide easy cleaning when required.
- Heavy wall acrylic or heat resistant glass sights allow easy setting of the desired drip rate.
- Silver brazing of all brass construction provides long life and leak proof design.



SPECIFICATIONS

Max. Operating Temp.	Glass 250°F Continuous Acrylic 165°F Continuous
Oil Sight	Heavy Wall Heat Resistant Glass Heavy Wall Acrylic Plastic
Gasket	Buna-N
Packing Gland	Graphite
Material	Brass
Finish	Lacquered Satin Finish
Needle Valve	Brass

SELECTION CHART - V SERIES VALVES

1/4 Tube Connector Furnished.

Model No.		No. of Valve Outlets	Mounting Stud	Dimensions (in.)		
Glass	Acrylic			A	B	C
30171	30271	1	1/4-20	2	5/8	-
30172	30272	2	1/4-20	2-11/16	31/32	-
30173	30273	3	1/4-20	3-3/8	1-5/16	-
30174	30274	4	1/4-20	4-1/16	1-21/32	-
30175	30275	5	1/4-20	4-3/4	2	-
30176	30276	6	1/4-20	5-7/16	5/8	3-7/16

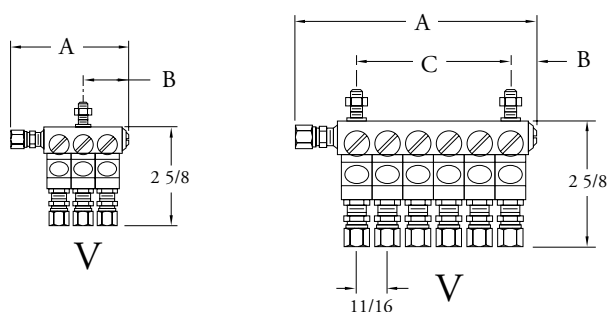

SELECTION CHART - VM MANIFOLDS

1/4 Tube Connector Furnished

Model No.		No. of Valves	Mounting Stud	Dimensions (in.)
Glass	Acrylic			A
35581	35591	1	1/4-20	-
35582	35592	2	1/4-20	-
35583	35593	3	1/4-20	4
35584	35594	4	1/4-20	6
35585	35595	5	1/4-20	8
35586	35596	6	1/4-20	10

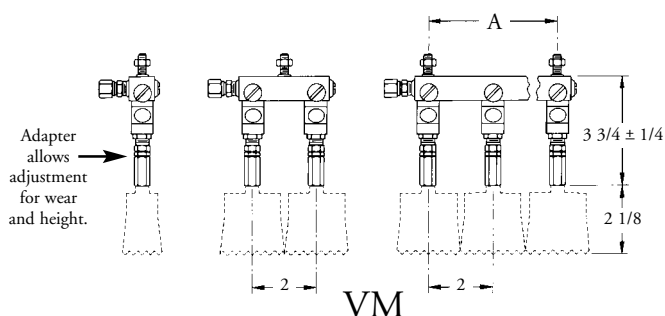

ST Series Valves / S Series Applicator

APPLICATIONS:

ST series valves are used with full flow dispensers where feed rate adjustment is desired at the point of lubrication. When variable operating conditions require frequent adjustment, the large, knurled knob simplifies setting the desired feed rate.



SPECIFICATIONS

Max. Operating Temp.	220°F Continuous
Oil Sight	Heavy Wall Heat Resistant Glass High Impact Strength Polycarbonate Plastic
Gasket	Buna-N
Packing Gland	Self Lubricating Buna-N
Material	Brass
Finish	Lacquered Satin Finish
Needle Valve	Brass

FEATURES:

- Horizontal design of needle valve minimizes contamination at the valve seat.
- Double female or double male threads simplify installation.
- Heavy wall polycarbonate or heat resistant glass sights allow easy setting of the desired drip rate.
- Silver brazing of all brass construction provides long life and leak proof design.
- Clear lacquer finish of brass components resists corrosion.

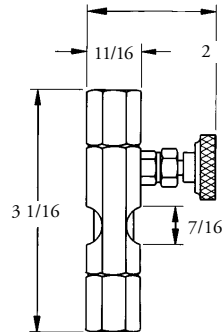

ST Double Female
(Parallel Sight Shown)

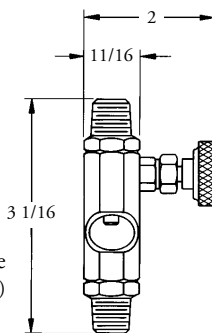

ST Double Male
(Right Angle Sight Shown)

SELECTION CHART

Double Female

Model No.		Connection (NPT)		Sight Position
Glass	Plastic	In	Out	
32401	32405	1/8	1/8	Parallel
32402	32406	1/4	1/4	Parallel
32403	32407	1/8	1/8	Right Angle
32404	32408	1/4	1/4	Right Angle

SELECTION CHART

Double Male

Model No.		Connection (NPT)		Sight Position
Glass	Plastic	In	Out	
32391	32395	1/8	1/8	Parallel
32392	32396	1/4	1/4	Parallel
32393	32397	1/8	1/8	Right Angle
32394	32398	1/4	1/4	Right Angle

S SERIES APPLICATOR BRACKETS

APPLICATIONS:

S series applicator brackets provide an easy way to mount Trico applicators in remote mounting applications. These brackets are used with full flow dispensers.

FEATURES:

- Rigid steel extrusion, nickel plated for durable installation.
- Mounting hole and 1/4 in. tubing connector simplifies installation.
- Adjustable for brush wear.

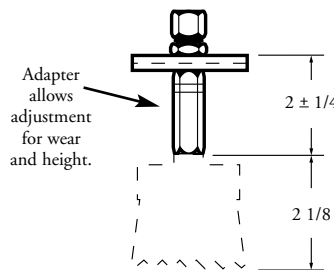

SELECTION CHART

Model No.	Gang	Mounting Hole Diameter (in.)
36024	1	17/64



Applicators

EVEN-FLO® APPLICATORS



APPLICATIONS:

The unique internal reservoir design of these applicators allow uniform dispensing of oil for chain lubrication. They are capable of handling a wide viscosity range of oils. Stainless steel models provide long life and excellent cleaning capability in harsh environments. Nylon and stainless steel models rated to 160°F.

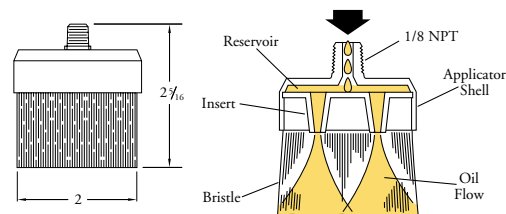

SELECTION CHART

1/8 NPT connections.

Model No.	Bristle Type
36051	Nylon
36054	Stainless Steel

EVER-LAST® APPLICATORS



APPLICATIONS:

Patented Ever-Last applicators use four part construction to provide long life in the most demanding applications. Using ordinary shears, they may be trimmed to fit the exact size of chain and eliminate uneven wear of the applicator or side dripping of the lubricant. Using a neoprene cover and felt plate, the mechanical motion of the chain movement sets up a pumping action in the applicator. Temperature rating of 200°F.

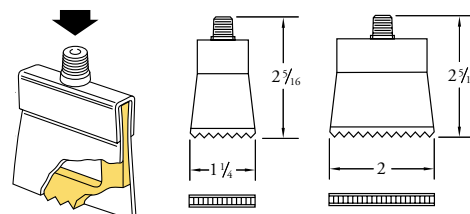

SELECTION CHART

1/8 NPT connections.

Model No.	Width (in.)
36033	1-1/4
36036	2

ROUND BRUSH APPLICATORS



APPLICATIONS:

Trico round brushes are used in applications requiring broad contact surfaces for lubricating and cleaning. They offer even oil distribution on the wearing points of chain. Stainless steel models provide long life and excellent cleaning capability in harsh environments. Nylon and stainless steel models rated to 160°F.

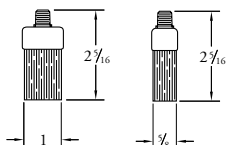

SELECTION CHART

1/8 NPT connections.

Model No.	Size (in.)	Bristle Type
36039	5/8	Nylon
36042	5/8	Stainless Steel
36045	1	Nylon
36048	1	Stainless Steel

ROTARY APPLICATORS



APPLICATIONS:

Trico rotary applicators are used to lubricate and clean chains. Available with a 3 inch nylon or stainless steel rotary brush, they provide chain driven cleaning or lubricating at the speed of the chain. They may be mounted in any orientation to the chain, but when located under the chain they are only used for cleaning. Nylon brushes rated for temperatures to 250°F and stainless steel models rated to 400°F.

REPLACEMENTS: BRUSHES

Model No.	Description
36090	3" Nylon Rotary Brush (1 pair)
36093	3" Stainless Steel Rotary Brush (1 pair)

REMOTE ROTARY BRACKET FOR 1/4" TUBE

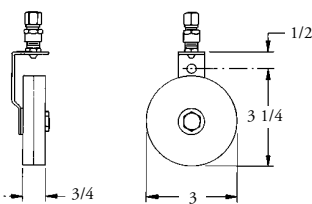

ACCEPTS
1/4 O.D. TUBE
5/16 MOUNTING
HOLE

Model No.	Bristle Type
36072	Nylon
36075	Stainless Steel

REMOTE ROTARY BRACKET/VALVE ASSEMBLY

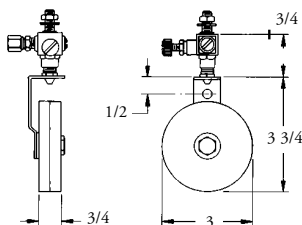

ACCEPTS 1/4 O.D.
TUBE 5/16-18
MOUNTING STUD
5/16 MOUNTING HOLE

Model No.	Bristle Type
36084	Nylon
36087	Stainless Steel

ROTARY BRACKET ASSEMBLY WITH MOUNTING STUD

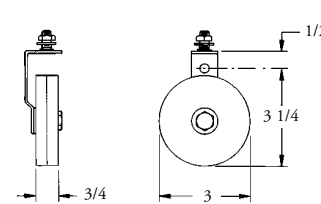

5/16-18
MOUNTING STUD
5/16
MOUNTING HOLE

Model No.	Bristle Type
36078	Nylon
36081	Stainless Steel

Introduction to Grease Lubrication

GREASE BASICS:

Grease is a dispersion of solid or semi solid additives, sometimes called soaps or thickeners. The purpose of grease is to lubricate moving parts while the thickener acts as a sponge, under pressure, to release the base fluid when needed.

Typically, greases are used when oil cannot adequately stay in place due to design considerations. They may also be used when it is desirable to seal out contaminants, prevent lubricant squeeze out, and resist high temperatures.

There are several methods of applying grease to the point of lubrication. The most common forms are manual, single point, and automatic/centralized lubrication. Trico offers single point lubricators.

TYPES OF SINGLE POINT LUBRICATORS (SPL):

Single point lubricators are a storage device designed to slowly dispense grease to the point of lubrication, typically a bearing, over a period of time. These devices are usually mounted in the port that a Zerk fitting occupies. They may be driven mechanically, electrically, pneumatically or by a chemical reaction process. Typically, the user sets the dispense rate to meet the requirements of the bearing based upon its size, type, speed, and orientation.

Trico offers three different types of single point grease lubricators.

- **Mechanical** - Spring loaded that drives a plunger to feed grease.
- **Electro-Chemical** - A battery operated timer activates an electrochemical cell producing expandable gas that generates pressure against a piston.
- **Electro-Mechanical** - A battery operated timer activates a motor attached through a small gearbox to drive a cam that activates a piston pump while ejecting a fixed amount of grease.

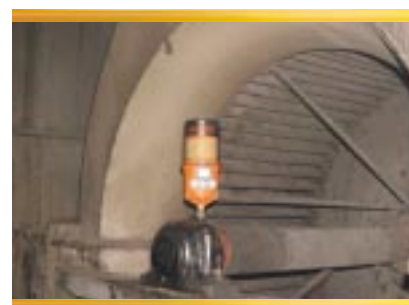

Grease lubricator installed on a blower fan.

WHY USE SINGLE POINT LUBRICATORS

When selected and used properly, single point grease lubricators can solve maintenance and reliability problems. The following points outline where single point lubricators might be advisable to use:

- To prevent contamination
- An alternative to manual lubrication
- Provides a constant flow of lubricant in small volumes to achieve superior lubrication at low unit cost
- Easy to operate
- Frequent re-lubrication applications
- When there is insufficient staff to ensure proper lubrication
- Cost of automatic lubrication systems can't be justified
- Difficult access or safety hazard for manual system



Grease lubricator installed on pillow block of a dynamometer.

Streamliner™ Grease Dispensers



Streamliner™ grease dispensers apply a precise flow of grease to critical machine parts. They are a cost-effective alternative to fully integrated lube systems or manual lubrication. The grease dispensers are ideal for industries where high volumes of moisture, accelerated temperatures and contamination are present.

Streamliner grease dispensers are available in a variety of styles, so they can be matched for optimal performance within any application. Their simplicity in operation insures dependability and ease of service.

Streamliner GL-P

Mechanical – spring loaded

- Anodized aluminum base resists corrosion and works well in high vibration applications
- Clear reservoir for easy viewing of grease levels
- Each unit supplied with three different spring sizes for maximum versatility

- Refillable
- Versatile

Streamliner GL-M

Mechanical – spring loaded

- Double spring design for more uniform dispensing pressure (+/- 6%)
- External level indicator
- Available in three spring sizes for different force requirements
- Excellent in high vibration applications

- Refillable
- Dual spring design

SPECIFICATIONS - GL-P Series

Max. Operating Temp.	212°F
Spring Force	Light (5 psi), medium (10 psi), and heavy (15 psi) included with each model
Grease Capacity	2-1/2 ounces
Thread Sizes	1/8", 1/4", 3/8", and 1/2" NPT

PART NUMBERS - GL-P Series

Model No.	NPT	Spring Force
33301	1/8	Light, medium, and heavy spring included with each model
33302	1/4	
33303	3/8	
33304	1/2	

SPECIFICATIONS - GL-M Series

Max. Operating Temp.	250°F
Spring Force	Light, medium, and heavy sold individually as separate units
Thread Sizes	1/8" and 1/4" NPT
Grease Capacity	2-1/4 ounce

PART NUMBERS - GL-M Series

Model No.	NPT	Spring Force
33321	1/8	Light (5 psi)
33322		Medium (10 psi)
33323		Heavy (15 psi)
33324	1/4	Light (5 psi)
33325		Medium (10 psi)
33326		Heavy (15 psi)

Streamliner™ Grease Dispensers

Streamliner V

Variable feed rate with electro-chemical drive

- Pre-filled with one of five standard grease types
- Microprocessor control
- Large LCD display
- Six variable dispensing rates – 1, 2, 3, 6, 12 months, and purge
- Auto purge cut-out
- Economical 125cc or 250cc reservoir capacity for fewer replacements and less disposal
- Indication of operation with green LED
- Transparent reservoir for easy viewing of grease level
- Unit can be deactivated and adjusted as necessary



PART NUMBERS - V Series

Model No.	Grease Type	Units/Case
33340	Multipurpose	10
33341	Heavy Duty	
33342	High Speed	
33343	Food Grade	
33344	High Temperature	

*125cc also available, please call Trico for further info.

SPECIFICATIONS - V Series

Operating Temp.	-4°F to 140°F
Max. Working Pressure	80 psi
Dispensing Rates	1, 2, 3, 6, 12 months, and purge
Grease Capacity	250cc
Thread Size	3/8" NPT
Anti-Explosive Certi Grade	Ex ia I/II B T6

Streamliner MS unit also available

The MS unit has all the same features and specifications as the M unit and in addition, is capable of operating only when the equipment is running.

PART NUMBERS - MS Series

Model No.	Capacity	Units/Case
33366	250cc	Single Unit

Streamliner M

Variable feed rate with electro-mechanical drive

- Easy to read LCD display
- Microprocessor control
- High operating pressure of 280 psi for contamination removal and multi-point lubrication
- Multi-point lubrication capability – up to four points
- Six variable dispensing rates – half, 1, 2, 3, 6, and 12 months
- Anti-vibration, break-free design
- Unit can be deactivated and adjusted as necessary
- CE and UL approved

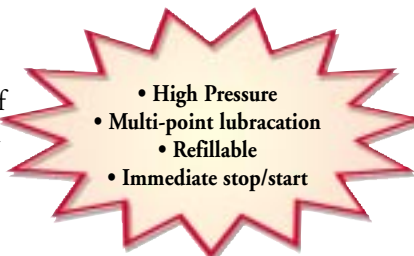

PART NUMBERS - M Series

Model No.	Capacity	NPT	Units/Case
33347*	125cc	3/8	8
33348*	250cc		

*Grease pouch and battery pack sold separately as Service Pack.

SPECIFICATIONS - M Series

Grease Pouch Capacity*	125cc and 250cc (replaceable)
Power Supply*	DC 4.5 V (replaceable)
Max. Operating Pressure	800 psi
Normal Operating Pressure	280 psi
Operating Temperature	-4°F to 140°F
Dispensing Rates	Half, 1, 2, 3, 6, and 12 months
Lube Cycle	Approx. 20 seconds/stroke
Dispensing Volume	.33 +/- .01 gram/stroke @ 68°F
Dispensing Accuracy	+/- 3% @ 68°F

*Grease pouch and power supply are replaceable in one package (Service Pack).

Streamliner™ Grease Dispensers

Grease Selection *For Streamliner V and M versions only

Grease Type	NLGI#	Description
Multi-Purpose	2	Multi-purpose grease for applications with low to moderately high temperatures or loads.
Heavy-Duty	2	High performance grease for heavy-duty applications, good anti-wear and high load carrying capacity.
High Speed	2	High performance grease specially designed for high-speed applications above 3,000 rpm.
Food Grade	1	USDA H1 classification high performance aluminum complex grease for food applications.
High Temp.	2	Fully synthetic high performance grease for extreme temperature applications.

*OEM filling is available. For specific terms and conditions, please contact Trico Mfg. Corp.

SERVICE PACK *For Streamliner M versions only

Model No.	Capacity	Grease Type	Units/Case
33349	125cc	Multipurpose	20
33350		Heavy Duty	
33351		High Speed	
33352		Food Grade	
33353		High Temperature	
33356	250cc	Multipurpose	
33357		Heavy Duty	
33358		High Speed	
33359		Food Grade	
33360		High Temperature	

125 cc Service Pack

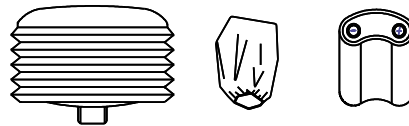

250 cc Service Pack

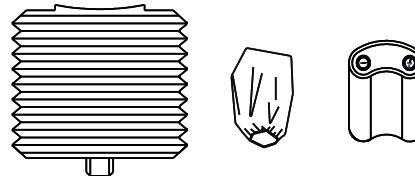

ACCESSORY ITEMS



Model No.	Descriptions
33400	Streamliner™ V Model Installation Kit
33401	Streamliner™ M Model Installation Kit
33402	Streamliner™ M Installation Kit (2 Point)
33403	Streamliner™ M Installation Kit (4 Point)
33404	Streamliner™ M Installation Kit (6 Point)
33405	Streamliner™ M Installation Kit (8 Point)

Trico provides a wide range of adapters, mounting brackets, tubing and divider blocks for remote and multi-point installations.

Introduction to Central Lubrication



Single Line Resistance Systems - Trico central lubrication products are commonly known as Single Line Resistance Systems. They are used throughout industry where reliable oil lubrication is required. The basic principles of these systems are:

- Oil lubrication.
- Pump operation to deliver the oil to the system.
- Individual control of oil lubrication amounts at each lubrication point.
- Meter and control units create resistance to flow to apportion oil delivery.
- Total loss or re-circulating systems.

Positive Displacement Injection Systems – Trico offers a line of products that complement the single line resistance systems. Instead of using meter or control units, a piston dispenses a pre-set amount of oil at each cycle of the pump. These systems do require that different pumps be used than with single line resistance systems. All fittings and tubings are interchangeable between the two systems.

Common applications are shown below. These are found on punch presses, milling machines, printing presses, injection molding machines, textile machinery, and all types of machine tools.

<p>Ball Bearings</p>	<p>Plain Bearings</p>
<p>Flat Slides</p>	<p>Cylindrical Slides</p>
<p>Ball Bearing Slides</p>	<p>Cams</p>
<p>Gears</p>	<p>Chains</p>

Basic Types of Systems

MANUAL PUMPS

These single-shot systems use a manually actuated pump for applications where infrequent lubrication is required.

FEATURES:

- Low cost, simplified installation and operation.
- Manual and spring discharge pumps.
- Reservoir capacities to 450 cc.
- Applications with less than 50 points.
- Used with meter units.
- Total loss systems.

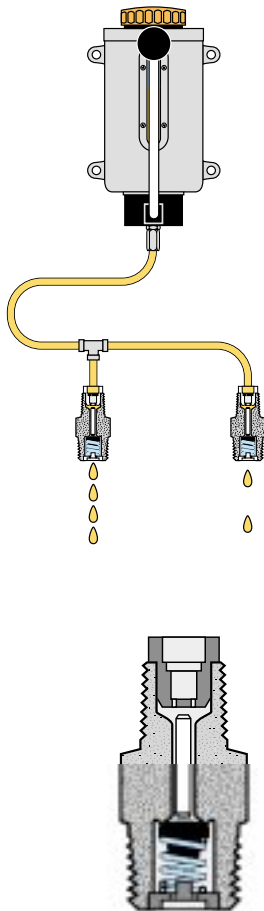

Manual or single-shot pumps use **meter units** to apportion the amount of oil at each lubrication point.

AUTOMATIC CYCLIC PUMPS

For those who need automatic lubrication on an intermittent basis, a cyclic system is required. Cost for these systems are economical and vary based on the type of control used to regulate the lube interval and capacity of the reservoir.

FEATURES:

- Spring discharge and gear pumps.
- Adjustable interval times between lubrication.
- Adjustable oil volume outputs.
- Reservoir capacities up to 20 liters.
- Applications with up to 50 lubrication points.
- Used with meter units.
- Total loss systems.

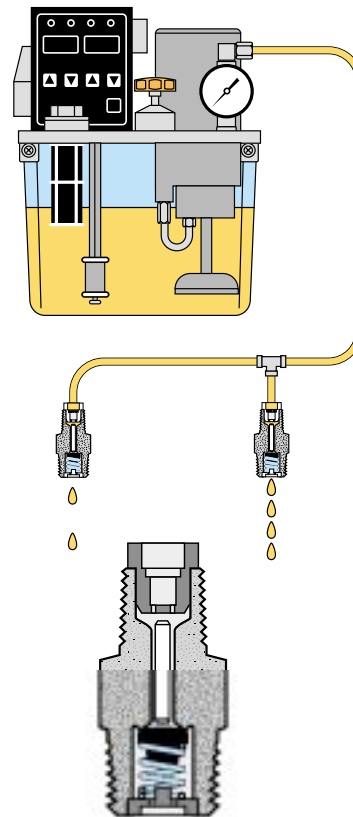

Automatic Cyclic pumps use **meter units** to apportion the amount of oil at each lubrication point.

CONTINUOUS PUMPS

For large lubrication requirements a continuous system should be used. These systems are commonly used on equipment with a high number of lubrication points.

FEATURES:

- Gear pump design.
- Constant oil volume outputs.
- Reservoir capacities up to 20 liters.
- Applications with up to 200 lubrication points.
- Used with control units.
- Total loss systems or re-circulating systems.

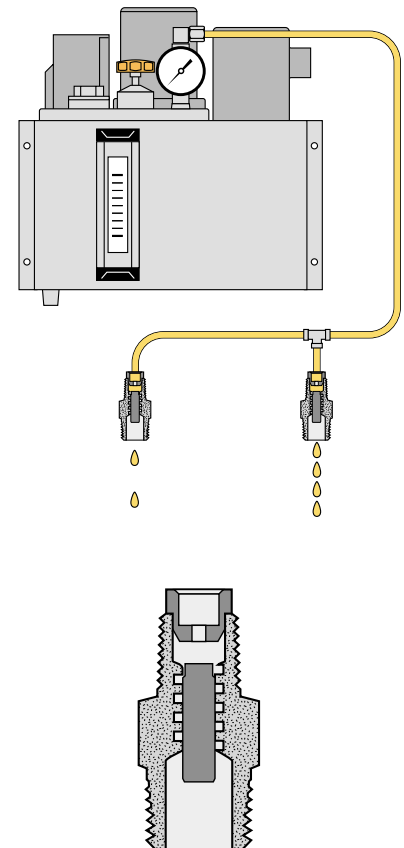

Continuous pumps use **control units** to apportion the amount of oil at each lubrication point.

Positive Displacement Injectors

APPLICATIONS:

Positive Displacement Injectors (PDI's) are an excellent means of providing oil lubrication to machinery. Using a piston principle, the PDI will lubricate individual points with specific amounts of oil. There are 6 output sizes to choose from: 0.06, 0.10, 0.16, 0.20, 0.30, and 0.50 cc's per cycle. A typical system will include a pump, any number of PDI's, and the necessary tubing and fittings.

At the start of the lubrication cycle, the PE-34 or PE-44 Series pump builds pressure. Upon pressure build-up, the PDI's deliver the pre-set amount of oil. At the end of the lubrication cycle, a pressure unloading valve opens to return line pressure to 0 PSI. This allows the PDI's to reset for the next cycle.



HOW TO ORDER:

1. For each lubrication point, select the appropriate Positive Displacement Injector (PDI) based on the oil output per cycle.
2. Select the manifolds required for mounting that simplify installation.
3. Select either a PE-34 Series Automatic Cyclic pump with built-in cycle controls, or a PE-44 Series standard pump that uses external controls for the lubrication cycle. A choice of reservoir capacities is available for both pumps.

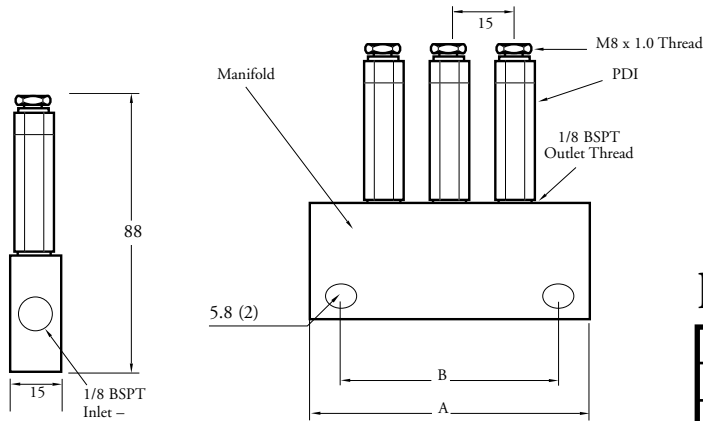

(Note: All dimensions are mm.)

PDI SELECTION CHART

Model No.	Output Volume (cc/cycle)
PDI-06	0.06
PDI-10	0.10
PDI-16	0.16
PDI-20	0.20
PDI-30	0.30
PDI-50	0.50

PDI SPECIFICATIONS

Inlet Thread Size	1/8 BSPT
Outlet Thread Size	M8 x 1.0
Operating Pressure	200 PSI
Pump Required	PE-34 or PE-44
Oil Viscosity	30-250 CST (150-1250 SUS)

MANIFOLDS SELECTION CHART

Model No.	No. of Outlets	Dimensions (mm)	
		A	B
PDM-42	2	47	37
PDM-43	3	62	52
PDM-44	4	77	67
PDM-45	5	92	82
PDM-46	6	107	97

MANIFOLD SPECIFICATIONS

Connection Port	Thread Size	No. of Ports
Inlet	1/8 BSPT	2
Outlet	1/8 BSPT	2 to 6

Pumps for PDI Systems

PUMP SELECTION CHART

Model No.	Pump Type	Reservoir Capacity (liters)	Oil Delivery Time	Interval Time Between Cycles
PE-3403	Auto-Cyclic with Integral Digital Controls	3	1-999 sec.	1-999 minutes
PE-3406		6		
PE-3408		8		
PE-3420		20		
PE-4403	Standard Pump for User Installed Controls	3	User Installed	User Installed
PE-4406		6		
PE-4408		8		
PE-4420		20		

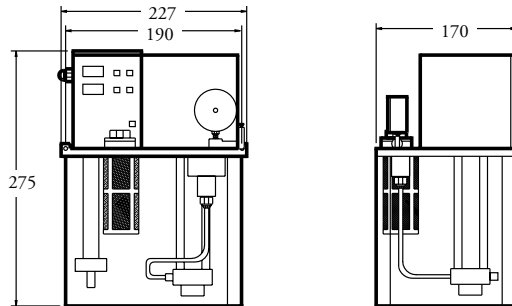

3 Liter Reservoir

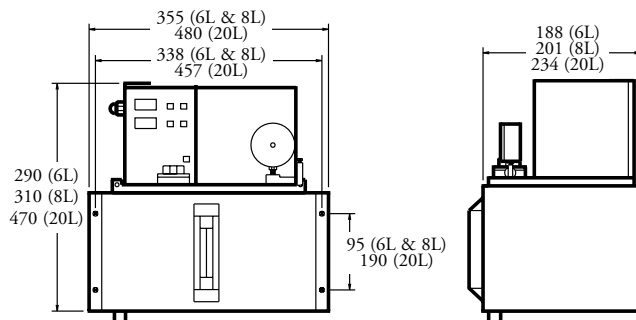

(Note: All dimensions are mm.)
6, 8 and 20 Liter Reservoirs

PUMP SPECIFICATIONS

	PE-34 and PE-44 Series
Motor Voltage	110-1-50/60 Standard 220-1-50/60 Optional
Pump Type	Gear Pump
Maximum Pressure	200 PSI
Maximum Flow	100 cc/min
Output Connection	5/16-24 (f)
Seals	Buna-N
Oil Viscosity	30-250 CST (150-1250 SUS)

PM-10 & 20 Series Manual Cyclic Pumps

APPLICATIONS:

PM series pumps are used in applications where a fixed output of lubricant is desired. With the PM-10 series, the leverage of the pump handle enables the unit to deliver a higher pressure than most models, providing the ability to lubricate points having some back pressure. With the PM-20 series, lubricant output takes place upon release of the handle using spring discharge to assure the correct amount of lubricant is applied. These pumps are commonly used with meter units in single or multiple point applications. Common applications include punch presses and milling machines where infrequent but reliable lubrication is required.

FEATURES:

- Aluminum die cast reservoir provides long life.
- Outputs to 6 or 8 cc/stroke.
- Sight gauge provides liquid level observation.
- Large fill port for easy adding of lubricant.
- Convenient drop-in filter in fill port keeps oil clean.



PM-2000-R

PM-1000-06

SPECIFICATIONS

Reservoir Material	Cast Aluminum
Pump Type	PM-10 Series, Manual Piston Pump PM-20 Series, Spring Discharge Piston Pump
Output Connection	5/16-24 (f)
Seals	Buna-N
Operating Temperature	32-120° F

SELECTION CHART

Model No.	Pump Type	Output cc/stroke	Pressure (PSI)	Capacity (cc)
PM-1000-06	Vertical Mount	6	200	250
PM-1000-08		8	200	450
PM-2000-L	Horizontal Mount	8	70 (average)	550
PM-2000-R		8	70 (average)	550

ACCESSORIES: Meter units, and fittings and accessories are available.

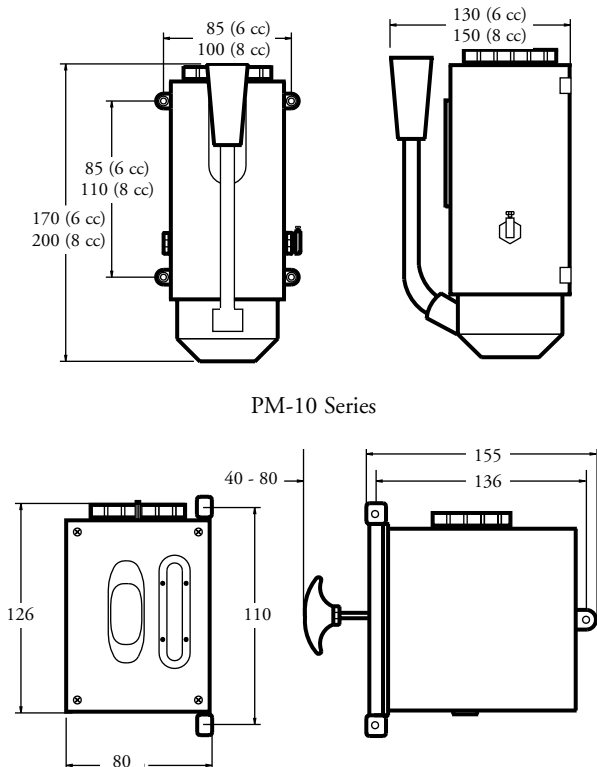

PM-10 Series

PM-20 Series

(Note: All dimensions are mm.)

PE-10 & 12 Series Automatic Cyclic Pumps

APPLICATIONS:

In heavy duty applications requiring a timed delivery of lubricant, the PE 10 and 12 series automatic cyclic pumps are used. These durable pumps provide long life and trouble-free service. With variable lubricant outputs and a choice of cycle times, they offer excellent versatility in many applications. An adjustment screw with a calibrated rod simplifies setting the lubricant delivery output. These pumps are used with meter units in multiple point applications. Common applications include punch presses, milling machines, and other machine tools.

FEATURES:

- Transparent 2 liter reservoir simplifies viewing oil level.
- PE 12 series provided with low level switch to signal when lubricant level is low.
- Adjustable output range of 3 to 6 cc/cycle, or 3 to 120 cc/hour.
- Large fill plug simplifies adding or changing lubricant.
- Convenient drop-in filter in fill port keeps oil clean.

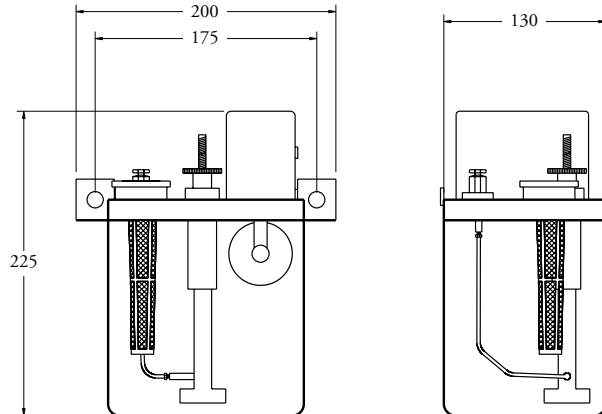

(Note: All dimensions are mm.)

ACCESSORIES: Meter units, and fittings and accessories are available.

Helpful Tip:

For assistance on designing a central lubrication system, visit our website at www.tricomfg.com/central-lubrication.asp



PE-1002-05

SPECIFICATIONS

Reservoir Capacity	2 Liters
Motor Voltage	110-1-50/60 Standard 220-1-50/60 Optional
Pump Type	Spring Discharge Piston Pump
Maximum Pressure	40 PSI
Output Connection	5/16-24 (f)
Seals	Buna-N
Operating Temperature	32-120° F

SELECTION CHART

Model No.	Output (cc/cycle)	Interval Time Between Cycles (min.)	Minimum Output (cc/hour)	Maximum Output (cc/hour)	Low Level Switch
PE-1002-03	Adjustable 3-6	3	60	120	No
PE-1002-05		5	36	72	
PE-1002-10		10	18	36	
PE-1002-15		15	12	24	
PE-1002-30		30	6	12	
PE-1002-60		60	3	6	
PE-1202-03		Yes	3	60	120
PE-1202-05			5	36	72
PE-1202-10			10	18	36
PE-1202-15			15	12	24
PE-1202-30			30	6	12
PE-1202-60			60	3	6

Add "-220" to model number for 220 volt motor.

PE-20, 22, & 24 Series Automatic Cyclic Pumps



FEATURES:

PE-20 Series

- Adjustable interval time between lubrication cycles of up to 60 minutes.
- Heavy duty plastic reservoir simplifies oil level viewing.
- Choice of 6 cc or 15 cc output per cycle.
- Low level switch with alarm.

PE-22 Series

- Adjustable interval time between lubrication cycles of up to 60 minutes.
- Heavy duty plastic reservoir simplifies oil level viewing.
- Choice of 6 cc or 15 cc output per cycle.
- Low level switch with alarm.
- Pressure gauge.

PE-24 Series

- Adjustable interval time between lubrication cycles of up to 180 minutes.
- Heavy duty plastic reservoir simplifies oil level viewing.
- Adjustable output cycle time of 1-180 sec., flow rate of 200 cc/min.
- Low level switch with alarm.
- Pressure gauge.

APPLICATIONS:

The PE-20 series pumps are designed for automatic cyclic systems with fewer than 50 points. These pumps are ideal for punch presses and machine tools where small and consistent amounts of lubricant are required. These pumps are used with meter units in multiple point applications.

SPECIFICATIONS

Reservoir Capacity	2 Liters
Motor Voltage	110-1-50/60 Standard 220-1-50/60 Optional
Pump Type	Gear Pump
Maximum Pressure	PE-20, 22 Series: 100 PSI PE-24 Series: 70 PSI
Output Connection	5/16-24 (f)
Seals	Buna-N
Operating Temperature	32-120° F

SELECTION CHART

Model No.	Output	Interval Time Between Cycles	Minimum Output (cc/hour)	Low Level Switch	Low Level Alarm and Pressure Gauge
PE-2002-06	6 cc/cycle	0 min. to 60 min.	6	Yes	No
PE-2002-15	15 cc/cycle		15		
PE-2202-06	6 cc/cycle		6		
PE-2202-15	15 cc/cycle		15		
PE-2402	3.33 cc/sec. Variable delivery time of 1-180 sec.	1 min. to 180 min.	1.1		Yes

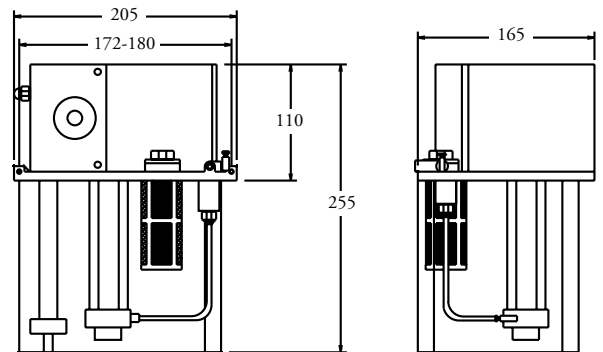

(Note: All dimensions are mm.)

Add "-220" to model number for 220 volt motor.

* Note: Interval time must be 5 times lubricating time and at least 3 minutes.

ACCESSORIES: Meter units, and fittings and accessories are available.

PE-30 & PE-32 Series Automatic Cyclic Pumps

FEATURES:

PE-30 & PE-32 Series

- Low level switch with alarm
- Pressure gauge
- Heavy duty plastic reservoir (3 liter) simplifies oil level viewing. Metal reservoirs available in 6, 8, and 20 liters for larger systems.

PE-30 Series

- Adjustable output cycle time of 1-180 seconds, flow rate of 200 cc/min
- Adjustable interval time between lubrication cycles of 3-999 minutes.

PE-32 Series

- Adjustable output cycle time of 1-999 seconds, flow rate of 250 cc/min.
- Adjustable interval time between lubrication cycles of 3-999 minutes.
- Pressure adjustment valve.
- Pressure switch, with reset button, shuts down pump if system pressure drops below set level, protecting against line or component failure.



PE-3003



PE-3203

APPLICATIONS:

The PE-30 & PE-32 series are the most versatile automatic cyclic pumps available. Both the lubricant dispensing time, and the time interval between cycles is digitally controlled. With reservoir sizes up to 20 liters, these pumps can handle systems with up to 100 lubrication points. Applications include large printing presses and injection molding machines. These pumps are used with meter units in multiple point applications.

SPECIFICATIONS

Reservoir Capacity	3 Liter Plastic 6, 8, and 20 Liter Steel	
Motor Voltage	110-1-50/60 Standard 220-1-50/60 Optional	
Pump Type	Gear Pump	
Maximum Pressure	100 PSI - PE-30	140 PSI - PE-32
Output Connection	5/16-24 (f)	
Seals	Buna-N	
Operating Temperature	32-120° F	

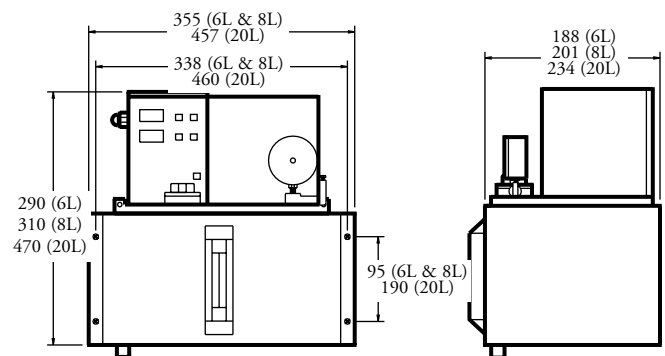

6, 8 and 20 Liter Reservoirs

SELECTION CHART

Model No.	Reservoir Capacity (liters)	Reservoir Material	Output	Interval Time* Between Cycles	Minimum Output (cc/hour)
PE-3003	3	Plastic	3.33 cc/sec. Variable delivery time of 1-180 sec.	3-999 minutes	.2
PE-3006	6				
PE-3008	8				
PE-3020	20				
PE-3203	3	Metal	4.17 cc/sec. Variable delivery time of 1-999 sec.	3-999 minutes	.2
PE-3206	6				
PE-3208	8				
PE-3220	20				

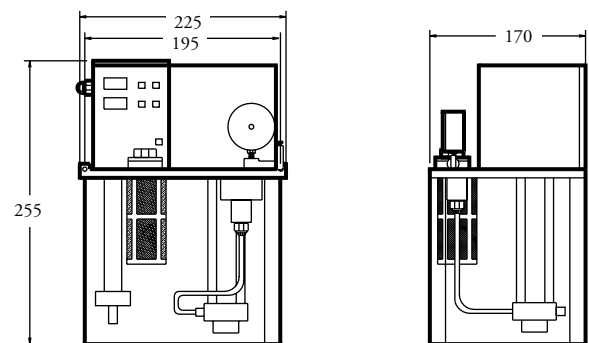

3 Liter Reservoir

(Note: All dimensions are mm.)

Add "-220" to model number for 220 volt motor.

Note: Interval time must be 5 times lubricating time and at least 3 minutes.

ACCESSORIES: Meter units, and fittings and accessories are available.

PE-40 & PE-50 Series Continuous System Pumps



PE-4003



PE-5003

FEATURES:

PE-40 and PE-50 Series

- Standard float switch provides signal when lubricant level is low.
- Easy view plastic reservoir on 3 liter models, steel reservoir with sight gauge on 6, 8 and 20 liter reservoirs.
- Return to tank port available on 6, 8 and 20 liter models for returning unused oil to reservoir.
- Provided with pressure gauge as standard.
- Safety relief valve assures reliable performance.

PE-40 Series

- Pressure switch, with reset button, shuts down pump if system pressure drops below set level, protecting against line or component failure.

APPLICATIONS:

Trico's continuous system pumps are designed for applications where lubrication of critical components is needed on a continual basis, rather than on a timed basis. Using continuous system control units, these pumps provide lubricant at flow rates of 250 cc/min. Common applications include injection molding, printing presses, punch presses, and milling machines.

SPECIFICATIONS

Reservoir Capacity	3 Liter Plastic 6, 8 and 20 Liter Steel
Motor Voltage	110-1-50/60 Standard 220-1-50/60 Optional
Pump Type	Gear Pump
Maximum Pressure	140 PSI
Output Connection	5/16-24 (f)
Seals	Buna-N
Operating Temperature	32 - 120° F

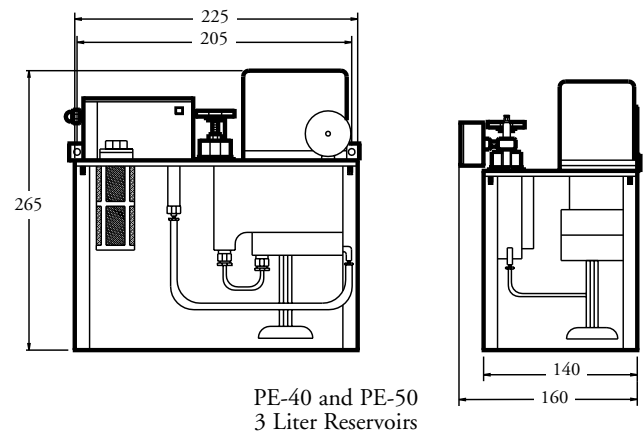
 PE-40 and PE-50
3 Liter Reservoirs

SELECTION CHART

Model No. (standard)	Model No.* (with return to tank port)	Pressure Switch	Reservoir Capacity (liters)	Reservoir Material	Output Volume (cc/min)
PE-4003	-	Yes	3	Plastic	250
PE-4006	PE-4206		6	Metal	
PE-4008	PE-4208		8		
PE-4020	PE-4220		20		
PE-5003	-	No	3	Plastic	
PE-5006	PE-5206		6	Metal	
PE-5008	PE-5208		8		
PE-5020	PE-5220		20		

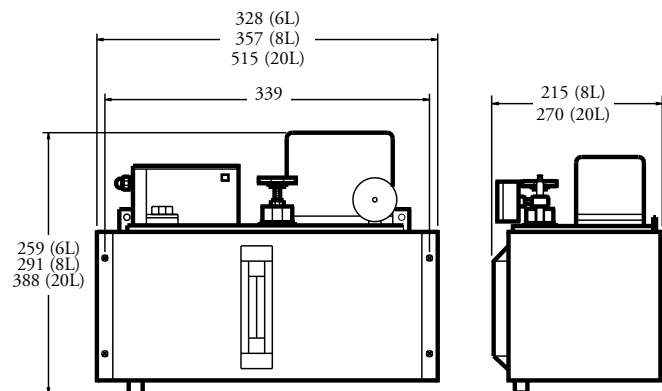

 PE-40 and PE-50
6, 8 and 20 Liter Reservoirs

(Note: All dimensions are mm.)

Add "-220" to model number for 220 volt motor.

*Refer to Accessories document for accessories on return to tank port pumps.

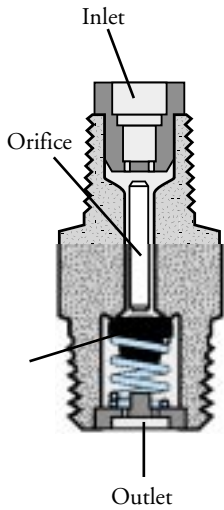
Meter & Control Units



APPLICATIONS:

Meter units are used with all cyclic system electric and manual pumps to provide precise control of the lubricant to each lubrication point. A spring loaded check valve keeps air from entering the system when lubricant is not being supplied to the meter unit.

METER UNITS

Flow Rate	5/16-24 x 5/16-24	5/16-24 x 1/8 NPT	1/8 NPT x 1/8 NPT	M8 x 1.0 x M8 x 1.0	M8 x 1.0 x 1/8 BSPT	1/8 BSPT x 1/8 BSPT
3/0	DSM-3/0	DCM-3/0	DTM-3/0	-	-	-
00	DSM-00	DCM-00	DTM-00	DSM-00M	DCM-00M	DTM-00M
0	DSM-0	DCM-0	DTM-0	DSM-0M	DCM-0M	DTM-0M
1	DSM-1	DCM-1	DTM-1	DSM-1M	DCM-1M	DTM-1M
2	DSM-2	DCM-2	DTM-2	DSM-2M	DCM-2M	DTM-2M
3	DSM-3	DCM-3	DTM-3	DSM-3M	DCM-3M	DTM-3M
4	DSM-4	DCM-4	DTM-4	DSM-4M	DCM-4M	DTM-4M
5	DSM-5	DCM-5	DTM-5	DSM-5M	DCM-5M	DTM-5M

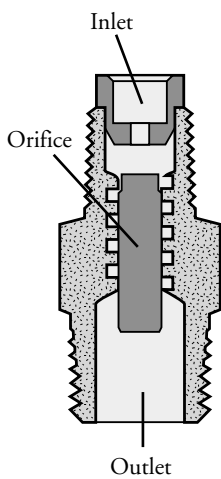

APPLICATIONS:

Control units are used with all continuous system electric pumps to provide precise control of the lubricant to each lubrication point. Because pump flow is continuous, an internal check valve is not required.

CONTROL UNITS

Flow Rate	5/16-24 x 5/16-24	5/16-24 x 1/8 NPT	1/8 NPT x 1/8 NPT	M8 x 1.0 x M8 x 1.0	M8 x 1.0 x 1/8 BSPT	1/8 BSPT x 1/8 BSPT
5/0	DSC-5/0	DCC-5/0	DTC-5/0	-	-	-
4/0	DSC-4/0	DCC-4/0	DTC-4/0	-	-	-
3/0	DSC-3/0	DCC-3/0	DTC-3/0	-	-	-
00	DSC-00	DCC-00	DTC-00	-	-	-
0	DSC-0	DCC-0	DTC-0	-	-	-
1	DSC-1	DCC-1	DTC-1	DSC-1M	DCC-1M	DTC-1M
2	DSC-2	DCC-2	DTC-2	DSC-2M	DCC-2M	DTC-2M
3	DSC-3	DCC-3	DTC-3	DSC-3M	DCC-3M	DTC-3M
4	DSC-4	DCC-4	DTC-4	DSC-4M	DCC-4M	DTC-4M
5	DSC-5	DCC-5	DTC-5	DSC-5M	DCC-5M	DTC-5M

FLOW RATE CHART FOR METER AND CONTROL UNITS

Flow Rate	Relative Flow Delivery	Typical System Type
5/0	1	Continuous loss
4/0	2	Continuous loss
3/0	4	Continuous loss/Cyclic
00	8	Continuous loss/Cyclic
0	16	Continuous loss/Cyclic
1	32	Cyclic /Continuous re-circulating
2	64	Cyclic /Continuous re-circulating
3	128	Cyclic /Continuous re-circulating
4	256	Continuous re-circulating
5	512	Continuous re-circulating

METER AND CONTROL UNITS:

Trico offers 8 different flow rates for meter units (3/0 - 5) and 10 for control units (5/0 - 5). These units are precisely manufactured to accurately apportion oil at each point. To the left is a chart that displays recommended flow rates for different types of systems. The relative flow delivery indicates the difference in the flow rates of the meter and control rates. The smallest flow rate is "5/0" and the highest flow rate is "5". Each meter and control unit will allow approximately twice as much flow as the next smaller size, within a lubrication system.

Fittings

FITTINGS

Illustration	New Model No.	T1	T2
 Male Thread Connector	FC-1002	5/16-24	5/16-24
	FC-1008	5/16-24	1/8 NPT
	FC-1000	1/8 NPT	1/8 NPT
	FC-1003	1/8 NPT	3/8-24
	FC-1004	1/8 NPT	7/16-24
	FC-1005	1/4 NPT	1/8 NPT
	FC-1006	1/4 NPT	7/16-24
	FC-1007	1/4-28 Zerk	1/4-28 Zerk
	FC-1002M	M8 x 1.0	M8 x 1.0
	FC-1000M	1/8 BSPT	1/8 BSPT
	FC-1014	1/8 BSPT	1/8 NPT
	FC-1015	M8 x 1.0	1/8 NPT
	FC-1010M	1/4 BSPT	1/4 BSPT
FC-1017	1/8 BSPT	5/16-24	

Illustration	Model No.	T1	T2
 90° Elbow	FE-1005	5/16-24	5/16-24
	FE-1000	5/16-24	1/8 NPT
	FE-1012	1/8 NPT	1/8 NPT
	FE-1000M	M8 x 1.0	M8 x 1.0
	FE-1001M	M10 x 1.0	M10 x 1.0

Illustration	Model No.	T1	T2
 90° Street Elbow	FE-1007M	M8 x 1.0	1/8 BSPT
	FE-1011M	M8 x 1.0	M8 x 1.0
	FE-1010M	1/8 BSPT	1/8 BSPT

Illustration	Model No.	T1	T2
 90° Street Elbow	FE-1002	5/16-24	1/8 NPT
	FE-1006	1/8 NPT	1/8 NPT
	FE-1009	1/8 NPT	1/4-28 Zerk
	FE-1004M	M8 x 1.0	1/8 BSPT
	FE-1003M	M10 x 1.0	1/8 BSPT
	FE-1014M	1/8 BSPT	1/8 BSPT
	FE-1005M	M8 x 1.0	1/4 BSPT
	FE-1006M	M10 x 1.0	1/4 BSPT

Illustration	New Model No.	T1	T2
 Female Thread Connector	FC-1009	5/16-24	5/16-24
	FC-1012	5/16-24	1/8 NPT
	FC-1018	1/8 NPT	1/8 NPT
	FC-1009M	M8 x 1.0	M8 x 1.0
	FC-1013M	M10 x 1.0	M10 x 1.0
	FC-1012M	M8 x 1.0	1/8 BSPT
	FC-1011M	M10 x 1.0	1/8 BSPT
	FC-1014M	M14 x 1.5	M14 x 1.5

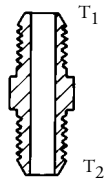
Illustration	Model No.	T1	T2
 90° Elbow	FE-1015	1/8 NPT	3/8-24
	FE-1016	1/8 NPT	7/16-24
	FE-1017	1/4 NPT	7/16-24

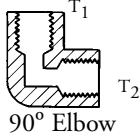
Illustration	Model No.	T1	T2
 45° Street Elbow	FE-1007	1/8 NPT	1/8 NPT
	FE-1013M	1/8 BSPT	1/8 BSPT

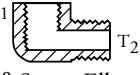
SWIVEL FITTINGS

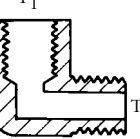
Illustration	Model No.	T1	T2
 Swivel Adapter (Male thread)	FM-2003	1/8 NPSM	1/8 NPT
	FM-2004	1/4 NPSM	1/8 NPT
	FM-2005	1/4 NPSM	1/4 NPT

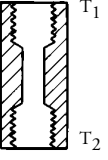
Illustration	Model No.	T1	T2
 Swivel Adapter (Female thread)	FM-2006	1/8 NPSM	1/8 NPT
	FM-2007	1/4 NPSM	1/4 NPT
	FM-2008	3/8 NPSM	3/8 NPT

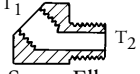
Illustration	Model No.	T1	T2
	FM-2001M	M8 x 1.0	1/8 BSPT
	FM-2002M	1/8 BSPT	1/8 BSPT
	FM-2000	1/8 NPT	1/8 NPT
	FM-2000M	1/8 BSPT	1/8 BSPT

Fittings

FITTINGS

Illustration	New Model No.	T1	T2
<p>Adapter</p>	FA-1007	5/16-24	1/8 NPT
	FA-1008	1/8 NPT	1/8 NPT
	FA-1000	1/4 NPT	1/8 NPT
	FA-1001	5/16-24	5/16-24
	FA-1009	5/16-24	1/4-28 Zerk
	FA-1003	3/8-24	1/8 NPT
	FA-1005	1/8 NPT	5/16-24
	FA-1004	1/8 NPT	1/4-28 Zerk
	FA-1023	5/16-24	1/8 BSPT
	FA-1024	1/8 NPT	M6 x 1.0
	FA-1025	1/8 NPT	M8 x 1.25
	FA-1026	1/8 NPT	M10 x 1.5
	FA-1007M	M8 x 1.0	1/8 BSPT
	FA-1006M	M10 x 1.0	1/8 BSPT
	FA-1013M	M8 x 1.0	1/4 BSPT
	FA-1015M	1/8 BSPT	M10 x 1.0
	FA-1014M	1/8 BSPT	M8 x 1.0
	FA-1016M	1/8 BSPT	1/8 BSPT
	FA-1011M	M10 x 1.0	M8 x 1.0
	FA-1010M	M10 x 1.0	PT 1/4
	FA-1017M	M8 x 1.0	M6 x 1.0
	FA-1023M	M8 x 1.0	M10 x 1.0
FA-1012M	M10 x 1.0	M10 x 1.0	
FA-1017	1/8 BSPT	1/8 NPT	
FA-1018	M8 x 1.0	1/8 NPT	
FA-1020	5/16-24	M8 x 1.0	
FA-1021	M8 x 1.0	5/16-24	
FA-1022	1/8 NPT	1/8 BSPT	

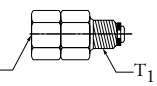
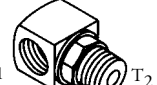
Illustration	Model No.	T1	T2
<p>Straight Bulkhead Connector</p>	FB-1002	5/16-24	5/16-24
	FB-1000	5/16-24	1/8 NPT
	FB-1002M	M8 x 1.0	M8 x 1.0
	FB-1003M	M10 x 1.0	M10 x 1.0
	FB-1000M	M8 x 1.0	1/8 BSPT
	FB-1001M	M10 x 1.0	1/8 BSPT

Illustration	Model No.	T1	T2
<p>Reducer Bushing</p>	FM-1003	3/8 NPT	1/8 NPT
	FM-1004	3/8 NPT	1/4 NPT
	FM-1005	1/2 NPT	1/8 NPT
	FM-1006	1/2 NPT	1/4 NPT
	FM-1007	1/2 NPT	3/8 NPT
	FM-1008	3/4 NPT	1/4 NPT

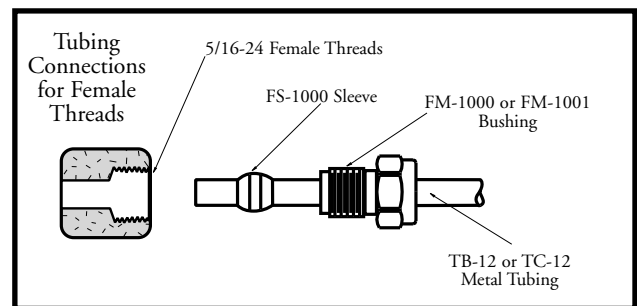
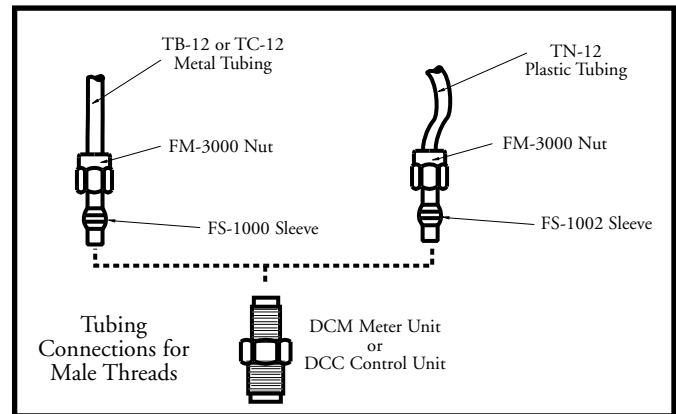

COMPRESSION FITTINGS

Illustration	Description	Model No.	Size	Model No.	Size
	3/8 Hex Bushing	FM-1001	5/16-24	FM-1001M	M8 x 1.0
	5/16 Hex Bushing	FM-1000		FM-1002M	M10 x 1.0
	Nut	FM-3000		FM-3000M	M8 x 1.0
	Metal Sleeve	FS-1000	5/32 (4mm)	FS-1004M	6 mm
	Nylon Half-Sleeve	FS-1002		-	-

TUBING - 12 FOOT LENGTHS

Illustration	Material	Model No.	Tube Size	Model No.	Tube Size
	Brass	TB-12	5/32 (4mm)	-	6mm
	Copper	TC-12		TC6-12M	
	Nylon	TN-12		TN6-12M	

Fittings & Hoses

JUNCTIONS

Illustration	No. of Ports	Inch Threads		Metric Threads	
		Model No.	Thread Size	Metric Model No.	Thread Size
	2	J-02	5/16-24	J-02M	M8 x 1.0
	3	J-03		J-03M	
	4	J-04		J-04M	
	4	JS-04		JS-04M	
	5	JS-05		JS-05M	
	6	JS-06		JS-06M	
	7	JS-07		JS-07M	
	8	JS-08		JS-08M	
	9	JS-09		JS-09M	
	10	JS-10		JS-10M	
	12	JS-12		JS-12M	
	4	JD-04		JD-04M	
	6	JD-06	JD-06M		
	3	JH-03	1/8 NPT (T ₁)	JH-03M	1/8 BSPT (T ₁)
	4	JH-0402	5/16-24 (T ₂)	JH-0402M	M8 x 1.0 (T ₂)

HOSES

Model No.	Diameter	Dimensions (in.)	
		A	B
H-404	5/32 (4 mm)	4	6
H-405		5	7
H-406		6	8
H-407		7	9
H-408		8	10
H-409		9	11
H-410		10	12
H-412		12	14
H-414		14	16
H-416		16	18
H-418		18	20
H-420		20	22
H-422		22	24
H-424		24	26
H-427		27	29
H-430		30	32
H-433		33	35
H-436		36	38
H-440		40	42
H-444		44	46
H-448	48	50	
H-452	52	54	
H-456	56	58	
H-460	60	62	
H-612	6 mm Diameter Hose	12	14
H-624		24	26
H-636		36	38
H-648		48	50

Illustration	Model No.	Thread
	FM-5000	1/8 NPT
	FM-5001	1/4 NPT

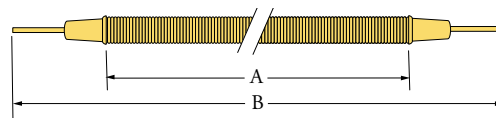

Accessories

PLUGS

Illustration	Inch Threads		Metric Threads	
	Model No.	Size	Model No.	Size
	FP-1003	5/16-24	FP-1003M	M8 x 1.0
			FP-1006M	M10 x 1.0
	FP-1002	5/16-24	FP-1004M	M8 x 1.0
	FP-1001	1/8 NPT	FP-1001M	1/8 BSPT
			FP-1009M	

REPLACEMENT STEEL RESERVOIRS

	6 Liter	8 Liter	20 liter
	MR-1006	MR-1008	MR-1020
	MR-2006 with return to tank port	MR-2008 with return to tank port	MR-2020 with return to tank port

PRESSURE GAUGES

Illustration	Model No.	Connection Thread	Pressure Range	Model No.	Connection Thread	Pressure Range
	MG-1000	1/8 BSPT Rear Mount	0-15 Bar	MG-1002	1/8 BSPT Bottom Mount	0-15 Bar
	MG-1001		0-35 Bar	MG-1003		0-35 Bar

TUBING CLIPS

Illustration	New Model No.	Tube Size
	FT-1001M	5/32 (4mm)
	FT-1004M	
	FT-1006M	
	FT-1003M	6 mm
	FT-1005M	

CHECK VALVES - 5 PSI

Illustration	Flow Direction Towards	Inch Threads			Metric Threads		
		Model No.	Thread Size (T1)	Thread Size (T2)	Metric Model No.	Thread Size (T1)	Thread Size (T2)
	T2	FV-1001	1/8 NPT	5/16-24	FV-1006M	1/8 BSPT	M8 x 1.0
					FV-1007M	1/8 BSPT	M10 x 1.0
	T1	FV-1000	1/8 NPT	5/16-24	FV-1004M	1/8 BSPT	M8 x 1.0
					FV-1003M	1/8 BSPT	M10 x 1.0
	T1	FV-1002	1/8 NPT	5/16-24	FV-1002M	1/8 BSPT	M8 x 1.0
					FV-1005M	1/8 BSPT	M10 x 1.0
	T2	FV-1008	1/8 NPT	5/16-24	FV-1008M	1/8 BSPT	M8 x 1.0
					FV-1009M	1/8 BSPT	M10 x 1.0

ITEMS FOR PUMPS WITH RETURN TO TANK PORTS

	Model No.	MM-6000
	Horsepower	1/4
	Type	Fully closed
	Output	250W
	Pole	4P
	Time Interval	Continuous
	Revolution	1400/1700 RPM
	Voltage	110V
	Frequency	50/60 Hz



Model No.	Theoretic Discharge Capacity (cc/rev)	l/min Discharge Capacity		Max. Pressure (Kgf/cm ²)	Max. RPM	Thread Size
		1500 RPM	1800 RPM			
MP-6000	2.5	3.7 l/min.	4.5 l/min.	5	1800	1/4 NPT

Illustration	Model No.	Thread Size
 Filter	MF-6000	1/4 NPT

Technical Information

OIL SELECTION FOR CENTRAL LUBRICATION:

Many manufacturers of equipment that use central lubrication systems will recommend the specific lubricating oil to be used. If a particular oil is not recommended, then several factors must be considered. Load and friction elements of surfaces to be lubricated are a primary consideration. The ambient temperature during machine operation, and also the speed of the equipment are significant factors. The viscosity of the oil is a measure of how the oil flows at a given temperature. Both the temperature and the operating pressure will determine the resistance to flow of the oil. As the pressure or temperature increases, the oil delivery rate is increased.

Always use clean oil in central lubrication systems. Contamination in the oil will significantly shorten the life of the surfaces being lubricated. Synthetic lubricants tend to be more stable than mineral based ones. However, some synthetic lubricants can attack standard seal material, and seal compatibility must be checked before using any oil type.

To insure the correct choice of lubricating oil, consult the machinery manufacturer or OEM.

VISCOSITY OF OIL LUBRICANTS:

Trico pumps are designed to dispense mineral based lubricants with a viscosity range of 30-250 centistokes or 150 - 1200 SUS. New clean oil is always recommended and users should check with machine manufacturers for the recommended lubricant for their equipment.

TEMPERATURE VISCOSITY RELATIONSHIP

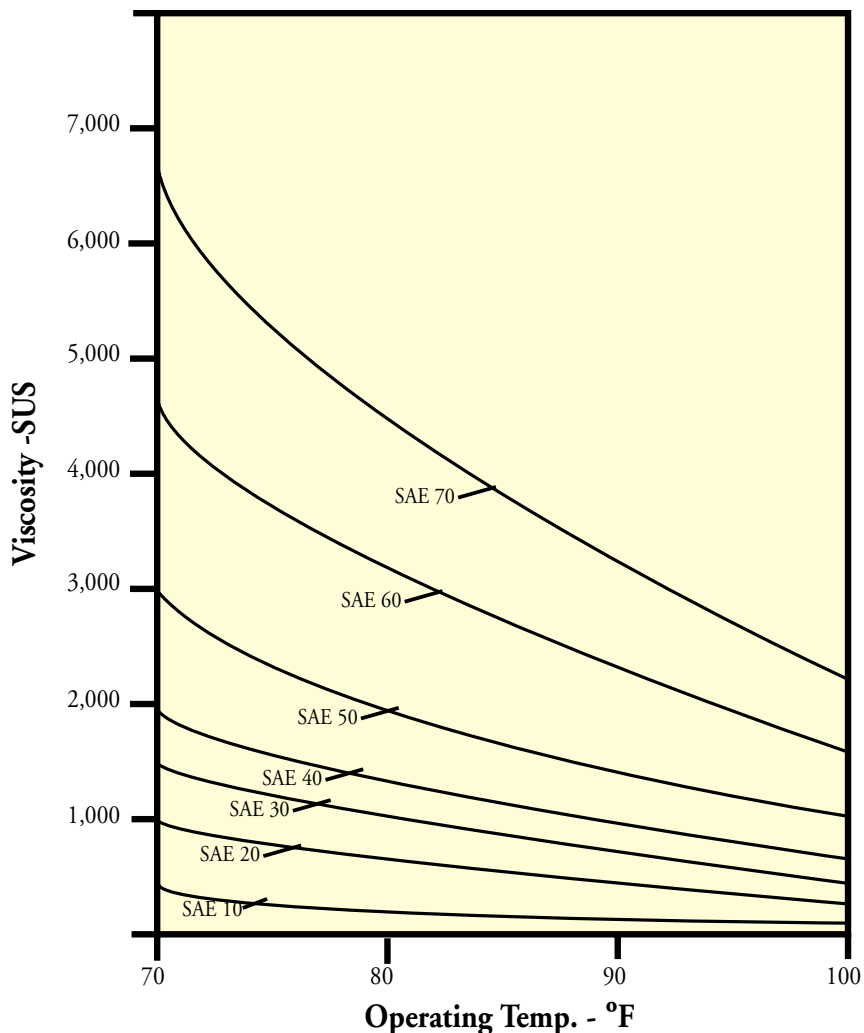

METRIC CONVERSION CHART

1 oz.	30 ml./30cc.
1 pt.	.473 liters
1 qt.	.946 liters
1/2 gal.	1.89 liters
1 gal.	3.785 liters

Using the System Design Worksheet

INSTRUCTIONS - Follow the instructions as listed below using the worksheet.
The worksheet is designed for cyclic systems. For assistance with continuous systems, contact Trico.









STEP 1 - List the lubrication points in the system.
In column A, list each lubricant point by description.

STEP 2 - Determine the lubrication required at each point.
In column B, write the lubrication delivery required at each point in cc/hr. Enter the total delivery required in the total box. Refer to the specification from the machinery manufacturer whenever possible. The Lubricating Calculations table below can be used as a guide in determining lubrication requirements.

STEP 3 - Determine the flow ratios for each lubrication point.
Find the lubrication point requiring the least amount of oil. Divide each of the "Lube Delivery Req'd" values by that amount. Enter these values in column C. This will determine the ratio of lubrication required between all of the lubrication points.

LUBRICATING CALCULATIONS

If the amount of lubrication needed is not specified by the equipment manufacturer, this table can be used as a guide.

Illustration	Application	Oil Required in cc/hour
	Ball Bearings	.10 x bearing diameter (in.) x number of rows or bearings
		.04 x bearing diameter (cm.) x number of rows or bearings
	Plain Bearings	.15 x bearing shaft diameter (in.) x bearing length (in.)
		.023 x bearing shaft diameter (cm.) x bearing length (cm.)
	Flat Slides	.04 x [slide length (in.) + travel (in.)] x slide width (in.)
		.006 x [slide length (cm.) + travel (cm.)] x slide width (cm.)
	Cylindrical Slides	.15 x [slide length (in.) + travel (in.)] x slide diameter (in.)
		.023 x [slide length (cm.) + travel (cm.)] x slide diameter (cm.)
	Ball Bearing Slides	.03 x slide length (in.) x number of slides or rows
		.012 x slide length (cm.) x number of slides or rows
	Cams	.08 x surface area (sq. in.)
		.013 x surface area (sq. cm.)
	Gears	.30 x gear pitch diameter (in.) x face width (in.)
		.046 x gear pitch diameter (cm.) x face width (cm.)
	Chains	.05 x length of chain (in.) x width (in.)
		.008 x length of chain (cm.) x width (cm.)

Using the System Design Worksheet

SIZING CHARTS

© Ratio From: To:	Ⓓ Multip.	Ⓔ Flow Rate	Ⓕ "Q" Value
1.00 → 1.50	1	0	5
1.51 → 3.00	2	1	10
3.01 → 6.00	4	2	20
6.01 → 12.00	8	3	40
12.01 → 24.00	16	4	80
24.01 → 48.00	32	5	160

Chart 1

© Ratio From: To:	Ⓓ Multip.	Ⓔ Flow Rate	Ⓕ "Q" Value
1.00 → 1.50	1	00	2.5
1.51 → 3.00	2	0	5
3.01 → 6.00	4	1	10
6.01 → 12.00	8	2	20
12.01 → 24.00	16	3	40
24.01 → 48.00	32	4	80
48.01 → 96.00	64	5	160

Chart 2

© Ratio From: To:	Ⓓ Multip.	Ⓔ Flow Rate	Ⓕ "Q" Value
1.00 → 1.50	1	3/0	1.25
1.51 → 3.00	2	00	2.50
3.01 → 6.00	4	0	5
6.01 → 12.00	8	1	10
12.01 → 24.00	16	2	20
24.01 → 48.00	32	3	40
48.01 → 96.00	64	4	80
96.01 → 192.00	128	5	160

Chart 3

STEP 4 - Determine which of the three sizing charts to use.

Find the highest ratio listed in Column C. If the highest value is 48 or less, then use sizing chart 1 in step 5. If it is between 49 and 96, then use chart 2 in step 5. If it is between 97 and 192, then use chart 3 in step 5.

STEP 5 - Multiplier, flow rate, and Q value amounts.

Referring to Sizing Chart 1, 2, or 3, fill in the appropriate multiplier, flow rate, and Q value for each lubrication point. Enter the totals for the multipliers and Q values in the total boxes.

STEP 6 - Calculate actual delivery for each lubrication point.

To confirm the actual delivery that each lubrication point will receive, the following calculation is done. For each lubrication point, divide the total oil required in the system by the total of all the multipliers. Multiply that number by the multiplier for that lubrication point. Record the amount in column G.

STEP 7 - Check for flowability.

Divide the viscosity of the oil (SUS at operating temperature), by the total of all the Q values for the system. If the result of that calculation is 61 or less then the system has flowability. If the result is higher than 61, larger meter units are required. Increase each meter unit flow rate value by one size. Add the new Q values that correspond, and repeat the calculation. Continue to do this until the flowability calculation is 61 or less.

STEP 8 - Select the appropriate pump.

Using the pump selection chart, select a pump best suited for the application.

STEP 9 - Choose the appropriate meter units.

Column E has the designated flow rate for each of the meter units. Select the meter unit with thread configuration best suited for each application point.

System Design Worksheet

Please visit our website for assistance on designing a central lubrication system at www.tricomfg.com/central-lubrication.asp

Machine: _____

Lubricant: _____ Viscosity: _____ SUS at _____ °F Oper. Temp.

Prepared By: _____ Date: _____

Lube Point No.	Ⓐ Lubricant Point Description	Ⓑ Lube Delivery Req'd cc/hr	Ⓒ Ratio Between Lube Points	Ⓓ Multiplier	Ⓔ Flow Rate	Ⓕ Q Value	Ⓖ Actual Delivery cc/hr
1							
2							
3							
4							
5							
6							
7							
8							
9							
10							
11							
12							
13							
14							
15							
16							
17							
18							
19							
20							

Delivery Total

Multiplier Total

Q Value Total

Helpful Tip:

The above worksheet is for designing an automatic cyclic system. When designing a continuous system, please contact Trico's customer service for assistance.

Product Selection Charts

INSTRUCTIONS - Find the Flow Rate value for each lubrication point. This corresponds to the flow rate values in the Meter Units chart. Select the mounting configuration best suited for the application. Additional information regarding the mounting configuration is found on the opposite page.

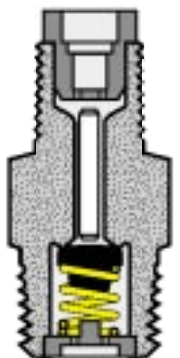

↑ FLOW DIRECTION ↓

METER UNITS

Flow Rate	5/16-24 x 5/16-24	5/16-24 x 1/8 NPT	1/8 NPT x 1/8 NPT	M8 x 1.0 x M8 x 1.0	M8 x 1.0 x 1/8 BSPT	1/8 BSPT x 1/8 BSPT
3/0	DSM-3/0	DCM-3/0	DTM-3/0	-	-	-
00	DSM-00	DCM-00	DTM-00	DSM-00M	DCM-00M	DTM-00M
0	DSM-0	DCM-0	DTM-0	DSM-0M	DCM-0M	DTM-0M
1	DSM-1	DCM-1	DTM-1	DSM-1M	DCM-1M	DTM-1M
2	DSM-2	DCM-2	DTM-2	DSM-2M	DCM-2M	DTM-2M
3	DSM-3	DCM-3	DTM-3	DSM-3M	DCM-3M	DTM-3M
4	DSM-4	DCM-4	DTM-4	DSM-4M	DCM-4M	DTM-4M
5	DSM-5	DCM-5	DTM-5	DSM-5M	DCM-5M	DTM-5M

CONTROL UNITS

Flow Rate	5/16-24 x 5/16-24	5/16-24 x 1/8 NPT	1/8 NPT x 1/8 NPT	M8 x 1.0 x M8 x 1.0	M8 x 1.0 x 1/8 BSPT	1/8 BSPT x 1/8 BSPT
5/0	DSC-5/0	DCC-5/0	DTC-5/0	-	-	-
4/0	DSC-4/0	DCC-4/0	DTC-4/0	-	-	-
3/0	DSC-3/0	DCC-3/0	DTC-3/0	-	-	-
00	DSC-00	DCC-00	DTC-00	-	-	-
0	DSC-0	DCC-0	DTC-0	-	-	-
1	DSC-1	DCC-1	DTC-1	DSC-1M	DCC-1M	DTC-1M
2	DSC-2	DCC-2	DTC-2	DSC-2M	DCC-2M	DTC-2M
3	DSC-3	DCC-3	DTC-3	DSC-3M	DCC-3M	DTC-3M
4	DSC-4	DCC-4	DTC-4	DSC-4M	DCC-4M	DTC-4M
5	DSC-5	DCC-5	DTC-5	DSC-5M	DCC-5M	DTC-5M

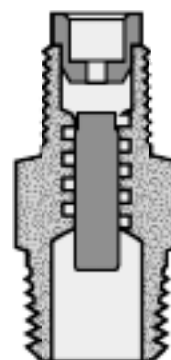

↑ FLOW DIRECTION ↓

INSTRUCTIONS - Find the total oil required for all lubrication points. Select a pump that is in the desired flow range. Refer to the Trico catalog for information on the specific features of the different pumps.

SELECTION CHART FOR AUTOMATIC CYCLIC PUMPS

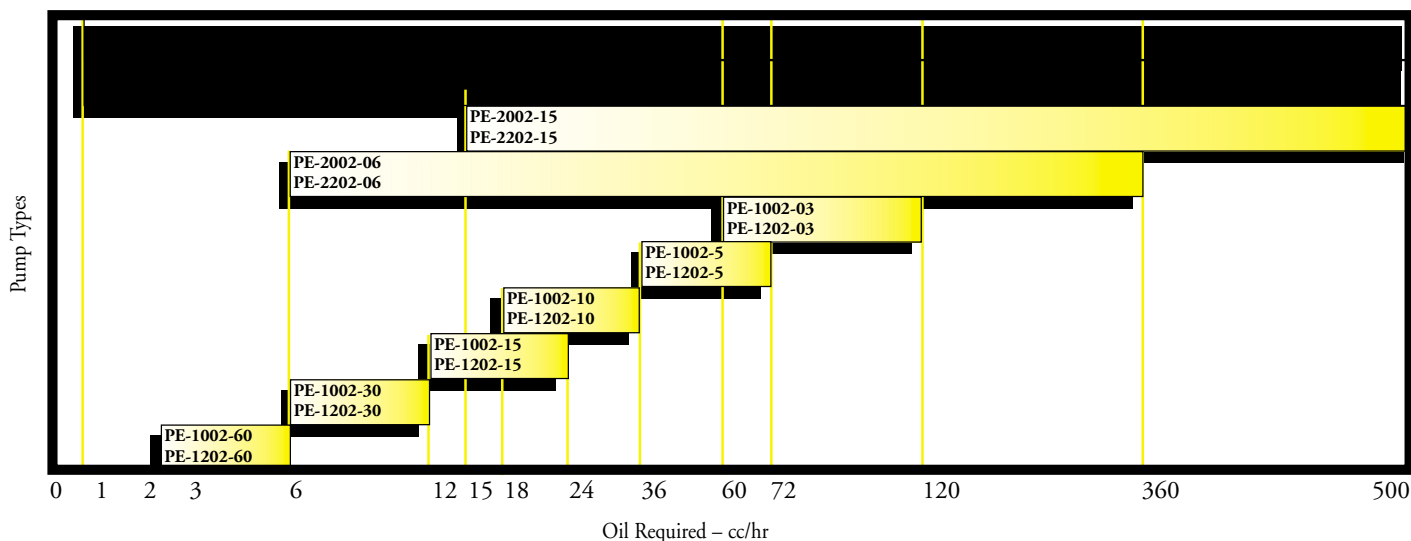

Distribution Network Design

Selecting the distribution network components begins with a sketch or layout of the system. Hardware will be different when the lubrication points are some distance apart or are close together. Many systems will be combinations of distant and close lubrication points. The general sequence is A) Select the pump location B) determine how your meter units or control units will mount at each point and C) develop interconnecting plumbing.

A. Pump Location

Several key considerations are:

1. Install the pump to be visible to the machine operator or maintenance person. This will simplify checking lubricant levels.
2. Make sure that there is easy access for refilling the reservoir.
3. Access to electricity for automatic pumps should be convenient and safe.
4. Generally, the pump is mounted lower than the majority of the points being lubricated to avoid trapped air.

B. Meter Unit or Control Unit Installation

There are three mounting options to choose from in both meter units and control units.

1. Direct Mounting

In these applications, the meter or control unit is connected directly to the lubrication point and a single line is connected to it (fig. 1). One end of the meter or control unit is NPT or BSPT and the other end is a 5/16-24 or metric straight thread.

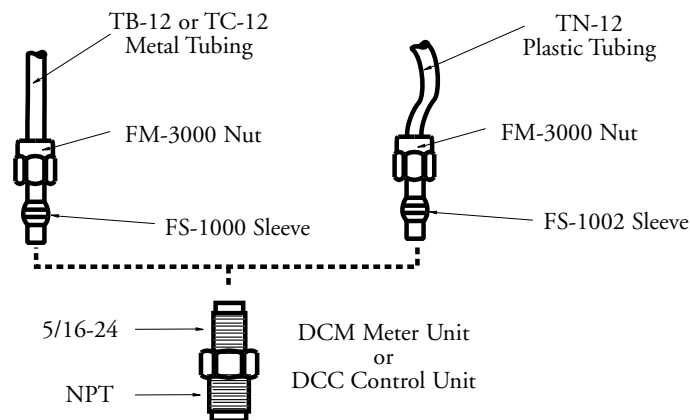

Figure 1

2. Tee Mounting

In these applications, the meter or control unit is connected directly to the lubrication point and a junction is connected on the other end (fig. 2). Both ends of the meter or control unit are NPT or BSPT.

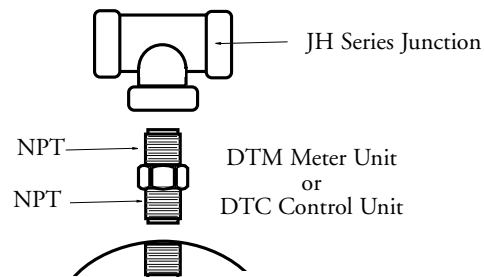
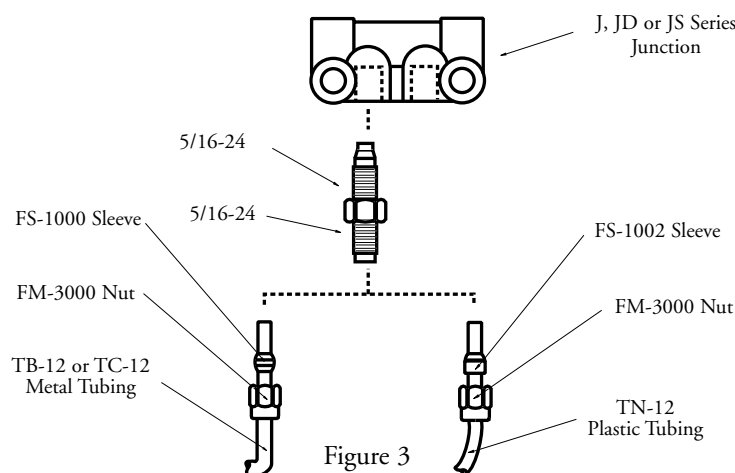

Figure 2

Distribution Network Design

3. Remote Mounting

In these applications, the meter or control unit is not connected to the lubrication point. One end of the meter or control unit is connected to a junction, and the other end is connected to tubing that goes to the lubrication point (fig. 3). Both ends of the meter or control unit are 5/16-24 or metric straight threads.



C. Interconnecting Plumbing

There are several considerations to make when connecting a central lubrication system.

1. Tubing Type - Metal or plastic tubing are the 2 choices available. When using metal tubing, copper tubing is the easiest to install. Steel is stronger, but more difficult to install.
2. Hoses - When connecting lubrication points that move, the use of a hose is recommended. Allow adequate hose length to prevent kinking, stretching, or twisting.
3. Tubing Fittings - Refer to figures 1, 2, and 3 for examples of how the tubing fittings connect. When connecting tubing to a female thread, use the FM-1000 series bushings in place of the FM-3000 series nuts (fig. 4).

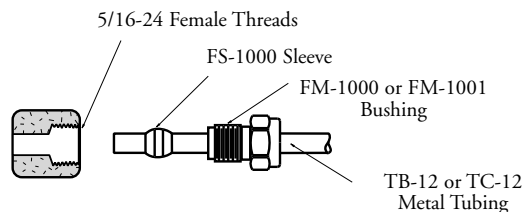

4. Pressure gauges - Pressure gauges should be installed in central lubrication systems to verify that adequate oil pressure is getting to each lubricant point. Depending on the size of the system, one or more gauges may be installed at different points. A gauge installed at the furthest point from the pump is useful in determining if the entire system is receiving adequate oil pressure.
5. Check valves - Check valves are used to hold pressure in a line and prevent dripping and leaking. Meter units contain internal check valves, and control units do not need check valves because of the constant flow. Separate check valves can be installed when the meter unit is not located at the point of lubrication. Installing the check valve between the meter unit and the lubricant point will maintain an oil supply in the lubrication line.

Introduction to Minimum Quantity Lubrication

For over a decade, the concept of minimum quantity lubrication, sometimes referred to as “near dry machining”, has been suggested as a means of addressing environmental concerns and occupational hazards associated with airborne mist. In most instances, when cutting fluids are used, an airborne mist is released into the air that eventually falls to shop floors, causing concern for employee health and safety. By minimizing the use of cutting fluids economical benefits can be achieved; such as reduced costs of lubricant and disposal, as well as machine and workpiece cleaning time.

WHAT IS MINIMUM QUANTITY LUBRICATION?

The basic principal of minimum quantity lubrication is the utilization of precision dispensers to apply the smallest amount of lubricant (typical applications use 1 oz. of lubricant in an 8-hour shift) needed to effectively perform the metal cutting operation. These dispensers help eliminate friction at the tool chip interface by minimizing the heat that can be generated. Special lubricants, such as Tri-Cool MD-1 and MD-7, are used with these dispensers which are virtually consumed during the machining operation, resulting in residue-free machine surfaces and work pieces, and the elimination of airborne mist.

BENEFITS OF MINIMUM QUANTITY LUBRICATION:

When using minimum quantity lubrication dispensers, the following benefits will be achieved:

- Increased tool life
- Increased material removal
- Improved tolerances
- Improved surface finish
- No sump maintenance
- Less machine downtime
- No coolant disposal costs
- Higher resale value of chips
- Elimination of airborne mist



Minimum quantity lubrication used on a horizontal saw.



Minimum quantity lubrication used during a milling operation.

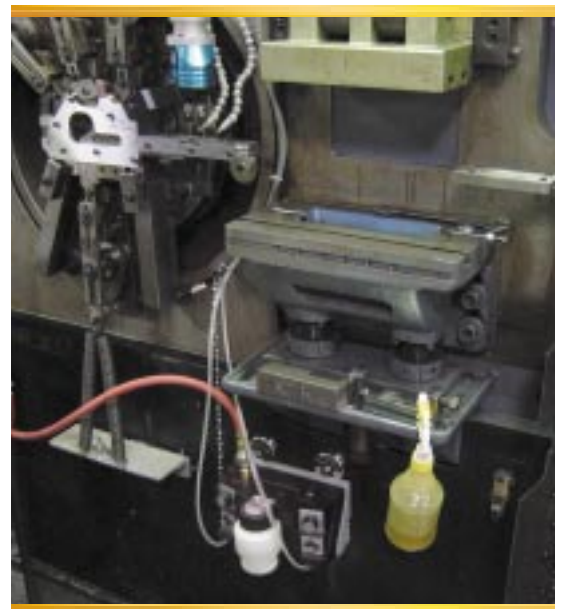

Minimum quantity lubrication used in a tapping workcenter.

MD-1200 Micro-Drop[®]



30802

APPLICATIONS:

The MD-1200 Micro-Drop dispenser provides a cost effective solution when flood cooling is impractical or unavailable. When used in milling, tapping, and sawing applications, the MD-1200 dispenses small amounts of Tri-Cool Micro-Drop synthetic or vegetable based lubricant. Compared to flood cooling, there is no coolant sump to maintain or used coolant to dispose of. The MD-1200 offers higher material removal rates, improved part finish, longer tool life, and tighter dimensional tolerances.

Solenoid versions allow these units to be interfaced with CNC controls or other signaling devices. The pressurized delivery system of the MD-1200, provides instant on/off performance when used with the solenoid control.

Control module versions replace the air and liquid controls at the unit with controls located at the nozzle. This allows the operator to easily adjust the air and liquid settings in toolroom applications.

SPECIFICATIONS

System Type	Pressure Delivery, Non-Cyclic
Delivery Lines	6 ft. Polyurethane
Nozzles	18" Loc-Line or 13" Copper
Liquid Flow Range	2-16 Drops/Minute
Liquid Viscosity	50-200 SUS
Inlet Air Pressure	60-125 PSI
Recommended Air Filter	40 Micron
Air Consumption	1.7 CFM/Line
Air Inlet Fitting	1/4 NPT*
Solenoid Voltages	120V 60Hz
Dimensions	7.06" H x 10.09" W x 7.06" D
Reservoir Capacity	16 oz.

* Metric connection port available. Add "-M" to part number for 1/4 BSPT connection port.

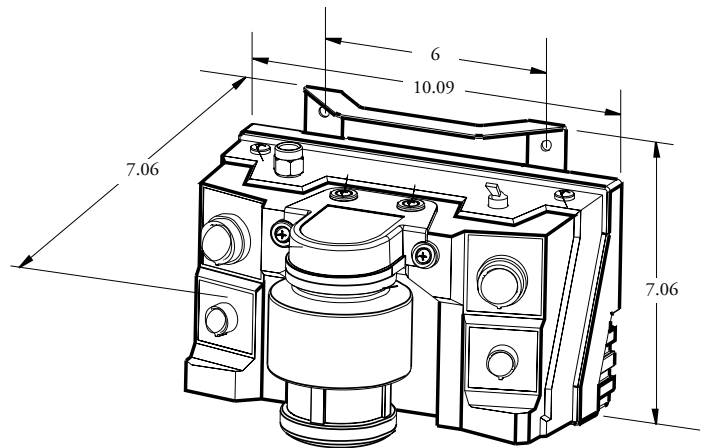

SELECTION CHART

Model No. with Loc-Line Nozzles	Model No. with Copper Nozzles	Description
30801	30813	1 Line, Manual On/Off
30802	30814	2 Line, Manual On/Off
30803	30815	1 Line, Manual On/Off, Control Module
30804	30816	2 Line, Manual On/Off, Control Module
30805	30817	1 Line, Solenoid On/Off
30806	30818	2 Line, Solenoid On/Off
30807	30819	1 Line, Solenoid On/Off, Control Module
30808	30820	2 Line, Solenoid On/Off, Control Module

Helpful Tip:

The MD-1200 Micro-Drop should not be used with a water-soluble coolant. These types of fluids will damage and clog system components. Trico offers a line of lubricants that is ideal for use with the MD-1200. Please see Tri-Cool Fluids document for Tri-Cool MD-1 and MD-7.

MD-1200 Micro-Drop[®]

OPTIONS

Control

Module Replaces the air and liquid controls at the unit with controls located at the nozzle. When air and liquid adjustments are made frequently, this can save operator time and simplify the work.



Copper Nozzles replace the flexible plastic lines in applications where the nozzle position is fixed. Copper nozzles are supplied straight, and are easily bent to the desired nozzle position.



Magnetic Mounting Kit - Model No. 30687

Simplifies mounting when used in portable applications.

Typical applications use 1 oz. of lubricant in an 8-hour shift.

Positive pressure design gives instant fluid delivery for faster cycle times.

The MD-1200's anti-siphon valves permit the nozzles to be mounted in any position.

Relative liquid scale allows repeatable set-ups and saves time in adjusting flow rates for different applications.

Independent controls allow for maximum flexibility in adjusting liquid and air flow for each nozzle.

Simple easy-to-use controls. No confusing timer to set.

High energy nozzle design eliminates fogging for cleaner environment and greater chip clearing power, allowing faster speed and feeds.



Nozzle Manifold for Band Saws - Model No. 30850

This nozzle manifold is designed to improve installations on band saws. The manifold is easily installed to a user supplied mounting bracket, and replaces either the plastic nozzles or copper nozzles. Benefits to the user are simplified installation and longer lasting nozzle positioning.

Replacement Nozzle Tip

Model No.	Description
20024R	Nozzle Tip for Plastic or Copper Nozzle

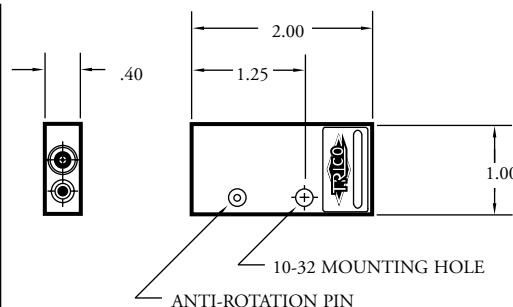

Introduction to Spray Cooling

The need for providing coolant to metal removal operations is readily accepted in machining industries. Spray cooling provides the benefits of coolants used in flood applications with the added performance of a high velocity air/coolant mixture. It is used where high speed tools and saw blades require powerful chip clearing, and offers coolant application where flood cooling is inadequate. In addition, spray cooling is also used in processes that generate high amounts of heat at the tool chip interface. Delivering a low volume of coolant at a high velocity, spray cooling is able to remove heat as fast as possible, which is critical in maximizing productivity and quality. Also, it helps keep expendable tooling costs in line. Trico offers three separate types of delivery systems for dispensing a wide range of coolants in many metal removal processes: siphon, pump, and pressure delivery.

SIPHON DELIVERY SYSTEMS -

Siphon type units use the flow of air across an orifice to draw or pull fluid from the reservoir to the nozzle tip. There are no moving parts. These siphon type units cover a range of applications from light to moderate with up to six nozzle capability. The use of multiple nozzles allows adequate coverage when tool sizes are large or heat generation is great. Typical locations for use would be machine shops, tool rooms, prototype areas, or small machining work cells. These units are economically priced and can cover secondary machining applications not equipped with coolant capabilities. Drilling, tapping, milling, turning, sawing, etc. are examples of applications that can be improved with the various siphon units that are offered.

PUMP AND PRESSURE DELIVERY SYSTEMS -

For more sophisticated and demanding metal removal processes, or where more than six nozzles are necessary, the pump or pressure type delivery systems are recommended. These are also recommended for higher viscosity fluids, up to 1000 SUS. The pump type uses a mechanical pump to force fluid from the reservoir and the pressure type uses an air pressurized reservoir to force fluid to the nozzles. With the coolant being delivered with positive pressure in either case, a wide range of coolant stream definition can be attained. From air only to mini-flood streams, the wide range

available for adjustment, allows the user to set delivery to the specific application requirements. Applications covered by these systems include dedicated secondary machines, transfer lines, conveyors, large capacity tooling, through the tool and machining cells. The multiple nozzle/valve combinations also allow for customizing systems specific to end user applications.



Spray cooling during milling operation.

METAL REMOVAL FACTS

1. Metal removal methods generate friction. Two types of friction generate heat:

- a. External friction, where approximately a third of the heat is generated, metal to metal contact of the work tool to the work piece
- b. Internal friction, where approximately two-thirds of the heat is generated, resistance of metal atoms to movement when the metal is deformed in the shear zone

2. There are many variables at the interface of the tool and the work piece that influence the effectiveness of your cut.

- a. Tool material, tool design, tool size, speed of tool, depth of cut, feed rate, work piece material, type of operation, type of equipment, and coolant/lubricant method are just some of these variables.

3. Equipment, operation, tooling, material, part quantity, secondary operations, and safety could dictate the method of cooling/lubricating to use.

- a. Equipment - flood system ready, compressed air
- b. Operation - milling, drilling, tapping, sawing, etc
- c. Tooling - carbide, diamond, ceramics, special coatings
- d. Material - brass, aluminum, steel, stainless, plastics
- e. Part quantity - one to ten, short runs, long runs(cycle time)
- f. Secondary operations - plating, anodizing, painting, machining
- g. Safety - work piece handling in fixtures or chucking, work area

4. There is no single method that works best in all metalworking applications

- a. Cutting fluids do one or more of the following functions:
 - i. Cool the tool, work piece and chip
 - ii. Reducing friction by minimizing erosion of the tool by lubricating
 - iii. Remove chips from the work area
 - iv. Protect the work piece, tooling and machine from corrosion

5. The application method needs to apply the fluid properly to achieve any or all of the above functions economically

6. Spindle speed, feed rate and depth of cut can also determine your method

- a. Spindle speed, high, intermediate, low - cool or lubricate
 - i. High speed requires more cooling
 - ii. Intermediate speeds require both cooling and lubricating
 - iii. Low speeds require more lubricating
- b. Feed rate
 - i. Quicker feed rates generate more heat and requires more cooling
 - ii. Slow feed rates require more lubricating
- c. Depth of cut
 - i. Chip evacuation, cooling and lubricating required

DL & DL Magnum

APPLICATIONS:

The DL and DL Magnum spray cooling systems provide cooling solutions for light duty machining and tool room applications. These dispensers are easy to install requiring only shop air and dropping the siphon line into a coolant tank.



FEATURES:

DL

- Siphon delivery system.
- 7 in. flexible segmented nozzle.
- Solid brass precision needle valve and body.
- 7 ft. coolant pickup line with stainless steel filter.
- Sturdy 60 lb. magnetic base with mounting arm.
- Assembles in less than five minutes.

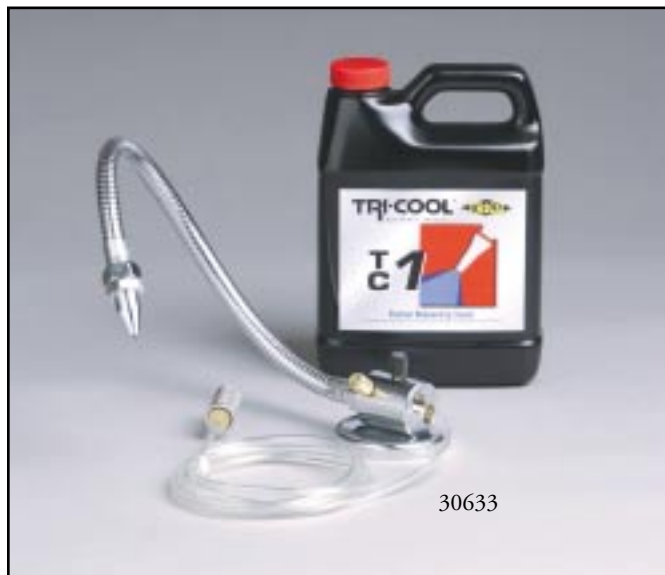

DL Magnum

- Siphon delivery system.
- 15 in. heavy duty metal nozzle conduit.
- Advanced nozzle design for increased chip clearing power and reduced overspray.
- Independent air and liquid controls.
- 6 ft. coolant pickup line with stainless steel filter.
- Sturdy 60 lb. mounting magnet.
- Check valve minimizes delay of fluid upon start-up.
- BSPT threads (green model numbers) are available.

SPECIFICATIONS

	DL	DL Magnum
Valve Body	Brass	Plated Brass
Seals	Buna-N	Buna-N
Siphon Line	Polyurethane	Polyurethane
Filter Element	40 x 40 Mesh Stainless Steel	40 x 40 Mesh Stainless Steel
Air Inlet Pressure	50-100 PSI	60-120 PSI
Air Inlet Fitting	1/8 NPT	1/4 NPT or 1/4 BSPT
Fluid Type	Water based coolants suitable for spray cooling.	Water based coolants suitable for spray cooling.

SELECTION CHART

Model No.	Description
30660	DL Dispenser
30655	DL Dispenser w/ 1 qt. Tri-Cool Coolant
30632	DL Magnum Dispenser, 1/4 NPT
30633	DL Magnum Dispenser w/ 1 qt. Tri-Cool Coolant, 1/4 NPT
30634	DL Magnum Dispenser, 1/4 BSPT
30635	DL Magnum Dispenser w/ 1 qt. Tri-Cool Coolant, 1/4 BSPT

Li'l Mister Systems



APPLICATIONS:

Li'l Mister systems offer spray cooling with features normally available with higher cost units. The compact size with a 1 quart reservoir makes the Li'l Mister ideal for tool room and other light duty machining applications. Typical applications include drilling, milling, turning, grinding, and tapping.

FEATURES:

- Siphon delivery system.
- Easy reading sight gauge.
- 5 ft. plastic or brass armored line.
- Easy mounting bracket.
- Independent air/coolant adjustability.
- One quart reservoir capacity.
- 6 in. straight brass nozzle standard.
- Size - 8 1/2" H x 5 1/4" W x 4" D

SPECIFICATIONS

Reservoir	High Density Polyethylene
Sight	Acrylic Plastic
Valves	Brass
Seals	Buna-N
Delivery Line	5 ft. Brass or Plastic
Coolant Tube	Polyurethane
Filter Element	40 x 40 Mesh Stainless Steel
Air Inlet	1/4 NPT
Air Inlet Pressure	50-100 PSI

Helpful Tip:

The Li'l Mister is designed to be used with a water-soluble coolant. See Tri-Cool Fluids document.

SELECTION CHART

Model No.	Capacity (qts.)	No. of Lines	Line Length (ft.)	Line Material
30540	1	1	5	Plastic
30541	1	1	5	Brass

ACCESSORIES

Magnetic Nozzle Holders

Magnetic nozzle holders facilitate the placement and directing of the nozzle.

Model No.	Description
30460	30 lb. Holder
30630	60 lb. Holder
30142	165 lb. Holder



Nozzles

Model No.	Length	Type
30490	6"	Straight
30491		45° Angled
30492		90° Angled
30493		Flexible Loc-Line

"SST" Spray Coolant Systems



30546

APPLICATIONS:

"SST" coolant systems offer spray cooling with features normally costing much more. This unit is designed for production type applications where less frequent filling is desirable. Quality construction is evident in the heavy duty, stainless steel reservoir. These units can stand alone for portability or be permanently mounted to any machine application.

SPECIFICATIONS

Reservoir	Type 304 Stainless Steel, 20 gauge
Cover	High Density Polyethylene
Valves	Brass
Seals	Buna-N
Delivery Line	5 ft. Plastic
Coolant Tube	Polyurethane
Nozzle	Brass
Filter Element	40 x 40 Mesh Stainless Steel
Air Inlet	1/4 NPT
Air Inlet Pressure	50 - 100 PSI

ACCESSORIES

Nozzles

A straight nozzle is supplied as standard. It also may be ordered separately.

Model No.	Length	Type
30490	6"	Straight
30491		45° Angled
30492		90° Angled
30493		Flexible Loc-Line

FEATURES:

- Siphon delivery system.
- Heavy duty 20 gauge, all welded, stainless steel reservoir.
- 1 gallon reservoir capacity.
- Independent air and coolant control for wide delivery range.
- Rugged, one piece molded high density polyethylene cover for easy filling and cleaning.
- Solid brass fittings.
- 6 in. brass nozzle standard.
- 1 or 2 outlet, 5 ft. plastic lines.
- Includes mounting bracket.
- Size - 8 7/8" H x 8 3/8" W x 5 5/32" D

Helpful Tip:

The "SST" coolant system is designed to be used with a water-soluble coolant. See Tri-Cool Fluids document.

SELECTION CHART

Model No.	Capacity (gal.)	No. of Lines	Length of Lines (ft.)
30546	1	1	5
30547	1	2	5

Magnetic Nozzle Holders

Magnetic nozzle holders facilitate the placement and directing of the nozzle.

	Model No.	Description
	30460	30 lb. Holder
	30630	60 lb. Holder
	30142	165 lb. Holder

Spraymaster

APPLICATIONS:

Spraymaster systems provide convenient spray cooling in metal cutting. Requiring only compressed air as a power source, these units are easily installed in many machining applications.

The Spraymaster is designed for use with Tri-Cool synthetic coolant. Various mixtures of coolant to water may be used depending upon individual requirements.

Stainless steel reservoir versions are available with the same performance features as the standard Spraymaster.

FEATURES:

- Siphon delivery system.
- Air and coolant are independently controlled by solid brass precision needle valves.
- Brass armored lines are a standard 5 foot length.
- 6 in. straight brass nozzle is designed so atomization takes place at nozzle tip for enhanced pattern control.
- Mounting brackets included for easy installation.
- 1 or 2 outlet line models provide maximum flexibility.
- Liquid level gauge easily indicates coolant level at a glance.
- Polyethylene dimensions: 12-1/4"H x 10"W x 5-1/4" D
- Stainless steel dimensions: 9-3/8"H x 8-3/8"W x 5-1/4"D



SPECIFICATIONS

Cover	High Density Polyethylene
Reservoir	High Density Polyethylene or 20 Gauge 304 Stainless Steel
Valves	Brass
O-Rings	Buna-N
Delivery Line	Brass Armored
Coolant Tube	Polyurethane
Fittings	Brass
Filter Element	40X40 Mesh Stainless Steel
Air Inlet	1/4 NPT

SELECTION CHART

Model No.	Reservoir Type	Capacity (gals.)	No. of Lines	Line Length (ft.)
30542	High Density Polyethylene	1	1	5
30543			2	
30548	Stainless Steel		1	
30549			2	

Helpful Tip:

SprayMaster units are designed to be used with a water-soluble coolant. See Tri-Cool Fluids document.

ACCESSORIES

Nozzles

Spraymasters are supplied with straight nozzles. Other nozzle types are available for customer installation.

Model No.	Length	Type
30490	6"	Straight
30491		45° Angled
30492		90° Angled
30493		Flexible Loc-Line

Magnetic Nozzle Holders

Magnetic nozzle holders facilitate the placement and directing of the nozzle.

	Model No.	Description
	30460	30 lb. Holder
	30630	60 lb. Holder
	30142	165 lb. Holder

Spraymaster II



30458

FEATURES:

- Siphon delivery system.
- High performance 7 in. flexible segmented plastic nozzle.
- Solenoid control for instantaneous response.
- 1 or 2 outlet, 5 ft. brass armored lines.
- Easy to read coolant sight gauge.
- Easy to mount reservoir bracket for permanent mounting to application.
- Independent air and coolant controls for lean to rich spray delivery.
- Size: 12-1/4"H x 10"W x 5-1/4"D

APPLICATIONS:

The SprayMaster II is designed for applications where the ability to cycle the delivery is required. Solenoid control of spray coolant allows instant on-off operation for use in fixtured secondary machining. Solenoid control also conserves on coolant use during load and unload portion of cycle. This model is available with two lines for maximum coolant delivery or pattern control. The Spraymaster II can be interfaced with a wide range of signaling devices for automatic delivery applications.

Helpful Tip:

SprayMaster II units are designed to be used with a water-soluble coolant. See Tri-Cool Fluids document.

SELECTION CHART

Comes complete with UL and CSA approved 110 volt, 60 Hz power cord. Fused and fully grounded.

Model No.	Capacity (gal.)	No. of Lines	Length of Lines (ft.)
30458	1	1	5
30459	1	2	5

SPECIFICATIONS

Reservoir	High Density Polyethylene
Sight	Acrylic Plastic
Valves	Brass
Seals	Buna-N
Delivery Line	5 ft. Brass Armored
Coolant Tube	Polyurethane
Filter Element	40 x 40 Mesh Stainless Steel
Solenoid	Brass Body & S/S Plunger
Air Inlet	1/4 NPT
Air Inlet Pressure	50 - 100 PSI

ACCESSORIES

Nozzles

Model No.	Length	Type
30260	6"	Straight
30622	7"	Flexible Plastic
30623	12"	

Magnetic Nozzle Holders

Magnetic nozzle holders facilitate the placement and directing of the nozzle.

Model No.	Description
30460	30 lb. Holder
30630	60 lb. Holder
30142	165 lb. Holder

Type "B" Spray Coolant Systems



30550

APPLICATIONS:

This system provides spray coolant delivery at up to six separate locations. Each line can be individually set for exact delivery. Independent air and coolant controls enable users to balance the delivery of coolant to each application. Type B models are suited to applications where multiple cutting locations, large diameter tools or higher heat transfer requirements are desired.

FEATURES:

- Siphon delivery system.
- Large five gallon polyethylene reservoir.
- 1 to 6 outlet, 5 ft. armored brass delivery lines.
- 6 in. straight brass nozzles.
- Independent line control for multiple requirements.
- Independent air and coolant control for a wide range of delivery requirements.
- Reservoir handle for portability.
- Size - 15"H x 12 3/8" Diameter

Helpful Tip:

Type "B" spray coolant systems are designed to be used with a water-soluble coolant. See Tri-Cool Fluids document.

SELECTION CHART

Model No.	Capacity (gals.)	No. of Lines	Length of Lines (ft.)
30550	5	1	5
30551		2	
30552		3	
30553		4	
30554		5	
30556		6	

ACCESSORIES

Nozzles

Model No.	Length	Type
30490	6"	Straight
30491		45° Angled
30492		90° Angled
30493		Flexible Loc-Line

Magnetic Nozzle Holders

Magnetic nozzle holders facilitate the placement and directing of the nozzle.

	Model No.	Description
	30460	30 lb. Holder
	30630	60 lb. Holder
	30142	165 lb. Holder

Mistmatic[®] Coolant Delivery Systems

APPLICATIONS:

The Mistmatic allows the user a wide range of coolant delivery. Variable adjustability allows deliveries such as lean, rich, high velocity, or low velocity. Unit can fill “mini-flood” applications with the dual control valving. This unit can cover most machining requirements. Multiple metal removal processes ranging from broaching to grinding can be covered with the Mistmatic. The pressure pumping design of the Mistmatic allows use with a wide range of coolants compatible with Buna-N seals and lower than 1000 SUS viscosity. Auto electric models can be interfaced with machine controls for cyclic capabilities.

FEATURES:

- Pump operated system.
- HV-3100 control valve with 7 in. segmented plastic nozzle.
- One or two outlet, 5 ft. brass armored lines.
- Independently adjusted air and coolant allows for balancing coolant delivery.
- Platform design capabilities allow for flexible line/nozzle combinations (consult factory).
- Easy reading sight gauge.
- 1 and 4 gallon reservoir capacities.
- Reservoir bracket for easy mounting directly to machining application.
- 1 gallon dimension = 10 1/2" H x 8 1/2" W x 6" D
4 gallon dimension = 14 1/2" H x 17 1/2" W x 9" D

Nozzles

Model No.	Length	Type
30250	3"	Straight
30254		45° Angled
30251	6"	Straight
30255		45° Angled
30259		90° Angled
30253	12"	Straight
30257		45° Angled
30261		90° Angled
30268	7"	Flexible Metal
30267		Flexible Plastic
30620	12"	
30621		



SPECIFICATIONS

Reservoir	High Density Polyethylene
Sight	Acrylic Plastic
Check Valve	Brass w/Buna-N Seals
Seals	Buna-N
Delivery Lines	5 ft. Armored Brass
Coolant Tube	Polyurethane
Valves	Brass
Solenoid	Brass Body & S/S Plunger
Nozzle	Flexible Segmented Plastic Standard
Pump	Acetal Copolymer w/Buna-N
Tubing	Polyurethane
Air Inlet	1/4 NPT
Air Inlet Pressure	50 -100 PSI

SELECTION CHART

Model No.	Capacity (gal.)		No. of Lines	Control Mode	Voltage (VAC)
	Plastic	Stainless			
30600	1	-	1	Manual	-
30601	1	-	2	Manual	-
30602	4	-	1	Manual	-
30603	4	-	2	Manual	-
30604	1	-	1	Auto	120*
30605	1	-	2	Auto	120*
30606	4	-	1	Auto	120*
30607	4	-	2	Auto	120*
30608	-	1	1	Manual	-
30609	-	1	2	Manual	-
30610	-	1	1	Auto	120*
30611	-	1	2	Auto	120*
30614	1	-	Customer Specified	Manual	-
30615	4	-		Manual	-

*Other voltages on request

Coolant Delivery Systems

APPLICATIONS:

Both the 30034 and 30095 systems cover coolant delivery applications ranging from single point applications to multiple point (up to 100) applications. With the use of a variety of signaling devices, custom machining application cooling and lubricating can be accomplished. With the nozzle/valve designs available, individual machine and tool requirements can be serviced from one platform design tank or pump. The dual control valves allow a delivery range from air only, to mini-flood, and a variety of spray streams. Applications ranging from broaching to grinding are covered using these combinations.

FEATURES:

30034 Dispenser

- Pressure delivery system.
- 5 gallon stainless steel ASME certified tank.
- Cam action fill cover cannot be opened when unit is pressurized.
- Large opening for filling.
- Air regulator, gauge, coolant filter, pressure relief valve and two way shut off valve included.

30095 Pump

- Pump operated system.
- Large capacity delivery capability - up to 100 individual nozzles.
- Pump works on stall pressure as coolant is delivered saving compressed air.
- Pump installs into 2 in. bung in drums or tank allowing quick changeover of coolant supply.
- Air only needed for operation.
- Air regulator, gauge, coolant filter, quick-disconnects and fittings included.

Control Valves

- Solid brass valve construction.
- Precision needle valves allow for infinite pattern delivery.
- Valve and nozzle design allows for multiple delivery potential.
- Fast acting solenoids allow cyclic application for conserving coolant and compressed air and maintaining work environment.
- P-12A has built-through feature for simplified installation with other valves.
- HV-2100 has valve controls close to nozzle delivery point.



30034

30095

SELECTION CHART

Model No.	Description
30034	5 Gallon Dispenser
30095	1:1 Ratio Pump - 2" Bung Fitting

Coolant Delivery Systems

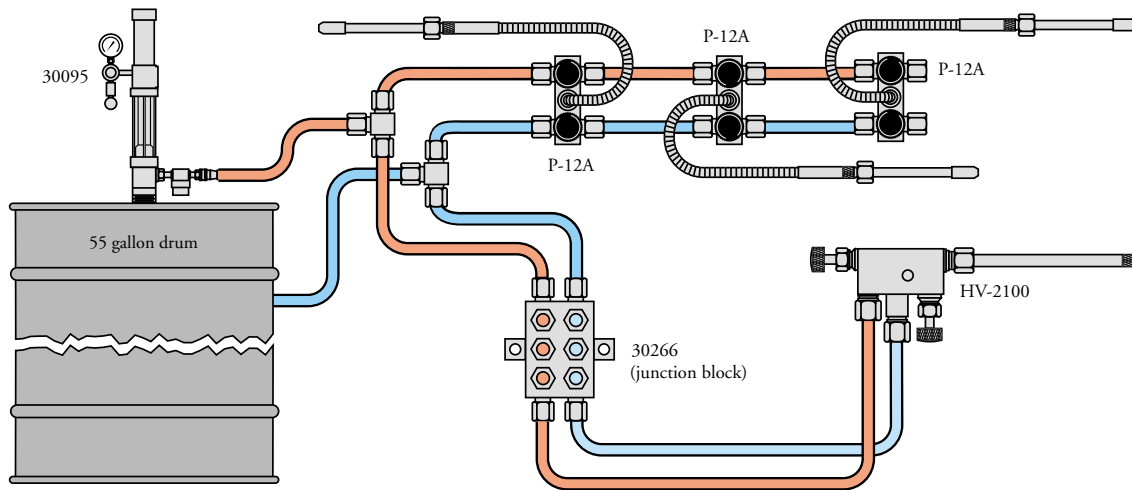

SPECIFICATIONS - PUMPS/DISPENSERS

	30034	30095
Material	Type 304 Stainless Steel	Carbon Steel
Capacity	5 gal.	Reservoir Size
Seals	Buna-N	Viton® and Teflon
Packing	-	Polyethylene
Fitting	Brass	
Filter	40 x 40 Mesh Stainless Steel	
Controls	0-100 PSI Regulator and Gauge	
Size	24 1/2" x 9"	51" x 10"
Connections	1/4 NPT Quick Coupling Inlet 1/4" O.D. Tube Outlet	1/4 NPT Quick Coupling Inlet 3/8" Quick Coupling Outlet
Air Pressure	50-100 PSI	

SELECTION CHART

CONTROL VALVES

Model No.	Type	Nozzle
30240	HV-2100	3" Straight
30241		6" Straight
30243		12" Straight
30248		7" Flexible Metal
30249		12" Flexible Metal
30256		7" Flexible Plastic
30258		12" Flexible Plastic
30112		P-12A



Nozzles

Model No.	For Use With	Length (in.)	Type
30250	HV-2100	3	Straight
30251		6	
30253		12	
30254		3	45° Angled
30255		6	
30257		12	
30259		6	
30261		12	
30267		7	Flexible
30268		12	Metal
30125	P-12A	4	Straight
30126			45° Angled
30127			90° Angled

HOW TO ORDER: Most systems require the following minimum components: dispenser, control valve, fittings, and tubing.

Introduction to Lubricants & Coolants

Cutting fluids play a significant role in machining operations and impact shop productivity, tool life and quality of work. The primary function of a cutting fluid is temperature control through cooling and lubrication. A fluid's cooling and lubrication properties are critical in maximizing productivity and quality, in addition to keeping expendable tooling costs in line. Cooling and lubrication are also important in achieving the desired size, finish and shape of the workpiece. A secondary function of a cutting fluid is to flush away chips and metal fines from the tool/workpiece interface. Ultimately, this prevents a finished surface from becoming marred and reduces the occurrence of a built-up edge.

Typically, cutting fluids are manufactured with the following bases: mineral, vegetable or synthetic. Additives are added to the base oil to achieve specific performance parameters such as corrosion inhibitors, wetting agents, biocides, extreme pressure additives, and emulsifiers. Cutting fluids fall into two categories: water-soluble coolant or lubricant, each containing its' own unique properties.

Water-soluble coolants are cutting fluids engineered to carry heat away from the tool chip interface. Water is the best coolant agent, but has no lubricating ability and is susceptible to contamination. Water-soluble coolants include base oil along with additives to enhance waters' ability to disperse heat. They are generally used in high-speed cutting operations such as turning and milling. Lubricants, non-soluble, are used in metal cutting operations to reduce friction. They are used in low-speed cutting operations such as broaching and tapping.

Cutting fluids are widely utilized to optimize the process of machining operations such as turning, drilling, boring, grinding, milling, drawing, stamping, and sawing. The proper selection of a cutting fluid will provide benefits such as extended tool life, increased speeds and feeds, tighter tolerance capability, and improved finish.

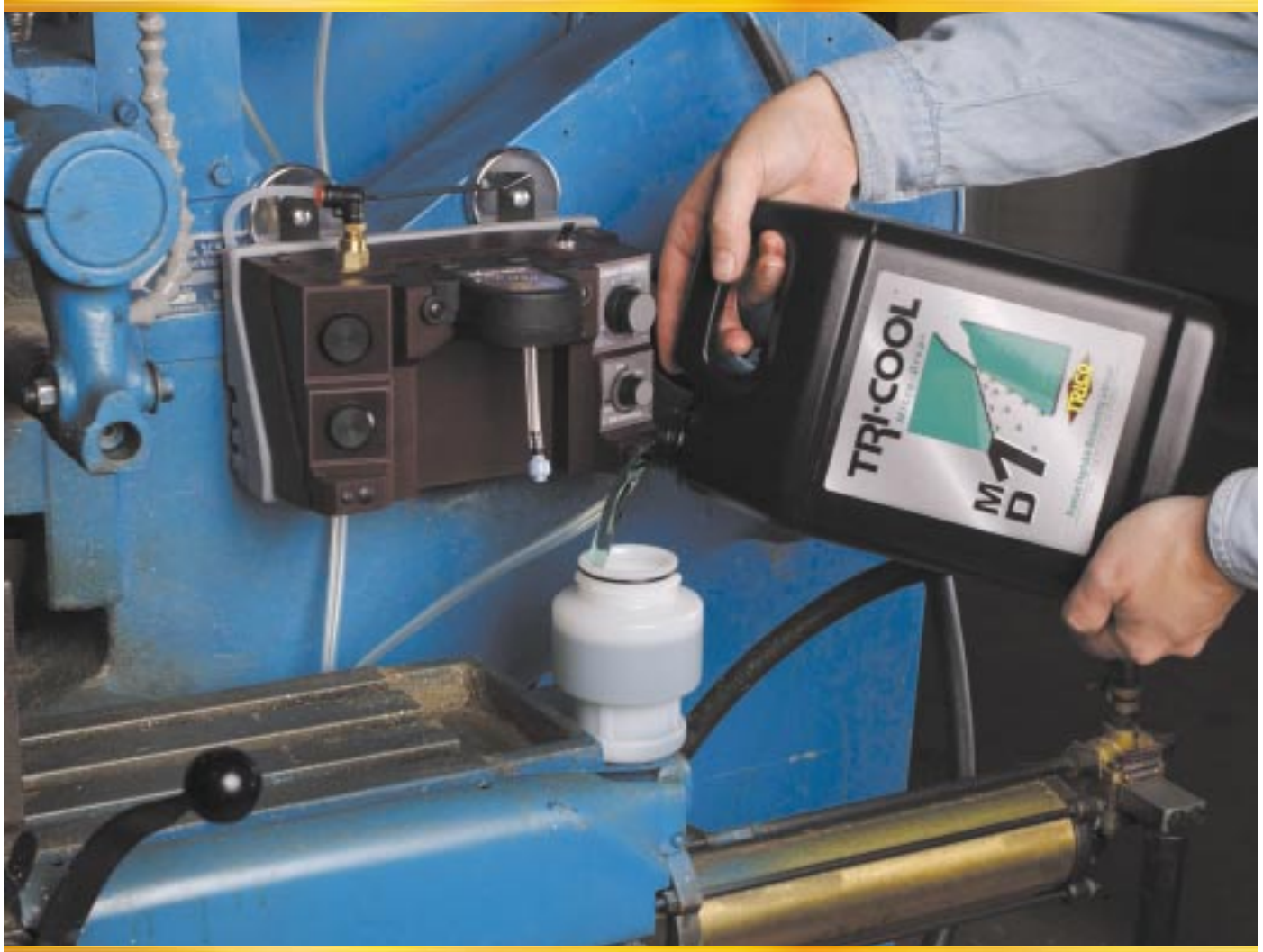

Micro-dispenser being filled with Tri-Cool MD-1 lubricant.

Tri-Cool® Fluids

Tri-Cool fluids are specially formulated to provide superior performance and long service life in various metal cutting operations on ferrous and non-ferrous metals. They have been designed to meet operator safety concerns. Tri-Cool fluids are safe to use, non-toxic, non-allergenic, and contain no harmful chemicals or additives.

- Maximize production rates • Maximize operating costs • Extend machine and tool life • Increase speeds and feeds • Increase productivity



TC-1 WATER-SOLUBLE COOLANT

TC-1 is a highly concentrated premium synthetic water-soluble coolant formulated to exceed the demands of spray and flood cooling. It contains a non-chlorine extreme pressure additive for improved tool and surface finish. TC-1 prevents rusting on tool and machine surfaces, even at lower concentrations. It contains a broad spectrum biocide/fungicide for protection against biological growth.

TC-1 is non-toxic, non-flammable, non-corrosive, and biodegradable.

Model No.	Size
30656	4 gallon / case
30657	5 gallon pail
30658	55 gallon drum

SUGGESTIVE DILUTION RATIOS

SPRAY COOLING		FLOOD APPLICATION	
Operation	Dilution Ratio	Operation	Dilution Ratio
Grinding	40:1	Light Machining	32:1
General Machining	32:1	General Machining	20:1
Broach, Tap, Heavy Mach.	20:1	Heavy Machining	10:1



MD-1 MICRO-DROP® VEGETABLE LUBRICANT

MD-1 is a pure vegetable based lubricant that can be used in various metal cutting operations to achieve effective machining productivity on ferrous and non-ferrous metals. MD-1 has a heat stable, non-chlorine extreme pressure additive for improved tool life and surface finish. MD-1 is low misting, to prevent fogging in the shop. It will not stain aluminum requiring post-heat treating. MD-1 is environmentally safe and biodegradable.

Model No.	Size
30648	4 gallon / case
30647	5 gallon pail
30646	55 gallon drum



MD-7 MICRO-DROP® SYNTHETIC LUBRICANT

MD-7 is a pure synthetic based lubricant designed for use in various metal cutting operations. With the use of a Micro-Dispensing system, more effective machining productivity and savings in fluid costs can be achieved, while waste and disposal problems are reduced. MD-7 is non-toxic, non-flammable, non-corrosive, and will not become rancid.

Model No.	Size
30659	4 gallon / case
30662	5 gallon pail
30663	55 gallon drum

Tri-Cool® Fluids

APPLICATION GUIDE (Micro-Dispensing lubricants)

All material used for data is 1018 Ø = diameter DOC = depth of cut

Process	Parameters	MD-1	MD-7
Milling (using a 1/2" Ø 2 flute HSS EM)	Up to 1/16 DOC	●	●
	From 1/16 to 1/4 DOC	●	●
	From 1/4 to 7/16 DOC	●	
Tapping	Up to 1/4 Ø	●	●
	From 1/4 Ø to 9/16 Ø	●	●
	From 9/16 Ø to 1 Ø	●	
Band Sawing	Up to 1 stock Ø	●	●
	From 1 to 3 stock Ø	●	●
	From 3 to 4 stock Ø	●	

APPLICATION CHART

		TC-1	MD-1	MD-7
Machining	Light-Duty	●	●	●
	General	●	●	●
	Heavy-Duty	●	●	
Material	Ferrous	●	●	
	Non-Ferrous	●	●	●
	Plastics		●	●
Application	Spray Cooling	●		
	Flooding	●		
	Micro-Dispensing		●	●
	Manual Application			
Fluid Type	Water Soluble	●		
	Synthetic Based	●		●
	Vegetable Based		●	



1235 HICKORY STREET
PEWAUKEE, WI 53072
800-558-7008 • 262-691-9336

WWW.TRICOCORP.COM

1149 BELLAMY ROAD N #23
TORONTO, ON M1H 1H7
416-439-9425 • 416-439-9472 (FAX)