

2015 USER GUIDE

RAM TRUCKS

1500/2500/3500



GUTS · GLORY



RAM



If you are the first registered retail owner of your vehicle, you may obtain a complimentary printed copy of the Owner's Manual, Navigation/Uconnect® Manuals or Warranty Booklet by calling 1-866-726-4636 (U.S.) or 1-800-387-1143 (Canada) or by contacting your dealer.

IMPORTANT

This User Guide is intended to familiarize you with the important features of your vehicle. The DVD enclosed contains your Owner's Manual, Navigation/Uconnect® Manuals, Warranty Booklets, Tire Warranty and Roadside Assistance (new vehicles purchased in the U.S.) or Roadside Assistance (new vehicles purchased in Canada) in electronic format. We hope you find it useful. Replacement DVD kits may be purchased by visiting www.techauthority.com.
Copyright 2014 Chrysler Group LLC.

The driver's primary responsibility is the safe operation of the vehicle. Driving while distracted can result in loss of vehicle control, resulting in a collision and personal injury. Chrysler Group LLC strongly recommends that the driver use extreme caution when using any device or feature that may take their attention off the road. Use of any electrical devices, such as cellular telephones, computers, portable radios, vehicle navigation or other devices, by the driver while the vehicle is moving is dangerous and could lead to a serious collision. Texting while driving is also dangerous and should never be done while the vehicle is moving. If you find yourself unable to devote your full attention to vehicle operation, pull off the road to a safe location and stop your vehicle. Some states or provinces prohibit the use of cellular telephones or texting while driving. It is always the driver's responsibility to comply with all local laws.

TABLE OF CONTENTS

INTRODUCTION/WELCOME

WELCOME FROM CHRYSLER GROUP LLC	3
---------------------------------	---

CONTROLS AT A GLANCE

DRIVER COCKPIT	6
INSTRUMENT CLUSTER	8

GETTING STARTED

KEY FOB	10
KEYLESS ENTER-N-GO™	13
REMOTE START	15
VEHICLE SECURITY ALARM	15
SEAT BELT SYSTEMS	16
SUPPLEMENTAL RESTRAINT SYSTEM (SRS) — AIR BAGS	17
CHILD RESTRAINTS	20
HEAD RESTRAINTS	28
FRONT SEATS	29
HEATED/VENTILATED SEATS	31
HEATED STEERING WHEEL	33
TILT STEERING COLUMN	34

OPERATING YOUR VEHICLE

ENGINE BREAK-IN RECOMMENDATIONS	36
TURN SIGNALS/WIPER/WASHER/HIGH BEAMS LEVER	37
HEADLIGHT SWITCH	38
ELECTRONIC SPEED CONTROL	39
EIGHT-SPEED AUTOMATIC TRANSMISSION — IF EQUIPPED	41
ELECTRONIC RANGE SELECT (ERS) OPERATION	42
1500 AIR SUSPENSION SYSTEM	44
2500-3500 AIR SUSPENSION SYSTEM	47
MANUAL CLIMATE CONTROLS WITHOUT TOUCHSCREEN	49
MANUAL CLIMATE CONTROLS WITH TOUCHSCREEN	50
AUTOMATIC CLIMATE CONTROLS WITH TOUCHSCREEN	52
PARKSENSE® FRONT AND REAR PARK ASSIST	54
PARKVIEW® REAR BACK-UP CAMERA	55
POWER SLIDING REAR WINDOW	55
POWER SUNROOF	56
WIND BUFFETING	57

ELECTRONICS

YOUR VEHICLE'S SOUND SYSTEM	58
IDENTIFYING YOUR RADIO	60
Uconnect® ACCESS	61
Uconnect® 3.0	79
Uconnect® 5.0	82
Uconnect® 8.4A	95

Uconnect® 8.4AN	126
STEERING WHEEL AUDIO CONTROLS	147
ELECTRONIC VEHICLE INFORMATION CENTER (EVIC) OR DRIVER INFORMATION DISPLAY (DID)	148
PROGRAMMABLE FEATURES	149
UNIVERSAL GARAGE DOOR OPENER (HomeLink®)	152
POWER INVERTER	155
POWER OUTLETS	155

OFF-ROAD CAPABILITIES

ELECTRONICALLY SHIFTED FOUR WHEEL DRIVE OPERATION	158
---	-----

UTILITY

TONNEAU COVER	161
EASY-OFF TAILGATE	161
PICKUP BOX	162
RAMBOX®	164
TOWING & PAYLOAD	168
TOW/HAUL MODE	168
INTEGRATED TRAILER BRAKE MODULE	169
RECREATIONAL TOWING (BEHIND MOTORHOME, ETC.)	170

1500 3.0L DIESEL

DIESEL ENGINE BREAK-IN RECOMMENDATIONS	176
DIESEL ENGINE STARTING PROCEDURES	176
DIESEL FUEL FILTER/WATER SEPARATOR	178
EXHAUST REGENERATION	179
COOL-DOWN IDLE CHART	180
ADDING FUEL — DIESEL ENGINE ONLY	181
DIESEL EXHAUST FLUID	182

6.7L CUMMINS® DIESEL

DIESEL ENGINE BREAK-IN RECOMMENDATIONS	186
DIESEL ENGINE STARTING PROCEDURES	186
DIESEL EXHAUST BRAKE (ENGINE BRAKING)	188
IDLE-UP FEATURE (AUTOMATIC TRANSMISSION ONLY)	189
ENGINE MOUNTED FUEL FILTER/WATER SEPARATOR	190
UNDERBODY MOUNTED FUEL FILTER/WATER SEPARATOR	191
EXHAUST REGENERATION	192
COOL-DOWN IDLE CHART	194
ADDING FUEL — DIESEL ENGINE ONLY	194
DIESEL EXHAUST FLUID	195

TABLE OF CONTENTS

WHAT TO DO IN EMERGENCIES

ROADSIDE ASSISTANCE	201
INSTRUMENT CLUSTER WARNING LIGHTS	201
INSTRUMENT CLUSTER INDICATOR LIGHTS	207
IF YOUR ENGINE OVERHEATS	208
JACKING AND TIRE CHANGING	209
JUMP-STARTING PROCEDURES	222
EMERGENCY TOW HOOKS	225
SHIFT LEVER OVERRIDE	225
MANUAL PARK RELEASE — EIGHT SPEED TRANSMISSION	226
TOWING A DISABLED VEHICLE	228
FREEING A STUCK VEHICLE	229
EVENT DATA RECORDER (EDR)	230

MAINTAINING YOUR VEHICLE

OPENING THE HOOD	231
ENGINE COMPARTMENT	232
GAS FLUID CAPACITIES	244
GAS FLUIDS, LUBRICANTS AND GENUINE PARTS	245
1500 3.0 DIESEL FLUID CAPACITIES	247
1500 3.0 DIESEL FLUIDS, LUBRICANTS AND GENUINE PARTS	247
6.7L CUMMINS® DIESEL FLUID CAPACITIES	249
6.7L CUMMINS® DIESEL FLUIDS, LUBRICANTS AND GENUINE PARTS	250

MAINTENANCE PROCEDURES	252
MAINTENANCE SCHEDULE — GASOLINE ENGINE	252
MAINTENANCE SCHEDULE — 1500 3.0L DIESEL ENGINE	257
MAINTENANCE SCHEDULE — 6.7L CUMMINS® DIESEL ENGINE	262
FUSES	267
TIRE PRESSURES	271
SPARE TIRES — IF EQUIPPED	271
WHEEL AND WHEEL TRIM CARE	273
REPLACEMENT BULBS	274

CUSTOMER ASSISTANCE

CHRYSLER GROUP LLC CUSTOMER CENTER	275
CHRYSLER CANADA INC. CUSTOMER CENTER	275
ASSISTANCE FOR THE HEARING IMPAIRED	275
PUBLICATIONS ORDERING	275
REPORTING SAFETY DEFECTS IN THE UNITED STATES	276

MOPAR® ACCESSORIES

AUTHENTIC ACCESSORIES BY MOPAR®	277
---	-----

FAQ's

FREQUENTLY ASKED QUESTIONS	278
--------------------------------------	-----

INDEX	280
-----------------	-----

INTRODUCTION/WELCOME

WELCOME FROM CHRYSLER GROUP LLC

Congratulations on selecting your new Chrysler Group LLC vehicle. Be assured that it represents precision workmanship, distinctive styling, and high quality - all essentials that are traditional to our vehicles.

Your new Chrysler Group LLC vehicle has characteristics to enhance the driver's control under some driving conditions. These are to assist the driver and are never a substitute for attentive driving. They can never take the driver's place. Always drive carefully.

Your new vehicle has many features for the comfort and convenience of you and your passengers. Some of these should not be used when driving because they take your eyes from the road or your attention from driving. Never text while driving or take your eyes more than momentarily off the road.

This guide illustrates and describes the operation of features and equipment that are either standard or optional on this vehicle. This guide may also include a description of features and equipment that are no longer available or were not ordered on this vehicle. Please disregard any features and equipment described in this guide that are not available on this vehicle. Chrysler Group LLC reserves the right to make changes in design and specifications and/or make additions to or improvements to its products without imposing any obligation upon itself to install them on products previously manufactured.

This User Guide has been prepared to help you quickly become acquainted with the important features of your vehicle. It contains most things you will need to operate and maintain the vehicle, including emergency information.

The DVD includes a computer application containing detailed owner's information which can be viewed on a personal computer or MAC computer. The multimedia DVD also includes videos which can be played on any standard DVD player (including the Uconnect® Touchscreen Radios if equipped with DVD player capabilities). Additional DVD operational information is located on the back of the DVD sleeve.

For complete owner information, refer to your Owner's Manual on the DVD in the owner's kit provided at the time of new vehicle purchase. For your convenience, the information contained on the DVD may also be printed and saved for future reference.

Chrysler Group LLC is committed to protecting our environment and natural resources. By converting from paper to electronic delivery for the majority of the user information for your vehicle, together we greatly reduce the demand for tree-based products and lessen the stress on our environment.

INTRODUCTION/WELCOME

VEHICLES SOLD IN CANADA

With respect to any vehicles sold in Canada, the name Chrysler Group LLC shall be deemed to be deleted and the name Chrysler Canada Inc. used in substitution (excluding legal lines).

WARNING!

- Pedals that cannot move freely can cause loss of vehicle control and increase the risk of serious personal injury.
- Always make sure that objects cannot fall into the driver foot well while the vehicle is moving. Objects can become trapped under the brake pedal and accelerator pedal causing a loss of vehicle control.
- Failure to properly follow floor mat installation or mounting can cause interference with the brake pedal and accelerator pedal operation causing loss of control of the vehicle.
- Never leave children alone in a vehicle, or with access to an unlocked vehicle. Allowing children to be in a vehicle unattended is dangerous for a number of reasons. A child or others could be seriously or fatally injured. Children should be warned not to touch the parking brake, brake pedal or the shift lever/transmission gear selector.
- Do not leave the key fob in or near the vehicle, or in a location accessible to children, and do not leave the ignition of a vehicle equipped with Keyless Enter-N-Go in the ACC or ON/RUN mode. A child could operate power windows, other controls, or move the vehicle.
- Never use the "PARK" position as a substitute for the parking brake. Always apply the parking brake fully when parked to guard against vehicle movement and possible injury or damage.
- Refer to your Owner's Manual on the DVD for further details.

USE OF AFTERMARKET PRODUCTS (ELECTRONICS)

The use of aftermarket devices including cell phones, MP3 players, GPS systems, or chargers may affect the performance of on-board wireless features including Keyless Enter-N-Go™ and Remote Start range. If you are experiencing difficulties with any of your wireless features, try disconnecting your aftermarket devices to see if the situation improves. If your symptoms persist, please see an authorized dealer.

CHRYSLER, DODGE, JEEP, RAM, SRT, MOPAR and Uconnect are registered trademarks of Chrysler Group LLC.

COPYRIGHT ©2014 CHRYSLER GROUP LLC



CONTROLS AT A GLANCE

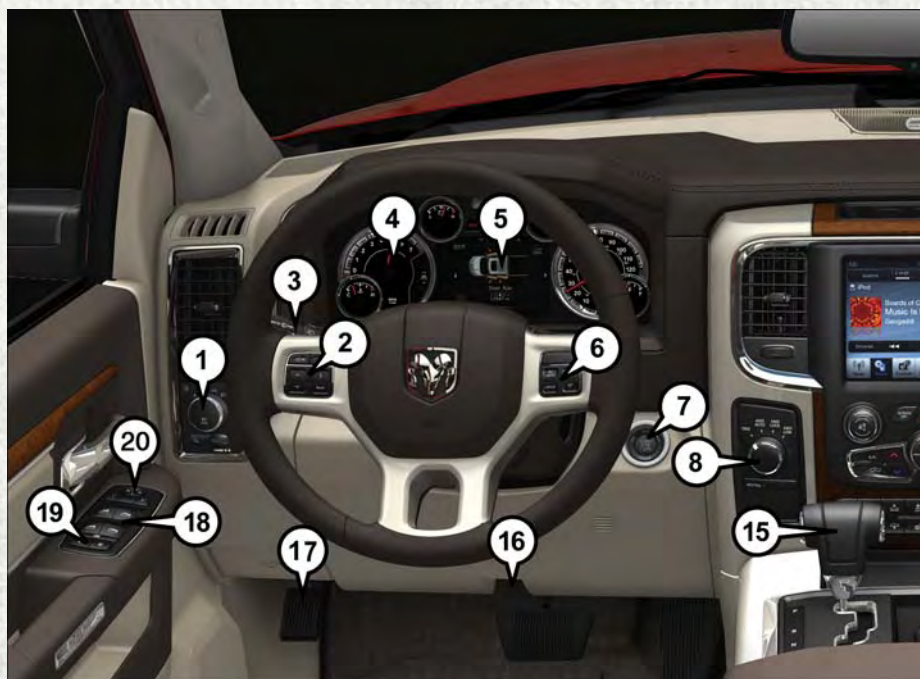

DRIVER COCKPIT

1. Headlight Switch pg. 38
2. Electronic Vehicle Information Center (EVIC) Controls Or Driver Information Display (DID) Controls pg. 148
3. Turn Signal/Wiper/Washer/High Beams Lever pg. 37
4. Instrument Cluster pg. 8
5. Electronic Vehicle Information Center (EVIC) or Driver Information Display (DID) pg. 148
6. Electronic Speed Control pg. 39
7. Engine Starting/Stopping pg. 14
8. Four Wheel Drive Operation pg. 158
9. Uconnect® Radio pg. 60
10. Climate Controls pg. 49

CONTROLS AT A GLANCE

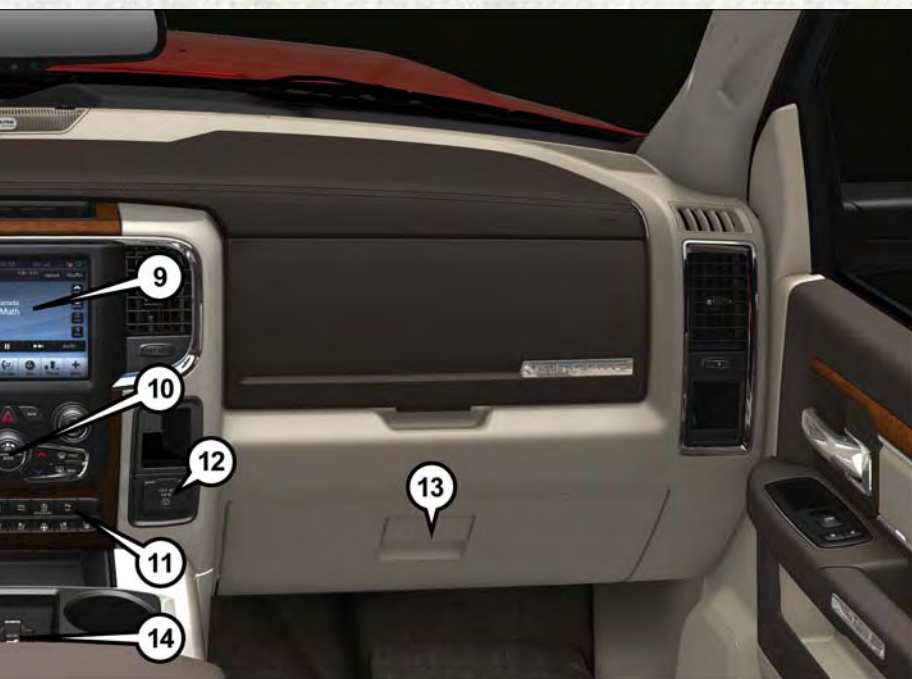

- 11. Switch Panel
- 12. Power Inverter Outlet pg. 155
- 13. Glove Compartment
- 14. Power Outlet
- 15. Shifter
- 16. Hood Release (below steering wheel at base of instrument panel) pg. 231
- 17. Parking Brake Release
- 18. Power Windows
- 19. Power Door Locks
- 20. Power Mirrors

CONTROLS AT A GLANCE



INSTRUMENT CLUSTER

1. Temperature Gauge
2. Tachometer
3. Voltmeter

(See page 201 for Instrument Cluster Warning Lights.)

CONTROLS AT A GLANCE



4. Electronic Vehicle Information Center (EVIC) Or Driver Information Display (DID)
5. Oil Pressure Gauge
6. Speedometer
7. Fuel Gauge

(See page 207 for Instrument Cluster Indicator Lights.)

GETTING STARTED

KEY FOB

This feature allows the driver to operate the ignition switch with the push of a button, as long as the Remote Keyless Entry (RKE) transmitter is in the passenger compartment.

The Keyless Ignition Node (KIN) has four operating positions, three of which are labeled and will illuminate when in position. The three positions are OFF, ACC, and ON/RUN. The fourth position is START, during start RUN will illuminate.



Key Fob

- 1 — Air Suspension
- 2 — Unlock
- 3 — Lock
- 4 — Remote Start
- 5 — Panic

NOTE:

In case the ignition switch does not change with the push of a button, the RKE transmitter (Key Fob) may have a low or dead battery. In this situation a back up method can be used to operate the ignition switch. Put the nose side (side opposite of the emergency key) of the Key Fob against the ENGINE START/STOP button and push to operate the ignition switch.

The Wireless Ignition Node (WIN) operates similar to an ignition switch. It has four operating positions, three with detents and one that is spring-loaded. The detent positions are OFF, ACC, and ON/RUN. The START position is a spring-loaded momentary contact position. When released from the START position, the switch automatically returns to the ON/RUN position.

Locking And Unlocking The Doors

Push and release the UNLOCK button on the RKE transmitter once to unlock the driver's door. Push and release the UNLOCK button twice within five seconds to unlock all doors and the tailgate and the RamBox® (if equipped). The turn signal lights will flash to acknowledge the unlock signal. The illuminated entry system will also turn on.

All doors can be programmed to unlock on the first push of the UNLOCK button. Refer to Programmable Features in this guide.

Panic Alarm

1. Push the PANIC button once to turn the panic alarm on.
2. Wait approximately three seconds and push the button a second time to turn the panic alarm off.



Key Fob

-
- 1 — Lock
 - 2 — Unlock
 - 3 — Remote Start
 - 4 — Emergency Key Release
 - 5 — Emergency Key

GETTING STARTED

RKE Air Suspension (Remote Lowering Of Vehicle) — If Equipped

- This vehicle is equipped with a feature that can lower the vehicle to a height which will improve ease of passenger entry/exit and cargo loading/unloading. The feature is accessed by pushing the air suspension lowering button twice on the key fob.
- When remote key fob lowering is requested the vehicle will send a series of chirps and flashes to alert the customer that the operation has begun and will continue these alerts until it successfully lowers.
- If the feature is unable to lower the vehicle due to certain conditions not being met, the horn will chirp twice and the vehicle will not lower.

Emergency Key

Should the battery in the vehicle or the Key Fob transmitter go dead, there is an emergency key located in the Key Fob that can be used for locking and unlocking the doors.

- To remove the emergency key, slide the button on the Key Fob with your thumb and then pull the key out with your other hand.

WARNING!

- Never leave children alone in a vehicle, or with access to an unlocked vehicle. Allowing children to be in a vehicle unattended is dangerous for a number of reasons. A child or others could be severely injured or killed. Children should be warned not to touch the parking brake, brake pedal, or the transmission gear selector. Do not leave the Key Fob in or near the vehicle, or in a location accessible to children, and do not leave the ignition of a vehicle equipped with Keyless Enter-N-Go™ in the ACC or ON/RUN mode. A child could start the vehicle, operate power windows, other controls, or move the vehicle.
- Do not leave children or animals inside parked vehicles in hot weather. Interior heat build-up may cause them to be severely injured or killed.

GETTING STARTED

KEYLESS ENTER-N-GO™

The Keyless Enter-N-Go™ system is an enhancement to the vehicle's Key Fob. This feature allows you to lock and unlock the vehicle's door(s) without having to push Key Fob lock or unlock buttons, as well as starting and stopping the vehicle with the push of a button.

To Unlock From The Driver Or Passenger Side:

With a valid Keyless Enter-N-Go™ Key Fob located outside the vehicle and within 5 ft (1.5m) of the driver or passenger side door handle, grab either front door handle to unlock the door automatically.



Grab The Door Handle To Unlock

To Lock The Vehicle's Doors:

With a valid Keyless Enter-N-Go™ Key Fob transmitter within 5 ft (1.5 m) of the driver or passenger front door handles, push door handle LOCK button to lock all doors.

Do NOT grab the door handle, when pushing the door handle lock button. This could unlock the door(s).



Push The Button To Lock

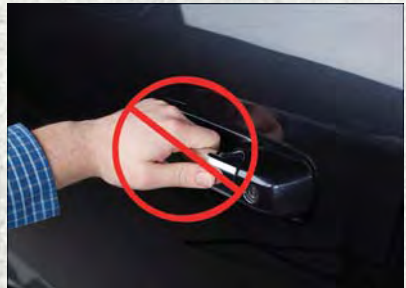

Do NOT Grab The Handle When Locking

GETTING STARTED

NOTE:

- After pushing the door handle LOCK button, you must wait two seconds before you can lock or unlock the doors, using either Passive Entry door handle. This is done to allow you to check if the vehicle is locked by pulling the door handle without the vehicle reacting and unlocking.
- The Passive Entry system will not operate if the RKE transmitter battery is dead.

The vehicle doors can also be locked by using the RKE transmitter lock button or the lock button located on the vehicles interior door panel.

Engine Starting/Stopping

Starting

With a valid Keyless Enter-N-Go™ Key Fob inside the vehicle:

1. Shift the transmission into PARK or NEUTRAL.
2. While pushing the brake pedal, push the ENGINE START/STOP button once. If the engine fails to start, the starter will disengage automatically after 10 seconds.
3. To stop the cranking of the engine prior to the engine starting, push the button again.



Start/Stop Button

NOTE:

In case the ignition switch does not change with the push of a button, the RKE transmitter (Key Fob) may have a low or dead battery. In this situation a back up method can be used to operate the ignition switch. Put the nose side of the Key Fob (side opposite of the Emergency Key) against the ENGINE START/STOP button and push to operate the ignition switch.



Stopping

1. Bring the vehicle to a complete stop.
2. Shift the transmission to PARK (P).
3. Push the ENGINE START/STOP button once. The ignition switch will return to the OFF position.

NOTE:

If the transmission is not in PARK and the vehicle is in motion, the ENGINE START/STOP button must be held for two seconds with the vehicle speed above 5 mph (8 km/h) before the engine will shut off.

REMOTE START

- Push REMOTE START button  on the Key Fob twice within five seconds. Pushing the REMOTE START  button a third time shuts the engine off.
- To drive the vehicle, push and release the UNLOCK button on the RKE transmitter to unlock the doors and disarm the Vehicle Security Alarm System (if equipped). Then cycle the ignition to the ON/RUN position.

With Remote Start, the engine will only run for 15 minutes (timeout) unless the ignition is cycled to the ON/RUN position.

The vehicle must be started with the Key Fob after two consecutive timeouts.

WARNING!

- Do not start or run an engine in a closed garage or confined area. Exhaust gas contains Carbon Monoxide (CO) which is odorless and colorless. Carbon Monoxide is poisonous and can cause you or others to be severely injured or killed when inhaled.
- Keep Key Fob transmitters away from children. Operation of the Remote Start System, windows, door locks or other controls could cause you and others to be severely injured or killed.

VEHICLE SECURITY ALARM

The Vehicle Security Alarm monitors the vehicle doors for unauthorized entry and the Keyless Enter-N-Go™ START/STOP button for unauthorized operation. While the Vehicle Security Alarm is armed, interior switches for door locks and decklid release are disabled. If something triggers the alarm, the Vehicle Security Alarm will provide the following audible and visible signals: the horn will pulse, the park lamps and/or turn signals will flash, and the Vehicle Security Light in the instrument cluster will flash.

To Arm:

- Lock the door using either the power door lock switch (one door must be open) or the LOCK button on the Remote Keyless Entry (RKE) transmitter (doors can be open or closed), and close all doors.

The Vehicle Security Light in the instrument cluster will flash for 16 seconds. This shows that the Vehicle Security Alarm is arming. During this period, if a door is opened, the ignition is cycled to ON/RUN, or the power door locks are unlocked in any manner, the Vehicle Security Alarm will automatically disarm.

NOTE:

- The Vehicle Security Alarm will not arm if you lock the doors with the manual door lock plungers.
- Once armed, the Vehicle Security Alarm disables the unlock switch on the driver door trim panel and passenger door trim panel.

GETTING STARTED

To Disarm The System:

- Push the Key Fob UNLOCK button or cycle the ignition to the ON/RUN position.

The Vehicle Security Alarm is designed to protect your vehicle; however, you can create conditions where the Vehicle Security Alarm will give you a false alarm. If one of the previously described arming sequences has occurred, the Vehicle Security Alarm will arm regardless of whether you are in the vehicle or not. If you remain in the vehicle and open a door, the alarm will sound. If this occurs, disarm the Vehicle Security Alarm.

If the Vehicle Security Alarm is armed and the battery becomes disconnected the Vehicle Security Alarm will remain armed when the battery is reconnected. The exterior lights will flash, and the horn will sound. If this occurs, disarm the Vehicle Security Alarm.

SEAT BELT SYSTEMS

Lap/Shoulder Belts

- All seating positions except the Quad Cab®, Mega Cab® and Crew Cab front center seating position have combination lap/shoulder belts.
- Be sure everyone in your vehicle is in a seat and using a seat belt properly.
- Position the lap belt so that it is snug and lies low across your hips, below your abdomen. To remove slack in the lap belt portion, pull up on the shoulder belt. To loosen the lap belt if it is too tight, tilt the latch plate and pull on the lap belt. A snug seat belt reduces the risk of sliding under the seat belt in a collision.
- Position the shoulder belt across the shoulder and chest with minimal, if any slack so that it is comfortable and not resting on your neck. The retractor will withdraw any slack in the shoulder belt.

Center Lap Belts

The center seating position for the Quad Cab®, Mega Cab® and Crew Cab front seat has a lap belt only. To buckle the lap belt, slide the latch plate into the buckle until you hear a "click." To lengthen the lap belt, tilt the latch plate and pull.

Seat Belt Pretensioner

- The front seat belt system is equipped with pretensioning devices that are designed to remove slack from the seat belt in the event of a collision.
- A deployed pretensioner or a deployed air bag must be replaced immediately.

WARNING!

- In a collision, you and your passengers can suffer much greater injuries if you are not properly buckled up. You can strike the interior of your vehicle or other passengers, or you can be thrown out of the vehicle. Always be sure you and others in your vehicle are buckled up properly.
- A shoulder belt placed behind you will not protect you from injury during a collision. You are more likely to hit your head in a collision if you do not wear your shoulder belt. The lap and shoulder belt are meant to be used together.
- A seat belt that is too loose will not protect you properly. In a sudden stop, you could move too far forward, increasing the possibility of injury. Wear your seat belt snugly.
- A frayed or torn seat belt could rip apart in a collision and leave you with no protection. Inspect the seat belt system periodically, checking for cuts, frays, or loose parts. Damaged parts must be replaced immediately. Do not disassemble or modify the system. Seat belt assemblies must be replaced after a collision.

SUPPLEMENTAL RESTRAINT SYSTEM (SRS) — AIR BAGS

Air Bag System Components

Your vehicle may be equipped with the following air bag system components:

- Occupant Restraint Controller (ORC)
- Air Bag Warning Light
- Steering Wheel and Column
- Instrument Panel
- Knee Impact Bolsters
- Advanced Front Air Bags
- Supplemental Side Air Bags
- Front and Side Impact Sensors (if equipped)
- Seat Belt Pretensioners
- Seat Belt Buckle Switch

GETTING STARTED

Advanced Front Air Bags

- This vehicle has Advanced Front Air Bags for both the driver and front passenger as a supplement to the seat belt restraint systems. The Advanced Front Air Bags will not deploy in every type of collision.
- Advanced Front Air Bags are designed to provide additional protection by supplementing the seat belts. Advanced Front Air Bags are not expected to reduce the risk of injury in rear, side, or rollover collisions.
- The Advanced Front Air Bags will not deploy in all frontal collisions, including some that may produce substantial vehicle damage — for example, some pole collisions, truck underrides, and angle offset collisions.
- On the other hand, depending on the type and location of impact, Advanced Front Air Bags may deploy in crashes with little vehicle front-end damage but that produce a severe initial deceleration.
- Because air bag sensors measure vehicle deceleration over time, vehicle speed and damage by themselves are not good indicators of whether or not an air bag should have deployed.
- Seat belts are necessary for your protection in all collisions, and also are needed to help keep you in position, away from an inflating air bag.
- The air bags must be ready to inflate for your protection in a collision. The Occupant Restraint Controller (ORC) monitors the internal circuits and interconnecting wiring associated with air bag system electrical components.
- The ORC turns on the Air Bag Warning Light in the instrument panel for approximately four to eight seconds for a self-check when the ignition switch is first turned to the ON/RUN position. After the self-check, the Air Bag Warning Light will turn off. If the ORC detects a malfunction in any part of the system, it turns on the Air Bag Warning Light, either momentarily or continuously. A single chime will sound to alert you if the light comes on again after initial startup.
- The ORC monitors the readiness of the electronic parts of the air bag system whenever the ignition switch is in the START or ON/RUN position. If the ignition switch is in the OFF position or in the ACC position, the air bag system is not on and the air bags will not inflate.
- If the Air Bag Warning Light in the instrument panel is not on during the four to eight seconds when the ignition switch is first turned to the ON/RUN position, stays on, or turns on while driving, have the vehicle serviced by an authorized service center immediately.

NOTE:

If the speedometer, tachometer, or any engine related gauges are not working, the Occupant Restraint Controller (ORC) may also be disabled. In this condition the air bags may not be ready to inflate for your protection. Have an authorized dealer service the air bag system immediately.

- After any collision, the vehicle should be taken to an authorized dealer immediately.
- Do not drive your vehicle after the air bags have deployed. If you are involved in another collision, the air bags will not be in place to protect you.

- If it is necessary to modify the air bag system for persons with disabilities, contact your authorized dealer.
- Refer to the Owner's Manual on the DVD for further details regarding the Supplemental Restraint System (SRS).

Supplemental Side Air Bags

- This vehicle is equipped with Supplemental Seat-Mounted Side Air Bags (SABs) located in the outboard side of the front seats. The SABs are marked with a SRS AIRBAG label sewn into the outboard side of the seats.
- This vehicle is equipped with Supplemental Side Air Bag Inflatable Curtains (SABICs) located above the side windows. The trim covering the SABICs is labeled SRS AIRBAG. The SABICs may help reduce the risk of partial or complete ejection of vehicle occupants through side windows in certain side impact events.
- The SABICs and SABs ("Side Air Bags") are designed to activate in certain side impacts and certain rollover events. The Occupant Restraint Controller ("ORC") determines whether the deployment of the Side Air Bags in a particular side impact or rollover event is appropriate, based on the severity and type of collision. Vehicle damage by itself is not a good indicator of whether or not Side Air Bags should have deployed.

WARNING!

- Side Air Bags need room to inflate. Do not lean against the door or window. Sit upright in the center of the seat.
- Being too close to the Side Air Bags during deployment could cause you to be severely injured or killed.
- Relying on the Side Air Bags alone could lead to more severe injuries in a collision. The Side Air Bags work with your seat belt to restrain you properly. In some collisions, Side Air Bags won't deploy at all. Always wear your seat belt even though you have Side Air Bags.
- This vehicle is equipped with left and right Supplemental Side Air Bag Inflatable Curtains (SABICs). Do not stack luggage or other cargo up high enough to block the deployment of the SABICs. The trim covering above the side windows where the SABIC and its deployment path are located should remain free from any obstructions.
- This vehicle is equipped with SABICs. In order for the SABICs to work as intended, do not install any accessory items in your vehicle which could alter the roof. Do not add an aftermarket sunroof to your vehicle. Do not add roof racks that require permanent attachments (bolts or screws) for installation on the vehicle roof. Do not drill into the roof of the vehicle for any reason.
- Do not use accessory seat covers or place objects between you and the Side Air Bags; the performance could be adversely affected and/or objects could be pushed into you, causing serious injury.

GETTING STARTED

CHILD RESTRAINTS

Children 12 years or younger should ride properly buckled up in a rear seat, if available. According to crash statistics, children are safer when properly restrained in the rear seats rather than in the front.

Every state in the United States and all Canadian provinces require that small children ride in proper restraint systems. This is the law, and you can be prosecuted for ignoring it.

NOTE:

- For additional information, refer to www.Seatcheck.org or call 1-866-SEATCHECK.
- Canadian residents should refer to Transport Canada's website for additional information: <http://www.tc.gc.ca/eng/motorvehiclesafety/safedrivers-childsafety-index-53.htm>

LATCH — Lower Anchors And Tethers For Children (Crew/Quad Cab Full Bench)

- Your vehicle is equipped with the child restraint anchorage system called LATCH, which stands for Lower Anchors and Tethers for CHildren.
- The rear outboard seating positions have lower anchors and top tether anchors. The rear center seating position has a top tether anchor only.

LATCH – Lower Anchors And Tethers For Children (Crew/Mega/Quad Cab Split Bench)

- Your vehicle is equipped with the child restraint anchorage system called LATCH, which stands for Lower Anchors and Tethers for CHildren.
- All rear seating positions have lower anchors and top tether anchors.

LATCH System Weight Limit

You may use the LATCH anchorage system until the combined weight of the child and the child restraint is 65 lbs (29.5 kg). Use the seat belt and tether anchor instead of the LATCH system once the combined weight is more than 65 lbs (29.5 kg).

Locating The LATCH Lower Anchorages

 The lower anchorages are round bars that are found at the rear of the seat cushion where it meets the seatback. They are just visible when you lean into the rear seat to install the child restraint. You will easily feel them if you run your finger along the gap between the seatback and seat cushion.



Lower Anchors

Locating The Tether Anchorages

 In addition, Regular Cab models have tether strap anchorages behind the front center and right seats. Quad Cab, Mega Cab and Crew Cab models have tether strap anchorages located behind each of the rear seats.

Center Seat LATCH (Crew/Standard/Quad Cab Full And Standard Bench)

Do not install a child restraint in the center position using the LATCH system. Use the seat belt and tether anchor to install a child seat in the center seating position.

Center Seat LATCH (Crew/Mega/Quad Cab Split Bench)

If a child restraint installed in the center position blocks the seat belt webbing or buckle for the outboard position, do not use that outboard position. If a child seat in the center position blocks the outboard LATCH anchors or seat belt, do not install a child seat in that outboard position.

GETTING STARTED

Installing The Child Restraint Using The LATCH Lower Anchors

NOTE:

Never “share” a LATCH anchorage with two or more child restraints.

1. Loosen the adjusters on the lower straps and on the tether strap of the child seat so that you can more easily attach the hooks or connectors to the vehicle anchorages.
2. Attach the lower hooks or connectors of the child restraint to the lower anchorages in the selected seating position.
3. If the child restraint has a tether strap, connect it to the top tether anchorage. See below for directions to attach a tether anchor.
4. Tighten all of the straps as you push the child restraint rearward and downward into the seat. Remove slack in the straps according to the child restraint manufacturer’s instructions.
5. Test that the child restraint is installed tightly by pulling back and forth on the child seat at the belt path. It should not move more than 1 inch (25.4 mm) in any direction.

Installing The Child Restraint Using The Vehicle Seat Belts (Standard Cab)

The seat belts in the passenger seating positions are equipped with a Switchable Automatic Locking Retractor (ALR) that is designed to keep the lap portion of the seat belt tight around the child restraint. Any seat belt system will loosen with time, so check the belt occasionally, and pull it tight if necessary.

Installing The Child Restraint Using The Vehicle Seat Belts (Crew/Mega/Quad Cab Full And Split Bench)

The seat belts in the outboard passenger seating positions are equipped with a Switchable Automatic Locking Retractor (ALR). The center seating positions are equipped with a cinching latch plate. Both types of seat belts are designed to keep the lap portion of the seat belt tight around the child restraint. Any seat belt system will loosen with time, so check the belt occasionally, and pull it tight if necessary.

Tether Anchorage Weight Limit

Always use the tether anchor when using the seat belt to install a forward facing child restraint, up to the recommended weight limit of the child restraint.

To Install A Child Seat Using An ALR:

1. Pull enough of the seat belt webbing from the retractor to pass it through the belt path of the child restraint. Do not twist the belt webbing in the belt path.
2. Slide the latch plate into the buckle until you hear a “click.”
3. Pull on the webbing to make the lap portion tight against the child seat.

4. To lock the seat belt, pull down on the shoulder part of the belt until you have pulled all the seat belt webbing out of the retractor. Then, allow the webbing to retract back into the retractor. As the webbing retracts, you will hear a clicking sound. This means the seat belt is now in the Automatic Locking mode.
5. Try to pull the webbing out of the retractor. If it is locked, you should not be able to pull out any webbing. If the retractor is not locked, repeat the last step.
6. Finally, pull up on any extra webbing to tighten the lap portion around the child restraint while you push the child restraint rearward and downward into the vehicle seat.
7. If the child restraint has a top tether strap and the seating position has a top tether anchorage, connect the tether strap to the anchorage and tighten the tether strap. See below for directions to attach a tether anchor.
8. Test that the child restraint is installed tightly by pulling back and forth on the child seat at the belt path. It should not move more than 1 inch (25.4 mm) in any direction.

To Install A Child Seat Using A Cinching Latch Plate:

1. Place the child seat in the center of the seating position.
2. Next, pull enough of the seat belt webbing from the retractor to pass it through the belt path of the child restraint. Do not twist the belt webbing in the belt path.
3. Slide the latch plate into the buckle until you hear a “click.”
4. Finally, pull up on any excess webbing to tighten the lap portion around the child restraint while you push the child restraint rearward and downward into the vehicle seat.
5. If the child restraint has a top tether strap and the seating position has a top tether anchorage, connect the tether strap to the anchorage and tighten the tether strap. See below for directions to attach a tether anchor.
6. Test that the child restraint is installed tightly by pulling back and forth on the child seat at the belt path. It should not move more than 1 inch (25.4 mm) in any direction.

Installing The Top Tether Strap (With Either Lower Anchors Or Vehicle Seat Belt):

When installing a forward-facing child restraint, always secure the top tether strap, up to the tether anchor weight limit, whether the child restraint is installed with the lower anchors or the vehicle seat belt.

GETTING STARTED

Tether Anchorage Installation

Regular and Mega Cab Trucks:

In the regular cab truck, the top tether anchorages are located behind the center and right passenger seats. In the mega cab truck, the top tether anchorages are located behind each rear seating position. There is a plastic cover over each anchorage. To attach the tether strap of the child restraint:

1. Place the child restraint on the seat and adjust the tether strap so that it will reach over the seat back, under the head restraint and to the tether anchor directly behind the seat.
2. Route the tether strap to provide the most direct path between the anchorage and the child seat. The tether strap should go between the head restraint posts underneath the head restraint. You may need to adjust the head restraint to the upward position to pass the tether strap underneath the head restraint and between its posts.
3. Lift the cover (if equipped) and attach the hook to the square opening in the sheet metal. Tighten the tether strap according to the child seat manufacturer's instructions.

Quad or Crew Cab Trucks:

The top tether anchorages in this vehicle are tether strap loops located between the rear glass and the back of the rear seat. There is a tether strap loop located behind each seating position. Follow the steps below to attach the tether strap of the child restraint.

Right or Left Outboard Seats:

1. Raise the head restraint and reach between the rear seat and rear glass to access the tether strap loop.



Head Restraint In Raised Position



Tether Strap Loop With Center Head Restraint In Raised Position

2. Place a child restraint on the seat and adjust the tether strap so that it will reach over the seat back, under the head restraint, through the tether strap loop behind the seat and over to the tether strap loop behind the center seat.

GETTING STARTED

3. Pass the tether strap hook under the head restraint behind the child seat, though the tether strap loop behind the seat and over to the center tether strap loop.

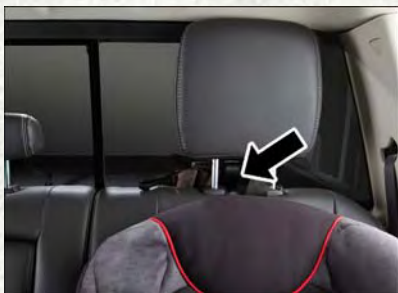

Tether Strap Through Outboard Tether Strap Loop

4. Attach the hook to the center tether strap loop (see diagram). Tighten the tether strap according to the child seat manufacturer's instructions.

NOTE:

If there are child seats in both of the outboard (left and right) seating positions, the tether strap hooks of both child seats should be connected to the center tether strap loop. This is the correct way to tether two outboard child seats.



Tether Strap Through Outboard Tether Strap Loop And Attached To Center Tether Strap Loop

GETTING STARTED

Center Seat:

1. Raise the head restraint and reach between the rear seat and rear glass to access the tether strap loop.
2. Place a child restraint on the seat and adjust the tether strap so that it will reach over the seat back, under the head restraint, through the tether strap loop behind the seat and over to the tether strap loop behind either the right or left outboard seat.



Tether Strap Loop With Head Restraint In Raised Position

3. Pass the tether strap hook under the head restraint behind the child seat, through the tether strap loop behind the seat and over to the right or left outboard tether strap loop.
4. Attach the hook to the outboard tether strap loop (see diagram). Tighten the tether strap according to the child seat manufacturer's instructions.



Tether Strap Through Center Tether Strap Loop



Tether Strap Through Center Tether Strap Loop And Attached To Outboard Tether Strap Loop

GETTING STARTED

Installing Three Child Restraints:

1. Place a child restraint on each outboard rear seat. Route the tether straps following the directions for right and left seating positions, above.
2. Attach both hooks to the center tether strap loop, but do not tighten the straps yet.
3. Place a child restraint on the center rear seat. Route the tether strap following the directions for the center seating position, above.
4. Attach the hook to the outboard tether strap loop.
5. Tighten the tether straps according to the child seat manufacturer's instructions, tightening the right and left tether straps before the center tether strap.



Left Outboard And Center Seating Position Shown

WARNING!

Securely lock the seat cushion into position before using the seat. Otherwise, the seat will not provide the proper stability for child seats and/or passengers. An improperly latched seat cushion could cause serious injury.

WARNING!

- In a collision, an unrestrained child, even a tiny baby, can become a projectile inside the vehicle. The force required to hold even an infant on your lap could become so great that you could not hold the child, no matter how strong you are. The child and others could be severely injured or killed. Any child riding in your vehicle should be in a proper restraint for the child's size.
- Rearward-facing child seats must never be used in the front seat of a vehicle with a front passenger air bag. An air bag deployment could cause severe injury or death to infants in this position.
- Only use a rearward-facing child restraint in a vehicle with a rear seat.
- Improper installation of a child restraint to the LATCH anchorages can lead to failure of an infant or child restraint. The child could be severely injured or killed. Follow the manufacturer's directions exactly when installing an infant or child restraint.
- An incorrectly anchored tether strap could lead to increased head motion and possible injury to the child. Use only the anchor positions directly behind the child seat to secure a child restraint top tether strap.
- If your vehicle is equipped with a split rear seat, make sure the tether strap does not slip into the opening between the seatbacks as you remove slack in the strap.

GETTING STARTED

HEAD RESTRAINTS

Head restraints are designed to reduce the risk of injury by restricting head movement in the event of a rear impact. Head restraints should be adjusted so that the top of the head restraint is located above the top of your ear.

WARNING!

The head restraints for all occupants must be properly installed and adjusted prior to operating the vehicle or occupying a seat. Head restraints should never be adjusted while the vehicle is in motion. Driving a vehicle with the head restraints improperly adjusted or removed could cause serious injury or death in the event of a collision.

Front Head Restraints

To raise the head restraint, pull upward on the head restraint. To lower the head restraint, press the adjustment button, located on the base of the head restraint, and push downward on the head restraint.

To remove the head restraint, raise it as far as it can go then press the release buttons at the base of each post while pulling the head restraint up. To reinstall the head restraint, put the head restraint posts into the holes while pressing the release buttons. Then adjust it to the appropriate height.

WARNING!

A loose head restraint thrown forward in a collision or hard stop could cause serious injury or death to occupants of the vehicle. Always securely stow removed head restraints in a location outside the occupant compartment.

WARNING!

ALL the head restraints MUST be reinstalled in the vehicle to properly protect the occupants. Follow the re-installation instructions above prior to operating the vehicle or occupying a seat.

Rear Head Restraints

The rear seats are equipped with adjustable head restraints. To raise the head restraint, pull upward on the head restraint. To lower the head restraint, press the adjustment button, located on the base of the head restraint, and push downward on the head restraint.

NOTE:

- The rear center head restraint (Crew Cab and Quad Cab) has only one adjustment position that is used to aid in the routing of a tether. Refer to “Occupant Restraints” in “Things to Know Before Starting Your Vehicle” in the Owner’s Manual on the DVD.
- The head restraints should only be removed by qualified technicians, for service purposes only. If either of the head restraints require removal, see your authorized dealer.

FRONT SEATS

Power Seats

The seat switch controls forward/backward and up/down. The recline switch controls the angle of the seatback.

- Push the switch forward or rearward and the seatback will move in either direction.

Power Lumbar

The lumbar controls are located on the outboard side of the seat cushion.

- The lumbar support can be increased by pressing the front of the switch and decreased by pressing the back of the switch.



Power Seat Switches

- 1 — Power Seat Switch
- 2 — Recline Switch
- 3 — Power Lumbar Switch

GETTING STARTED

Memory Seat

The memory seat feature allows you to save the driver's seat position (excluding lumbar position), driver's outside mirror position, adjustable brake and accelerator pedals, Automatic Temperature Control (ATC) temperature setting and radio station preset settings. The driver's memory buttons are located on the outboard side of the driver's seat cushion.

- Adjust all memory profile settings, press the middle button S (SET), then press 1 or 2 within five seconds.
- To program a Key Fob to the memory position, place the ignition switch in the LOCK position and remove the Key Fob, press and release the LOCK button on the Key Fob to be programmed within five seconds of pressing button 1 or 2.
- Press 1 or 2 to recall the saved positions, or press UNLOCK on the programmed Key Fob.

Refer to the Owner's Manual on the DVD for further details.



Memory Seat Button Location

Manual Seats

Forward/Rearward

Lift up on the adjusting bar located at the front of the seat near the floor and release it when the seat is at the desired position. Then, using body pressure, move forward and backward on the seat to be sure that the seat adjusters have latched.

Recliner

Lift the recliner lever located on the outboard side of the seat, lean back and release at the desired position.



Manual Seat Adjusting Bar/Recline Lever

- 1 — Recline Lever
2 — Adjusting Bar

CAUTION!

Do not place any article under a power seat or impede its ability to move as it may cause damage to the seat controls. Seat travel may become limited if movement is stopped by an obstruction in the seat's path.

WARNING!

- Adjusting a seat while the vehicle is moving is dangerous. The sudden movement of the seat could cause you to lose control. The seat belt might not be properly adjusted, and you could be severely injured or killed. Only adjust a seat while the vehicle is parked.
- Actuating the recliner handle will allow the seatback to swing forward. Do not stand or lean in front of the seatback while actuating the handle. The seatback may swing forward and strike you, causing injury. To avoid possible injury, place your hand on the seatback while actuating the recliner handle.
- Do not ride with the seatback reclined so that the seat belt is no longer resting against your chest. In a collision, you could slide under the seat belt and be severely injured or killed. Use the recliner only when the vehicle is parked.



HEATED/VENTILATED SEATS

Front Ventilated Seats

Located in the seat cushion are small fans that draw the air from the passenger compartment and pull air through fine perforations in the seat cover to help keep the driver and front passenger cooler in higher ambient temperatures. The fans operate at two speeds, HIGH and LOW.

The front ventilated seats control buttons  are located on the center instrument panel below the climate controls.

If your vehicle is equipped with a touchscreen, the front ventilated seats control buttons are located within the climate or controls screen of the touchscreen.

- Press the ventilated seat button  once to choose HIGH.
- Press the ventilated seat button  a second time to choose LOW.
- Press the ventilated seat button  a third time to turn the ventilated seat OFF.

GETTING STARTED

Vehicle Equipped With Remote Start

On models that are equipped with remote start, this feature can be programmed to come on during a remote start.



If your vehicle is equipped with a touchscreen, this feature can be programmed through the Uconnect® system. Refer to “Uconnect® Settings” in “Understanding Your Instrument Panel” in the Owner's Manual on the DVD.

If your vehicle is not equipped with a touchscreen, this feature can be programmed through the Electronic Vehicle Information Center (EVIC). Refer to “Electronic Vehicle Information Center (EVIC)” in “Understanding Your Instrument Panel” in the Owner's Manual on the DVD.

Front Heated Seats

The front heated seats control buttons  are located on the center instrument panel below the climate controls.

If your vehicle is equipped with a touchscreen, the front heated seats control buttons are located within the climate or controls screen of the touchscreen.

- Press the heated seat button  once to turn the High setting On.
- Press the heated seat button  a second time to turn the Low setting On.
- Press the heated seat button  a third time to turn the heating elements Off.

When the HI-level setting is selected, the heater will provide a boosted heat level during the first four minutes of operation. Then, the heat output will drop to the normal HI-level. If the HI-level setting is selected, the system will automatically switch to LO-level after a maximum of 60 minutes of continuous operation. At that time, the display will change from HI to LO, indicating the change. The LO-level setting will turn OFF automatically after a maximum of 45 minutes.

Vehicle Equipped With Remote Start



On models that are equipped with remote start, this feature can be programmed to come on during a remote start.

If your vehicle is equipped with a touchscreen, this feature can be programmed through the Uconnect® system. Refer to “Uconnect® Settings” in “Understanding Your Instrument Panel” in the Owner's Manual on the DVD.

If your vehicle is not equipped with a touchscreen, this feature can be programmed through the Electronic Vehicle Information Center (EVIC). Refer to “Electronic Vehicle Information Center (EVIC)” in “Understanding Your Instrument Panel” in the Owner's Manual on the DVD.

REAR HEATED SEATS

The rear heated seat switches are located on the rear of the center console.

- Press the heated seat button  once to turn the High setting On.
- Press the heated seat button  a second time to turn the Low setting On.
- Press the heated seat button  a third time to turn the heating elements Off.

When the HIGH-level setting is selected, the heater will provide a boosted heat level during the first four minutes of operation. Then, the heat output will drop to the normal HIGH-level. If the HIGH-level setting is selected, the system will automatically switch to LOW-level after a maximum of 60 minutes of continuous operation. At that time, the number of illuminated LEDs changes from two to one, indicating the change. The LOW-level setting will turn OFF automatically after a maximum of 45 minutes.

WARNING!



- Persons who are unable to feel pain to the skin because of advanced age, chronic illness, diabetes, spinal cord injury, medication, alcohol use, exhaustion or other physical conditions must exercise care when using the seat heater. It may cause burns even at low temperatures, especially if used for long periods of time.
- Do not place anything on the seat that insulates against heat, such as a blanket or cushion. This may cause the seat heater to overheat. Sitting in a seat that has been overheated could cause serious burns due to the increased surface temperature of the seat.

HEATED STEERING WHEEL

The steering wheel contains a heating element that heats the steering wheel to one temperature setting.

The heated steering wheel control button  is located on the center instrument panel below the climate controls.

If your vehicle is equipped with a touchscreen, the heated steering wheel control button is located within the climate or controls screen of the touchscreen.

- Press the heated steering wheel button  once to turn the heating element On.
- Press the heated steering wheel button  a second time to turn the heating element Off.

Once the heated steering wheel has been turned on, it will operate for approximately 30 to 80 minutes before automatically shutting off. The heated steering wheel can shut off early or may not turn on when the steering wheel is already warm.

GETTING STARTED

Vehicle Equipped With Remote Start

On models that are equipped with remote start, this feature can be programmed to come on during a remote start.

If your vehicle is equipped with a touchscreen, this feature can be programmed through the Uconnect® system. Refer to “Uconnect® Settings” in “Understanding Your Instrument Panel” in the Owner’s Manual on the DVD.

If your vehicle is not equipped with a touchscreen, this feature can be programmed through the Electronic Vehicle Information Center (EVIC). Refer to “Electronic Vehicle Information Center (EVIC)” in “Understanding Your Instrument Panel” in the Owner’s Manual on the DVD.

WARNING!

- Persons who are unable to feel pain to the skin because of advanced age, chronic illness, diabetes, spinal cord injury, medication, alcohol use, exhaustion, or other physical conditions must exercise care when using the steering wheel heater. It may cause burns even at low temperatures, especially if used for long periods.
- Do not place anything on the steering wheel that insulates against heat, such as a blanket or steering wheel covers of any type and material. This may cause the steering wheel heater to overheat.

TILT STEERING COLUMN

The tilt lever is located on the steering column below the turn signal lever.

- To tilt the column, simply pull the tilt lever rearward toward you and then move the steering wheel upward or downward as desired.
- Release the tilt lever to lock the steering wheel into position.



Tilt Lever Location

- 1 — Adjustable Pedal Switch
2 — Tilt Lever

ADJUSTABLE PEDALS

Press the switch located on the left side of the steering column forward to move the brake and accelerator pedals away from the driver and press the switch rearward to move the pedals closer to the driver.

NOTE:

The pedals cannot be adjusted when the vehicle is in REVERSE or when the Electronic Speed Control is set.

CAUTION!

Do not place any article under the adjustable pedals or impede its ability to move, as it may cause damage to the pedal controls. Pedal travel may become limited if movement is stopped by an obstruction in the adjustable pedal's path.

WARNING!

- Tilting the steering column while the vehicle is moving is dangerous. Without a stable steering column, you could lose control of the vehicle and have a collision. Adjust the column only while the vehicle is stopped. Be sure it is locked before driving.
- Do not adjust the pedals while the vehicle is moving. You could lose control and have a collision. Always adjust the pedals while the vehicle is parked.

OPERATING YOUR VEHICLE

ENGINE BREAK-IN RECOMMENDATIONS

A long break-in period is not required for the engine and drivetrain (transmission and axle) in your vehicle.

Drive moderately during the first 300 miles (500 km). After the initial 60 miles (100 km), speeds up to 50 or 55 mph (80 or 90 km/h) are desirable.

While cruising, brief full-throttle acceleration within the limits of local traffic laws contributes to a good break-in. Wide-open throttle acceleration in low gear can be detrimental and should be avoided.

The engine oil installed in the engine at the factory is a high-quality energy conserving type lubricant. Oil changes should be consistent with anticipated climate conditions under which vehicle operations will occur. For the recommended viscosity and quality grades, refer to "Maintaining Your Vehicle."

NOTE:

A new engine may consume some oil during its first few thousand miles (kilometers) of operation. This should be considered a normal part of the break-in and not interpreted as an indication of an engine problem or malfunction.

CAUTION!

Never use Non-Detergent Oil or Straight Mineral Oil in the engine or damage may result.

DIESEL ENGINE BREAK-IN RECOMMENDATIONS

- For 3.0L diesel engine break-in recommendations, refer to Diesel Engine Break-In Recommendations on pg. 176
- For 6.7L Cummins diesel engine break-in recommendations, refer to Diesel Engine Break-In Recommendations on pg. 186

OPERATING YOUR VEHICLE

TURN SIGNALS/WIPER/WASHER/HIGH BEAMS LEVER



Turn Signal/Wiper/Washer/High Beam Lever

Turn Signals/Lane Change Assist

Tap the lever up or down once and the turn signal (right or left) will flash three times and automatically turn off.

Wipers

Intermittent, Low And High Operation

- Rotate the end of the lever to the first detent position for one of five intermittent settings, the second detent for low wiper operation and the third detent for high wiper operation.

Washer Operation

- Push the end of the lever inward to the second detent and hold for as long as spray is desired.

Mist Feature

- When a single wipe to clear off road mist or spray from a passing vehicle is needed, push the washer knob, located on the end of the multifunction lever, inward to the first detent and release. The wipers will cycle one time and automatically shut off.

High Beams

- Push the lever away from you to activate the high beams.

A high beam symbol will illuminate in the cluster to indicate the high beams are on.



NOTE:

For safe driving, turn off the high beams when oncoming traffic is present to prevent headlight glare and as a courtesy to other motorists.

OPERATING YOUR VEHICLE

HEADLIGHT SWITCH

Automatic Headlights/Parking Lights/Headlights

- Rotate the headlight switch, located on the instrument panel to the left of the steering wheel, to the first detent  for parking lights and to the second detent for headlights .
- With the parking lights or low beam headlights on, push the headlight switch once for fog lights.
- Rotate the headlight switch to AUTO for Automatic headlights.
- When set to AUTO, the system automatically turns the headlights on or off based on ambient light levels.

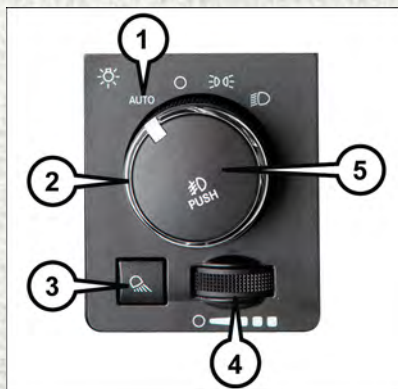

Headlight Switch

- 1 — Auto
- 2 — Rotate Headlight Switch
- 3 — Push Cargo Light
- 4 — Rotate Dimmer
- 5 — Push Fog Light

Automatic High Beams

The Automatic High Beams system provides increased forward lighting at night by automating high beam control through the use of a digital camera mounted above the inside rearview mirror. This camera detects vehicle specific light and automatically switches from high beams to low beams until the approaching vehicle is out of view. This feature is programmable through the Uconnect® system. Refer to “Uconnect® Settings” in “Understanding Your Instrument Panel” in the Owner’s Manual on the DVD for further details.

Instrument Panel Dimmer

- Rotate the dimmer control to the extreme left position to fully dim the instrument panel lights and prevent the interior lights from illuminating when a door is opened.
- Rotate the dimmer control right to increase the brightness of the instrument panel when the parking lights or headlights are on.
- Rotate the dimmer control right to the next detent position to fully brighten the odometer and radio when the parking lights or headlights are on.
- Rotate the dimmer control right to the last detent position to turn on the interior lighting.
- If your vehicle is equipped with a touchscreen, the dimming is programmable through the Uconnect® system. Refer to “Uconnect® Settings” in “Understanding Your Instrument Panel” in the Owner’s Manual on the DVD for further details.

OPERATING YOUR VEHICLE

Cargo Light

The cargo light is strategically placed lighting that helps illuminate the bed area of the truck. A cargo light symbol will illuminate in the cluster to indicate the light is on.

- Push the button to turn ON/OFF the cargo lighting.

ELECTRONIC SPEED CONTROL

The Electronic Speed Control switches are located on the steering wheel.



Electronic Speed Control Switches

- 1 — Push CANCEL
- 2 — Push ON/OFF
- 3 — Push Resume/Accel
- 4 — Push Set/Decel

Cruise ON/OFF

- Push the ON/OFF switch to activate the Speed Control.

The cruise symbol  will appear on the instrument cluster to indicate the Speed Control is on.

- Push the ON/OFF switch a second time to turn the system off.

Set

- With the Speed Control on, push and release the SET/DECEL switch to set a desired speed.

OPERATING YOUR VEHICLE

Accel/Decel

To Increase Speed

- When the Electronic Speed Control is set, you can increase speed by pushing the RES + button.

The drivers preferred units can be selected through the instrument panel settings if equipped. Refer to “ Understanding Your Instrument Panel” for more information. The speed increment shown is dependant on the chosen speed unit of U.S. (mph) or Metric (km/h):

U.S. Speed (mph)

- Pushing the RES + button once will result in a 1 mph increase in set speed. Each subsequent tap of the button results in an increase of 1 mph.
- If the button is continually pushed, the set speed will continue to increase until the button is released, then the new set speed will be established.

Metric Speed (km/h)

- Pushing the RES + button once will result in a 1 km/h increase in set speed. Each subsequent tap of the button results in an increase of 1 km/h.
- If the button is continually pushed, the set speed will continue to increase until the button is released, then the new set speed will be established.

To Decrease Speed

- When the Electronic Speed Control is set, you can decrease speed by pushing the SET - button.

The drivers preferred units can be selected through the instrument panel settings if equipped. Refer to “ Understanding Your Instrument Panel” for more information. The speed decrement shown is dependant on the chosen speed unit of U.S. (mph) or Metric (km/h):

U.S. Speed (mph)

- Pushing the SET - button once will result in a 1 mph decrease in set speed. Each subsequent tap of the button results in a decrease of 1 mph.
- If the button is continually pushed, the set speed will continue to decrease until the button is released, then the new set speed will be established.

Metric Speed (km/h)

- Pushing the SET - button once will result in a 1 km/h decrease in set speed. Each subsequent tap of the button results in a decrease of 1 km/h.
- If the button is continually pushed, the set speed will continue to decrease until the button is released, then the new set speed will be established.

OPERATING YOUR VEHICLE

Resume

- To resume a previously selected set speed in memory, push the RESUME/ACCEL switch and release.

Cancel

- Push the CANCEL switch or apply the brakes to cancel the set speed and maintain the set speed memory.
- Push the ON/OFF switch to turn the system off and erase the set speed memory.

WARNING!

- Leaving the Electronic Speed Control system on when not in use is dangerous. You could accidentally set the system or cause it to go faster than you want. You could lose control and have a collision. Always leave the Electronic Speed Control system off when you are not using it.
- Electronic Speed Control can be dangerous where the system cannot maintain a constant speed. Your vehicle could go too fast for the conditions, and you could lose control. A collision could be the result. Do not use Electronic Speed Control in heavy traffic or on roads that are winding, icy, snow-covered or slippery.

EIGHT-SPEED AUTOMATIC TRANSMISSION — IF EQUIPPED

- Your vehicle may be equipped with a fuel efficient eight-speed transmission. The electronic transmission gear selector is located on the instrument panel. The transmission gear (PRND) is displayed both above the shifter control and in the Electronic Vehicle Information Center (EVIC)/Driver Information Display (DID).
- To select a gear range, simply rotate the shifter control.

NOTE:

You must press the brake pedal to shift the transmission out of PARK or from NEUTRAL into DRIVE or REVERSE.

- To shift past multiple gear ranges at once (such as Park to Drive), simply rotate the switch to the appropriate detent.
- Select the DRIVE range for normal driving.



Rotary Gear Selector

OPERATING YOUR VEHICLE

ELECTRONIC RANGE SELECT (ERS) OPERATION

- Electronic Range Select (ERS) allows you to limit the highest available transmission gear, and can be activated during any driving condition. When towing a trailer or operating the vehicle in off-road conditions, using ERS shift control will help you maximize both performance and engine braking.
- Move the console shift lever left (-) or right (+), or toggle the switch on the column shift lever down (-) or up (+) to select the desired top gear.



ERS Control Position



ERS Control On The Shift Lever

- For maximum deceleration (engine braking) move the console shift lever left (-) and hold, or toggle the switch on the column shift lever down (-) and hold. Your vehicle will automatically select the lowest safe gear for optimal engine braking.
- To disable ERS, push and hold the console shift lever to the right (+) or push and hold the column shift lever switch up (+) until "D" is displayed in the odometer.
- Switching between ERS and DRIVE mode can be done at any vehicle speed.
- Refer to your Owner's Manual on the DVD for further details.

OPERATING YOUR VEHICLE

ELECTRONIC RANGE SELECT (ERS) OPERATION — EIGHT-SPEED TRANSMISSION

- The Electronic Range Select (ERS) shift control allows the driver to limit the highest available gear when the transmission shifter switch is in the DRIVE position
- You can switch between DRIVE and ERS mode at any vehicle speed.
- Tapping the ERS (-) switch (on the steering wheel) will activate ERS mode.
- Once in ERS mode, tapping the ERS (-) or (+) switch will change the top available gear.
- To exit ERS mode, simply press and hold the ERS (+) switch until “D” is once again displayed in the transmission gear position indicator in the instrument cluster.



ERS Control

OPERATING YOUR VEHICLE

1500 AIR SUSPENSION SYSTEM

The air suspension system provides full time load leveling capability along with the benefit of being able to adjust vehicle height by the push of a button.

Automatic height changes will occur based on vehicle speed and the current vehicle height. The indicator lamps and EVIC/DID messages will operate the same for automatic changes and user requested changes.

Description

Normal Ride Height (NRH) - This is the standard position of the suspension and is meant for normal driving.

Off-Road 1 (OR1) (Raises the vehicle approximately 1 in (26 mm)) - This position should be the primary position for all off-road driving until Off Road 2 (OR2) is needed. A smoother and more comfortable ride will result. To enter OR1, press the “Up” button once from the NRH position while the vehicle speed is below 35 mph (56 km/h). When in the OR1 position, if the vehicle speed remains between 40 mph (64 km/h) and 50 mph (80 km/h) for greater than 20 seconds or if the vehicle speed exceeds 50 mph (80 km/h), the vehicle will be automatically lowered to NRH. Off-Road 1 may not be available due to vehicle payload, an EVIC/DID message will be displayed when this occurs. Refer to “Electronic Vehicle Information Center (EVIC)/Driver Information Display (DID)” in “Understanding Your Instrument Panel” in the Owner’s Manual on the DVD for further information.

Off-Road 2 (OR2) (Raises the vehicle approximately 2 in (51 mm)) - This position is intended for off-roading use only where maximum ground clearance is required. To enter OR2, press the “Up” button twice from the NRH position or once from the OR1 position while vehicle speed is below 20 mph (32 km/h). While in OR2, if the vehicle speed exceeds 25 mph (40 km/h) the vehicle height will be automatically lowered to OR1. Off-Road 2 may not be available due to vehicle payload, an EVIC/DID message will be displayed when this occurs. Refer to “Electronic Vehicle Information Center (EVIC)/Driver Information Display (DID)” in “Understanding Your Instrument Panel” in the Owner’s Manual on the DVD for further information.



1500 Air Suspension Controls

- 1 — Off-Road 1 Indicator
- 2 — Off-Road 2 Indicator
- 3 — Up Button
- 4 — Down Button
- 5 — Entry/Exit Mode Indicator
- 6 — Normal Ride Height Indicator

OPERATING YOUR VEHICLE

Aero Mode (Lowers the vehicle approximately .6 in (15 mm) – 1500 Models Only - This position provides improved aerodynamics by lowering the vehicle. The vehicle will automatically enter Aero Mode when the vehicle speed remains between 62 mph (100 km/h) and 66 mph (106 km/h) for greater than 20 seconds or if the vehicle speed exceeds 66 mph (106 km/h). The vehicle will return to NRH from Aero Mode if the vehicle speed remains between 30 mph (48 km/h) and 35 mph (56 km/h) for greater than 20 seconds or if the vehicle speed falls below 30 mph (48 km/h).

NOTE:

Automatic Aero Mode may be disabled through vehicle settings in the Electronic Vehicle Information Center (EVIC)/Driver Information Display (DID) when equipped with Uconnect 3.0, or your Uconnect® Radio when equipped with UConnect® 5.0, 8.4A, or 8.4AN.

Entry/Exit Mode (Lowers the vehicle approximately 2 in (51 mm) - This position lowers the vehicle for easier passenger entry and exit as well as lowering the rear of the vehicle for easier loading and unloading of cargo. To enter Entry/Exit Mode, press the “Down” button once from the NHR while the vehicle speed is below 33 mph (53 km/h). Once the vehicle speed goes below 15 mph (24 km/h) the vehicle height will begin to lower. If the vehicle speed remains between 15 mph (24 km/h) and 25 mph (40 km/h) for greater than 60 seconds, or the vehicle speed exceeds 25 mph (40 km/h) the Entry/Exit change will be cancelled. To return to Normal Height Mode, press the “Up” button once while in Entry/Exit or drive the vehicle over 15 mph (24 km/h). Entry/Exit mode may not be available due to vehicle payload, an EVIC/DID message will be displayed when this occurs. Refer to "Electronic Vehicle Information Center (EVIC)/Driver Information Display (DID)" in "Understanding Your Instrument Panel" in the Owner's Manual on the DVD for further information.

Refer to your Owner's Manual on the DVD for further details.

Air Suspension Modes

The Air Suspension system has multiple modes to protect the system in unique situations:

Tire Jack Mode

To assist with changing a spare tire, the air suspension system has a feature which allows the automatic leveling to be disabled. Refer to “Electronic Vehicle Information Center (EVIC)/Driver Information Display (DID)” in “Understanding Your Instrument Panel” in the Owner's Manual on the DVD for further information.

NOTE:

This mode is intended to be enabled with engine running.

OPERATING YOUR VEHICLE

Transport Mode

To assist with flat bed towing, the air suspension system has a feature which will put the vehicle into Entry/Exit height and disable the automatic load leveling system. Refer to “Electronic Vehicle Information Center (EVIC)/Driver Information Display (DID)” in “Understanding Your Instrument Panel” in the Owner’s Manual on the DVD for further information.

NOTE:

This mode is intended to be enabled with engine running.

Wheel Alignment Mode

Before performing a wheel alignment this mode must be enabled. Refer to “Electronic Vehicle Information Center (EVIC)/Driver Information Display (DID)” in “Understanding Your Instrument Panel” in the Owner’s Manual on the DVD for further information.

NOTE:

This mode is intended to be enabled with engine running.

Protection Mode

In order to “protect” the air suspension system, the vehicle will enter Protection Mode when the payload has been exceeded or load leveling cannot be achieved. Refer to “Electronic Vehicle Information Center (EVIC)/Driver Information Display (DID)” in “Understanding Your Instrument Panel” in the Owner’s Manual on the DVD for further information.

NOTE:

This mode is intended to be enabled with engine running.

OPERATING YOUR VEHICLE

2500-3500 AIR SUSPENSION SYSTEM

The air suspension system provides full time rear load leveling capability for all loading conditions including towing.

Description

Normal Ride Height (NRH) - This is the standard position of the suspension and is meant for normal driving.

Trailer Mode (Lowers the vehicle approximately 1 in (25 mm)) - This position will lower the rear suspension and provide load leveling for all loading conditions including towing a trailer. After the “ALT TRAILER HEIGHT” button has been



Alt Trailer Height Button

pushed, it will blink continuously until the trailer height has been achieved. The system requires that the ignition be in the ON/RUN position or the engine running with zero vehicle speed for all user requested changes. After the engine is turned off, it may be noticed that the air suspension system operates briefly, this is normal. The system is correcting the position of the vehicle to ensure a proper appearance.

Trailer Decoupling/Unloading - The air suspension system will load level (lower/exhaust only) for up to 10 minutes after the vehicle is turned off. This allows for easy removal of a trailer and/or load from the back of the truck by maintaining the ride height. After 10 minutes you will need to turn the ignition to the run position for the air suspension to maintain ride height. If the air suspension system is disabled using the settings menu (Tire Jack Mode, Transport Mode or Alignment Mode) the system will remain disabled when the vehicle is turned off. Reactivating the air suspension can be accomplished via the settings menu or driving the vehicle above 5 mph (8 km/h) for Tire Jack Mode or Alignment Mode and 16 mph (26 km/h) for Transport Mode.

NOTE:

While loading, engine must be running for air suspension to maintain the ride height.

Refer to your Owner's Manual on the DVD for further details.

OPERATING YOUR VEHICLE

Air Suspension Modes

The Air Suspension system has multiple modes to protect the system in unique situations:

Tire Jack Mode

To assist with changing a spare tire, the air suspension system has a feature which allows the automatic leveling to be disabled. Refer to “Electronic Vehicle Information Center (EVIC)/Driver Information Display (DID)” in “Understanding Your Instrument Panel” in the Owner’s Manual on the DVD for further information.

NOTE:

This mode is intended to be enabled with engine running.

Transport Mode

To assist with flat bed towing, the air suspension system has a feature which will put the vehicle into Entry/Exit height and disable the automatic load leveling system. Refer to “Electronic Vehicle Information Center (EVIC)/Driver Information Display (DID)” in “Understanding Your Instrument Panel” in the Owner’s Manual on the DVD for further information.

NOTE:

This mode is intended to be enabled with engine running.

Wheel Alignment Mode

Before performing a wheel alignment this mode must be enabled. Refer to “Electronic Vehicle Information Center (EVIC)/Driver Information Display (DID)” in “Understanding Your Instrument Panel” in the Owner’s Manual on the DVD for further information.

NOTE:

This mode is intended to be enabled with engine running.

Protection Mode

In order to “protect” the air suspension system, the vehicle will enter Protection Mode when the payload has been exceeded or load leveling cannot be achieved. Refer to “Electronic Vehicle Information Center (EVIC)/Driver Information Display (DID)” in “Understanding Your Instrument Panel” in the Owner’s Manual on the DVD for further information.

NOTE:

This mode is intended to be enabled with engine running.

OPERATING YOUR VEHICLE

MANUAL CLIMATE CONTROLS WITHOUT TOUCHSCREEN



Manual Climate Controls

- | | |
|-----------------------------------|---------------------------|
| 1 — Rotate Blower Control | 4 — Push A/C Button |
| 2 — Push Air Recirculation Button | 5 — Rotate Mode Control |
| 3 — Rotate Temperature Control | 6 — Push Defroster Button |

Air Recirculation /Max A/C

- Use Recirculation for maximum A/C operation.
- For window defogging, turn the Recirculation button off.
- Recirculation is not allowed in defrost.
- Recirculation is allowed in floor mode and defrost/floor (mix modes) for approximately five minutes.

Heated Mirrors

The mirrors are heated to melt frost or ice. This feature is activated whenever you turn on the defroster.

OPERATING YOUR VEHICLE

MANUAL CLIMATE CONTROLS WITH TOUCHSCREEN



Uconnect® 8.4 Manual Climate Controls

- | | |
|------------------------------|----------------------------------|
| 1 — Max A/C Indicator | 6 — Blower Speed Up Button |
| 2 — A/C Button | 7 — Mode Control Buttons |
| 3 — Air Recirculation Button | 8 — Blower Speed Down Button |
| 4 — Front Defroster Button | 9 — OFF Button |
| 5 — Rear Defroster Button | 10 — Temperature Control Buttons |

OPERATING YOUR VEHICLE



Climate Control Knobs

- 1 — A/C Button
- 2 — Temperature Control Buttons
- 3 — Front Defroster Button
- 4 — Rear Defroster Button

- 5 — Rotate Blower Control
- 6 — OFF Button
- 7 — Air Recirculation Button

Air Recirculation

- Use Recirculation for maximum A/C operation.
- For window defogging, turn the Recirculation button off.

Heated Mirrors

The mirrors are heated to melt frost or ice. This feature is activated whenever you turn on the defroster.

OPERATING YOUR VEHICLE

AUTOMATIC CLIMATE CONTROLS WITH TOUCHSCREEN



Touchscreen Automatic Climate Controls

- | | |
|------------------------------|--------------------------------|
| 1 — MAX A/C Button | 8 — Passenger Temperature Down |
| 2 — A/C Button | 9 — SYNC Button |
| 3 — Air Recirculation Button | 10 — Blower Control Buttons |
| 4 — AUTO Button | 11 — Mode Control Button |
| 5 — Front Defroster Button | 12 — OFF Button |
| 6 — Rear Defroster Button | 13 — Driver Temperature Down |
| 7 — Passenger Temperature Up | 14 — Driver Temperature Up |

OPERATING YOUR VEHICLE



Climate Control Knobs

- | | |
|------------------------------|--------------------------------|
| 1 — A/C Button | 7 — Rear Defroster Button |
| 2 — Driver Temperature Up | 8 — Passenger Temperature Down |
| 3 — OFF Button | 9 — AUTO Button |
| 4 — Blower Control Knob | 10 — Driver Temperature Down |
| 5 — Passenger Temperature Up | 11 — Recirculation Button |
| 6 — Front Defroster Button | |

Air Conditioning (A/C)

- If the air conditioning button is pressed while in AUTO mode, the system will exit AUTO mode and stay in A/C. The mode and blower will be set at the closest mode and blower position that the system was operating in AUTO.

SYNC Temperature Button

- Press the “SYNC” button on the Uconnect® radio touchscreen to control the driver and passenger temperatures simultaneously. Press the “SYNC” button on the touchscreen a second time to control the temperatures individually.

OPERATING YOUR VEHICLE

Air Recirculation

- Use Recirculation for maximum A/C operation.
- For window defogging, turn the Recirculation button off.
- If the Recirculation button is pushed while in the AUTO mode, the indicator light may flash three times to indicate the cabin air is being controlled automatically.

Heated Mirrors

The mirrors are heated to melt frost or ice. This feature is activated whenever you turn on the defroster.

PARKSENSE® FRONT AND REAR PARK ASSIST

ParkSense® can be enabled and disabled by pressing the ParkSense® switch located below the climate controls, on the switch panel.

The four ParkSense® sensors, located in the rear fascia/bumper, monitor the area behind the vehicle that is within the sensors' field of view. The sensors can detect obstacles from approximately 12 in (30 cm) up to 79 in (200 cm) from the rear fascia/bumper in the horizontal direction, depending on the location, type and orientation of the obstacle.

The six ParkSense® sensors, located in the front fascia/bumper, monitor the area in front of the vehicle that is within the sensors' field of view. The sensors can detect obstacles from approximately 12 in (30 cm) up to 47 in (120 cm) from the front fascia/bumper in the horizontal direction, depending on the location, type and orientation of the obstacle.

When an object is detected within 2 meters behind the rear bumper while the vehicle is in REVERSE, a warning will display in the Electronic Vehicle Information Center (EVIC) or Driver Information Display (DID). In addition a chime will sound (when Sound and Display is selected from the Customer Programmable Features section of the Uconnect® System screen). As the vehicle moves closer to the object, the chime rate will change from single 1/2 second tone (for rear only), to slow (for rear only), to fast, to continuous.

Refer to your Owner's Manual on the DVD for further details.

Cleaning The ParkSense® Sensors

If "PARKSENSE UNAVAILABLE WIPE REAR SENSORS" or "PARKSENSE UNAVAILABLE WIPE FRONT SENSORS" appears in the "Electronic Vehicle Information Center (EVIC) or Driver Information Display (DID)", clean the ParkSense® sensors with water, car wash soap and a soft cloth. Do not use rough or hard cloths. Do not scratch or poke the sensors. Otherwise, you could damage the sensors.

OPERATING YOUR VEHICLE

PARKVIEW® REAR BACK-UP CAMERA

- You can see an on-screen image of the rear surroundings of your vehicle whenever the shift lever is put into REVERSE. The ParkView® Rear Back-Up Camera image will be displayed in the rearview mirror or touchscreen display along with a caution note to “check entire surroundings” across the top of the screen. After five seconds this note will disappear.
- If the rearview mirror or touchscreen display appears foggy, clean the ParkView® camera located to the left of the tailgate handle.

WARNING!

Drivers must be careful when backing up; even when using the ParkView® Rear Back-Up Camera. Always check carefully behind your vehicle, and be sure to check for pedestrians, animals, other vehicles, obstructions, or blind spots before backing up. You must continue to pay attention while backing up. Failure to do so can result in serious injury or death.

POWER SLIDING REAR WINDOW

The switch for the power sliding rear window is located on the overhead console.

- Push the switch right to open the glass and pull the switch left to close the glass.



Power Sliding Rear Window Switch

OPERATING YOUR VEHICLE

POWER SUNROOF

- The power sunroof switch is located on the overhead console.

Opening Sunroof

Express Open

Press the switch rearward and release it within one-half second. The sunroof will fully open and stop automatically.

Manual Open

Press and hold the switch rearward to open the sunroof. Any release of the switch will stop the movement, and the sunroof will remain in a partially open position until the switch is pressed again.

Venting Sunroof

Press and release the button and the sunroof will open to the vent position.

This is called “Express Vent” and will occur regardless of sunroof position. During Express Vent operation, any movement of the switch will stop the sunroof.

Closing Sunroof

Express Closing

Press the switch forward and release it within one-half second. The sunroof will fully close automatically from any position.

Manual Closing

Press and hold the switch forward to close the sunroof. Any release of the switch will stop the movement, and the sunroof will remain in a partially closed position until the switch is pressed again.

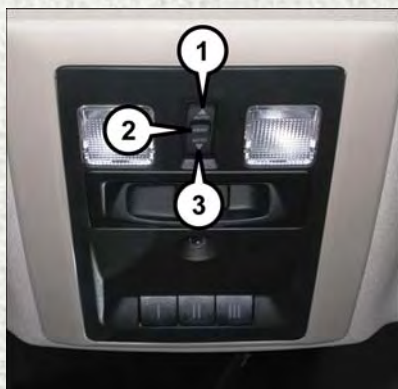

Power Sunroof Switch

- 1 — Opening Sunroof
 - 2 — Venting Sunroof
 - 3 — Closing Sunroof
-

Pinch Protection Feature

This feature will detect an obstruction in the opening of the sunroof during Express Close operation. If an obstruction in the path of the sunroof is detected, the sunroof will automatically retract. Remove the obstruction if this occurs. Next, press the switch forward and release to Express Close.

NOTE:

If three consecutive sunroof close attempts result in Pinch Protect reversals, the fourth close attempt will be a Manual Close movement with Pinch Protect disabled.

WARNING!

- Do not let children play with the sunroof. Never leave children unattended in a vehicle, or with access to an unlocked vehicle. Do not leave the Key Fob in or near the vehicle, and do not leave the ignition of a vehicle equipped with Keyless Enter-N-Go™ in the ACC or ON/RUN mode. Occupants, particularly unattended children, can become entrapped by the power sunroof while operating the power sunroof switch. Such entrapment may result in serious injury or death.
- In a collision, there is a greater risk of being thrown from a vehicle with an open sunroof. You could also be severely injured or killed. Always fasten your seat belt properly and make sure all passengers are properly secured.
- Do not allow small children to operate the sunroof. Never allow your fingers, other body parts, or any object to project through the sunroof opening. Injury may result.

WIND BUFFETING

Wind buffeting can be described as a helicopter-type percussion sound. If buffeting occurs with the rear windows open, adjust the front and rear windows together.

If buffeting occurs with the sunroof open, adjust the sunroof opening, or adjust any window. This will minimize buffeting.

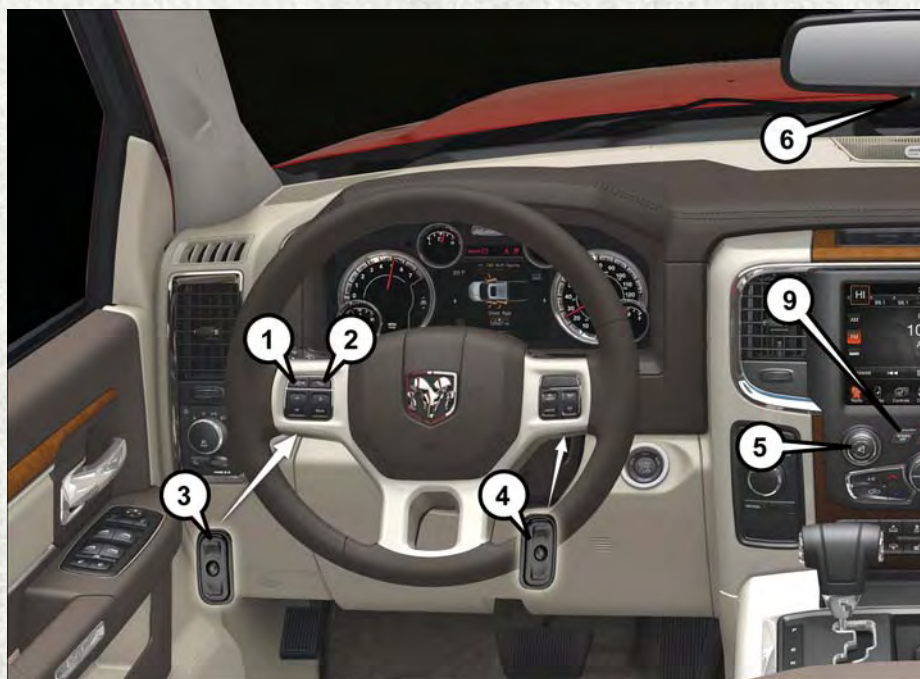

YOUR VEHICLE'S SOUND SYSTEM

1. Uconnect® Voice Command Button pg. 111
2. Uconnect® Phone Button pg. 139
3. Steering Wheel Audio Controls (Left) pg. 147
4. Steering Wheel Audio Controls (Right) pg. 147
5. Volume Knob/Audio Mute Button
6. Assist Button pg. 69

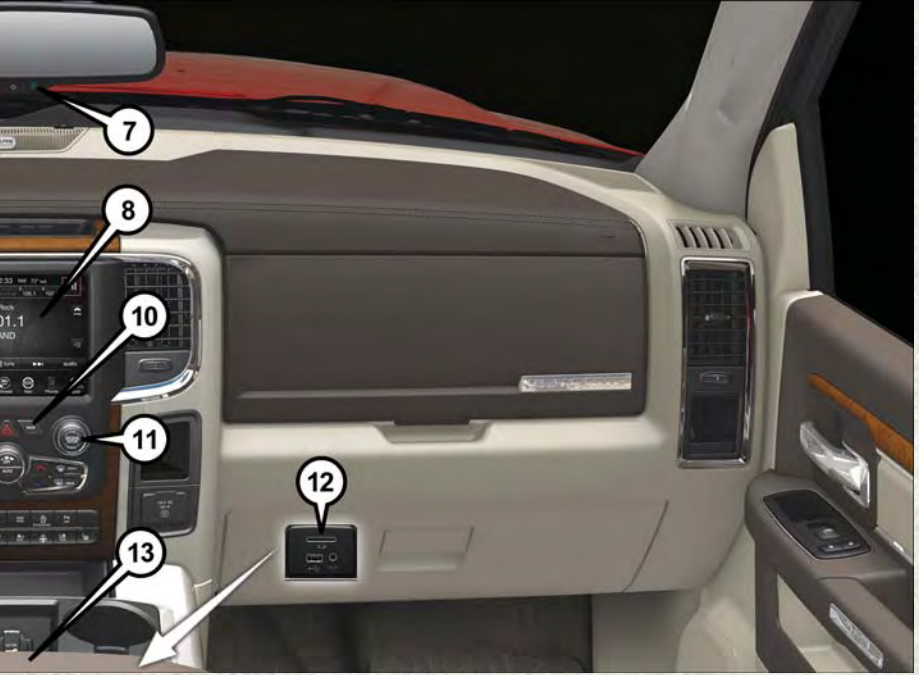

- 7. 9-1-1 Button pg. 69
- 8. Uconnect® 8.4 Radio pg. 95
- 9. Screen Off Button
- 10. Back Button
- 11. Tune/Scroll Knob/Browse/Enter Button
- 12. Media Hub: Audio Jack, USB Port, and SD Card Slot (located center console) pg. 101
- 13. CD Player (Inside Center Console — If Equipped) pg. 131

ELECTRONICS

IDENTIFYING YOUR RADIO

Uconnect® 3.0

- Two buttons on the faceplate on either side of the display



Uconnect® 3.0

Uconnect® 5.0

- 5" Touchscreen
- Three buttons on the faceplate on either side of the display



Uconnect® 5.0

Uconnect® 8.4A

- 8.4" Touchscreen
- Climate button on the touchscreen in lower menu bar
- HD Button will NOT be visible on right side of screen when viewing AM or FM
- SiriusXM Travel Link feature NOT listed within Apps



Uconnect® 8.4A

Uconnect® 8.4AN

- 8.4" Touchscreen
- Climate button on the touchscreen in lower menu bar
- HD Button will be visible on right side of screen when viewing AM or FM
- SiriusXM Travel Link feature listed within Apps

**Uconnect® 8.4AN**

- 1 — HD Radio — Standard On Uconnect® 8.4AN
- 2 — Navigation — Standard On Uconnect® 8.4AN

UCONNECT® ACCESS**Uconnect® Access — If Equipped (Available On Uconnect® 8.4A/8.4AN — U.S. Residents Only)****WARNING!**

ALWAYS drive safely with your hands on the steering wheel. You have full responsibility and assume all risks related to the use of the Uconnect® features and applications in this vehicle. Only use Uconnect® when it is safe to do so. Failure to do so may result in an accident involving serious injury or death.

Uconnect® Access enhances your ownership and driving experience by connecting your vehicle with a built-in cellular connection. With Uconnect® Access, you can:

- Place a call to a local 9-1-1 Operator for emergency assistance.
- Remotely lock/unlock your doors and start your vehicle from virtually anywhere, using the Uconnect® Access App from your smartphone. You can also do so by logging into Mopar Owner Connect, or by calling Uconnect® Care. (Vehicle must be within the United States and have network coverage).
- Turn your vehicle into a WiFi Hotspot and connect your devices to the internet.
- Receive text or email notifications if your vehicle's theft alarm goes off.
- Receive stolen vehicle assistance, using GPS technology to help authorities locate your vehicle if it is stolen.

ELECTRONICS

- Listen to your text messages or send free-form text messages with your voice while keeping your hands on the wheel, using the Voice Texting feature. Requires a cell phone that supports Bluetooth Message Access Profile (MAP).
- Search for places to eat, shop, relax and play with Yelp®, using your voice or on-screen menu. Then navigate to them (navigation standard on Uconnect® 8.4AN, optional on Uconnect® 8.4A).
- Get operator assistance using the ASSIST button on your interior rearview mirror.

Before you drive, familiarize yourself with the easy-to-use Uconnect® Access.

1. The ASSIST and 9-1-1 buttons are located on your rearview mirror. The ASSIST button is used for contacting Roadside Assistance, Vehicle Care and Uconnect® Care. The 9-1-1 button connects you to emergency services.

NOTE:

Vehicles sold in Canada and Mexico DO NOT have 9-1-1 Call system capabilities. 9-1-1 or other emergency line operators in Canada and Mexico may not answer or respond to 9-1-1 system calls.

2. The Uconnect® “Apps” button on the menu bar at the bottom right corner of the radio touchscreen. This is where you can begin your registration process, manage your Apps and purchase WiFi on demand.
3. The Uconnect® Voice Command and Uconnect® Phone buttons are located on the left side of your steering wheel. These buttons let you use your voice to give commands, make phone calls, send and receive text messages hands-free, enter navigation destinations, and control your radio and media devices.

Included Trial Period For New Vehicles

Your new vehicle may come with an included trial period for use of the Uconnect® Access Services starting at the date of vehicle purchase (date based on vehicle sales notification from your dealer). **To activate the trial, you must first register with Uconnect® Access.** After the trial period, if you wish to continue your Uconnect® Access Services you can choose to purchase a subscription.

Features And Packages

- After the trial period, you can subscribe to continue your service by visiting the Uconnect® Store located within the Mopar Owner Connect website moparownerconnect.com. If you need assistance, U.S. residents can call Uconnect® Care at 1-855-792-4241.
- For the latest information on packages and pricing information: U.S. residents visit DriveUconnect.com.

Uconnect® Access Registration (Uconnect® 8.4A/8.4AN, U.S. 48 Contiguous States, Alaska And Hawaii)

To unlock the full potential of Uconnect® Access in your vehicle, you first need to register with Uconnect® Access.

1. From the parked vehicle with the radio touchscreen powered on, select the “Apps” button located near the bottom right-hand corner of the radio touchscreen.

NOTE:

Should you require assistance anytime during the registration process, simply call Uconnect® Care at 1-855-792-4241.

2. Press “Start” on the reminder screen or select “Uconnect Registration” under the “All Apps” or “Favorites Apps” tab on the Apps list.
3. The Uconnect® Access Registration App will open and display step-by-step instructions to start your registration.
4. Enter your email address into the radio touchscreen.
5. A message will display on the touchscreen indicating your email submission was accepted. In a few minutes, you will receive an email which will allow you to register your vehicle for Uconnect® Access. You should open this email and begin your Uconnect® Access registration within 72 hours.
6. Check for an email from Uconnect® Access that contains your personalized registration link. If you don't see it, check your spam or junk mail folder. Open the email and click on the link to continue registering.

NOTE:

For security reasons, this link is valid for 72 hours from the time you've submitted your email address into the radio touchscreen. If the link has expired, simply re-enter your email address into the Uconnect® Registration App on the radio touchscreen to receive another link. The secured registration link will take you through the Uconnect® Access registration process step by step.

7. To unlock the full potential of Uconnect® Access in your vehicle, you will need to create or validate an existing Mopar Owner Connect account previously (Owner Center). Uconnect® along with Mopar Owner Connect have joined forces to create one destination to manage all of your vehicle needs, from managing your Uconnect® Access account, to tracking service history and finding recommended accessories for your vehicle. If you already have a Mopar Owner Connect account, log in to the website with your existing username/email and password. For assistance with this web based registration process, call Uconnect® Care at 1-855-792-4241.

8. Once you are logged in to your Mopar Owner Connect account, you will create a personal Uconnect® Security PIN. The Uconnect® Security PIN will be required to authenticate you when accessing your account via Uconnect® Care or performing any remote services such as Remote Door Lock/Unlock, Remote Horn & Lights or Starting and Stopping the engine.
9. If your vehicle qualifies for a trial package it will be presented. Simply agree to the Uconnect® Terms of Service (checkbox) and then select the “Start Service” button.

At this point your vehicle is registered with Uconnect® Access. Continue to set up Via Mobile. Apps will be downloaded the next time you start your vehicle. If the Apps have not appeared after 24 hours, please contact Uconnect® Care.

Download The Uconnect® Access App

The Uconnect® Access smartphone App allows you to remotely lock or unlock your doors, start your engine (if equipped) and activate your horn and lights from virtually anywhere. The smartphone App also features Via Mobile (if equipped) which uses your smartphone's data plan to access your personal Pandora®, iHeartRadio, Slacker Radio and Aha™ by HARMAN accounts and control them using your vehicle touchscreen.

The Uconnect® Access app is only compatible with select iPhone® and Android smartphones. Visit UconnectPhone.com or call 1-877-855-8400 to confirm that your smartphone is compatible with Uconnect®. Once you've confirmed your smartphone is compatible, Android and iPhone® users should visit their respective app store and search for “Uconnect Access” to download the app.

Set Up Your Via Mobile Profile — If Equipped

Setting up your Via Mobile profile means entering your login information for each App so that they can work in your vehicle. Complete your Via Mobile Profile online during registration of your Uconnect® Access system. Access this page by logging into your Mopar Owner Connect account (moparownerconnect.com), going to Edit Profile, then Via Mobile Profile.

If you already have an account with these Apps, scroll down and press the “Link” button to enter your information. If you do not have an account, you can create a new one.

Aha™ by HARMAN (www.aharadio.com)

- Enter your email address and password for Aha™, or create a new Aha™ account.
- You can link your Facebook, Twitter or Slacker accounts on the Aha™ website.

iHeartRadio (www.iHeartRadio.com)

- Enter your email address and password for iHeartRadio, or create a new iHeartRadio account.
- Select “Activate” to continue,
- Select “Close” to complete activation.

Pandora® (www.pandora.com)

- Enter your Pandora® username/email address and password, then click “Save.”
- Create a new Pandora® account.

Slacker Radio (www.slacker.com)

- Enter your Slacker username/email address and password, then click “Save.”
- Create a new Slacker Radio account.

Invite family and friends to use the Via Mobile Apps in your vehicle by setting up their own Via Mobile profile.

Renewing Subscriptions And Purchasing WiFi Hotspot (Uconnect® 8.4A/8.4AN, U.S. 48 Contiguous States And Alaska)

Subscriptions, and WiFi Hotspot, can be purchased from the Uconnect® Store within your vehicle, and online at Mopar Owner Connect. If you need help push the ASSIST button on the rearview mirror, then select Uconnect® Care (or dial 1-855-792-4241).

Purchasing Online

You can renew your subscription to a package or purchase WiFi from the Mopar Owner Connect website. You must first set up a Uconnect® Access Payment Account online. Log into moparownerconnect.com

1. Log In to the Mopar Owner Connect website (moparownerconnect.com) with your username/email and password.
2. Click on the “Shop” tab, then click on the Uconnect® Store.
3. From the Uconnect® Store, select the item you wish to purchase.
4. This will launch the selected item into purchase mode along with providing additional information.
5. The Uconnect® Store will display a “Purchase Overview” message confirming the financial details of your purchase. Click the “Purchase” key to continue.
6. The Uconnect® Store will ask you to “Confirm Payment” using your default payment method on file in your Payment Account. Click the “Complete” key to continue.
7. The Uconnect® Payment Account will then ask for your “Payment Account PIN,” which you established when setting up your Uconnect® payment account. After entering this four digit PIN, click the “Complete” key to make the purchase.
8. You will receive a confirmation message that your purchase has been submitted. Click the “OK” button to end the process.

Purchasing WiFi Hotspot While In Your Vehicle

You must set up a Uconnect® Access Payment Account online (log in to moparownerconnect.com, go to Edit Profile, then Uconnect® Payment Account, to set up and manage your Payment Account).

1. To purchase WiFi while in your vehicle, ensure the vehicle is running and in Park. Press the “Apps” button on the touchscreen, then select WiFi within the “Apps” menu. Follow the on-screen instructions. When asked for your payment PIN, use the 4-digit PIN you established when setting up your payment account on Mopar Owner Connect.

NOTE:

This may be different than the Uconnect® Security PIN you established for using features such as Remote Vehicle Start. After purchasing WiFi, it may take up to 30 minutes (with the vehicle running) before the WiFi will be active in your vehicle.

2. Select WiFi again, then note the hotspot name. Select this network when connecting devices to the hotspot. Also click on View/Edit Passphrase, then note the security passphrase you will need to connect to the network on each device.

If your devices cannot see the WiFi Hotspot network after 30 minutes, please contact Uconnect® Care by pushing the ASSIST button on the rearview mirror, or by calling 1-855-792-4241.

Using Uconnect® Access

Getting Started With Apps

Applications (Apps) and features in your Uconnect® Access system deliver services that are customized for the driver and are certified by Chrysler Group, LLC. Two different types are:

1. **Built-In Features** — use the built-in 3G Cellular Network on your Uconnect® 8.4A/8.4AN radio.
2. **Uconnect® Access Via Mobile** (if equipped) — Via Mobile uses the Uconnect® Access App and your smartphone's data plan to access your personal Pandora®, iHeartRadio, Aha™ by HARMAN and Slacker Radio accounts from the vehicle and control them using the vehicle touchscreen. Customer's data plan charges will apply. Available on Uconnect® 8.4A and 8.4AN Radios (if equipped).

Get started with your Uconnect® Access apps by pressing the Uconnect® “Apps” button on the menu bar at the bottom right corner of the radio touchscreen. Available apps and features are organized by the tabs on the left of the screen:

Favorite Apps — This is the default screen when you first press the “Apps” button on the touchscreen, and is a good place to put the apps you use most frequently. To make an App a “favorite”, press the “Settings” button on the touchscreen to the right of the app, and select “Make a favorite.”

All Apps — Organizes your Uconnect® Access Apps (when available).

Running Apps — Press this tab to see which apps are currently running.

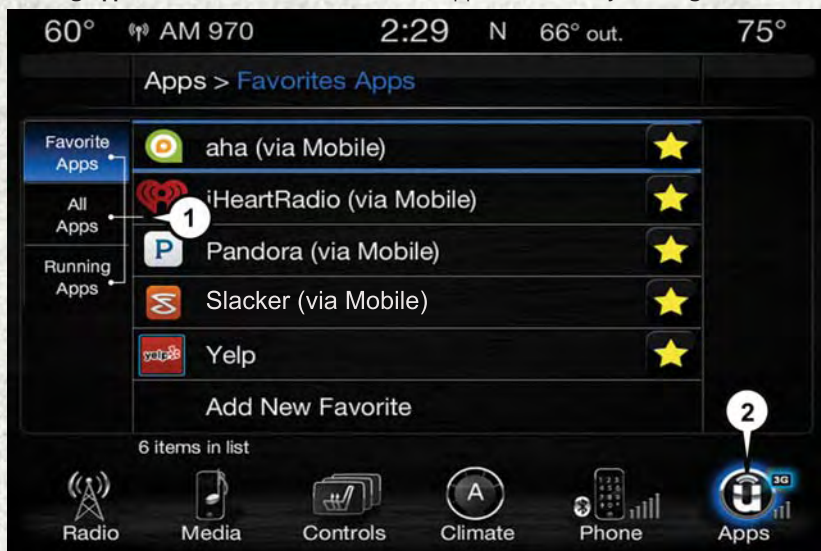

Favorite Apps

1 — Category Tabs

2 — Apps Button

Maintaining Your Uconnect® Access Account

Reinstalling An App (Uconnect® 8.4A/8.4AN)

You can easily correct many Application related issues you may be experiencing by resetting the App back to the factory setting. From the vehicle's radio touchscreen, complete the following steps:

1. Press the Uconnect® "Apps" button and open the Uconnect® Store. Go to My Apps.
2. In My Apps, select "Settings," then "Reinstall App." Press "Continue."
3. Your Apps have been successfully re-installed.

Canceling Your Subscription

Should you want to cancel your subscription, you can remove your account information using the same procedure contained in the Selling Your Vehicle section.

Selling Your Vehicle

When you sell your vehicle, we recommend that you remove your Uconnect® Access Account information from the vehicle. You can do this using the radio touchscreen in the vehicle or on the Mopar Owner Connect website (moparownerconnect.com). Removing your account information cancels your subscription and makes your vehicle factory-ready for a new owner/subscriber.

1. From your vehicle's radio touchscreen, select "Uconnect® Store" from the Apps Menu.
2. Select "My Apps," then "Settings." Press "Remove Uconnect® Account."
3. Enter your Uconnect® Security PIN, and select "Continue."

For additional information on Uconnect®:

- U.S. residents - visit DriveUconnect.com or call 1-877-855-8400.
- Canadian Residents - visit DriveUconnect.ca or call, 1-800-465-2001 (English) or 1-800-387-9983 (French).

Built-In Features (Uconnect® 8.4AN Only)**CAUTION!**

- Ignoring the rearview mirror light could mean you may not have 9-1-1 Call service if needed. If the rearview mirror light is illuminated, have an authorized dealer service the 9-1-1 Call system immediately.
- The Occupant Restraint Controller (ORC) turns on the Air Bag Warning Light on the instrument panel if a malfunction is detected in any part of the air bag system. If the Air Bag Warning Light is illuminated, the air bag system may not be working properly and the 9-1-1 system may not be able to send a signal to a 9-1-1 operator. If the Air Bag Warning Light is illuminated, have an authorized dealer service your vehicle immediately.
- If anyone in the vehicle could be in danger (e.g., fire or smoke is visible, dangerous road conditions or location), do not wait for voice contact from a 9-1-1 operator. All occupants should exit the vehicle immediately and move to a safe location.
- Do not add any aftermarket electrical equipment to the vehicle's electrical system. This may prevent your vehicle from sending a signal to initiate an emergency call. To avoid interference that can cause the 9-1-1 Call system to fail, never add aftermarket equipment (e.g., two-way mobile radio, CB radio, data recorder, etc.) to your vehicle's electrical system or modify the antennas on your vehicle. IF YOUR VEHICLE LOSES BATTERY POWER FOR ANY REASON (INCLUDING DURING OR AFTER AN ACCIDENT), THE UCONNECT® FEATURES, APPS AND SERVICES, AMONG OTHERS, WILL NOT OPERATE.

1. **Assist Call** – The rearview mirror contains an ASSIST push button which automatically connects the vehicle occupants to one of these predefined destinations for immediate support:

- **Roadside Assistance Call** — If you get a flat tire, or need a tow, you'll be connected to someone who can help anytime. Additional fees may apply. Additional information in this section.
- **Uconnect® Access Care** — In vehicle support for Uconnect® Access System, Apps and Features.
- **Vehicle Care** — Total support for your Chrysler Group LLC vehicle.



ASSIST/9-1-1 Buttons

- 1 — ASSIST Button
2 — 9-1-1 Button

2. **Emergency 9-1-1 Call (If Equipped)** — The rearview mirror contains a 9-1-1 button that, when pressed, may place a call from your vehicle to a local 9-1-1 operator to request help from local police, fire or ambulance personnel. If this button is accidentally pressed, you will have 10 seconds to stop the call. To cancel, press the 9-1-1 Call button again or press the “Cancel” button shown on the touchscreen. After 10 seconds has passed, the 9-1-1 call will be placed and only the 9-1-1 operator can cancel it. The LED light on the rearview mirror will turn green once a connection to a 9-1-1 operator has been made. The green LED light will turn off once the 9-1-1 call is terminated. Have an authorized dealer service the vehicle if the rearview mirror light is continuously red. On equipped vehicles, this feature requires a functioning electrical system and wireless coverage to function properly. **If a connection is made between a 9-1-1 operator and your vehicle, you understand and agree that 9-1-1 operators may, like any other 9-1-1 call, record conversations and sounds in and near your vehicle upon connection.**
3. **Roadside Assistance (If Equipped)** — If your vehicle is equipped with this feature and within wireless range, you may be able to connect to Roadside Assistance by pressing the “ASSIST” button on the rearview mirror. You will be presented with Assist Care options. Make a selection by pressing the prompts displayed on the radio. If Roadside Assistance is provided to your vehicle, you agree to be responsible for any additional roadside assistance service costs that you may incur. In order to provide Uconnect® Services to you, we may record and monitor your conversations with Roadside Assistance, Uconnect® Care or Vehicle Care, whether such conversations are initiated through the Uconnect® Services in your vehicle, or via a landline or mobile telephone, and may share information obtained through such recording and monitoring in accordance with regulatory requirements. You acknowledge, agree and consent to any recording, monitoring or sharing of information obtained through any such call recordings.
4. **Yelp®** — Customers have the ability to search for nearby destinations or a point of interest (POI) either by category or custom search by using keywords (for example, “Italian restaurant”). Searching can be done by either voice or by using the touchscreen keypad. Using the touchscreen, launch Yelp® by selecting the “Apps” icon. Press the “All Apps” tab, and then press “Yelp.” To use voice recognition, push the VR button on the steering wheel and say “launch Yelp®,” then follow the instructions on the Teleprompter.
5. **Security Alarm Notification** — The Security Alarm Notification feature notifies you via email or text (SMS) message when the vehicle’s factory-installed security alarm system has been set-off. There are a number of reasons why your alarm may have been triggered, one of which could be that your vehicle was stolen. If so, please see the details of the Stolen Vehicle Assistance service below. When you register, Security Alarm Notification is automatically set to send you an email at the mail address you provide should the alarm go off. You may also opt to have a text message sent to your mobile device.

- 6. Stolen Vehicle Assistance** — If your vehicle is stolen, contact local law enforcement immediately to file a stolen vehicle report. Once this report has been filed, Uconnect® care can help locate your vehicle. The Uconnect® Care agent will ask for the stolen vehicle report number issued by local law enforcement. Then, using GPS technology and the built-in wireless connection within your vehicle, the Uconnect® Care agent will be able to locate the stolen vehicle and work with law enforcement to help recover it. (Vehicle must be within the United States, have network coverage and must be registered with Uconnect® Access with an active subscription that includes the applicable feature).
- 7. WiFi Hotspot** — WiFi Hotspot is on-demand WiFi 3G connectivity that's built-in and ready to go where ever you are. Once your vehicle is registered for Uconnect® Access, you can purchase a Wifi Hotspot subscription at the Uconnect® Store. After you've made your purchase, turn on your signal and connect your passengers devices. It's never been easier to bring your home or office with you.

NOTE:

Your vehicle must have a working electrical system for any of the in vehicle Uconnect® features to operate.

Uconnect® Access Remote Features

If you own a compatible iPhone® or Android® powered device, the Uconnect® Access App allows you to remotely lock or unlock your doors, start your engine or activate your horn and lights from virtually anywhere (Vehicle must be within the United States and have network coverage). You can download the App from Mopar Owner Connect or from the App Store (iPhone) or Google Play store. Visit UconnectPhone.com to determine if your device is compatible. For Uconnect® Phone customer support and to determine if your device is compatible.

U.S. residents - visit UconnectPhone.com or call 1-877-855-8400

Remote Start — This feature provides the ability to start the engine on your vehicle, without the keys and from virtually any distance. You can send a request to your vehicle in one of two ways:

1. Using the Uconnect® Access App from a compatible smartphone.
2. From the Mopar Owner Connect website.
 - After 15 minutes if you have not entered your vehicle with the key, the engine will shut off automatically.
 - You can also send a command to turn-off an engine that has been remote started.
 - This remote function requires your vehicle to be equipped with a factory-installed Remote Start system. To utilize this feature after the Uconnect® Access App is downloaded, login with your user name and password.

NOTE:

Your four digit Uconnect® Security PIN is required to confirm the request.

- You can set-up notifications for your account to receive an email or text (SMS) message every time a command is sent. Login to Mopar Owner Connect (moparownerconnect.com) and click on Edit Profile to manage Uconnect® Notifications.

Remote Door Lock/Unlock — This feature provides the ability to lock or unlock the door on your vehicle, without the keys and from virtually any distance. You can send a request to your vehicle in one of three ways:

1. Using the Uconnect® Access App from a compatible smartphone.
2. From the Mopar Owner Connect website.
3. By contacting the Uconnect® Care on the phone.

To use this feature after the Uconnect® Access App is downloaded, login using your user name and password. You will need your four digit Uconnect® Security PIN to confirm the request. Press the “closed lock” icon on your Uconnect® Access App to lock the doors, and press the “open Lock” icon to unlock the driver’s door.

You can set-up notifications for your account to receive an email or text (SMS) message every time a command is sent. Login to Mopar Owner Connect (moparownerconnect.com) and click on Edit Profile to manage Uconnect® Notifications.

Remote Horn And Lights — It’s easy to locate a vehicle in a dark, crowded or noisy parking area by activating the horn and lights. It may also help if you need to draw attention to your vehicle for any reason. You can send a request to your vehicle in one of three ways:

1. Using the Uconnect® Access App from a compatible smartphone.
2. From the Mopar Owner Connect website.
3. By contacting the Uconnect® Care on the phone.

To use this feature after the Uconnect® Access App is downloaded, login using your user name and password. You will need your four digit Uconnect® Security PIN to confirm the request. You can set-up notifications for your account to receive an email or text (SMS) message every time a command is sent. Login to Mopar Owner Connect (moparownerconnect.com) and click on Edit Profile to manage Uconnect® Notifications.

Voice Texting — Want to dictate a personal message? Register with Uconnect® Access to take advantage of a new, cloudbased Voice Texting service, an enhancement to Voice Text Reply.

Voice Texting allows you to compose a new text or reply to an incoming text message. Before you attempt to use the Voice Texting feature, check to ensure you have the following:

1. A paired, Bluetooth® enabled phone with the Message Access Profile (MAP). Not all Bluetooth® enabled phones support MAP, including all iPhones® (Apple iOS). Visit UconnectPhone.com for system and device compatibility information.
2. An active Uconnect® Access trial or paid subscription. Press the “Apps” button on the lower right hand corner of the touchscreen to begin the registration process.
3. Accept the “Allow MAP” profile request on your smart phone. (Please refer to device manufacturer instructions for details).

To Send A Text Message:

1. Push the Uconnect® Phone Button  on the steering wheel.
2. Wait for the beep.
3. Say “Text.”
4. Uconnect® will prompt you “Say the phone number, or full name and phone type of the contact you want to send a message to.”
5. Wait for the beep and say a contact that is in your phonebook, or a mobile phone number that you would like to send the message to.
6. Uconnect® will prompt you “Please say the message that you would like to send.” (If you do not hear this prompt, you may not have an active subscription with Uconnect® Access).
7. Wait for the beep, and then dictate any message up to 140 characters. If you exceed 140 characters, you will hear the following prompt: “Message was too long; your message will be truncated.”
8. Uconnect® will then repeat the message back to you.
9. Uconnect® will prompt you: “To add to your message, say “Continue”; To delete the current message and start over, say “Start Over”; to send the current message, say “Send”; to hear the message again, say “Repeat”.
10. If you are happy with your message and would like to send it, wait for the beep and say “Send”.
11. Uconnect® will then say “Sending your message.”

Sample Commands For Voice Text Reply And Voice Texting

Example Command	Action
"Text John Smith"	Send a message to specific contact in address book
"Text 123 - 456 - 7890"	Send 123 - 456 - 7890 a message from your phonebook
"Show messages"	See recent text messages listed by number on Uconnect® screen
"Listen to/view (message number four, for example)"	Hear messages or read it on Uconnect® screen
"Reply"	Send a voice text reply to a current message
"Forward text/message to "John Smith"	Forward current text to specific contact in address book
"Forward text/message to "123 - 456 - 7890"	Forward current text to specific phone number

Uconnect® Access Via Mobile — If Equipped (Available On Uconnect® 8.4AN)

Via Mobile uses the Uconnect® Access App and your smartphone's data plan to access your personal Pandora®, iHeartRadio, Aha™ by HARMAN and Slacker Radio accounts from the vehicle and control them using the vehicle touchscreen. Customer's data plan charges will apply.

To get started using Via Mobile Apps, first register your Uconnect® Access system where you'll be guided through the setup of your Via Mobile (requires a compatible Android or iPhone® smartphone). Please refer to "Uconnect® Access Registration" for more information.

The Uconnect® Access App is compatible with select iPhone® and Android smartphones. Visit UconnectPhone.com to confirm that your smartphone is compatible with Uconnect®. Once you've confirmed your smartphone is compatible, pair it to the vehicle touchscreen via Bluetooth® to use Via Mobile apps. If using an iPhone®, a USB cable is also supported for the data connection.

Launch the Uconnect® Access App on your smartphone, and login with your username and password that was set up during registration, (this is your moparownerconnect.com login). Accept the Terms and Conditions.

- Ensure that Via Mobile data has been turned on under “Settings” in the Uconnect® Access App.
- A green indicator next to the words Via Mobile will show when it is ready to provide data to the radio (a blue indicator when data is being sent). A red indicator means that it is not ready to provide data.
- On android phones, an orange/yellow indicator signals the phone is connected to the appropriate servers, however Bluetooth® is turned off on the mobile phone.

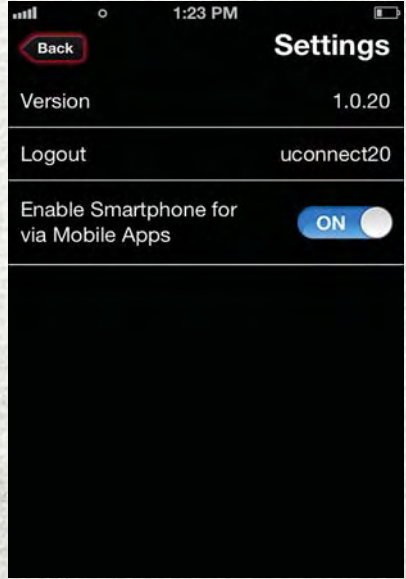

Via Mobile Data Enabled

ELECTRONICS

Each time you want to use a Via Mobile app in your vehicle, the Uconnect® Access App must be running on your smartphone and the smartphone must be paired via Bluetooth®.

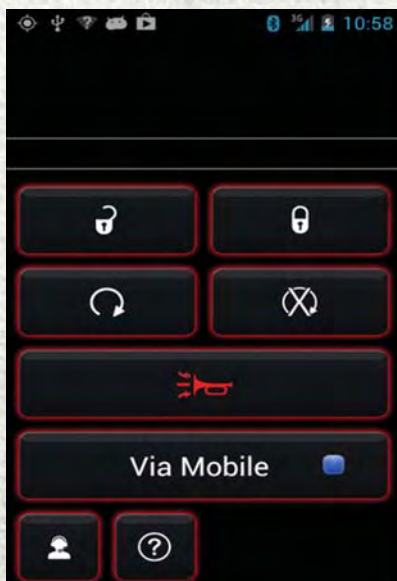

Data Being Sent

If equipped, the Via Mobile apps can be found by selecting the “Apps” button on the touchscreen in the lower right corner of the radio touchscreen. Via Mobile apps are listed under the “All Apps” or “Favorite Apps” tab. The words “Via Mobile” will appear after the app name indicating it is a Via Mobile app.

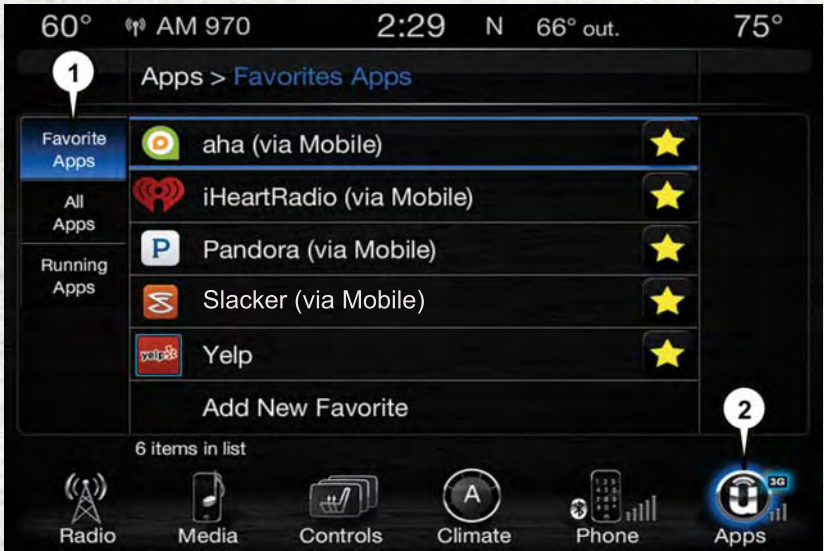

Favorite Apps

1 — Favorite Tab

2 — Apps Button

Via Mobile apps can also be launched through Voice Recognition by pressing the VR button on the steering wheel and stating “launch” and then the name of the app. For example, you can say “launch Aha Via Mobile.”

NOTE:

For detailed information on how to use Via Mobile apps visit the Mopar Owner Connect website (moparownerconnect.com) and login using the username and password you set up when registering for Uconnect® Access.

A message will be displayed to remind you that Via Mobile apps utilize the data plan on your connected smartphone to provide content. Many smartphones have a limit to how much data they can utilize before incurring additional charges. The amount of data being used varies by smartphone device, cellular service provider and specific app. Check your mobile phone service plan for more details. * Press “OK” to continue or the “X” to exit.

(*Additional smartphone data usage charges may apply.)

Via Mobile Apps — If Equipped

- **Aha™ by HARMAN** — Aha™ by HARMAN makes it easy to instantly access your favorite Web content on the go. Choose from over 40,000+ stations spanning internet radio, personalized music, news, entertainment, hotels, weather, audio-books, Facebook®, Twitter®, and more.
- **iHeartRadio** — iHeartRadio provides instant access to more than 1,500 live radio stations from across the country and allows listeners to create custom music stations inspired by their favorite artists or songs.
- **Pandora®** — Pandora® gives people the music and comedy they love anytime, anywhere. Personalized stations launch instantly, with the input of a favorite artist, track, comedian, or genre.
- **Slacker Radio** — Enjoy millions of songs and hundreds of handcrafted stations.

NOTE:

For detailed information on how to use Via Mobile apps visit the Mopar Owner Connect website (moparownerconnect.com) and log in using the username and password you set up when registering for Uconnect® Access.

UCONNECT® 3.0



Uconnect® 3.0 Radio

- | | |
|------------------------------|---|
| 1 — RADIO Button | 8 — SEEK Up Button |
| 2 — INFO Button | 9 — ON/OFF Button/Volume Knob |
| 3 — MEDIA Button | 10 — BROWSE/ENTER Button/
TUNE/SCROLL Knob |
| 4 — A-B-C Button | 11 — AUDIO Button |
| 5 — Preset Buttons | 12 — MENU Button |
| 6 — SEEK Down Button | 13 — BACK Button |
| 7 — Play/Pause — Mute Button | |

Clock Setting

1. Press the Menu button at the bottom of the radio, and push the Enter/Browse button for System Settings. Next, select the Time and Format setting and then select Set Time by pushing the Enter/Browse button.
2. Adjust the hours or minutes by turning the Tune/Scroll knob, then pressing the Enter/Browse button to move to the next entry. You can also select 12hr or 24hr format by turning the Tune/Scroll knob, then pressing the Enter/Browse button on the desired selection.
3. Once the time is set press the “Back” button to exit the time screen.

Audio

- Push the AUDIO button on the radio faceplate.
- The Audio Menu shows the following options for you to customize your audio settings.

Treble, Mid, Bass, Fade, Balance, Speed Adjusted Volume, Loudness and Auto Volume Offset

- Select the desired setting to adjust, then push the ENTER/BROWSE button. Turn the TUNE/SCROLL knob to adjust the setting + or - 9. Push the “Back” button when done.

Radio Operation

Seek Up/Down Buttons

- Push to seek through radio stations in AM, FM or SXM bands.
- Hold either button to bypass stations without stopping.

Store Radio Presets

- The Presets are available for all Radio Modes, and are activated by pushing any of the six Preset buttons.
- When you are receiving a station that you wish to commit into memory, push and hold the desired numbered button for more than two seconds, or until you hear a confirmation beep.
- The Radio stores up to 18 presets in each of the Radio modes. Push the A-B-C button on the faceplate to select the A, B or C preset list.

Disc Operation (If Equipped)

Your vehicle may have a remote CD player located in the lower center console storage bin, or in the lower center bench seat bin.

- CD/Disc Mode is entered by either inserting a CD/Disc or by pushing the MEDIA button located on the side of the display. Once in Media Mode, select “Disc.”

Gently insert one CD into the CD player with the CD label facing as indicated on the illustration located on the Disc player.

Seek Up/Down Buttons

- Push to seek through CD tracks.
- Hold either button to bypass tracks without stopping.

USB/Audio Jack (AUX) Operation

USB/iPod®

- USB/iPod® Mode is entered by either inserting a USB Jump Drive or iPod® cable into the USB port or by pressing the MEDIA button located left of the display. Once in Media Mode, select “USB/iPod” for the source.
- Press the MEDIA button, then select “USB/iPod” to change the mode to the USB device if the device is connected, allowing the music from your portable device to play through the vehicle's speakers.

Audio Jack (AUX)

The AUX allows a portable device such as an MP3 player or an iPod® to be plugged into the radio and utilize the vehicle's audio system, using a 3.5 mm audio cable, to amplify the source and play through the vehicle's speakers.

- If the audio cable is connected to the AUX jack and portable device, press the MEDIA button, then press the “Source” button on the touchscreen and select “AUX” to change the mode to auxiliary device. This allows the music from your portable device to play through the vehicle's speakers.

The functions of the portable device are controlled using the device buttons, not the buttons on the radio. The volume may be controlled using the radio or portable device.

Uconnect® 3.0 Available Media Hubs

Uconnect® 3.0	Media Hub (USB, AUX Ports)	Media Hub (SD, USB, AUX Ports)	Remote USB Port (Fully Functional)	Remote USB Port (Charging Only)	Dual Charging Ports
	S	-	-	O	O

S = Standard Equipment

O = Optional Equipment

UCONNECT® 5.0



Uconnect® 5.0

- | | |
|-------------------------|-----------------------------|
| 1 — Radio Mode | 7 — Rotate Volume Control |
| 2 — Compass Information | 8 — Rotate Tune/Scroll Knob |
| 3 — Media Mode | 9 — Mute Button |
| 4 — Access Settings | 10 — Browse/Enter Button |
| 5 — Uconnect® Phone | 11 — Screen OFF |
| 6 — More Functions | 12 — Back Function |

CAUTION!

Do NOT attach any object to the touchscreen, doing so can result in damage to the screen.

Clock Setting

To start the clock setting procedure, perform the following:

1. Push the SETTINGS button on the faceplate on the right side of the display, then press the “Clock & Date” button on the touchscreen.
2. Press the “Set Time & Format” button on the touchscreen.
3. Press the “Up” or “Down” arrows to adjust the hours or minutes, next select the “AM” or “PM” button on the touchscreen. You can also select 12hr or 24hr format by pressing the desired button on the touchscreen.
4. Once the time is set press the “Done” button on the touchscreen to exit the time screen.

Equalizer, Balance And Fade

1. Push the SETTINGS button on the faceplate on the right side of the unit.
2. Then scroll down and press the “Audio” button on the touchscreen to get to the Audio menu.
3. The Audio Menu shows the following options for you to customize your audio settings.

Equalizer

- Press the “Equalizer” button on the touchscreen to adjust the Bass, Mid and Treble. Use the “+” or “-” button on the touchscreen to adjust the equalizer to your desired settings. Press the “Done” button on the touchscreen when finished.

Balance/Fade

- Press the “Balance/Fade” button on the touchscreen to adjust the sound from the speakers. Use the “arrow” button on the touchscreen to adjust the sound level from the front and rear or right and left side speakers. Press the Center “C” button on the touchscreen to reset the balance and fade to the factory setting. Press the “Done” button on the touchscreen when finished.

Speed Adjustable

- Press the “Speed Adjusted Volume” button on the touchscreen to select between OFF, 1, 2 or 3. This will decrease the radio volume relative to a decrease in vehicle speed. Press the “Done” button on the touchscreen when finished.

Loudness

- Press the “Loudness” button on the touchscreen to select the Loudness feature. When this feature is activated it improves sound quality at lower volumes.

Radio Operation

Seek Up/Down Buttons

- Press to seek through radio stations in AM, FM or SXM bands.
- Hold either button to bypass stations without stopping.

Store Radio Presets

- When you are receiving a station that you wish to commit into memory, press and hold the desired preset button on the touchscreen for more than two seconds or until you hear a confirmation beep.
- The Radio stores up to 12 presets in each of the Radio modes. 4 presets are visible at the top of the radio screen. Pressing the “all” button on the touchscreen on the radio home screen will display all of the preset stations for that mode.

SiriusXM Premier Over 160 channels

Get every channel available on your satellite radio, and enjoy all you want, all in one place. Hear commercial-free music plus sports, news, talk and entertainment. Get all the premium programming, including Howard Stern, every NFL game, Oprah Radio®, every MLB® and NHL® game, every NASCAR® race, Martha Stewart and more. And get 20+ extra channels, including SiriusXM Latino, offering 20 channels of commercial free music, news, talk, comedy, sports and more dedicated to Spanish language programming.

To access SiriusXM Satellite Radio, press the “RADIO” button on the faceplate and then the SXM button on the touchscreen.

SiriusXM services require subscriptions, sold separately after the 12-month trial included with the new vehicle purchase. **If you decide to continue your service at the end of your trial subscription, the plan you choose will automatically renew and bill at then-current rates until you call SiriusXM at 1-866-635-2349 for U.S. residents and 1-888-539-7474 for Canadian residents to cancel. See SiriusXM Customer Agreement for complete terms at www.siriusxm.com for U.S. residents and www.siriusxm.ca for Canadian residents.** All fees and programming subject to change. Our satellite service is available only to those at least 18 and older in the 48 contiguous USA and D.C. Our Sirius satellite service is also available in PR (with coverage limitations). Our Internet radio service is available throughout our satellite service area and in AK and HI. © 2014 Sirius XM Radio Inc. Sirius, XM and all related marks and logos are trademarks of Sirius XM Radio Inc.

Disc Operation (If Equipped)

Your vehicle may have a remote CD player located in the lower center console storage bin, or in the lower center bench seat bin.

- CD/Disc Mode is entered by either inserting a CD/Disc or by pressing the MEDIA button located on the side of the display. Once in Media Mode, select “Disc.”
- Gently insert one CD into the CD player with the CD label facing as indicated on the illustration located on the Disc player.

Seek Up/Down Buttons

- Press to seek through Disc tracks.
- Hold either button to bypass tracks without stopping.

Browse

- Press the “Browse” button on the touchscreen to scroll through and select a desired track on the Disc. Press the “Exit” button on the touchscreen if you want to cancel the browse function.

USB/Audio Jack (AUX)/Bluetooth® Operation

USB/iPod®

- USB/iPod® Mode is entered by either inserting a USB Jump Drive or iPod® cable into the USB port or by pressing the MEDIA button on the faceplate located left of the display. Once in Media Mode, press the “source” button on the touchscreen and select “USB/iPod.”
- Press the MEDIA button on the faceplate, then press the “source” button on the touchscreen and then select “USB/iPod” to change the mode to the USB device if the device is connected, allowing the music from your portable device to play through the vehicle's speakers.

Audio Jack (AUX)

The AUX allows a portable device, such as an MP3 player or an iPod®, to be plugged into the radio and utilize the vehicle's audio system, using a 3.5 mm audio cable, to amplify the source and play through the vehicle speakers.

- Press the MEDIA button on the faceplate, then press the “source” button on the touchscreen and then select “AUX” to change the mode to auxiliary device if the audio jack is connected, allowing the music from your portable device to play through the vehicle's speakers.

The functions of the portable device are controlled using the device buttons, not the buttons on the radio. The volume may be controlled using the radio or portable device.

Bluetooth®

If using a Bluetooth® - equipped device, you may also be able to stream music to your vehicle's sound system.

- Press the MEDIA button on the faceplate, then press the “source” button on the touchscreen. Select “Bluetooth” to change the mode to Bluetooth® if the device is paired, allowing the music from your portable device to play through the vehicle's speakers.

Uconnect® 5.0 Available Media Hubs

Uconnect® 5.0	Media Hub (USB, AUX Ports)	Media Hub (SD, USB, AUX Ports)	Remote USB Port (Fully Functional)	Remote USB Port (Charging Only)	Dual Charging Ports
	S	-	-	S	O

S = Standard Equipment

O = Optional Equipment

Voice Text Reply (Not Compatible With iPhone®)

Once your Uconnect® system is paired with a compatible mobile device, the system can announce a new incoming text message, and read it to you over the vehicle audio system. You can reply to the message using Voice Recognition, by selecting, or saying one of the 18 pre-defined messages.

- **Here's How:** Press the Uconnect® Phone button  and wait for the beep, then say “reply.” Uconnect® will give the following prompt: “Please say the message you would like to send.” Wait for the beep and say one of the pre-defined messages. (If you are not sure, you can say “help”). Uconnect® will then read the pre-defined messages allowed. As soon as you hear the message you would like to send, you can interrupt the list of prompts by pressing the Uconnect® phone button and saying the phrase. Uconnect® will confirm the message by reading it back to you. Then press the Phone button and say “Send.”

PRE-DEFINED VOICE TEXT REPLY RESPONSES		
Yes.	Stuck in Traffic.	See you later.
No.	Start without me.	I'll be Late.
Okay.	Where are you?	I will be <number> minutes late.
Call me.	Are you there yet?	
I'll call you later.	I need directions.	See you in <number> of minutes.
I'm on my way.	Can't talk right now.	
I'm lost.		Thanks.

Voice texting reply and voice texting features require a compatible mobile device enabled with Bluetooth® Message Access Profile (MAP). iPhone® and some other smartphones do not currently support Bluetooth® MAP. U.S. residents can visit UconnectPhone.com for system and device compatibility. Canadian residents can visit UconnectPhone.com for system and device compatibility.

Want to dictate a personal message? You must first register with Uconnect® Access to take advantage of a new, cloud-based Voice Texting service, an enhancement to Voice Text Reply.

WARNING!

- Any voice commanded system should be used only in safe driving conditions following applicable laws regarding phone use. Your attention should be focused on safely operating the vehicle. Failure to do so may result in a collision causing you and others to be severely injured or killed.
- In an emergency, to use Uconnect® Phone, your mobile phone must be:
 - turned on,
 - paired to Uconnect® Phone,
 - and have network coverage.

Uconnect® 5.0 VOICE RECOGNITION QUICK TIPS

Introducing Uconnect®

Start using Uconnect® Voice Recognition with these helpful quick tips. It provides the key Voice Commands and tips you need to know to control your Uconnect® 5.0 system.

Key Features:

- 5" touchscreen
- Three buttons on either side of the display



Uconnect® 5.0

Get Started

1. U.S. residents can visit **UconnectPhone.com** to check mobile device and feature compatibility and to find phone pairing instructions.
2. Reduce background noise. Wind and passenger conversations are examples of noise that may impact recognition.
3. Speak clearly at a normal pace and volume while facing straight ahead. The microphone is positioned on the rearview mirror and aimed at the driver.
4. Each time you give a Voice Command, you must first press either the VR or Phone button, wait until **after** the beep, then say your Voice Command.
5. You can interrupt the help message or system prompts by pressing the VR or Phone button and saying a Voice Command from current category.

All you need to control your Uconnect® system with your voice are the buttons on your steering wheel.

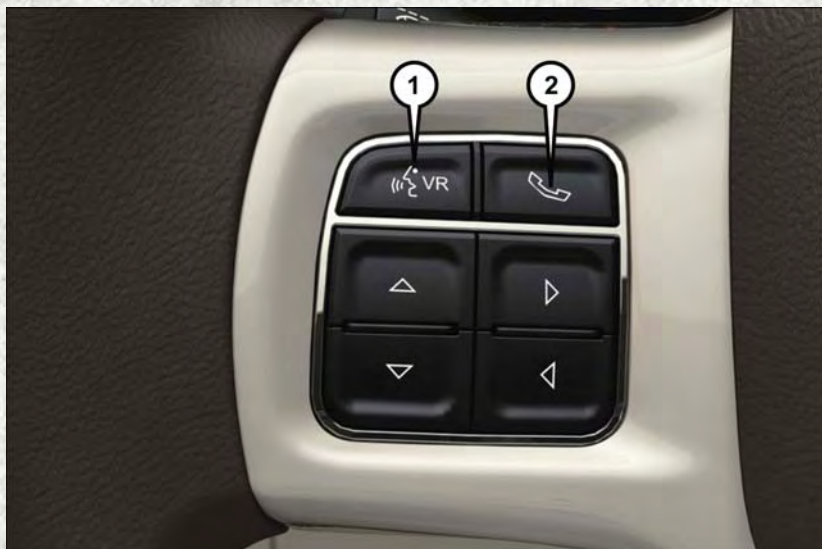

Uconnect® VR/Phone Buttons

- 1 — Push To Begin Radio or Media Functions
- 2 — Push To Initiate, Answer, Or End A Phone Call, Send Or Receive A Text

Basic Voice Commands

The basic Voice Commands below can be given at any point while using your Uconnect® system.

Push the VR button  VR . After the beep, say:

- **Cancel** to stop a current voice session
- **Help** to hear a list of suggested Voice Commands
- **Repeat** to listen to the system prompts again

Notice the visual cues that inform you of your voice recognition system's status. Cues appear on the touchscreen.

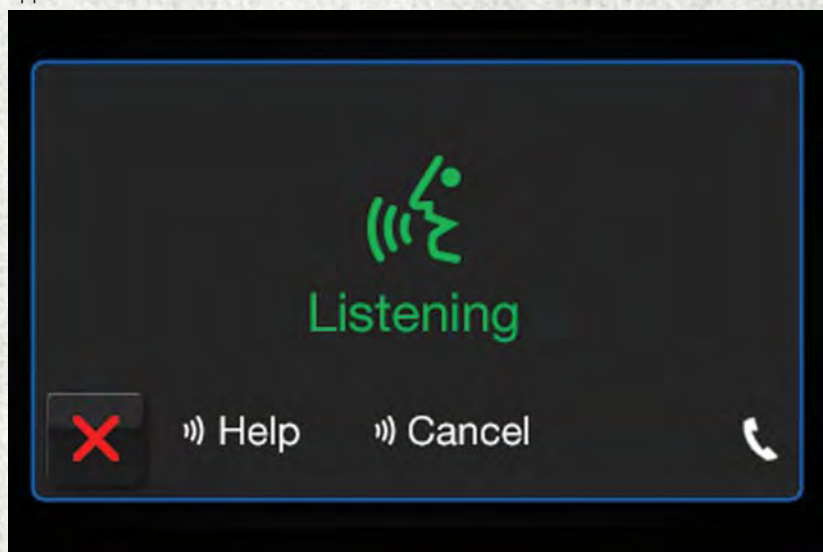

Uconnect® 5.0 Visual Cues

Radio

Use your voice to quickly get to the AM, FM or SiriusXM™ Satellite Radio® stations you would like to hear. (Subscription or included SiriusXM™ Satellite Radio trial required.)

Push the VR button  VR . After the beep, say:

- **Tune to** ninety-five-point-five FM
- **Tune to** Satellite Channel Hits 1

TIP: At any time, if you are not sure of what to say or want to learn a Voice Command, push the VR button  VR and say **“Help.”** The system will provide you with a list of commands.



Uconnect® 5.0 Radio

ELECTRONICS

Media

Uconnect® offers connections via USB, SD, Bluetooth® and auxiliary ports (If Equipped). Voice operation is only available for connected USB and iPod® devices. (Remote CD player optional and not available on all vehicles.)

Push the VR button  VR . After the beep, say one of the following commands and follow the prompts to switch your media source or choose an artist.

- **Change source** to Bluetooth®
- **Change source** to iPod®
- **Change source** to USB
- **Play artist** Beethoven; **Play album** Greatest Hits; **Play song** Moonlight Sonata; **Play genre** Classical

TIP: Press the Browse button on the touchscreen to see all of the music on your iPod® or USB device. Your Voice Command must match **exactly** how the artist, album, song and genre information is displayed.

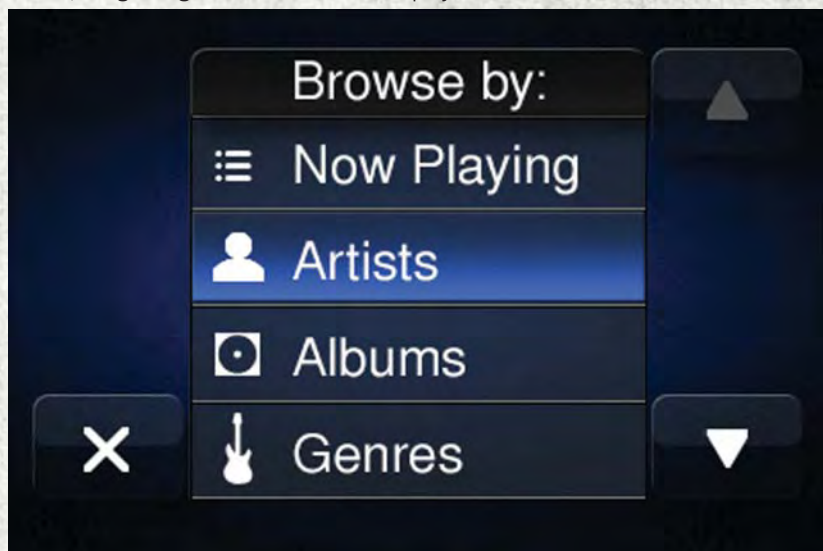

Uconnect® 5.0 Media

Phone

Making and answering hands-free phone calls is easy with Uconnect®. When the Phonebook button is illuminated on your touchscreen, your system is ready.

U.S. residents can visit UconnectPhone.com to check mobile device and feature compatibility and to find phone pairing instructions.

Push the Phone button . After the beep, say one of the following commands...

- **Call** John Smith
- **Dial** 123-456-7890 and follow the system prompts
- **Redial** (call previous outgoing phone number)
- **Call back** (call previous incoming phone number)

TIP: When providing a Voice Command, push the Phone button  and say “**Call,**” then pronounce the name **exactly** as it appears in your phone book. When a contact has multiple phone numbers, you can say “**Call John Smith work.**”



Uconnect® 5.0 Phone

Voice Text Reply

Uconnect® will announce **incoming** text messages. Push the Phone button  and say **Listen**. (Must have compatible mobile phone paired to Uconnect® system.)

1. Once an incoming text message is read to you, push the Phone button . After the beep, say: **Reply**
2. Listen to the Uconnect® prompts. After the beep, repeat one of the pre-defined messages and follow the system prompts.

TIP: Your mobile phone must have the full implementation of the **Message Access Profile (MAP)** to take advantage of this feature. For details about MAP, visit UconnectPhone.com for U.S. residents. Apple iPhone® iOS6 or later supports reading **incoming** text messages only.

PRE-DEFINED VOICE TEXT REPLY RESPONSES		
Yes.	Stuck in Traffic.	See you later.
No.	Start without me.	I'll be Late.
Okay.	Where are you?	I will be <number> minutes late.
Call me.	Are you there yet?	
I'll call you later.	I need directions.	See you in <number> of minutes.
I'm on my way.	Can't talk right now.	Thanks.
I'm lost.		

Additional Information

© 2014 Chrysler Group LLC. All rights reserved. Mopar, Mopar Owner Connect and Uconnect are registered trademarks of Chrysler Group LLC. Android is a trademark of Google Inc. SiriusXM and all related marks and logos are trademarks of SiriusXM Radio Inc. Yelp, Yelp logo, Yelp burst and related marks are registered trademarks of Yelp.

Uconnect® System Support:

- U.S. residents visit DriveUconnect.com or call: 1-877-855-8400
- Canadian residents visit DriveUconnect.ca or call: 1-800-465-2001 (English) or 1-800-387-9983 (French)

Mon. – Fri., 7:00 am – 12:00 am, ET

Sat., 8:00 am – 10:00 pm, ET

Sun., 9:00 am – 5:00 pm, ET

Uconnect® Access Services Support 1-855-792-4241. Please have your Uconnect® Security PIN ready when you call.

UCONNECT® 8.4A

Uconnect® 8.4A AT A GLANCE



Uconnect® 8.4A Radio Screen

- | | |
|----------------------------|---------------------|
| 1 — Status Bar | 5 — Climate Button |
| 2 — Menu Bar | 6 — Controls Button |
| 3 — Uconnect® Apps Button | 7 — Media Button |
| 4 — Uconnect® Phone Button | 8 — Radio Button |

Displaying The Time

- If the time is not currently displayed on the radio or player main page, press the “settings” button on the touchscreen or the “Apps” button on the touchscreen and then the “settings” button on the touchscreen. In the Settings list, press the “Clock” button on the touchscreen then press the check box next to Show Time in Status Bar.

Setting The Time

- Turn the unit on, then press the time display at the top of the screen. Press “Yes.”
- If the time is not displayed at the top of the screen, press the “Controls” button on the touchscreen, or the “Apps” button on the touchscreen, and then the “settings” button on the touchscreen. In the Settings screen, press the “Clock” button on the touchscreen, then check or uncheck this option.
- Press “+” or “-” next to Set Time Hours and Set Time Minutes to adjust the time.
- If these features are not available, uncheck the Sync with GPS box.
- Press “X” to save your settings and exit out of the Clock Setting screen.

Audio Settings

- Press the “Audio” button on the touchscreen to activate the Audio settings screen to adjust Balance\Fade, Equalizer, and Speed Adjusted Volume.
- You can return to the Radio screen by pressing the “X” located at the top right.

Balance/Fade

- Press the “Balance/Fade” button on the touchscreen to Balance the audio between the front speakers or fade the audio between the rear and front speakers.
- Pressing the “Front,” “Rear,” “Left,” or “Right” buttons on the touchscreen or press and drag the Speaker Icon to adjust the Balance/Fade.

Equalizer

- Press the “Equalizer” button on the touchscreen to activate the Equalizer screen.
- Press the “+” or “-” buttons on the touchscreen, or by pressing and dragging over the level bar for each of the equalizer bands. The level value, which spans between plus or minus 9, is displayed at the bottom of each of the Bands.

Speed Adjusted Volume

- Press the “Speed Adjusted Volume” button on the touchscreen to activate the Speed Adjusted Volume screen. The Speed Adjusted Volume is adjusted by pressing the volume level indicator. This alters the automatic adjustment of the audio volume with variation to vehicle speed.

RADIO



Uconnect® 8.4A Radio Screen

- | | |
|-------------------------------|------------------------------------|
| 1 — Radio Station Presets | 5 — Seek Down |
| 2 — Toggle Between Presets | 6 — Direct Tune To A Radio Station |
| 3 — Choose Radio Band | 7 — Seek Up |
| 4 — Browse And Manage Presets | 8 — Audio Settings |

To access the Radio mode, press the “Radio” button on the touchscreen at the lower left of the screen.

Selecting Radio Stations

- Press the desired radio band (AM, FM or SXM) button on the touchscreen.

Seek Up/Seek Down

- Press the Seek arrow buttons on the touchscreen for less than two seconds to seek through radio stations.
- Press and hold either arrow button on the touchscreen for more than two seconds to bypass stations without stopping. The radio will stop at the next listenable station once the arrow button on the touchscreen is released.

Direct Tune

- Tune directly to a radio station by pressing the “Tune” button on the touchscreen on the screen, and entering the desired station number.

Store Radio Presets

Your radio can store 36 total preset stations, 12 presets per band (AM, FM and SXM). They are shown at the top of your radio screen. To see the 12 preset stations per band, press the arrow button on the touchscreen at the top right of the screen to toggle between the two sets of six presets.

- To set a station into memory press and hold the desired numbered button on the touchscreen for more than two seconds or until you hear a confirmation beep.

SiriusXM PREMIER OVER 160 CHANNELS

Get every channel available on your satellite radio, and enjoy all you want, all in one place. Hear commercial-free music plus sports, news, talk and entertainment. Get all the premium programming, including Howard Stern, every NFL game, Oprah Radio®, every MLB® and NHL® game, every NASCAR® race, Martha Stewart and more. And get 20+ extra channels, including SiriusXM Latino, offering 20 channels of commercial free music, news, talk, comedy, sports and more dedicated to Spanish language programming.

- To access SiriusXM Satellite Radio, press the “SXM” button on the touchscreen on the main Radio screen.

The following describes features that are available when in SiriusXM Satellite Radio mode:

Seek Up/Seek Down

- Press the Seek arrow buttons on the touchscreen for less than two seconds to seek through channels in SXM mode.
- Press and hold either arrow button on the touchscreen for more than two seconds to bypass channels without stopping. The radio will stop at the next listenable channel once the arrow button on the touchscreen is released.

Direct Tune

- Tune directly to a SXM channel by pressing the “Tune” button on the touchscreen on the screen, and entering the desired station number.

Jump

- Automatically tells you when Traffic & Weather for a favorite city is available, and gives you the option to switch to that channel. Press “Jump” to activate the feature. After listening to Traffic and Weather, press “Jump” again to return to the previous channel.

Fav

- Activates the favorites menu. You can add up to 50 favorite artists or songs. Just press “Add Fav Artist” or “Add Fav Song” while the song is playing. You will then be alerted any time one of these songs, or works by these artists, is playing on other SiriusXM channels.

SiriusXM Parental Controls

- You can skip or hide certain channels from view if you do not want access to them. Press the “Apps” button on the touchscreen, then the “Settings” button on the touchscreen, next press the “Sirius Setup” button on the touchscreen, then select Channel Skip. Press the box check-mark next to the channel you want skipped. They will not show up in normal usage.
- SiriusXM also offers the option to permanently block selected channels. Call (1-888-601-6297 for U.S. customers, 1-877-438-9677 for Canadian customers) and request the Family-Friendly Package.

Browse

Lets you browse the SiriusXM channel listing or Genre listing. Favorites, Game Zone, Weather and Jump settings also provide a way to browse the SiriusXM channel list.

Browse Sub-Menu	Sub-Menu Description
All	Shows the channel listing.
Genre	Provides a list of all genres, and lets you jump to a channel within the selected genre.
Presets	Lets you scroll the list of Preset satellite channels. Press the channel, or press Enter on the Tune knob, to go to that channel. Press the trash can icon to delete a preset. Your presets are also shown at the top of the main Satellite Radio screen.
Favorites	Lets you manage artists and songs in the Favorites list and configure Alert Settings to let you know when favorite songs or artists are playing on other channels. Also, view a list of channels airing any of your Favorites.
Game Zone	Provides alerts when your favorite sports teams are starting a game which is being aired on other SiriusXM channels, or when their game score is announced. You can select and manage your Teams list here, and configure alerts.
Jump	Lets you select your favorite cities for Traffic & Weather information, which is used by the Jump feature on the main satellite radio screen.

Replay

Lets you replay up to 44 minutes of the content of the current SiriusXM channel.

Replay Option	Option Description
Play/Pause	Press to Pause content playback. Press Pause/Play again to resume playback.
Rewind/RW	Rewinds the channel content in steps of five seconds. Press and hold to rewind continuously, then release to begin playing content at that point.
Fast Forward/FW	Forwards the content, and works similarly to Rewind/RW. However, Fast Forward/FW can only be used when content has been previously rewind.

Replay Option	Option Description
Replay Time	Displays the amount of time in the upper center of the screen by which your content lags the Live channel.
Live	Resumes playback of Live content at any time while replaying rewind content.

- SiriusXM services require subscriptions, sold separately after the 12-month trial included with the new vehicle purchase. **If you decide to continue your service at the end of your trial subscription, the plan you choose will automatically renew and bill at then-current rates until you call SiriusXM at 1-866-635-2349 for U.S. residents and 1-888-539-7474 for Canadian residents to cancel. See SiriusXM Customer Agreement for complete terms at www.siriusxm.com (US residents) or siriusxm.ca (Canadian residents).** All fees and programming subject to change. Our satellite service is available only to those at least 18 and older in the 48 contiguous USA and D.C. Our Sirius satellite service is also available in PR (with coverage limitations). Our Internet radio service is available throughout our satellite service area and in AK and HI. ©2014 Sirius XM Radio Inc. Sirius, XM and all related marks and logos are trademarks of Sirius XM Radio Inc.

Disc Operation (If Equipped)

- Your vehicle may have a remote CD player located in the lower center console storage bin, or in the lower center bench seat bin.
- CD/Disc Mode is entered by either inserting a CD/Disc or by pressing the MEDIA button located on the side of the display. Once in Media Mode, select “Disc.”
- Gently insert one CD into the CD player with the CD label facing as indicated on the illustration located on the Disc player.

Seek Up/Down Buttons

- Press to seek through Disc tracks.
- Hold either button to bypass tracks without stopping.

Browse

- Press the “Browse” button on the touchscreen to scroll through and select a desired track on the Disc. Press the “Exit” button on the touchscreen if you wish to cancel the browse function.

MEDIA HUB — PLAYING iPod®/USB/MP3 DEVICES

There are many ways to play music from iPod®/MP3 players or USB devices through your vehicle's sound system. Press your "Media" button on the touchscreen to begin.



Uconnect® 8.4A Media Hub

1 — USB Charge Only Port
2 — SD Card Port

3 — USB Port
4 — Audio/AUX Jack

Audio Jack (AUX)

The AUX allows a portable device, such as an MP3 player or an iPod®, to be plugged into the radio and utilize the vehicle's sound system, using a 3.5 mm audio cable, to amplify the source and play through the vehicle speakers.

Pressing the "AUX" button on the touchscreen will change the mode to auxiliary device if the audio jack is connected, allowing the music from your portable device to be heard through the vehicle's speakers. In order to activate the AUX, plug in the audio jack.

The functions of the portable device are controlled using the device buttons. The volume may be controlled using the radio or portable device.

To route the audio cable out of the center console, use the access cut out in the front of the console.

USB Port

Connect your iPod® or compatible device using a USB cable into the USB Port. USB Memory sticks with audio files can also be used. Audio from the device can be played on the vehicles sound system while providing metadata (artist, track title, album, etc.) information on the radio display.

When connected, the iPod®/compatible USB device can be controlled using the radio or Steering Wheel Audio Controls to play, skip to the next or previous track, browse, and list the contents.

The iPod® battery charges when plugged into the USB port (if supported by the specific device).

To route the USB/iPod® cable out of the center console, use the access cut out.

NOTE:

When connecting your iPod® device for the first time, the system may take several minutes to read your music, depending on the number of files. For example, the system will take approximately five minutes for every 1000 songs loaded on the device. Also during the reading process, the Shuffle and Browse functions will be disabled. This process is needed to ensure the full use of your iPod® features and only happens the first time it is connected. After the first time, the reading process of your iPod® will take considerably less time unless changes are made or new songs are added to the playlist.

The USB port supports certain Mini, Classic, Nano, Touch, and iPhone® devices. The USB port also supports playing music from compatible external USB Mass Storage Class memory devices. Some iPod® software versions may not fully support the USB port features. Please visit Apple's website for iPod® software updates.

SD Card

Play songs stored on an SD card inserted into the SD card slot.

Song playback can be controlled using the radio or Steering Wheel Audio Controls to play, skip to the next or previous track, browse, and list the contents.

Bluetooth® Streaming Audio

If equipped with Uconnect® Voice Command, your Bluetooth-equipped iPod® devices, cell phones or other media players, may also be able to stream music to your vehicle's sound system. Your connected device must be Bluetooth-compatible, and paired with your system (see Uconnect® Phone for pairing instructions). You can access the music from your connected Bluetooth® device by pressing the Bluetooth® button on the touchscreen while in Media mode.

Uconnect® 8.4A & 8.4AN Available Media Hubs

Uconnect® 8.4A & 8.4AN	Media Hub (USB, AUX Ports)	Media Hub (SD, USB, AUX Ports)	Remote USB Port (Fully Functional)	Remote USB Port (Charg- ing Only)	Dual Charging Ports
	-	S	S	O	O

S = Standard Equipment

O = Optional Equipment

iPod®/CD/AUX CONTROLS



iPod®/CD/AUX Controls

- | | |
|--------------------------|--|
| 1 — Repeat Music Track | 5 — Music Track Information |
| 2 — Music Track And Time | 6 — Show Songs Currently In Cue To Be Played |
| 3 — Shuffle Music Tracks | 7 — Browse Music By |
| 4 — Music Source | |

The iPod®/CD/AUX controls are accessed by pressing the desired button on the touchscreen displayed on the side of the screen and choosing between Disc, AUX, iPod®, Bluetooth or SD Card.

NOTE:

Uconnect® will usually automatically switch to the appropriate mode when something is first connected or inserted into the system.

NAVIGATION (DEALER-ACTIVATED OPTION)

- Your Uconnect® 8.4A is “Navigation-Ready,” and can be equipped with Navigation at an extra cost. Please see your dealer for details.
- The information in the section below is only applicable if the Navigation has been activated.

Changing The Navigation Voice Prompt Volume

1. Press the “settings” button on the touchscreen.
2. In the Settings menu, press the “Guidance” button on the touchscreen.
3. In the Guidance menu, adjust the Nav Volume by pressing the “+” or “-” Nav Volume Adjustment button on the touchscreens.



Uconnect® 8.4 Navigation

- 1 — Find A Destination
- 2 — View Map
- 3 — Information
- 4 — Emergency

- 5 — Navigation Settings
- 6 — Stop A Route
- 7 — Detour A Route
- 8 — Repeat Route Guidance Prompt

Finding Points Of Interest (POI)

- From the main Navigation menu, press the “Where To?” button on the touchscreen, then press the “Points of Interest” button on the touchscreen.
- Select a Category and then a subcategory, if necessary.
- Select your destination and press the “Yes” button on the touchscreen.

Finding A Place By Spelling The Name

- From the Main Navigation Menu press the “Where to?” button on the touchscreen, press the “Points of Interest” button on the touchscreen and then press the “Spell Name” button on the touchscreen.
- Enter the name of your destination.
- Press the “List” button on the touchscreen.
- Select your destination and press the “Yes” button on the touchscreen.

Entering A Destination Address

- From the main Navigation menu press the “Where To?” button on the touchscreen, then press the “Address” button on the touchscreen.
- Follow the on-screen prompts (country, state/province, city, street) to enter the address and press the “Yes” button on the touchscreen.
- Destination entry is not available while your vehicle is in motion. However, you can also use Voice Command to enter an address while moving. See Voice Command Tips for more information.

Setting Your Home Location

- Press the “Nav” button on the touchscreen in the menu bar to access the Navigation system and the Main Navigation menu.
- Press the “Where To?” button on the touchscreen, then press the “Go Home” button on the touchscreen.
- You may enter your address directly, use your current location as your home address, or choose from recently found locations.
- To delete your Home location (or other saved locations) so you can save a new Home location, press the “Where To?” button on the touchscreen from the Main Navigation menu, then press the “Go Home” button on the touchscreen, and in the Yes screen press the “Options” button on the touchscreen. In the Options menu press “Clear Home.” Set a new Home location by following the previous instructions.

ELECTRONICS

Go Home

- A Home location must be saved in the system. From the Main Navigation menu, press the “Where To?” button on the touchscreen, then press the “Go Home” button on the touchscreen.



Uconnect® 8.4 Map

- | | |
|-------------------------------|--------------------------------|
| 1 — Distance To Next Turn | 5 — Your Location On The Map |
| 2 — Next Turn Street | 6 — Navigation Main Menu |
| 3 — Estimated Time Of Arrival | 7 — Current Street Location |
| 4 — Zoom In And Out | 8 — Navigation Routing Options |

Your route is marked with a blue line on the map. If you depart from the original route, your route is recalculated. A speed limit icon could appear as you travel on major roadways.

Adding A Stop

- To add a stop you must be navigating a route.
- Press the “Menu” button on the touchscreen to return to the Main Navigation menu.
- Press the “Where To?” button on the touchscreen, then search for the extra stop. When another location has been selected, you can choose to cancel your previous route, add as the first destination or add as the last destination.
- Press the desired selection and press the “Yes” button on the touchscreen.

Taking A Detour

- To take a detour you must be navigating a route.
- Press the “Detour” button on the touchscreen.

NOTE:

If the route you are currently taking is the only reasonable option, the device might not calculate a detour.

- For more information, see your Uconnect® Supplement Manual.

Uconnect® Phone (Bluetooth® HANDS FREE CALLING)

- If the Uconnect® Phone Button  exists on your steering wheel, then you have the Uconnect® Phone features.
- The Uconnect® Phone is a voice-activated, hands-free, in-vehicle communications system with Voice Command Capability (see Voice Command section).
- The Uconnect® Phone allows you to dial a phone number with your mobile phone using simple voice commands or pressing the buttons on the touchscreen.
- Refer to the Understand The Features Of Your Vehicle section of your vehicle's Owner's Manual on the DVD for further details.

NOTE:

The Uconnect® Phone requires a mobile phone equipped with the Bluetooth® Hands-Free Profile, Version 1.0 or higher. For Uconnect® Customer Support: U.S. residents visit UconnectPhone.com or call 1-877-855-8400. Canadian Residents – visit UconnectPhone.com or call, 1-800-465-2001 (English) or 1-800-387-9983 (French).

Pairing A Phone

- To use the Uconnect® Phone feature, you must first pair your Bluetooth® phone with the Uconnect® system.

Start Pairing Procedure On The Radio

- Press the “Phone” button on the touchscreen and then the “settings” button on the touchscreen. Next, press “Add Device.”
- Uconnect® Phone will display an “In progress” screen while the system is connecting.

Start Pairing Procedure On Mobile Phone

- Search for available devices on your Bluetooth® enabled mobile phone. This is usually within Settings or Options under “Bluetooth.” See your mobile phone's manual for details.
- When your phone finds the system, select “Uconnect” as the paired device. You may be prompted by your phone to download the phonebook. This is so you can make calls by saying the name of your contact (PBAP-Phone Book Access Profile).

Complete The Pairing Procedure

- When prompted on the phone, verify with the radio password shown on the Uconnect® Screen.
- If your phone asks you to accept a connection request from Uconnect®, select “Yes.” If available, check the box telling it not to ask again – that way your phone will automatically connect each time you start the vehicle.

Select The Mobile Phone's Priority Level

- When the pairing process has successfully completed, the system will prompt you to choose whether or not this is your favorite phone. Selecting “Yes” will make this phone the highest priority. This phone will take precedence over other paired phones within range. Only one phone can be paired at a time.
- You are now ready to make hands-free calls. Press the Uconnect® Phone button on your steering wheel to begin.

Making A Phone Call



To begin a phone call using Uconnect® Voice Command:

- Push the Uconnect® Phone button .
- After the BEEP, say “dial” then the number (or “call” then the name as listed in your phone; see Phonebook).

NOTE:

You can also initiate a call by using the touchscreen on the Phone main screen.

Receiving A Call — Accept (And End)

- When an incoming call rings/is announced on Uconnect®, push the Phone button .
- To end a call, push the Phone button .

Mute (Or Unmute) Microphone During Call

- During a call, press the “mute” button on the touchscreen to mute and unmute the call.

Transfer Ongoing Call Between Handset And Vehicle

During an on-going call, press the “Transfer” button on the touchscreen to transfer an on-going call between handset and vehicle.

Common Phone Commands (Examples)

- “Call John Smith”
- “Call John Smith mobile”
- “Dial 1 248 555 1212”
- “Call Emergency”
- “Call Towing Assistance”
- “Redial”



Phonebook

- Uconnect® radios will automatically download your phonebook from your paired phone, if this feature is supported by your phone. Entries are updated each time that the phone is connected. If your phone book entries do not appear, check the settings on your phone. Some phones require you to enable this feature manually.
- Your phonebook can be browsed on your radio screen, but editing can only be done on your phone. To browse, press the “Phone” button on the touchscreen, then the “Phonebook” button on the touchscreen.
- Favorite phonebook entries can be saved as Favorites for quicker access. Favorites are shown at the top of your main phone screen.

Changing The Volume

- Start a dialogue by pressing the Phone button , then say a command for example - "Help".
- Use the radio VOLUME/MUTE rotary knob to adjust the volume to a comfortable level while the Uconnect® system is speaking. Please note the volume setting for Uconnect® is different than the audio system.

NOTE:

To access help, press the Uconnect® Phone  button on the steering wheel and say "help." Touch the display or push either  or  VR button and say "cancel" to cancel the help session.

Voice Text Reply (Not Compatible With iPhone®)

Once your Uconnect® system is paired with a compatible mobile device, the system can announce a new incoming text message, and read it to you over the vehicle audio system. You can reply to the message using Voice Recognition, by selecting, or saying one of the 18 pre-defined messages.

- **Here's How:** Press the Uconnect® Phone button  and wait for the beep, then say "reply." Uconnect® will give the following prompt: "Please say the message you would like to send." Wait for the beep and say one of the pre-defined messages. (If you are not sure, you can say "help"). Uconnect® will then read the pre-defined messages allowed. As soon as you hear the message you would like to send, you can interrupt the list of prompts by pressing the Uconnect® phone button and saying the phrase. Uconnect® will confirm the message by reading it back to you. Then press the Phone button and say "Send."

PRE-DEFINED VOICE TEXT REPLY RESPONSES		
Yes.	Stuck in Traffic.	See you later.
No.	Start without me.	I'll be Late.
Okay.	Where are you?	I will be <number> minutes late.
Call me.	Are you there yet?	
I'll call you later.	I need directions.	See you in <number> of minutes.
I'm on my way.	Can't talk right now.	Thanks.
I'm lost.		

Voice texting reply and voice texting features require a compatible mobile device enabled with Bluetooth® Message Access Profile (MAP). iPhone® and some other smartphones do not currently support Bluetooth® MAP. U.S. residents can visit UconnectPhone.com for system and device compatibility. Canadian residents can visit UconnectPhone.com for system and device compatibility.

Want to dictate a personal message? You must first register with Uconnect® Access to take advantage of a new, cloud-based Voice Texting service, an enhancement to Voice Text Reply.

WARNING!

- Any voice commanded system should be used only in safe driving conditions following applicable laws regarding phone use. Your attention should be focused on safely operating the vehicle. Failure to do so may result in a collision causing you and others to be severely injured or killed.
- In an emergency, to use Uconnect® Phone, your mobile phone must be:
 - turned on,
 - paired to Uconnect® Phone,
 - and have network coverage.

Uconnect® 8.4A/8.4AN VOICE RECOGNITION QUICK TIPS

Introducing Uconnect®

Start using Uconnect® Voice Recognition with these helpful quick tips. It provides the key Voice Commands and tips you need to know to control your Uconnect® 8.4AN system.

If you see the  icon on your touchscreen, you have the Uconnect® 8.4AN system. If not, you have a Uconnect® 8.4A system.



Uconnect® 8.4AN

ELECTRONICS

Get Started

1. U.S. residents can visit **UconnectPhone.com** to check mobile device and feature compatibility and to find phone pairing instructions.
2. Reduce background noise. Wind and passenger conversations are examples of noise that may impact recognition.
3. Speak clearly at a normal pace and volume while facing straight ahead. The microphone is positioned on the rearview mirror and aimed at the driver.
4. Each time you give a Voice Command, you must first push either the VR or Phone button, wait until **after** the beep, then say your Voice Command.
5. You can interrupt the help message or system prompts by pushing the VR or Phone button and saying a Voice Command from current category.

All you need to control your Uconnect® system with your voice are the buttons on your steering wheel.

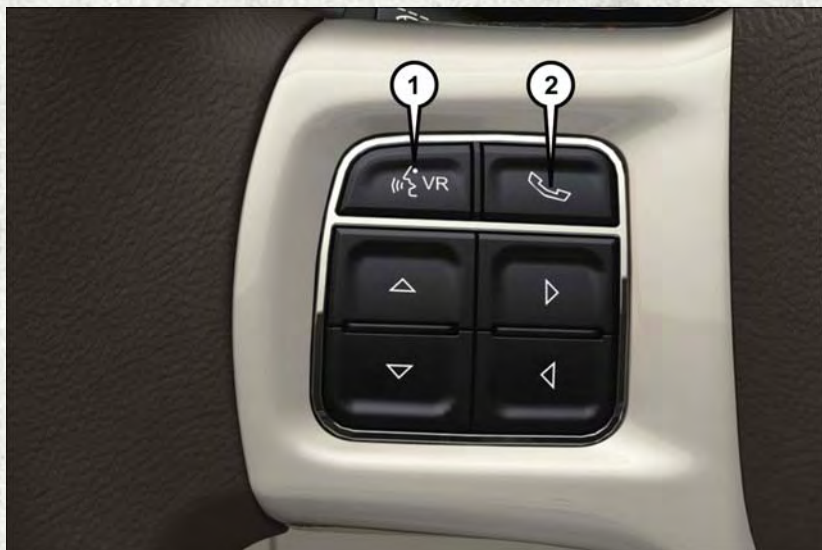

Uconnect® VR/Phone Buttons

- 1 — Push To Begin Radio, Media, Navigation, Apps And Climate Functions
2 — Push To Initiate Or To Answer A Phone Call, Send Or Receive A Text
-

Basic Voice Commands

The basic Voice Commands below can be given at any point while using your Uconnect® system.

Push the VR button  VR . After the beep, say:

- **Cancel** to stop a current voice session
- **Help** to hear a list of suggested Voice Commands
- **Repeat** to listen to the system prompts again

Notice the visual cues that inform you of your voice recognition system's status. Cues appear on the touchscreen.



Uconnect® 8.4A/8.4AN

ELECTRONICS

Radio

Use your voice to quickly get to the AM, FM or SiriusXM™ Satellite Radio® stations you would like to hear. (Subscription or included SiriusXM™ Satellite Radio trial required.)

Push the VR button  VR . After the beep, say:

- **Tune to** ninety-five-point-five FM
- **Tune to** Satellite Channel Hits 1

TIP: At any time, if you are not sure of what to say or want to learn a Voice Command, push the VR button  VR and say **“Help.”** The system will provide you with a list of commands.

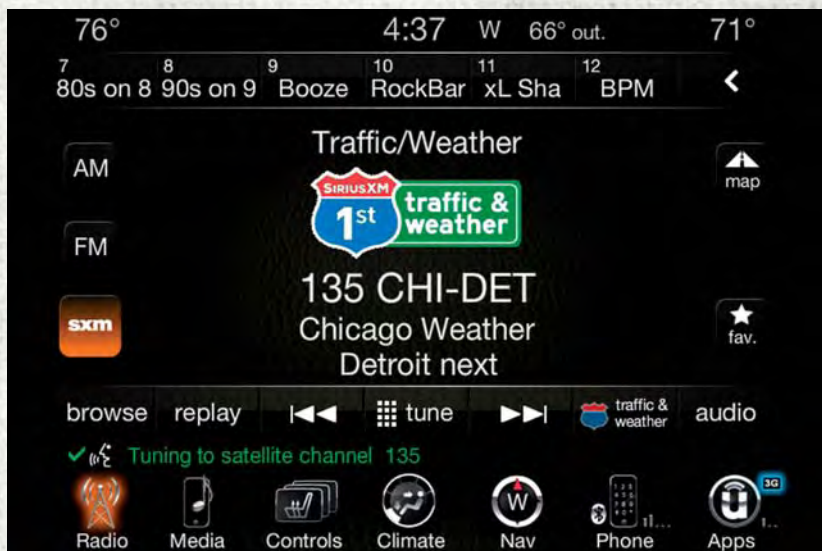

Uconnect® 8.4A/8.4AN Radio

Media

Uconnect® offers connections via USB, SD, Bluetooth® and auxiliary ports (If Equipped). Voice operation is only available for connected USB and iPod® devices. (Remote CD player optional and not available on all vehicles.)

Push the VR button  VR . After the beep, say one of the following commands and follow the prompts to switch your media source or choose an artist.

- **Change source** to Bluetooth®
- **Change source** to iPod®
- **Change source** to USB
- **Play artist** Beethoven; **Play album** Greatest Hits; **Play song** Moonlight Sonata; **Play genre** Classical

TIP: Press the Browse button on the touchscreen to see all of the music on your iPod® or USB device. Your Voice Command must match **exactly** how the artist, album, song and genre information is displayed.



Uconnect® 8.4A/8.4AN Media

ELECTRONICS

Phone

Making and answering hands-free phone calls is easy with Uconnect®. When the Phonebook button is illuminated on your touchscreen, your system is ready.

U.S. residents can visit:

- UconnectPhone.com for mobile phone compatibility and pairing instructions.

Canadian residents can visit:

- UconnectPhone.com for mobile phone compatibility and pairing instructions.

Push the Phone button . After the beep, say one of the following commands...

- **Call** John Smith
- **Dial** 123-456-7890 and follow the system prompts
- **Redial** (call previous outgoing phone number)
- **Call back** (call previous incoming phone number)

TIP: When providing a Voice Command, push the Phone button  and say “Call,” then pronounce the name **exactly** as it appears in your phone book. When a contact has multiple phone numbers, you can say “Call John Smith **work**.”



Uconnect® 8.4A/8.4AN Phone

Voice Text Reply

Uconnect® will announce **incoming** text messages. Push the Phone button  and say **Listen**. (Must have compatible mobile phone paired to Uconnect® system.)

1. Once an incoming text message is read to you, push the Phone button . After the beep, say: **Reply**
2. Listen to the Uconnect® prompts. After the beep, repeat one of the pre-defined messages and follow the system prompts.

TIP: Your mobile phone must have the full implementation of the **Message Access Profile (MAP)** to take advantage of this feature. For details about MAP, visit UconnectPhone.com for U.S. residents. Apple iPhone® iOS6 or later supports reading **incoming** text messages only.

PRE-DEFINED VOICE TEXT REPLY RESPONSES		
Yes.	Stuck in Traffic.	See you later.
No.	Start without me.	I'll be Late.
Okay.	Where are you?	I will be <number> minutes late.
Call me.	Are you there yet?	
I'll call you later.	I need directions.	See you in <number> of minutes.
I'm on my way.	Can't talk right now.	Thanks.
I'm lost.		

ELECTRONICS

Climate (8.4A/8.4AN)

Too hot? Too cold? Adjust vehicle temperatures hands-free and keep everyone comfortable while you keep moving ahead. (If vehicle is equipped with climate control.)

Push the VR button  VR . After the beep, say one of the following commands:

- **Set driver temperature to 70 degrees**
- **Set passenger temperature to 70 degrees**
- **Set both temperatures to 70 degrees**

TIP: Voice Command for Climate may only be used to adjust the interior temperature of your vehicle. Voice Command will not work to adjust the heated seats or steering wheel (if equipped).



Uconnect® 8.4A/8.4AN Climate

Navigation (8.4A/8.4AN)

The Uconnect® navigation feature helps you save time and become more productive when you know exactly how to get to where you want to go. (Navigation is optional on the Uconnect® 8.4A system. See your dealer to activate navigation at any time.)

- To enter a destination, push the VR button  VR . After the beep, say:
 - For the 8.4A Uconnect® System, say: **Enter state**.
 - For the 8.4AN Uconnect® System, say: **Navigate to 800 Chrysler Drive Auburn Hills, Michigan**.
- Then follow the system prompts.

TIP: To start a POI search, push the VR button  VR . After the beep, say “**Find nearest coffee shop**.”



Uconnect® 8.4A/8.4AN Navigation

Uconnect® Access — If Equipped (8.4A/8.4AN)

An included trial and/or subscription is required to take advantage of the Uconnect® Access services in the next section of this guide. To register with Uconnect® Access, press the “Apps” button on the 8.4-inch touchscreen to get started. Detailed registration instructions can be found on the next page.

*Uconnect® Access is available only on equipped vehicles purchased within the continental United States, Alaska and Hawaii. Services can only be used where coverage is available; see coverage map for details.

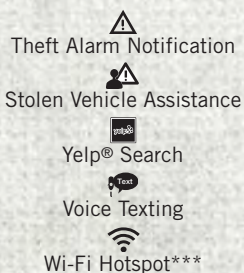
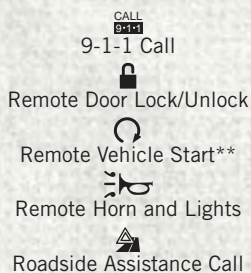

**If vehicle is equipped.

***Extra charges apply.

Register (8.4A/8.4AN)

1. Press the **"Apps"** button on the bottom of the 8.4-inch touchscreen.
2. If a pop-up message appears, press **"Register"** or go to the **"Favorite Apps"** or **"All Apps"** menu and press **"Uconnect® Registration."**
3. Read through the registration instructions. Enter and confirm your personal email address. Then press **"Send."**
4. Check your personal inbox for an email from Uconnect® Access.
5. Click on the link inside the email within **72 hours** and complete the easy online registration process to create a personal Mopar® Owner Connect account linked to your vehicle.



Uconnect® 8.4AN Registration

Mobile App (8.4A/8.4AN)

Securely link your mobile device to your vehicle with the Uconnect® Access App. Once you have downloaded the App, you may start your vehicle or lock it from virtually any distance. (Vehicle must be properly equipped with factory-installed Remote Start.)

Download the Uconnect® Access App to compatible Apple® or Android® mobile devices. All you need to do is:

1. After registering with Uconnect® Access, log on to your Mopar® Owner Connect account at moparownerconnect.com.
2. On the Dashboard page, enter your mobile phone number to receive a link to download the App on your mobile device. Or, go to iTunes® or Google Play and search for the Uconnect® Access App.
3. To activate the App, enter your Mopar Owner Connect user name and password and log in. Your vehicle is then connected to your mobile device.



Mobile App

Voice Texting (8.4A/8.4AN)

You must be registered with Uconnect® Access and have a compatible MAP – enabled smartphone to use your voice to send a personalized text message. (Not compatible with iPhone®.)

1. To send a message, push the Phone button  VR. After the beep, say: **“Send message to John Smith.”**



2. Listen to the prompt. After the beep, dictate the message you would like to send. Wait for Uconnect® to process your message.
3. The Uconnect® system will repeat your message and provide a variety of options to add to, delete, send or hear the message again. After the beep, tell Uconnect® what you'd like to do. For instance, if you're happy with your message, after the beep, say **"Send."**

TIP:

- Messages are limited to 140 characters.
- The Messaging button on the touchscreen must be illuminated to use the feature.

Yelp® (8.4A/8.4AN)

Once registered with Uconnect® Access, you can use your voice to search for the most popular places or things around you.

1. Push the VR button  VR . After the beep, say: **Launch YELP®**
2. Once the YELP® home screen appears on the touchscreen, push the VR button  VR , then say: **YELP® search**
3. Listen to the system prompts and after the beep, tell Uconnect® the place or business that you'd like Uconnect® to find.

TIP: Once you perform a search, you can reorganize the results by selecting either the Best Match, Rating or Distance tab on the top of the touchscreen display.



Yelp®

SiriusXM Travel Link™ (8.4A/8.4AN — US Market Only)

Need to find a gas station, view local movie listings, check a sports score or the 5 - day weather forecast? SiriusXM Travel Link™ is a suite of services that brings a wealth of information right to your Uconnect® 8.4AN system. (Not available for 8.4A system.)

Push the VR button  VR . After the beep, say one of the following commands:

- **Show fuel prices**
- **Show 5 - day weather forecast**
- **Show extended weather**

TIP: Traffic alerts are not accessible with Voice Command.



SiriusXM Travel Link™

Additional Information

© 2014 Chrysler Group LLC. All rights reserved. Mopar, Mopar Owner Connect and Uconnect are registered trademarks of Chrysler Group LLC. Android is a trademark of Google Inc. SiriusXM and all related marks and logos are trademarks of SiriusXM Radio Inc. Yelp, Yelp logo, Yelp burst and related marks are registered trademarks of Yelp.

Uconnect® System Support:

- U.S residents visit DriveUconnect.com or call: 1-877-855-8400
- Canadian residents visit DriveUconnect.ca or call: 1-800-465-2001 (English) or 1-800-387-9983 (French)

Mon. – Fri., 7:00 am – 12:00 am, ET

Sat., 8:00 am – 10:00 pm, ET

Sun., 9:00 am – 5:00 pm, ET

Uconnect® Access Services Support 1-855-792-4241. Please have your Uconnect® Security PIN ready when you call.

UCONNECT® 8.4AN

Uconnect® 8.4AN AT A GLANCE



Uconnect® 8.4AN Radio Screen

- | | |
|-------------------------------|---------------------------------|
| 1 — Status Bar | 6 — Uconnect® Navigation Button |
| 2 — View Small Navigation Map | 7 — Climate Button |
| 3 — HD Radio Available | 8 — Controls Button |
| 4 — Uconnect® Apps Button | 9 — Media Button |
| 5 — Uconnect® Phone Button | 10 — Radio Button |

Displaying The Time

- If the time is not currently displayed on the radio or player main page, press the “Controls” button on the touchscreen or the “Apps” button on the touchscreen and then the “settings” button on the touchscreen. In the Settings list, press the “Clock” button on the touchscreen then press the check box next to Sync Time.

Setting The Time

- Model 8.4AN synchronizes time automatically via GPS, so it should not require any time adjustment. If you do need to set the time manually, follow the instructions below for Model 8.4A.
- For Model 8.4A, turn the unit on, then press the time display at the top of the screen. Press “Yes.”
- If the time is not displayed at the top of the screen, press the “Controls” button on the touchscreen or the “Apps” button on the touchscreen and then the “settings” button on the touchscreen. In the Settings screen, press the “Clock” button on the touchscreen, then check or uncheck this option.
- Press “+” or “-” next to Set Time Hours and Set Time Minutes to adjust the time.
- If these features are not available, uncheck the Sync Time box.
- Press “X” to save your settings and exit out of the Clock Setting screen.

Audio Settings

- Press of the “Audio” button on the touchscreen to activate the Audio settings screen to adjust Balance\Fade, Equalizer, and Speed Adjusted Volume.
- You can return to the Radio screen by pressing the “X” located at the top right.

Balance/Fade

- Press the “Balance/Fade” button on the touchscreen to Balance audio between the front speakers or fade the audio between the rear and front speakers.
- Pressing the “Front,” “Rear,” “Left,” or “Right” buttons on the touchscreen or press and drag the Speaker Icon to adjust the Balance/Fade.

Equalizer

- Press the “Equalizer” button on the touchscreen to activate the Equalizer screen.
- Press the “+” or “-” buttons on the touchscreen, or press and drag over the level bar for each of the equalizer bands. The level value, which spans between plus or minus 9, is displayed at the bottom of each of the Bands.

Speed Adjusted Volume

- Press the “Speed Adjusted Volume” button on the touchscreen to activate the Speed Adjusted Volume screen. The Speed Adjusted Volume is adjusted by pressing the volume level indicator. This alters the automatic adjustment of the audio volume with variation to vehicle speed.

RADIO



Uconnect® 8.4AN Radio

- | | |
|-------------------------------|------------------------------------|
| 1 — Radio Station Presets | 6 — Seek Down |
| 2 — Toggle Between Presets | 7 — Direct Tune To A Radio Station |
| 3 — Choose Radio Band | 8 — Seek Up |
| 4 — HD Radio Available | 9 — Audio Settings |
| 5 — Browse And Manage Presets | |

- To access the Radio mode, press the “Radio” button on the touchscreen at the lower left of the screen.

Selecting Radio Stations

- Press the desired radio band (AM, FM or SXM) button on the touchscreen.

Seek Up/Seek Down

- Press the Seek arrow buttons on the touchscreen for less than two seconds to seek through radio stations.
- Press and hold either arrow button on the touchscreen for more than two seconds to bypass stations without stopping. The radio will stop at the next listenable station once the arrow button on the touchscreen is released.

Direct Tune

- Tune directly to a radio station by pressing the “Tune” button on the screen, and entering the desired station number.

Store Radio Presets

- Your radio can store 36 total preset stations, 12 presets per band (AM, FM and SXM). They are shown at the top of your radio screen. To see the 12 preset stations per band, press the arrow button on the touchscreen at the top right of the screen to toggle between the two sets of six presets.
- To set a station into memory press and hold the desired numbered button on the touchscreen for more than two seconds or until you hear a confirmation beep.

HD Radio (US RESIDENTS ONLY)

- HD Radio (available on Uconnect 8.4AN) operates similar to conventional radio except it allows broadcasters to transmit a high-quality digital signal.
- With an HD radio receiver, the listener is provided with a clear sound that enhances the listening experience. HD radio can also transmit data such as song title or artist.

SiriusXM PREMIER OVER 160 CHANNELS

Get every channel available on your satellite radio, and enjoy all you want, all in one place. Hear commercial-free music plus sports, news, talk and entertainment. Get all the premium programming, including Howard Stern, every NFL game, Oprah Radio®, every MLB® and NHL® game, every NASCAR® race, Martha Stewart and more. And get 20+ extra channels, including SiriusXM Latino, offering 20 channels of commercial free music, news, talk, comedy, sports and more dedicated to Spanish language programming.

- To access SiriusXM Satellite Radio, press the “SXM” button on the touchscreen on the main Radio screen.

The following describes features that are available when in SiriusXM Satellite Radio mode:

Seek Up/Seek Down

- Press the Seek arrow buttons on the touchscreen for less than two seconds to seek through channels in SXM mode.
- Press and hold either arrow button on the touchscreen for more than two seconds to bypass channels without stopping. The radio will stop at the next listenable channel once the arrow button on the touchscreen is released.

Direct Tune

- Tune directly to a SXM channel by pressing the “Tune” button on the touchscreen on the screen, and entering the desired station number.

Jump

- Automatically tells you when Traffic & Weather for a favorite city is available, and gives you the option to switch to that channel. Press “Jump” to activate the feature. After listening to Traffic and Weather, press “Jump” again to return to the previous channel.

Fav

- Activates the favorites menu. You can add up to 50 favorite artists or songs. Just press “Add Fav Artist” or “Add Fav Song” while the song is playing. You will then be alerted any time one of these songs, or works by these artists, is playing on other SiriusXM channels.

SiriusXM Parental Controls

- You can skip or hide certain channels from view if you do not want access to them. Press the “Apps” button on the touchscreen, then the “Settings” button on the touchscreen, next press the “Sirius Setup” button on the touchscreen, then select Channel Skip. Press the box check-mark next to the channel you want skipped. They will not show up in normal usage.
- SiriusXM also offers the option to permanently block selected channels. Call (1-888-601-6297 for U.S. customers, 1-877-438-9677 for Canadian customers) and request the Family-Friendly Package.

Browse

Lets you browse the SiriusXM channel listing or Genre listing. Favorites, Game Zone, Weather and Jump settings also provide a way to browse the SiriusXM channel list.

Browse Sub-Menu	Sub-Menu Description
All	Shows the channel listing.
Genre	Provides a list of all genres, and lets you jump to a channel within the selected genre.
Presets	Lets you scroll the list of Preset satellite channels. Press the channel, or press Enter on the Tune knob, to go to that channel. Press the trash can icon to delete a preset. Your presets are also shown at the top of the main Satellite Radio screen.
Favorites	Lets you manage artists and songs in the Favorites list and configure Alert Settings to let you know when favorite songs or artists are playing on other channels. Also, view a list of channels airing any of your Favorites.
Game Zone	Provides alerts when your favorite sports teams are starting a game which is being aired on other SiriusXM channels, or when their game score is announced. You can select and manage your Teams list here, and configure alerts.
Jump	Lets you select your favorite cities for Traffic & Weather information, which is used by the Jump feature on the main satellite radio screen.

Replay

Lets you replay up to 44 minutes of the content of the current SiriusXM channel.

Replay Option	Option Description
Play/Pause	Press to Pause content playback. Press Pause/Play again to resume playback.
Rewind/RW	Rewinds the channel content in steps of five seconds. Press and hold to rewind continuously, then release to begin playing content at that point.
Fast Forward/FW	Forwards the content, and works similarly to Rewind/RW. However, Fast Forward/FW can only be used when content has been previously rewound.
Replay Time	Displays the amount of time in the upper center of the screen by which your content lags the Live channel.
Live	Resumes playback of Live content at any time while replaying rewound content.

- SiriusXM services require subscriptions, sold separately after the 12-month trial included with the new vehicle purchase. **If you decide to continue your service at the end of your trial subscription, the plan you choose will automatically renew and bill at then-current rates until you call SiriusXM at 1-866-635-2349 for U.S. residents and 1-888-539-7474 for Canadian residents to cancel. See SiriusXM Customer Agreement for complete terms at www.siriusxm.com (US residents) or siriusxm.ca (Canadian residents).** All fees and programming subject to change. Our satellite service is available only to those at least 18 and older in the 48 contiguous USA and D.C. Our Sirius satellite service is also available in PR (with coverage limitations). Our Internet radio service is available throughout our satellite service area and in AK and HI. ©2014 Sirius XM Radio Inc. Sirius, XM and all related marks and logos are trademarks of Sirius XM Radio Inc.

Disc Operation (If Equipped)

- Your vehicle may have a remote CD player located in the lower center console storage bin, or in the lower center bench seat bin.
- CD/Disc Mode is entered by either inserting a CD/Disc or by pressing the MEDIA button located on the side of the display. Once in Media Mode, select “Disc.”
- Gently insert one CD into the CD player with the CD label facing as indicated on the illustration located on the Disc player.

Seek Up/Down Buttons

- Press to seek through Disc tracks.
- Hold either button to bypass tracks without stopping.

Browse

- Press the “Browse” button on the touchscreen to scroll through and select a desired track on the Disc. Press the “Exit” button on the touchscreen if you wish to cancel the browse function.

MEDIA HUB — PLAYING iPod®/USB/MP3 DEVICES



Uconnect® 8.4AN Media Hub

1 — USB Charge Only Port
2 — SD Card Port

3 — USB Port
4 — Audio/AUX Jack

There are many ways to play music from iPod®/MP3 players or USB devices through your vehicle's sound system. Press your Media button on the touchscreen to begin.

Audio Jack (AUX)

- The AUX allows a portable device, such as an MP3 player or an iPod®, to be plugged into the radio and utilize the vehicle's sound system, using a 3.5 mm audio cable, to amplify the source and play through the vehicle speakers.
- Pressing the "AUX" button on the touchscreen will change the mode to auxiliary device if the audio jack is connected, allowing the music from your portable device to be heard through the vehicle's speakers. To activate the AUX, plug in the audio jack.
- The functions of the portable device are controlled using the device buttons. The volume may be controlled using the radio or portable device.
- To route the audio cable out of the center console, use the access cut out in the front of the console.

USB Port

- Connect your iPod® or compatible device using a USB cable into the USB Port. USB Memory sticks with audio files can also be used. Audio from the device can be played on the vehicles sound system while providing metadata (artist, track title, album, etc.) information on the radio display.
- When connected, the iPod®/compatible USB device can be controlled using the radio or Steering Wheel Audio Controls to play, skip to the next or previous track, browse, and list the contents.
- The iPod® battery charges when plugged into the USB port (if supported by the specific device).
- To route the USB/iPod® cable out of the center console, use the access cut out.

NOTE:

When connecting your iPod® device for the first time, the system may take several minutes to read your music, depending on the number of files. For example, the system will take approximately five minutes for every 1,000 songs loaded on the device. Also during the reading process, the Shuffle and Browse functions will be disabled. This process is needed to ensure the full use of your iPod® features and only happens the first time it is connected. After the first time, the reading process of your iPod® will take considerably less time unless changes are made or new songs are added to the playlist.

The USB port supports certain Mini, Classic, Nano, Touch, and iPhone® devices. The USB port also supports playing music from compatible external USB Mass Storage Class memory devices. Some iPod® software versions may not fully support the USB port features. Please visit Apple's website for iPod® software updates.

SD Card

- Play songs stored on an SD card inserted into the SD card slot.
- Song playback can be controlled using the radio or Steering Wheel Audio Controls to play, skip to the next or previous track, browse, and list the contents.

Bluetooth® Streaming Audio

- If equipped with Uconnect® Voice Command, your Bluetooth-equipped iPod® devices, cell phones or other media players, may also be able to stream music to your vehicle's sound system. Your connected device must be Bluetooth-compatible and paired with your system (see Uconnect® Phone for pairing instructions). You can access the music from your connected Bluetooth® device by pressing the Bluetooth® button on the touchscreen while in Media mode.

Uconnect® 8.4A & 8.4AN Available Media Hubs

Uconnect® 8.4A & 8.4AN	Media Hub (USB, AUX Ports)	Media Hub (SD, USB, AUX Ports)	Remote USB Port (Fully Functional)	Remote USB Port (Charg- ing Only)	Dual Charging Ports
	-	S	S	O	O

S = Standard Equipment

O = Optional Equipment

iPod®/CD/AUX CONTROLS



iPod®/CD/AUX Controls

- | | |
|--------------------------|--|
| 1 — Repeat Music Track | 5 — Music Track Information |
| 2 — Music Track And Time | 6 — Show Songs Currently In Cue To Be Played |
| 3 — Shuffle Music Tracks | 7 — Browse Music By |
| 4 — Music Source | |

The iPod®/CD/AUX controls are accessed by pressing the desired button on the touchscreen and choosing between Disc, AUX, iPod®, Bluetooth® or SD Card.

NOTE:

Uconnect® will automatically switch to the appropriate mode when something is first connected or inserted into the system.

NAVIGATION

- Press the “Nav” button on the touchscreen in the menu bar to access the Navigation system.

Changing The Navigation Voice Prompt Volume

1. Press the “View Map” button on the touchscreen from the Nav Main Menu.
2. With the map displayed, press the “Settings” button on the touchscreen in the lower right area of the screen.
3. In the Settings menu, press the “Guidance” button on the touchscreen.
4. In the Guidance menu, adjust the Nav Volume by pressing the “+” or “-” buttons on the touchscreen.



Uconnect® 8.4AN Navigation

1 — Find A Destination

2 — View Map

3 — Information

4 — Emergency

5 — Navigation Settings

6 — Stop A Route

7 — Detour A Route

8 — Repeat Route Guidance Prompt

Finding Points Of Interest

- From the main Navigation menu, press the “Where To?” button on the touchscreen, then press the “Points of Interest” button on the touchscreen.
- Select a Category and then a subcategory, if necessary.
- Select your destination and press the “Yes” button on the touchscreen.

Finding A Place By Spelling The Name

- From the Main Navigation Menu press the “Where to?” button on the touchscreen, press the “Points of Interest” button on the touchscreen, then press the “Spell Name” button on the touchscreen.
- Enter the name of your destination.
- Press the “List” button on the touchscreen.
- Select your destination and press the “Yes” button on the touchscreen.

One-Step Voice Destination Entry

- Enter a navigation destination without taking your hands off the wheel.
- Just press the Uconnect® Voice Command  VR button on the steering wheel, wait for the beep and say something like, "800 Chrysler Drive Auburn Hills MI."

NOTE:

Destination entry is not available while your vehicle is in motion. However, you can also use Voice Commands to enter an address while moving. Refer to Common Navigation Voice Commands in the Uconnect® Voice Command section.

Setting Your Home Location

- Press the “Nav” button on the touchscreen in the menu bar to access the Navigation system and the Main Navigation menu.
- Press the “Where To?” button on the touchscreen, then press the “Go Home” button on the touchscreen.
- You may enter your address directly, use your current location as your home address, or choose from recently found locations.
- To delete your Home location (or other saved locations) so you can save a new Home location, press the “Where To?” button on the touchscreen from the Main Navigation menu, then press the “Go Home” button on the touchscreen, and in the Yes screen press the “Options” button on the touchscreen. In the Options menu press the “Clear Home” button on the touchscreen. Set a new Home location by following the previous instructions.

Go Home

- A Home location must be saved in the system. From the Main Navigation menu, press the “Where To?” button on the touchscreen, then press the “Go Home” button on the touchscreen.



Uconnect® 8.4AN Map

- | | |
|-------------------------------|--------------------------------|
| 1 — Distance To Next Turn | 5 — Your Location On The Map |
| 2 — Next Turn Street | 6 — Navigation Main Menu |
| 3 — Estimated Time Of Arrival | 7 — Current Street Location |
| 4 — Zoom In And Out | 8 — Navigation Routing Options |

Your route is marked with a blue line on the map. If you depart from the original route, your route is recalculated. A speed limit icon could appear as you travel on major roadways.

Adding A Stop

- To add a stop you must be navigating a route.
- Press the “Menu” button on the touchscreen to return to the Main Navigation menu.
- Press the “Where To?” button on the touchscreen, then search for the extra stop. When another location has been selected, you can choose to cancel your previous route, add as the first destination or add as the last destination.
- Press the desired selection and press the “Yes” button on the touchscreen.

Taking A Detour

- To take a detour you must be navigating a route.
- Press the “Detour” button on the touchscreen.

NOTE:

If the route you are currently taking is the only reasonable option, the device may not calculate a detour. For more information, see your Uconnect® User's Manual.

SiriusXM TRAFFIC (US Market Only)

Don't Drive Through Traffic. Drive Around It.

Avoid congestion before you reach it. By enhancing your vehicle's navigation system with the ability to see detailed traffic information, you can pinpoint traffic incidents, determine average traffic speed and estimate travel time along your route. Since the service is integrated with a vehicle's navigation system, SiriusXM Traffic can help drivers pick the fastest route based on traffic conditions.

- Detailed information on traffic speed, accidents, construction, and road closings.
- Traffic information from multiple sources, including police and emergency services, cameras and road sensors.
- Coast-to-coast delivery of traffic information.
- View conditions for points along your route and beyond. Available in over 130 markets.

SiriusXM TRAVEL LINK (US Market Only)

In addition to delivering over 130 channels of the best sports, entertainment, talk, and commercial-free music, SiriusXM offers premium data services that work in conjunction with compatible navigation systems. SiriusXM Travel Link brings a wealth of useful information into your vehicle and right to your fingertips.

- **Fuel Prices** — Check local gas and diesel prices in your area and route to the station of your choice.
- **Movie Listings** — Check local movie theatres and listings in your area and route to the theater of your choice.
- **Sports Scores** — In-game and final scores as well as weekly schedules.
- **Weather** — Check variety of local and national weather information from radar maps to current and 5-day forecast.

SiriusXM Travel Link feature is completely integrated into your vehicle. A few minutes after you start your vehicle, Travel Link information arrives and updates in the background. You can access the information whenever you like, with no waiting.

To access SiriusXM Travel Link, press “Apps” button on the touchscreen, then press the “SiriusXM Travel Link” button on the touchscreen.

NOTE:

SiriusXM Travel Link requires a subscription, sold separately after the five (5) year trial subscription included with your vehicle purchase.

SiriusXM Travel Link is only available in the United States.

Fuel Prices	Check local gas and diesel prices in your area and route to the station of your choice.
Movie Listings	Check local movie theatres and listings in your area and route to the theater of your choice.
Sports Scores	In-game and final scores as well as weekly schedules.
Weather	Check variety of local and national weather information from radar maps to current and 5-day forecast.

Uconnect® Phone (Bluetooth® HANDS FREE CALLING)

- If the Uconnect® Phone Button  exists on your steering wheel, then you have the Uconnect® Phone features.
- The Uconnect® Phone is a voice-activated, hands-free, in-vehicle communications system with Voice Command Capability (see Voice Command section).
- The Uconnect® Phone allows you to dial a phone number with your mobile phone using simple voice commands or pressing the buttons on the touchscreen.
- Refer to the Understand The Features Of Your Vehicle section of your vehicle's Owner's Manual on the DVD for further details.

NOTE:

The Uconnect® Phone requires a mobile phone equipped with the Bluetooth® Hands-Free Profile, Version 1.0 or higher. For Uconnect® Customer Support: U.S. residents visit UconnectPhone.com or call 1-877-855-8400. Canadian Residents – visit UconnectPhone.com or call, 1-800-465-2001 (English) or 1-800-387-9983 (French).

Pairing A Phone

- To use the Uconnect® Phone feature, you must first pair your Bluetooth® phone with the Uconnect® system.

Start Pairing Procedure On The Radio

- Press the “Phone” button on the touchscreen and then the “settings” button on the touchscreen. Next, press “Add Device.”
- Uconnect® Phone will display an “In progress” screen while the system is connecting.

Start Pairing Procedure On Mobile Phone

- Search for available devices on your Bluetooth® enabled mobile phone. This is usually within Settings or Options under “Bluetooth.” See your mobile phone’s manual for details.
- When your phone finds the system, select “Uconnect” as the paired device. You may be prompted by your phone to download the phonebook. This is so you can make calls by saying the name of your contact (PBAP-Phone Book Access Profile).

Complete The Pairing Procedure

- When prompted on the phone, verify with the radio password shown on the Uconnect® Screen.
- If your phone asks you to accept a connection request from Uconnect®, select “Yes.” If available, check the box telling it not to ask again – that way your phone will automatically connect each time you start the vehicle.

Select The Mobile Phone's Priority Level

- When the pairing process has successfully completed, the system will prompt you to choose whether or not this is your favorite phone. Selecting “Yes” will make this phone the highest priority. This phone will take precedence over other paired phones within range. Only one phone can be paired at a time.
- You are now ready to make hands-free calls. Press the Uconnect® Phone button on your steering wheel to begin.

Making A Phone Call



To begin a phone call using Uconnect® Voice Command:

- Push the Uconnect® Phone button .
- After the BEEP, say “dial” then the number (or “call” then the name as listed in your phone; see Phonebook).

NOTE:

You can also initiate a call by using the touchscreen on the Phone main screen.

Receiving A Call — Accept (And End)

- When an incoming call rings/is announced on Uconnect®, push the Phone button .
- To end a call, push the Phone button .

Mute (Or Unmute) Microphone During Call

- During a call, press the “mute” button on the touchscreen to mute and unmute the call.

Transfer Ongoing Call Between Handset And Vehicle

During an on-going call, press the “Transfer” button on the touchscreen to transfer an on-going call between handset and vehicle.

Common Phone Commands (Examples)

- “Call John Smith”
- “Call John Smith mobile”
- “Dial 1 248 555 1212”
- “Call Emergency”
- “Call Towing Assistance”
- “Redial”



Phonebook

- Uconnect® radios will automatically download your phonebook from your paired phone, if this feature is supported by your phone. Entries are updated each time that the phone is connected. If your phone book entries do not appear, check the settings on your phone. Some phones require you to enable this feature manually.
- Your phonebook can be browsed on your radio screen, but editing can only be done on your phone. To browse, press the “Phone” button on the touchscreen, then the “Phonebook” button on the touchscreen.
- Favorite phonebook entries can be saved as Favorites for quicker access. Favorites are shown at the top of your main phone screen.

Changing The Volume

- Start a dialogue by pressing the Phone button , then say a command for example - "Help".
- Use the radio VOLUME/MUTE rotary knob to adjust the volume to a comfortable level while the Uconnect® system is speaking. Please note the volume setting for Uconnect® is different than the audio system.

NOTE:

To access help, press the Uconnect® Phone  button on the steering wheel and say "help." Touch the display or push either  or  VR button and say "cancel" to cancel the help session.

Voice Text Reply (Not Compatible With iPhone®)

Once your Uconnect® system is paired with a compatible mobile device, the system can announce a new incoming text message, and read it to you over the vehicle audio system. You can reply to the message using Voice Recognition, by selecting, or saying one of the 18 pre-defined messages.

- **Here's How:** Press the Uconnect® Phone button  and wait for the beep, then say "reply." Uconnect® will give the following prompt: "Please say the message you would like to send." Wait for the beep and say one of the pre-defined messages. (If you are not sure, you can say "help"). Uconnect® will then read the pre-defined messages allowed. As soon as you hear the message you would like to send, you can interrupt the list of prompts by pressing the Uconnect® phone button and saying the phrase. Uconnect® will confirm the message by reading it back to you. Then press the Phone button and say "Send."

PRE-DEFINED VOICE TEXT REPLY RESPONSES		
Yes.	Stuck in Traffic.	See you later.
No.	Start without me.	I'll be Late.
Okay.	Where are you?	I will be <number> minutes late.
Call me.	Are you there yet?	
I'll call you later.	I need directions.	See you in <number> of minutes.
I'm on my way.	Can't talk right now.	Thanks.
I'm lost.		

Voice texting reply and voice texting features require a compatible mobile device enabled with Bluetooth® Message Access Profile (MAP). iPhone® and some other smartphones do not currently support Bluetooth® MAP. U.S. residents can visit UconnectPhone.com for system and device compatibility. Canadian residents can visit UconnectPhone.com for system and device compatibility.

Want to dictate a personal message? You must first register with Uconnect® Access to take advantage of a new, cloud-based Voice Texting service, an enhancement to Voice Text Reply.



WARNING!

- Any voice commanded system should be used only in safe driving conditions following applicable laws regarding phone use. Your attention should be focused on safely operating the vehicle. Failure to do so may result in a collision causing you and others to be severely injured or killed.
- In an emergency, to use Uconnect® Phone, your mobile phone must be:
 - turned on,
 - paired to Uconnect® Phone,
 - and have network coverage.



VOICE COMMAND QUICK REFERENCE

Uconnect® 8.4AN Voice Command Quick Reference



If the Uconnect® Voice Command  VR button exists on your steering wheel, you have the Voice Command feature, which is optimized for the driver. The Voice Command feature lets you keep your hands on the wheel and your eyes on the road.

- When you push the Voice Command  VR button located on the steering wheel, you will hear a beep. After the beep, give your command. If you do not know what commands to say, you can say “help” and the system will provide options to you. If you ever wish to interrupt the system while it lists options, push the Voice Command  VR button, and after the beep, say your command.



NOTE:

All phone oriented voice commands are accessible by first pushing the Phone Pick Up  button, not the Voice Command button. To end a call simply push the Phone Hang Up  button. In some vehicles, the Phone Pickup  button serves the dual purpose of ending calls as well.

Voice Command (VR) User TIPS

- To hear available commands, push the Uconnect® Voice Command  VR button and say “Help.” You will hear available commands for the menu displayed.
- At any time, you can say the words “Cancel” or “Help.” These commands are universal and can be used from virtually any menu. All other specific commands can be used depending upon the active application.
- You can interrupt the system prompts at any time by pushing the Uconnect® Voice Command  VR button while the system is speaking. After the beep, you can say a command.
- You can “chain” commands together for faster results. Say “Call Joe Doe mobile,” for example.
- For best performance, adjust the rearview mirror to provide at least ½ in (1 cm) gap between the overhead console (if equipped) and the mirror.
- Always wait for the beep before speaking.
- Speak normally, without pausing, just as you would speak to a person sitting a few feet/meters away from you.
- Ensure that no one other than you is speaking during a Voice Command period.

Steering Wheel Buttons

- You can control many of your radio features using your voice. Push either the Uconnect® Voice Command  VR button, or the Phone Pick Up  button on your steering wheel.

Available Radio Button On The Touchscreen Voice Commands



	Steering Wheel Buttons to Push:	(1) Radio Mode	(2) Media Mode	(3) Climate Controls	(4) Navigation	(5) Phone Mode	(6) APPS	
Types of Voice Commands Available	Uconnect® Voice Command (VR) Button	AM/FM & Satellite Band Control	Media Devices Control	Temperature Control	Destination Selection and View	-	Yelp®	
		GENERAL						
	Uconnect® Phone Pick Up Button	-	-	-	-	Call Initiation, Call Management, Pre-defined Voice Text Reply	-	

Voice Command Examples – Uconnect® 8.4AN

While In:	Voice Command Example:
GENERAL	
Anytime	<p>“Go to Radio” (Media, Climate, Navigation, Phone, Apps) – Settings, and Controls are not Voice Command accessible “Cancel”</p> <p>“Help” (to listen to suggested commands specific to current need) “Repeat”</p> <p>“Launch Yelp®” – Required 1st voice command to launch Yelp® app “Yelp® Search” – Required 2nd voice command to activate app functionality using Steering Wheel Voice Control Button</p>
RADIO	
AM/FM	“Tune to AM950”, “Tune to 95.5FM (preset 5)”
Satellite Band Control	“Tune to Satellite Channel 80's on 8”, Tune to Satellite Channel 32 (preset 4)
MEDIA	
Media Devices Control (Functionality is dependent on compatibility between devices and radio)	<p>“Browse” (show) “artist” (albums, music) “Show paired phones” (devices) “Play song – Maple Leaf Rag” (artist - Scott Joplin, genre - rock, album - Ragtime Favorites) “Shuffle” – available with iPod, USB and SD Card</p>
CLIMATE	
Temperature Control	<p>“Set temperature to 70 degrees” – single climate zone vehicles</p> <p>“Set driver” (passenger) “temperature to 75 degrees” – dual climate zone vehicles</p>
NAVIGATION	
Destination Selection & View	<p>“Navigate to” (Destination) 123 Any Street, Any town, Any State (any full address) “Go Home” – destination previously defined by driver “Repeat guidance” – hear the last navigation prompt “Cancel Route” “View Map”</p>

While In:	Voice Command Example:
PHONE	
<p>Call Initiation (Requires that phone has been Bluetooth® paired with radio)</p>	<p>“Dial 123-456-7890” (phone number) “Call John Smith mobile” (home, office, other) “Redial” “Show outgoing” (recent) “calls”</p>
<p>Call Management</p>	<p>“Search for John Smith” (any contact name in address book) “Show (display list) contacts”</p>
<p>Voice Texting (Requires registration with Uconnect® Access and a current subscription)</p> <p>NOTE: Requires a compatible mobile device enabled with Bluetooth Message Access Profile (MAP). iPhone and some other smartphones do not currently support Bluetooth® MAP. Visit Uconnectphone.com for system and device compatibility.</p>	<p>Create a text message using Voice Command Capability “Send a message to John Smith (123-456-7890)” “Show Messages” “Listen to” (view) “number 4” “Reply” “Forward text” (message) “to John Smith” (phone type, number)</p>
<p>Voice Text Reply (Radio audibly recognizes these 18 pre-defined SMS messages as you speak)</p> <p>NOTE: Requires a compatible mobile device enabled with Bluetooth Message Access Profile (MAP). iPhone and some other smartphones do not currently support Bluetooth® MAP. Visit Uconnectphone.com for system and device compatibility.</p>	<p>Forward one of 18 pre-defined SMS messages to incoming calls/text messages: “Yes.” “No.” “Okay.” “I can’t talk right now.” “Call me.” “I’ll call you later.” “I’m on my way.” “Thanks.” “I’ll be late.” “I will be <number> minutes late.” “See you in <number> minutes” “Stuck in traffic.” “Start without me.” “Where are you?” “Are you there yet?” “I need directions.” “I’m lost.” “See you later.”</p>

While In:	Voice Command Example:
APPS	
<p>SiriusXM Travel Link (Traffic function is not voice command accessible within SiriusXM Travel Link)</p>	<p>“Show Fuel prices” “Show Current Weather” – provides access to Forecast as well “Show Weather map” – multiple map formats available “Show Sports” “Show Movie listings” “Show My favorites”</p>
<p>Yelp® (Yelp® adds it's own audible prompts, and response time varies depending on carrier coverage speed)</p>	<p>“Launch Yelp®” – Required 1st voice command to launch Yelp® app “Yelp® Search” – Required 2nd voice command to activate app functionality using Steering Wheel Voice Control Button “Hotel” (restaurant, gas station, mail, hospital) – for nearest desired general POI “Italian restaurants” – for nearest specified POI category</p>

STEERING WHEEL AUDIO CONTROLS

The steering wheel audio controls are located on the rear surface of the steering wheel.

Right Switch

- Push the switch up or down to increase or decrease the volume.
- Push the button in the center to change modes AM/FM/CD/SXM.

Left Switch

- Push the switch up or down to search for the next listenable station or select the next or previous CD track.
- Push the button in the center to select the next preset station (radio) or to change CDs if equipped with a CD Changer.



Steering Wheel Audio Controls

ELECTRONIC VEHICLE INFORMATION CENTER (EVIC) OR DRIVER INFORMATION DISPLAY (DID)

The EVIC/DID features an interactive display that is located in the instrument cluster. Pushing the controls on the left side of the steering wheel allows the driver to select vehicle information and Personal Settings. For additional information, refer to “Programmable Features” in this guide.

- Push and release the UP \blacktriangle button to scroll upward through the main menus and submenus (Digital Speedometer, Vehicle Info, Fuel Economy Info, Trip A, Trip B, Stop/Start, Trailer Tow, Audio, Stored Messages, Screen Setup, Vehicle Settings).
- Push and release the DOWN \blacktriangledown button to scroll downward through the main menus and submenus.
- Push and release the RIGHT \blacktriangleright button for access to main menus, submenus or to select a personal setting in the setup menu. Push and hold the RIGHT \blacktriangleright button for two seconds to reset features.
- Push and release the BACK/LEFT \blacktriangleleft button to scroll back to a previous menu or submenu.



EVIC/DID Controls

Compass Calibration

This compass is self-calibrating, which eliminates the need to set the compass manually. When the vehicle is new, the compass may appear erratic and the EVIC/DID will display “CAL” until the compass is calibrated.

You may also calibrate the compass by completing one or more 360 degree turns (in an area free from large metal or metallic objects) until the “CAL” message displayed in the EVIC/DID turns off. The compass will now function normally.

PROGRAMMABLE FEATURES

Programmable Features

The EVIC/DID can be used to view or change the following settings. Push the UP Δ or DOWN ∇ button until System Setup displays, then push RIGHT \triangleright button. Scroll through the settings using the UP or DOWN buttons. Push the RIGHT \triangleright button to change the setting. Push the BACK/LEFT \triangleleft button to scroll back to a previous menu or sub menu.

- Language Select
- Units
- ParkSense
- Tilt Mirror in Reverse
- Rain Sensing Wipers
- Hill Start Assist
- Headlights Off Delay
- Illuminated Approach
- Headlights On with Wipers
- Automatic Highbeams
- Flash Lights with Lock
- Auto Lock Doors
- Auto Unlock Doors
- Sound Horn with Remote Start
- Sound Horn with Remote Lock
- Remote Unlock Sequence
- Key Fob Linked to Me
- Passive Entry
- Remote Start Comfort System
- Easy Exit Seat
- Key-off Power Delay
- Commercial Settings
- Air Suspension Display Alerts
- Aero Ride Height Mode
- Tire/Jack Mode
- Transport Mode
- Wheel Alignment Mode
- Horn w/ Remote Lower
- Lights w/ Remote Lower
- Trailer Select
- Brake Type
- Trailer Name
- Compass Variance
- Calibrate Compass
- Fuel Saver Display
- Park Assist Front Chime Volume
- Park Assist Rear Chime Volume

Uconnect® Customer Programmable Features

The Uconnect® system allows you to access Customer Programmable feature settings such as Display, Voice, Clock, Safety & Driving Assistance, Lights, Doors & Locks, Auto-On Comfort, Engine Off Options, Compass Settings (Uconnect® 5.0,) Trailer Brake, Suspension, Audio, Phone/Bluetooth®, SiriusXM Setup, Restore Settings, Clear Personal Data, and System Information through buttons on the touchscreen.

- Push the SETTINGS button (Uconnect® 5.0), or press the “Apps” button (Uconnect® 8.4) located near the bottom of the touchscreen, then press the “Settings” button on the touchscreen to access the Settings screen. When making a selection, scroll up or down until the preferred setting is highlighted, then press the preferred setting until a check-mark appears next to the setting, showing that setting has been selected. The following feature settings are available:
 - Display
 - Voice
 - Clock
 - Safety & Driving Assistance
 - Lights
 - Doors & Locks
 - Auto-On Comfort
 - Engine Off Options
 - Trailer Brake
 - Suspension
 - Audio
 - Phone/Bluetooth®
 - SiriusXM Setup
 - Restore Settings
 - Clear Personal Data
 - System Information
 - Compass Settings (Uconnect® 5.0)

NOTE:

Depending on the vehicles options, feature settings may vary.

Refer to “Uconnect Settings/Customer Programmable Features” found within “Understanding Your Instrument Panel” located in your Owner's Manual on the DVD for further information.

Instrument Cluster Reconfigurable Screen Setup

The following settings allow you to change what information is displayed in the instrument cluster as well as the location that information is displayed.

Digital Speedometer

- Push the UP or DOWN arrow button until the Digital display icon is highlighted in the EVIC/DID. Push the RIGHT arrow button to change the display between km/h and mph.

Vehicle Info (Customer Information Features)

- Push the UP or DOWN button until the Vehicle Info icon is highlighted in the EVIC/DID Display. Push the RIGHT or LEFT to scroll through the following Vehicle Info submenus:
 - Tire Pressure Monitor System
 - Air Suspension — If Equipped
 - Coolant Temperature (Diesel Only)
 - Transmission Temperature (ATX Only)
 - Oil Temperature
 - Oil Pressure
 - Oil Life
 - Fuel Filter Life (Diesel Only)
 - Battery Voltage
 - Exhaust Brake (Diesel Only)
 - Turbo Boost (Diesel Only)
 - Gauge Summary
 - Coolant Temperature (Diesel Only)
 - Transmission Temperature (ATX Only)
 - Oil Temperature
 - Oil Pressure
 - Engine Hours

Trip A

- Push the UP or DOWN arrow button until the Trip A icon is highlighted in the EVIC/DID. Push and hold the RIGHT arrow button to reset the Trip A information.

Trip B

- Push the UP or DOWN arrow button until the Trip B icon is highlighted in the EVIC/DID. Push and hold the RIGHT arrow button to reset the Trip B information.

Fuel Economy

- Push the UP or DOWN arrow button until the Fuel Economy icon is highlighted. The screen will display the following:
 - Average Fuel Economy/Miles Per Gallon
 - Range To Empty (RTE)
 - Current Miles Per Gallon (MPG)
 - Dual Tanks- If Equipped Heavy Duty only

Stop/Start

- Push the UP or DOWN arrow button until the Stop/Start icon is highlighted in the EVIC/DID. Push the RIGHT arrow button to display the Stop/Start status.

Trailer Tow

- Push the UP or DOWN arrow button until the Trailer Tow icon is highlighted. The screen will display the following information:
 - Trailer Trip Distance

Audio

- Push the UP or DOWN arrow button until the Audio display icon is highlighted in the EVIC/DID. This screen will display the current media source.

Screen Setup

- Push the UP or DOWN arrow button until the Screen Setup display icon is highlighted in the EVIC/DID. Push the RIGHT arrow button to enter the Screen Setup sub-menu. The Screen Setup feature allows you to change what information is displayed in the instrument cluster as well as the location that information is displayed.

UNIVERSAL GARAGE DOOR OPENER (HOMELINK®)

HomeLink® replaces up to three hand-held transmitters that operate devices such as garage door openers, motorized gates, lighting or home security systems. The HomeLink® unit is powered by your vehicles 12 Volt battery.

The HomeLink® buttons that are located in the overhead console or sunvisor designate the three different HomeLink® channels.

The HomeLink® indicator is located above the center button.

Before You Begin Programming HomeLink®

Ensure that your vehicle is parked outside of the garage before you begin programming.

For efficient programming and accurate transmission of the radio-frequency signal, it is recommended that a new battery be placed in the hand-held transmitter of the device that is being programmed to the HomeLink® system.

To erase the channels, place the ignition switch into the ON/RUN position, then push and hold the two outside HomeLink® buttons (I and III) for up to 20 seconds or until the red indicator flashes.



Universal Garage Door Opener (HomeLink®) Buttons

NOTE:

Erasing all channels should only be performed when programming HomeLink® for the first time. Do not erase channels when programming additional buttons.

If you have any problems, or require assistance, please call toll-free 1-800-355-3515 or, on the Internet at HomeLink.com for information or assistance.

Programming A Rolling Code

NOTE:

For programming Garage Door Openers that were manufactured after 1995. These Garage Door Openers can be identified by the "LEARN" or "TRAIN" button located where the hanging antenna is attached to the Garage Door Opener. It is NOT the button that is normally used to open and close the door. The name and color of the button may vary by manufacturer.

1. Place the ignition switch into the ON/RUN position.
2. Place the hand-held transmitter 1 to 3 in (3 to 8 cm) away from the HomeLink® button you wish to program while keeping the HomeLink® indicator light in view.
3. Simultaneously press and hold both the HomeLink® button you want to program and the hand-held transmitter button.
4. Continue to hold the buttons until the EVIC/DID display changes from "CHANNEL # TRAINING" to "CHANNEL # TRAINED", then release both buttons.

NOTE:

If the EVIC/DID displays "DID NOT TRAIN" repeat from Step 2.

5. At the garage door opener motor (in the garage), locate the "LEARN" or "TRAINING" button. This can usually be found where the hanging antenna wire is attached to the garage door opener motor. Firmly press and release the "LEARN" or "TRAINING" button.

NOTE:

You have 30 seconds in which to initiate the next step after the LEARN button has been pressed.

6. Return to the vehicle and press the programmed HomeLink® button twice (holding the button for two seconds each time). The EVIC/DID will display "CHANNEL # TRANSMIT". If the garage door opener/device activates, programming is complete.

NOTE:

If the device does not activate, press the button a third time (for two seconds) to complete the training.

7. To program the remaining two HomeLink® buttons, repeat each step for each remaining button. DO NOT erase the channels.

Programming A Non-Rolling Code

NOTE:

For programming Garage Door Openers manufactured before 1995.

1. Turn the ignition switch to the ON/RUN position.
2. Place the hand-held transmitter 1 to 3 in (3 to 8 cm) away from the HomeLink® button you wish to program while keeping the HomeLink® indicator light in view.
3. Simultaneously press and hold both the HomeLink® button you want to program and the hand-held transmitter button.
4. Continue to hold both buttons until the EVIC/DID display changes from “CHANNEL # TRAINING” to “CHANNEL # TRAINED”, then release both buttons.
5. Press and hold the programmed HomeLink® button and observe the indicator light.

NOTE:

If the EVIC/DID displays “DID NOT TRAIN” repeat from Step 2.

- To program the two remaining HomeLink® buttons, repeat each step for each remaining button. DO NOT erase the channels.

Using HomeLink®

To operate, push and release the programmed HomeLink® button. Activation will now occur for the programmed device (i.e., garage door opener, gate operator, security system, entry door lock, home/office lighting, etc.,). The hand-held transmitter of the device may also be used at any time.

WARNING!

- Your motorized door or gate will open and close while you are programming the universal transceiver. Do not program the transceiver if people or pets are in the path of the door or gate.
- Do not run your vehicle in a closed garage or confined area while programming the transceiver. Exhaust gas from your vehicle contains Carbon Monoxide (CO) which is odorless and colorless. Carbon Monoxide is poisonous when inhaled and can cause you and others to be severely injured or killed.

POWER INVERTER

A 115 Volt, 150 Watt power inverter outlet is located on the lower instrument panel next to the climate control knob. This outlet can power cellular phones, electronics and other low power devices requiring power up to 150 Watts.

To turn on the power outlet, simply plug in the device. The outlet automatically turns off when the device is unplugged.

NOTE:

The power inverter is designed with built-in overload protection. If the power rating of 150 Watts is exceeded, the power inverter will automatically shut down. Once the electrical device has been removed from the outlet, the inverter should automatically reset.



Power Inverter

WARNING!

To Avoid Serious Injury or Death DO NOT:

- insert any objects into the receptacles
- touch with wet hands

Close the lid when not in use. If this outlet is mishandled, it may cause an electric shock and failure.

POWER OUTLETS

The auxiliary 12 Volt (13 Amp) power outlets can provide power for in-cab accessories designed for use with the standard “cigar lighter” plug. The 12 Volt power outlets have a cap attached to the outlet indicating “12V DC”, together with either a key symbol or a battery symbol.

ELECTRONICS

The auxiliary power outlets can be found in the following locations:

- Lower left and lower right in the center of the instrument panel – if equipped with a column or a eight-speed electronic shifter.
- Inside the top storage tray.



Power Outlet — Center Console

- Inside the upper lid of the center storage compartment — if equipped.



Power Outlet — Storage Compartment

- Rear of the center console storage compartment — Quad Cab® or Crew Cab.



Power Outlet — Rear Console

NOTE:

- Do not exceed the maximum power of 160 Watts (13 Amps) at 12 Volts. If the 160 Watt (13 Amp) power rating is exceeded, the fuse protecting the system will need to be replaced.
- Power outlets are designed for accessory plugs only. Do not insert any other object in the power outlet as this will damage the outlet and blow the fuse. Improper use of the power outlet can cause damage not covered by your new vehicle warranty.
- The rear center console power outlet can be switched to “battery” powered all the time by switching the power outlet rear center console fuse in the fuse panel.

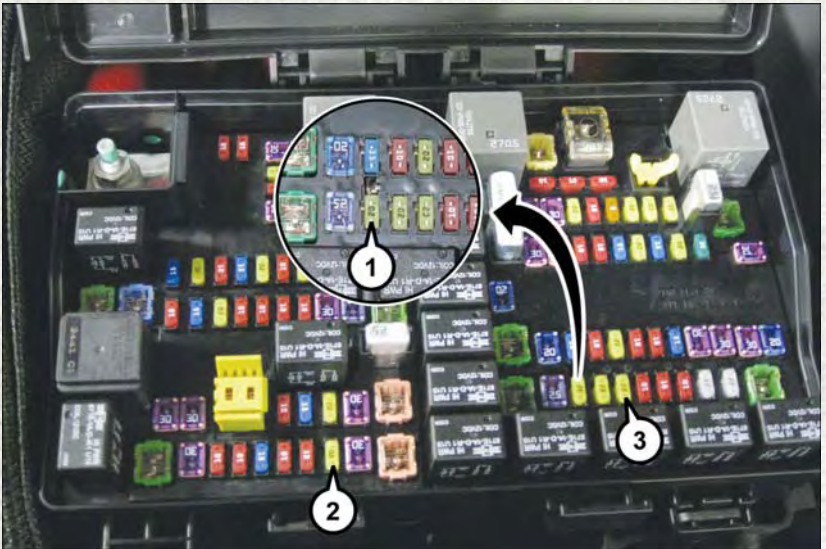

Power Outlet Fuse Locations

- 1 — F90 – F91 Fuse 20A Yellow Power Outlet Rear Center Console
 - 2 — F104 Fuse 20A Yellow Power Outlet Center Console
 - 3 — F93 Fuse 20A Yellow Cigar Lighter Instrument Panel
-

OFF-ROAD CAPABILITIES

ELECTRONICALLY SHIFTED FOUR WHEEL DRIVE OPERATION

The four position electronically shifted transfer case provides four mode positions:

- Two-wheel drive high range (2WD)
- Four-wheel drive high range (4WD LOCK)
- Four-wheel drive low range (4WD LOW)
- NEUTRAL (N)

This transfer case is intended to be driven in the 2WD position for normal street and highway conditions, such as dry, hard-surfaced roads.

When additional traction is required, the 4WD LOCK and 4WD LOW positions can be used to lock the front and rear drive-shafts together.

When operating your vehicle in 4WD LOW, do not exceed 25 mph (40 km/h).

Shifting Procedure

Shifting between 2WD and 4WD LOCK can be made with the vehicle stopped or in motion at speeds up to 55 mph (88 km/h).

Shifting between 2WD or 4WD LOCK into 4WD LOW must be made with the transmission in NEUTRAL and the vehicle stopped or rolling at 2 to 3 mph (3 to 5 km/h).

NOTE:

It is preferred to have the engine running and the vehicle moving at 2 to 3 mph (3 to 5 km/h).



Four-Position/Part Time Transfer Case

- 1 — Neutral Button
- 2 — Rotary 2WD/4WD Control Knob

WARNING!

You or others could be injured if you leave the vehicle unattended with the transfer case in the NEUTRAL position without first fully engaging the parking brake. The transfer case NEUTRAL position disengages both the front and rear driveshafts from the powertrain and will allow the vehicle to move regardless of the transmission position. The parking brake should always be applied when the driver is not in the vehicle.

OFF-ROAD CAPABILITIES

These five position electronically shifted transfer cases provide five mode positions:

- Two-wheel drive high range (2WD)
- Four-wheel drive automatic range (4WD AUTO)
- Four-wheel drive lock range (4WD LOCK)
- Four-wheel drive low range (4WD LOW)
- NEUTRAL (N)

These electronically shifted transfer cases are designed to be driven in the two-wheel drive position (2WD) or four-wheel drive position (4WD AUTO) for normal street and highway conditions on dry, hard-surfaced roads.

Driving the vehicle in 2WD will have greater fuel economy benefits as the front axle is not engaged in 2WD.



Five-Position/On-Demand Transfer Case

- 1 — Neutral Button
- 2 — Rotary 2WD/4WD Control Knob



Five-Position/On-Demand Transfer Case — Eight Speed Transmission Only

OFF-ROAD CAPABILITIES

Shifting Procedure

Shifting between 2WD and 4WD AUTO or 4WD LOCK can be made with the vehicle stopped or in motion at speeds up to 55 mph (88 km/h).

Shifting between 2WD, 4WD AUTO and 4WD LOCK into 4WD LOW must be made with the transmission in NEUTRAL and the vehicle stopped or rolling at 2 to 3 mph (3 to 5 km/h).

NOTE:

It is preferred to have the engine running and the vehicle moving at 2 to 3 mph (3 to 5 km/h).

WARNING!

You or others could be injured if you leave the vehicle unattended with the transfer case in the NEUTRAL position without first fully engaging the parking brake. The transfer case NEUTRAL position disengages both the front and rear driveshafts from the powertrain and will allow the vehicle to move regardless of the transmission position. The parking brake should always be applied when the driver is not in the vehicle.

TONNEAU COVER

The Tonneau Cover can be removed and reinstalled by using the locking clamps located underneath the Tonneau Cover.

NOTE:

Be sure that the Tonneau Cover is secured before driving.

EASY-OFF TAILGATE

To simplify mounting of a camper unit with an overhang, the tailgate can be removed.

NOTE:

If your vehicle is equipped with a rear camera or RKE the electrical connector must be disconnected prior to removing the tailgate.

Removing The Tailgate

1. Disconnect the wiring harness for the rear camera or RKE (if equipped).
2. Unlatch the tailgate and remove the support cables by releasing the lock tang from the pivot.
3. Raise the right side of the tailgate until the right side pivot clears the hanger bracket.
4. Slide the entire tailgate to the right to free the left side pivot.
5. Remove the tailgate from the vehicle.

NOTE:

Do not carry the tailgate loose in the truck pickup box.

Locking Tailgate

The lock is located next to the tailgate handle. The tailgate can be locked using the vehicle key.

WARNING!

To avoid inhaling carbon monoxide, which is deadly, the exhaust system on vehicles equipped with "Cap or Slide-In Campers" should extend beyond the overhanging camper compartment and be free of leaks.

PICKUP BOX

You can carry wide building materials (sheets of plywood, etc.) by building a raised load floor. Place lumber across the box in the indentations provided above the wheel housings and in the bulkhead dividers to form the floor.

There are stampings in the sheet metal on the inner side bulkheads of the box in front of and behind both wheel housings. Place wooden boards across the box from side to side to create separate load compartments in the pickup box.

There are four tie-down cleats bolted to the lower sides of the pickup box that can sustain loads up to 1000 lbs (450 kg) total.

Cargo Camera

Your vehicle may be equipped with the Cargo Camera that allows you to see a image of the inside of the pickup box. The image will be displayed in the Uconnect® screen.

- A display timer is initiated when the cargo camera image is displayed. The image will continue to be displayed until the display timer exceeds 10 seconds and the vehicle speed is above 8 mph (13 km/h) or the image is deactivated by touching the Uconnect® display.

NOTE:

If the vehicle speed remains below 8 mph (13 km/h), the cargo camera image will be displayed continuously until deactivated by touching the Uconnect® display.

The Cargo Camera is located in the bottom center area of the center high-mounted stoplamp (CHMSL).

NOTE:

If snow, ice, mud, or any foreign substance builds up on the camera lens, clean the lens, rinse with water, and dry with a soft cloth. Do not cover the lens.

Turning Cargo Camera On Or Off — With Uconnect® 8.4A/8.4AN

1. Press the “Controls” button located on the bottom of the Uconnect® display.
2. Press the “Cargo Camera” button to turn the Cargo Camera system ON.

NOTE:

The Cargo Camera image may be deactivated by touching the Uconnect® display. The previous selected screen will appear.



Cargo Camera Display

WARNING!

- The pickup box is intended for load carrying purposes only, not for passengers, who should sit in seats and use seat belts.
- Care should always be exercised when operating a vehicle with unrestrained cargo. Vehicle speeds may need to be reduced. Severe turns or rough roads may cause shifting or bouncing of the cargo that may result in vehicle damage. If wide building materials are to be frequently carried, the installation of a support is recommended. This will restrain the cargo and transfer the load to the pickup box floor.
- If you wish to carry more than 600 lbs (272 kg) of material suspended above the wheelhouse, supports must be installed to transfer the weight of the load to the pickup box floor or vehicle damage may result. The use of proper supports will permit loading up to the rated payload.
- Unrestrained cargo may be thrown forward in an accident causing serious or fatal injury.

RAMBOX®



RamBox® Features

- 1 — Bed Extender
- 2 — Bed Rail Tie-Down System Adjustable Cleats
- 3 — Storage Bin
- 4 — Press The Button To Open

The RamBox® system is an integrated pickup box storage and cargo management system consisting of three features:

- Integrated box side storage bins
- Cargo extender/divider
- Bed rail tie-down system

RamBox® Integrated Box Side Storage Bins

The cargo storage bins provide watertight, lockable, illuminated storage for up to 150 lbs (68 kg) of evenly distributed cargo.

- To open a storage bin, press and release the pushbutton located on the lid.
- The interior of the RamBox® will automatically illuminate when the lid is opened. Pushing the switch once will turn off the bin lights, pushing the switch again will turn the lights back on.
- Storage bins feature two removable drain plugs (to allow water to drain from bins). To remove plug, pull up on the edge. To install, push plug downward into drain hole.

The RamBox® storage bins can be locked and unlocked using the vehicle key or the remote keyless entry transmitter.

NOTE:

Provisions are provided in the bins for cargo dividers and shelf supports. These accessories (in addition to other RamBox® accessories) are available from MOPAR®.

RamBox® Storage Bin Cover Emergency Release Lever

As a security measure, a Storage Bin Cover Emergency Release is built into the storage bin cover latching mechanism.

NOTE:

In the event of an individual being locked inside the storage bin, the storage bin cover can be opened from inside of the bin by pulling on the glow-in-the-dark lever attached to the storage bin cover latching mechanism.

Bed Extender

The bed extender has three functional positions:

- Storage Position
- Divider Position
- Extender Position

Storage Position

The storage position for the bed extender is at the front of the truck bed.

To install the bed extender into the storage position, perform the following:

1. Make sure the center handle is unlocked using the vehicle key and rotate the center handle vertically to release the extender side gates.
2. With the side gates open, position the extender fully forward in the bed against the front panel.
3. Rotate the side gates closed allowing the outboard ends to be positioned in front of the cargo tie-down loops.
4. Rotate the center handle horizontally to secure the side gates in the closed position.
5. Lock the center handle using the vehicle key to secure the panel into place and assist against theft.

Divider Position

There are 11 divider slots along the bed inner panels which allow for various positions to assist in managing your cargo.

To install the bed extender into a divider position perform the following:

1. Make sure the center handle is unlocked using the vehicle key and rotate the center handle vertically to release the extender side gates.
2. With the side gates open, position the extender so the outboard ends align with the intended slots in the sides of the bed.
3. Rotate the side gates closed so that the outboard ends are secured into the intended slots of the bed.
4. Rotate the center handle horizontally to secure the side gates in the closed position.
5. Lock the center handle to secure the panel into place and assist against theft.

Extender Position

The bed extender will add an additional 15 in (38 cm) in the back of the truck when additional cargo room is needed.

To install the bed extender into the extender position, perform the following:

1. Lower the tailgate.
2. Make sure the center handle is unlocked and rotate the center handle vertically in order to release the extender side gates.
3. Fit the end of the side gate ends onto the pin and handle.
4. Rotate the handles to the horizontal position to secure into place.

Bed Rail Tie-Down System

There are two adjustable cleats on each side of the bed that can be used to assist in securing cargo.

Each cleat must be located and tightened down in one of the detents, along either rail, in order to keep cargo properly secure.

- To move the cleat to any position on the rail, turn the nut counterclockwise, approximately three turns. Then, pull out on the cleat and slide it to the detent nearest the desired location. Make sure the cleat is seated in the detent and tighten the nut.
- To remove the cleats from the utility rail, remove the end cap by pushing up on the locking tab, located on the bottom of the end cap. Slide the cleat off the end of the rail.

CAUTION!

Failure to follow the following items could cause damage to the vehicle:

- Assure that all cargo inside the storage bins is properly secured.
- Do not exceed cargo weight rating of 150 lb (68 kg) per bin.
- Leaving the lid open for extended periods of time could cause the vehicle battery to discharge. If the lid is required to stay open for extended periods of time, it is recommended that the bin lights be turned off manually using the on/off switch.
- Ensure cargo bin lids are closed and latched before moving or driving vehicle.
- Loads applied to the top of the bin lid should be minimized to prevent damage to the lid and latching/hinging mechanisms.
- Damage to the RamBox® bin may occur due to heavy/sharp objects placed in bin that shift due to vehicle motion. In order to minimize potential for damage, secure all cargo to prevent movement and protect inside surfaces of bin from heavy/sharp objects with appropriate padding.
- The maximum load per cleat should not exceed 250 lbs (113 kg) and the angle of the load on each cleat should not exceed 60 degrees above horizontal, or damage to the cleat or cleat rail may occur.

WARNING!

- Always close the storage bin covers when your vehicle is unattended or in motion.
- Do not allow children to have access to the storage bins. Once in the storage bin, young children may not be able to escape. If trapped in the storage bin, children can die from suffocation or heat stroke.
- In a collision, serious injury could result if the storage bin covers are not properly latched.
- Do not use a storage bin latch as a tie down.
- To reduce the risk of potential injury or property damage:
 - Cargo must be secured.
 - Do not exceed cargo load rating of your vehicle.
 - Secure all loads to truck utilizing cargo tie-downs.
 - Extender should not be used as cargo tie-down.
 - When vehicle is in motion do not exceed 150 lbs (68 kg) load on the tailgate.
 - The bed extender is not intended for off road use.
 - When not in use, the extender/divider should be in stowed or divider position with the tailgate closed.
 - When in use, all handles are to be in the locked position.

TOWING & PAYLOAD

NOTE:

For additional trailer towing information (maximum trailer weight ratings) refer to the following website addresses:

- ramtrucks.com/en/towing_guide/
- ramtruck.ca (Canada)
- rambodybuilder.com

TOW/HAUL MODE

When driving in hilly areas, towing a trailer, carrying a heavy load, etc., and frequent transmission shifting occurs, press the TOW/HAUL switch to select TOW/HAUL mode. This will improve performance and reduce the potential for transmission overheating or failure due to excessive shifting. When operating in TOW/HAUL mode, transmission upshifts are delayed, and the transmission will automatically downshift (for engine braking) during steady braking maneuvers.

The “TOW/HAUL Indicator Light” will illuminate in the instrument cluster to indicate that TOW/HAUL mode has been activated. Pressing the switch a second time restores normal operation. If the TOW/HAUL mode is desired, the switch must be pressed each time the engine is started.



TOW/HAUL Switch

INTEGRATED TRAILER BRAKE MODULE

The Integrated Trailer Brake Controller allows you to automatically or manually activate the Electric Trailer Brakes and Electric Over Hydraulic Trailer Brakes for a better braking performance when towing a trailer.

NOTE:

The Integrated Trailer Brake Controller is located in the center stack below the climate controls.

This module will have four different options depending on the type of trailer you want to tow and can be selected through the 3.5" Electronic Vehicle Information Center (EVIC) or touchscreen radio.

- Light Electric
- Heavy Electric
- Light EOH (Electric Over Hydraulic)
- Heavy EOH (Electric Over Hydraulic)

Setting with the Uconnect® Touchscreen Radio To make the proper selection in the Uconnect® touchscreen radio, press the More hard-key (Uconnect® 5.0) or the Apps soft-key (Uconnect® 8.4), then press the Settings soft-key to display the menu setting screen and press trailer brake. For additional information, refer to your Owner's Manual on the DVD.

Setting with a 3.5" EVIC

1. Press the RIGHT arrow on the steering wheel to enter "VEHICLE SETTINGS."
2. Press the UP or DOWN buttons until Trailer Brake Type appears on the screen.
3. Press the RIGHT arrow and then press the UP or DOWN buttons until the proper Trailer Brake Type appears on the screen. For additional information, refer to your Owner's Manual on the DVD.

GAIN Adjustment Buttons (+/-)

- Pressing the +/- buttons, located on the left side of the module, will increase/decrease the brake control power output to the trailer brakes in 0.5 increments. The GAIN setting can be increased to a maximum of 10 or decreased to a minimum of 0 (no trailer braking).

Refer to your Owner's Manual on the DVD for further details.



- 1 — Decrease (-)
2 — Increase (+)

WARNING!

Connecting a trailer that is not compatible with the ITBM system may result in reduced or complete loss of trailer braking. There may be an increase in stopping distance or trailer instability which could result in personal injury.

RECREATIONAL TOWING (BEHIND MOTORHOME, ETC.)

Towing This Vehicle Behind Another Vehicle

Towing Condition	Wheels OFF The Ground	Two-Wheel Drive Models	Four-Wheel Drive Models
Flat Tow	NONE	NOT ALLOWED	See Instructions <ul style="list-style-type: none"> Automatic transmission in PARK Manual transmission in gear (NOT in NEUTRAL) Transfer case in NEUTRAL (N) Tow in forward direction
Dolly Tow	Front	NOT ALLOWED	NOT ALLOWED
	Rear	OK	NOT ALLOWED
On Trailer	ALL	OK	OK

NOTE:

- When recreationally towing your vehicle, always follow applicable state and provincial laws. Contact state and provincial Highway Safety offices for additional details.
- Vehicles equipped with air suspension must be placed in Transport mode before tying them down (from the body) on a trailer or flatbed truck. Refer to “Air Suspension – If Equipped” for more information. If the vehicle cannot be placed in Transport mode (for example, engine will not run), tie-downs must be fastened to the axles (not to the body). Failure to follow these instructions may cause fault codes to be set and/or cause loss of proper tie-down tension.

Recreational Towing — Two-Wheel Drive Models

DO NOT flat tow this vehicle. Damage to the drivetrain will result.

Recreational towing (for two-wheel drive models) is allowed **ONLY** if the rear wheels are **OFF** the ground. This may be accomplished using a tow dolly or vehicle trailer. If using a tow dolly, follow this procedure:

1. Properly secure the dolly to the tow vehicle, following the dolly manufacturer's instructions.

NOTE:

If vehicle is equipped with air suspension, ensure the vehicle is set to Normal Ride Height.

2. Drive the rear wheels onto the tow dolly.
3. Firmly apply the parking brake. Place automatic transmission in PARK, manual transmission in gear (not in NEUTRAL).
4. Properly secure the rear wheels to the dolly, following the dolly manufacturer's instructions.
5. Turn the ignition switch to the OFF position and remove the Key Fob.
6. Install a suitable clamping device, designed for towing, to secure the front wheels in the straight position.

CAUTION!

- Towing with the rear wheels on the ground will cause severe transmission damage. Damage from improper towing is not covered under the New Vehicle Limited Warranty.
- Do not disconnect the driveshaft because fluid may leak from the transmission, causing damage to internal parts.

Recreational Towing — Four-Wheel Drive Models

NOTE:

Both the manual shift and electronic shift transfer cases must be shifted into NEUTRAL (N) for recreational towing. Automatic transmissions must be shifted into PARK for recreational towing. Manual transmissions must be placed in gear (NOT in NEUTRAL) for recreational towing. Refer to the following for the proper transfer case NEUTRAL (N) shifting procedure for your vehicle.

CAUTION!

- Front or rear wheel lifts should not be used while recreational towing. Towing with only one set of wheels on the ground (front or rear) will cause severe damage to the transmission and or transfer case. Tow with all four wheels either **ON** the ground, or **OFF** the ground (using a vehicle trailer). Damage from improper towing is not covered under the New Vehicle Limited Warranty.
- Do not disconnect the driveshaft because fluid may leak from the transmission, causing damage to internal parts.
- Front or rear wheel lifts should not be used. Internal damage to the transmission or transfer case will occur if a front or rear wheel lift is used when recreational towing.
- Tow only in the forward direction. Towing this vehicle backwards can cause severe damage to the transfer case.
- Before recreational towing, the transfer case must be in NEUTRAL. To be certain the transfer case is fully in NEUTRAL, perform the procedure outlined under “Shifting Into NEUTRAL”. Internal transmission damage will result, if the transfer case is not in NEUTRAL during towing.
- Manual transmissions must be placed in gear (not in Neutral) for recreational towing.
- Before recreational towing, perform the procedure outlined under “Shifting Into NEUTRAL” to be certain that the transfer case is fully in NEUTRAL. Otherwise, internal damage will result.
- Towing this vehicle in violation of the above requirements can cause severe transmission and/or transfer case damage. Damage from improper towing is not covered under the New Vehicle Limited Warranty.
- Do not disconnect the rear driveshaft because fluid will leak from the transfer case, causing damage to internal parts.
- Do not use a bumper-mounted clamp-on tow bar on your vehicle. The bumper face bar will be damaged.

Shifting Into NEUTRAL (N)

Use the following procedure to prepare your vehicle for recreational towing.

WARNING!

You or others could be injured or killed if you leave the vehicle unattended with the transfer case in the NEUTRAL (N) position without first fully engaging the parking brake. The transfer case NEUTRAL (N) position disengages both the front and rear driveshafts from the powertrain and will allow the vehicle to roll, even if the transmission is in PARK. The parking brake should always be applied when the driver is not in the vehicle.

CAUTION!

It is necessary to follow these steps to be certain that the transfer case is fully in NEUTRAL (N) before recreational towing to prevent damage to internal parts.

1. Bring the vehicle to a complete stop, with the engine running. Firmly apply the parking brake.
2. Shift the transmission to NEUTRAL.

NOTE:

If vehicle is equipped with air suspension, ensure the vehicle is set to Normal Ride Height.

3. Press and hold the brake pedal.
4. Depress the clutch pedal on a manual transmission.
 - With manual shift transfer case, shift the transfer case lever into NEUTRAL (N).
 - With electronic shift transfer case, press and hold the transfer case NEUTRAL (N) button. Some models have a small, recessed "N" button (at the center of the transfer case switches) that must be pressed using a ballpoint pen or similar object. Other models have a rectangular NEUTRAL switch, below the rotary transfer case control knob. The NEUTRAL (N) indicator light will blink while the shift is in progress. The light will stop blinking (stay on solid) when the shift to NEUTRAL (N) is complete. After the shift is completed and the NEUTRAL (N) light stays on, release the NEUTRAL (N) button.
5. Release the parking brake.
6. Shift the transmission into REVERSE.
7. Release the brake pedal (and clutch pedal on manual transmissions) for five seconds and ensure that there is no vehicle movement.
8. Repeat steps 6 and 7 with automatic transmission in DRIVE or manual transmission in first gear.

9. Shift the transmission to NEUTRAL. Firmly apply the parking brake. Turn OFF the engine. For vehicles with Keyless Enter-N-Go™, press and hold the ENGINE START/STOP button until the engine shuts off.
10. Shift the transmission into PARK or place manual transmission in gear (NOT in Neutral). On 8-speed transmissions the shifter will automatically select PARK when the engine is turned off.
11. Turn the ignition switch to the OFF position, then cycle the key or the Keyless Enter-N-Go™ button to the RUN position and back to the OFF position. Remove the key fob from the ignition switch.
12. Attach the vehicle to the tow vehicle using a suitable tow bar.
13. Release the parking brake.

NOTE:

With electronic shift transfer case:

- Steps 2 through 4 are requirements that must be met before pressing the NEUTRAL (N) button, and must continue to be met until the shift has been completed. If any of these requirements are not met before pressing the NEUTRAL (N) button or are no longer met during the shift, the NEUTRAL (N) indicator light will flash continuously until all requirements are met or until the NEUTRAL (N) button is released.
- The ignition switch must be in the ON/RUN position for a shift to take place and for the position indicator lights to be operable. If the ignition switch is not in the ON/RUN position, the shift will not take place and no position indicator lights will be on or flashing.
- A flashing NEUTRAL (N) position indicator light indicates that shift requirements have not been met.
- If the vehicle is equipped with air suspension, the engine should be started and left running for a minimum of 60 seconds (with all the doors closed) at least once every 24 hours. This process allows the air suspension to adjust the vehicle's ride height to compensate for temperature effects.

Shifting Out Of NEUTRAL (N)

Use the following procedure to prepare your vehicle for normal usage.

1. Bring the vehicle to a complete stop, leaving it connected to the tow vehicle.
2. Firmly apply the parking brake.
3. Press and hold the brake pedal.
4. Start the engine. Shift the transmission into NEUTRAL. Depress the clutch pedal on a manual transmission.
 - With manual shift transfer case, shift the transfer case lever to the desired position.

- With electronic shift transfer case with rotary selector switch, press and hold the transfer case NEUTRAL (N) button until the NEUTRAL (N) indicator light turns off. After the NEUTRAL (N) indicator light turns off, release the NEUTRAL (N) button. After the NEUTRAL (N) button has been released, the transfer case will shift to the position indicated by the selector switch.
- With electronic shift transfer case with pushbutton selector switch, press and hold the switch for the desired transfer case position, until the NEUTRAL (N) indicator light turns off and the desired position indicator light turns on.

NOTE:

When shifting out of transfer case NEUTRAL (N), turning the engine OFF is not required, but may be helpful to avoid gear clash. With the 8-speed automatic transmission, the engine must remain running, since turning the engine OFF will shift the transmission to PARK (and the transmission must be in NEUTRAL for the transfer case to shift out of NEUTRAL).

5. Turn the engine OFF. Shift automatic transmission into PARK. On 8-speed transmissions the shifter will automatically select PARK when the engine is turned off.
6. Release the brake pedal (and clutch pedal on a manual transmission).
7. Disconnect vehicle from the tow vehicle.
8. Start the engine.
9. Press and hold the brake pedal.
10. Release the parking brake.
11. Shift the transmission into gear, release the brake pedal (and clutch pedal on manual transmissions), and check that the vehicle operates normally.

NOTE:

With electronic shift transfer case:

- Steps 3 and 4 are requirements that must be met before pressing the button to shift out of NEUTRAL (N), and must continue to be met until the shift has been completed. If any of these requirements are not met before pressing the button or are no longer met during the shift, the NEUTRAL (N) indicator light will flash continuously until all requirements are met or until the button is released.
- The ignition switch must be in the ON/RUN position for a shift to take place and for the position indicator lights to be operable. If the ignition switch is not in the ON/RUN position, the shift will not take place and no position indicator lights will be on or flashing.
- A flashing NEUTRAL (N) position indicator light indicates that shift requirements have not been met.

1500 3.0L DIESEL

DIESEL ENGINE BREAK-IN RECOMMENDATIONS

- The 3.0 turbocharged diesel engine does not require a break-in period due to its construction. Normal operation is allowed, providing the following recommendations are followed:
 - Warm up the engine before placing it under load.
 - Do not operate the engine at idle for prolonged periods.
 - Use the appropriate transmission gear to prevent engine lugging.
 - Observe vehicle oil pressure and temperature indicators.
 - Check the coolant and oil levels frequently.
 - Vary throttle position at highway speeds when carrying or towing significant weight.

NOTE:

Light duty operation such as light trailer towing or no load operation will extend the time before the engine is at full efficiency. Reduced fuel economy and power may be seen at this time.

- The engine oil installed in the engine at the factory is a high-quality energy conserving type lubricant. Oil changes should be consistent with anticipated climate conditions under which vehicle operations will occur. The recommended viscosity and quality grades are shown under "FLUIDS AND CAPACITIES", under "MAINTAINING YOUR VEHICLE" in this User Guide. NON-DETERGENT OR STRAIGHT MINERAL OILS MUST NEVER BE USED.

DIESEL ENGINE STARTING PROCEDURES

Normal Starting Procedure

1. Apply the parking brake.
2. Ensure the shift lever is in the PARK position.
3. Press and hold the brake pedal while pressing the ENGINE START/STOP button once and the system will engage the starter to crank the engine.

NOTE:

- A delay of the start of up to five seconds is possible under very cold conditions. The "Wait to Start" telltale will be illuminated during the pre-heat process. When the engine Wait To Start light goes off the engine will automatically crank.
 - If you wish to stop the cranking of the engine prior to the engine starting, press the button again.
4. Check that the oil pressure warning light has turned off.
 5. Release the parking brake.

CAUTION!

If the “Water in Fuel Indicator Light” remains on, DO NOT START the engine before you drain the water from the fuel filters to avoid engine damage. Refer to “Maintenance Procedures/Draining Fuel/Water Separator Filter” in “Maintaining Your Vehicle” in your Diesel Supplement on the DVD for further information.

Extreme Cold Weather

The engine block heater is a resistance heater installed in the water jacket of the engine. It requires a 110–115 Volt AC electrical outlet with a grounded, three-wire extension cord.

Its use is recommended for environments that routinely fall below -10°F. It should be used when the vehicle has not been running overnight or longer periods and should be plugged in two hours prior to start. Its use is required for cold starts with temperatures under -20°F.

A 12 Volt heater built into the fuel filter housing aids in preventing fuel gelling. It is controlled by a built-in thermostat.

A Diesel Pre-Heat system both improves engine starting and reduces the amount of white smoke generated by a warming engine.

NOTE:

The engine block heater cord is a factory installed option. If your vehicle is not equipped, heater cords are available from your authorized MOPAR® dealer.

Water In Fuel Message

If a Water In Fuel message or  indicator appears in the cluster and a chime sounds five times, the fuel/water separator will need to be drained immediately to prevent engine damage.

Refer to “Draining Fuel Water Separator” in this guide for draining instructions or see your dealer.

1500 3.0L DIESEL

DIESEL FUEL FILTER/WATER SEPARATOR

Draining Fuel/Water Separator

If the “Water in Fuel” indicator light  is illuminated and an audible chime is heard five times, you should stop the engine and drain the water from the separator.

The drain plug is located on the bottom of the Fuel Filter and Water Separator assembly which is located above the rear axle next to the fuel tank.

Loosen the drain plug (located on the bottom filter assembly) then turn the ignition switch to the ON/RUN position to allow any accumulated water to drain.

When clean fuel is visible, close the drain and switch the ignition to the OFF position.

Refer to the Diesel Supplement on the DVD for further details.

Fuel Filter Replacement

1. Ensure engine is turned off.
2. Place drain pan under the fuel filter assembly.
3. Open the water drain valve, and let any accumulated water drain.
4. Close the water drain valve.
5. Remove bottom cover using a strap wrench. Rotate counterclockwise for removal. Remove the used o-ring and discard it.
6. Remove the used filter cartridge from the housing and dispose of according to your local regulations.
7. Wipe the sealing surfaces of the lid and housing clean.
8. Install new o-ring back into ring groove on the filter housing and lubricate with clean engine oil.

NOTE:

The WIF (Water In Fuel) sensor is re-usable. Service kit comes with new o-ring for filter canister and WIF (Water In Fuel) sensor.

CAUTION!

- Diesel fuel will damage blacktop paving surfaces. Drain the filter into an appropriate container.
- Do not prefill the fuel filter when installing a new fuel filter. There is a possibility debris could be introduced into the fuel filter during this action. It is best to install the filter dry and allow the in-tank lift pump to prime the fuel system.
- If the “Water In Fuel Indicator Light” remains on, DO NOT START the engine before you drain water from the fuel filter to avoid engine damage.

EXHAUST REGENERATION

This engine meets all required EPA diesel engine emissions standards. To achieve these emissions standards, your vehicle is equipped with a state-of-the-art engine and exhaust system. These systems are seamlessly integrated into your vehicle and managed by the Powertrain Control Module (PCM). Additionally, your vehicle has the ability to alert you to additional maintenance required on your vehicle or engine. Refer to the following messages that may be displayed on your Driver Information Display (DID).

Exhaust System — Regeneration Required Now

This message indicates that the Diesel Particulate Filter (DPF) reached 80% of its maximum storage capacity.

By simply driving your vehicle at highway speeds for up to 20 minutes, you can remedy the condition in the particulate filter system and allow your diesel engine and exhaust after-treatment system to cleanse the filter to remove the trapped PM and restore the system to normal operating condition.

Exhaust System — Regeneration in Process Exhaust Filter XX% Full

Indicates that the Diesel Particulate Filter (DPF) is self-cleaning. Maintain your current driving condition until regeneration is completed.

Exhaust System — Regeneration Completed

This message indicates that the Diesel Particulate Filter (DPF) self-cleaning is completed. If this message is displayed, you will hear one chime to assist in alerting you of this condition.

Exhaust Service Required — See Dealer Now

This message indicates regeneration has been disabled due to a system malfunction. The Powertrain control Module (PCM) will register a fault code and the instrument panel will display the Malfunction Indicator Light (MIL).

CAUTION!
See your authorized dealer, as damage to the exhaust system could occur soon with continued operation.

1500 3.0L DIESEL

Exhaust Filter Full — Power Reduced See Dealer

The PCM derates the engine in order to limit the likelihood of permanent damage to the after-treatment system. If this condition is not corrected and a dealer service is not performed, extensive exhaust after-treatment damage can occur. Have your vehicle serviced by your local authorized dealer.

NOTE:

Failing to follow the oil change indicator, changing your oil and resetting the oil change indicator by 0 miles remaining will prevent the diesel exhaust filter from performing its cleaning routine. This will shortly result in a Malfunction Indicator Light (MIL) and reduced engine power. Only an authorized dealer will be able to correct this condition.

CAUTION!

See your authorized dealer, as damage to the exhaust system could occur with the exhaust filter full.

COOL-DOWN IDLE CHART

TURBO "COOL DOWN" CHART			
Driving Conditions	Load	Turbo Temp	Idle Time (in minutes) Before Shut Down
Stop and Go	Empty	Cool	Less than 1
Stop and Go	Medium	Warm	1
Highway Speeds	Medium	Warm	2
City Traffic	Max. GCWR	Warm	3
Highway Speeds	Max. GCWR	Warm	4
Uphill Grade	Max. GCWR	Hot	5

ADDING FUEL — DIESEL ENGINE ONLY

Your vehicle is equipped with a cap-less fuel system.

Most fuel cans will not open the flapper door.

A funnel is provided to open the flapper door to allow emergency refueling with a fuel can.

Emergency Fuel Can Refueling

1. Retrieve funnel from the jack storage area under the passenger seat.
2. Insert the funnel into same filler pipe opening as the fuel nozzle.
3. Ensure the funnel is inserted fully to hold flapper door open.
4. Pour fuel into funnel opening.
5. Remove the funnel from filler pipe, clean off prior to putting back in the jack storage area under the passenger seat.

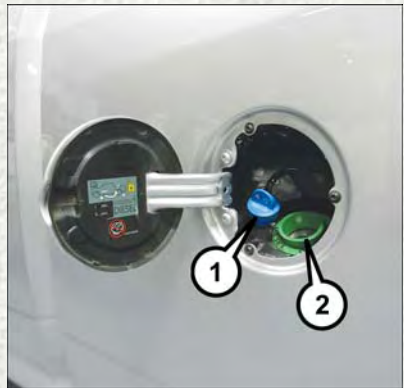

1 — Diesel Exhaust Fluid (DEF) Fill Location

2 — Diesel Fuel Fill Location

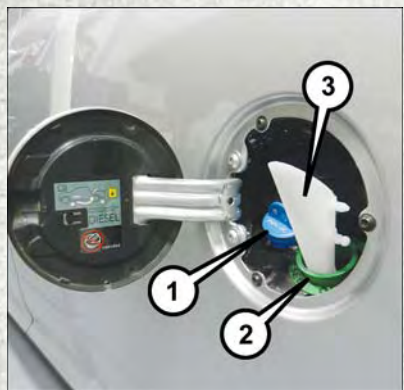

1 — Diesel Exhaust Fluid (DEF) Fill Location

2 — Diesel Fuel Fill Location

3 — Emergency Diesel Fuel Fill Funnel

1500 3.0L DIESEL

DIESEL EXHAUST FLUID

Diesel Exhaust Fluid (DEF) sometimes known simply by the name of its active component, UREA – is a key component of selective catalytic reduction (SCR) systems, which help diesel vehicles meet stringent emission regulations. DEF is a liquid reducing agent that reacts with engine exhaust in the presence of a catalyst to convert smog-forming nitrogen oxides (NOx) into harmless nitrogen and water vapor.

Your vehicle is equipped with a Selective Catalytic Reduction system in order to meet the very stringent diesel emissions standards required by the Environmental Protection Agency. Selective Catalytic Reduction (SCR) is the first and only technology in decades to be as good for the environment as it is good for business and vehicle performance.

The purpose of the SCR system is to reduce levels of NOx (oxides of nitrogen emitted from engines) that are harmful to our health and the environment to an almost near-zero level. Small quantities of Diesel Exhaust Fluid (DEF) are injected into the exhaust upstream of a catalyst where, when vaporized, convert smog-forming nitrogen oxides (NOx) into harmless nitrogen (N₂) and water vapor (H₂O), two natural components of the air we breathe. You can operate with the comfort that your vehicle is contributing to a cleaner, healthier world environment for this and generations to come.

System Overview

This vehicle is equipped with a Diesel Exhaust Fluid (DEF) injection system and a Selective Catalytic Reduction (SCR) catalyst to meet the emission requirements.

The DEF injection system consists of the following components:

- DEF tank
- DEF pump
- DEF injector
- Electronically-heated DEF lines
- NOx sensors
- Temperature sensors
- SCR catalyst

The DEF injection system and SCR catalyst enable the achievement of diesel emissions requirements; while maintaining outstanding fuel economy, drivability, torque and power ratings.

NOTE:

- Your vehicle is equipped with a DEF injection system. You may occasionally hear an audible clicking noise. This is normal operation.
- The DEF pump will run for a period of time after engine shutdown to purge the DEF system. This is normal operation.

Adding Diesel Exhaust Fluid

The DEF gauge (located in the instrument panel) will display the level of DEF remaining in the tank.

Completely fill the DEF tank through the diesel exhaust fluid fill location (located behind the fuel door) at every maintenance interval or before if prompted by the Electronic Vehicle Information Center (EVIC)/Driver Information Display (DID).

NOTE:

- Driving conditions (altitude, vehicle speed, load, etc.) will effect the amount of DEF that is used in your vehicle.
- Since DEF will begin to freeze at 12°F (-11°C), your vehicle is equipped with an automatic DEF heating system. This allows the DEF injection system to operate properly at temperatures below 12°F (-11°C). If your vehicle is not in operation for an extended period of time with temperatures below 12°F (-11°C), the DEF in the tank may freeze. If the tank is overfilled and freezes, it could be damaged. Therefore, do not overfill the DEF tank. Extra care should be taken when filling with portable containers to avoid overfilling. Note the level of the DEF gauge in your instrument cluster. On pickup applications, you may safely add a maximum of 2 gallons of DEF from portable containers when your DEF gauge is reading ½ full.

DEF Fill Procedure

1. Remove cap from DEF tank (located behind the fuel door on drivers side of the vehicle).
2. Insert DEF container or fill nozzle into DEF fill location and fill DEF tank.

NOTE:

- The DEF gauge may take up to five seconds to update after adding a gallon or more of Diesel Exhaust Fluid (DEF) to the DEF tank. If you have a fault related to the DEF system, the gauge may not update to the new level. See your authorized dealer for service.
- The DEF gauge may also not immediately update after a refill if the temperature of the DEF fluid is below 12F (-11C). The DEF line heater will possibly warm up the DEF fluid and allow the gauge to update after a period of run time. Under very cold conditions, it is possible that the gauge may not reflect the new fill level for several drives.

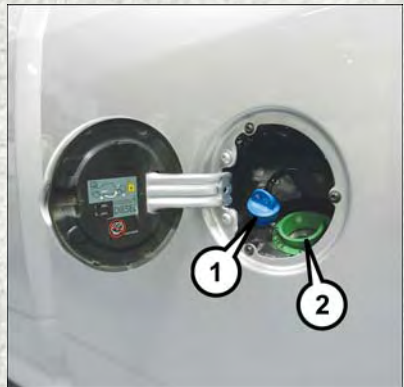

1 — Diesel Exhaust Fluid (DEF) Fill Location

2 — Diesel Fuel Fill Location

1500 3.0L DIESEL

3. Reinstall cap onto DEF tank.

Refer to your Diesel Supplement on the DVD for further details.

CAUTION!

- To avoid DEF spillage and overfilling, do not “top off” the DEF tank after filling.
- When DEF is spilled, clean the area immediately with water or a mild solvent.
- DO NOT OVERFILL. DEF will freeze below 12 degrees F (-11 degrees C). The DEF system is designed to work in temperatures below the DEF freezing point, however, if the tank is overfilled and freezes, the system could be damaged.

Diesel Exhaust Fluid (DEF) Warning Messages

Your vehicle will begin displaying warning messages when the DEF level reaches a driving range of approximately 500 miles (800 km).

If the following warning message sequence is ignored, your vehicle may not restart unless DEF is added within the displayed mileage shown in the DID message.

Engine Will Not Restart in XXXX mi DEF Low Refill Soon – This message will display when DEF driving range is less than 500 miles, DEF fluid top off is required with in the displayed mileage. The message will be displayed in the DID during vehicle start up with the current allowed mileage and accompanied by a single chime. The remaining mileage can be pulled up anytime by way of the “Messages” list within the DID.

Engine Will Not Restart in XXXX mi Refill DEF – This message will display when DEF driving range is less than 200 miles. It is also displayed at 150 miles and 100 miles. DEF fluid top off is required with in the displayed mileage. The message will be displayed in the DID during vehicle start up with an updated distance mileage, and it will be accompanied by a single chime. Stating at 100 miles, remaining range will be continuously displayed while operating the vehicle. Chimes will also accompany the 75, 50 and 25 mile remaining distances. The DEF Low telltale will be on continuously until DEF fluid is topped off.

Engine Will Not Restart Refill DEF – This message will display when the DEF driving range is less than 1 mile, DEF fluid top off is required or the engine will not restart. The message will be displayed in the DID during vehicle start up, and it will be accompanied by a single chime. The DEF Low telltale will be illuminated continuously until DEF fluid tank is filled with a minimum of two gallons of DEF.

Diesel Exhaust Fluid (DEF) Fault Warning Messages

There are different messages which are displayed if the vehicle detects that the DEF system has been filled with a fluid other than DEF, has experienced component failures, or when tampering has been detected.

When the DEF system needs to be serviced the following warnings will display:

Service DEF System See Dealer – This message will display when the fault is initially detected and each time the vehicle is started. The message will be accompanied by a single chime and the Malfunction Indicator Light. We recommend you drive to your nearest authorized dealer and have your vehicle serviced immediately. If not corrected in 50 miles, vehicle will enter the “Engine Will not restart in XXXmi Service DEF See dealer” warning stage and message.

Incorrect DEF Detected See Dealer – This message will display if the DEF system has detected the incorrect fluid has been introduced to the DEF tank. The message will be accompanied by a single chime. We recommend you drive to your nearest authorized dealer and have your vehicle serviced immediately. If not corrected in 50 miles, vehicle will enter the Engine Will not restart in XXX mi Service DEF See dealer warning stage and message.

Engine Will Not Restart in XXX mi Service DEF See Dealer – This message is first displayed if the fault detected is not serviced after 50 miles of operation. It is also displayed at 150 miles 125 miles and 100 miles. System service is required within the displayed mileage. The message will be displayed in the DID during vehicle start up with an updated distance mileage, and it will be accompanied by a single chime. Starting at 100 miles, remaining range will be continuously displayed while operating the vehicle. Chimes will also accompany the 75, 50 and 25 mile remaining distances. We recommend you drive to your nearest authorized dealer and have your vehicle serviced immediately.

Engine Will Not Restart Service DEF System See Dealer – This message will display if the DEF system issue detected is not serviced during the allowed period. Your engine will not restart unless your vehicle is serviced by your authorized dealer. This message will be displayed when under 1 mile until the engine will not start and each time the vehicle is started. The message will be continuously displayed and be accompanied by a single chime. Your Malfunction Indicator Light will also be continuously illuminated. We highly recommend you drive to your nearest authorized dealer immediately if the message appears while engine is running.

Engine Will Not Start Service DEF System See Dealer – This message will display when the fault detected is not serviced after the Engine will not restart Service DEF System See Dealer message is displayed on the next subsequent restart. Your engine will not start unless you vehicle is serviced by your authorized dealer. The message will be accompanied by a single chime. Your Malfunction Indicator Light will be continuously illuminated. If the message appears and you can not start the engine, we recommend you have your vehicle towed to your nearest authorized dealer immediately.

6.7L CUMMINS® DIESEL

DIESEL ENGINE BREAK-IN RECOMMENDATIONS

The Cummins® turbocharged diesel engine does not require a break-in period due to its construction. Normal operation is allowed, providing the following recommendations are followed:

- Warm up the engine before placing it under load.
- Do not operate the engine at idle for prolonged periods.
- Use the appropriate transmission gear to prevent engine lugging.
- Observe vehicle oil pressure and temperature indicators.
- Check the coolant and oil levels frequently.
- Vary throttle position at highway speeds when carrying or towing significant weight.

NOTE:

Light duty operation such as light trailer towing or no load operation will extend the time before the engine is at full efficiency. Reduced fuel economy and power may be seen at this time.

Because of the construction of the Cummins® turbocharged diesel engine, engine run-in is enhanced by loaded operating conditions which allow the engine parts to achieve final finish and fit during the first 6,000 miles (10 000 km).

DIESEL ENGINE STARTING PROCEDURES

Engine Block Heater

For ambient temperatures below 0°F (-18°C), engine block heater usage is recommended.

For ambient temperatures below -20°F (-29°C), engine block heater usage is required.

The engine block heater cord is routed under the hood to the right side and can be located just behind the grille near the headlamp.

Connect the heater cord to a ground-fault interrupter protected 110–115 volt AC electrical outlet with a grounded, three-wire extension cord.

NOTE:

The block heater will require 110 volts AC and 6.5 amps to activate the heater element.

The block heater must be plugged in at least one hour to have an adequate warming effect on the coolant.

Water In Fuel Message

If a Water In Fuel message or  indicator appears in the cluster and a chime sounds five times, the fuel/water separator will need to be drained immediately to prevent engine damage.

Refer to “Draining Fuel Water Separator” in this guide for draining instructions or see your dealer.

Cold Start Procedure

Turn the ignition switch to the ON position. If the Wait To Start  light appears in the cluster, wait for the light to turn off before starting.

In extremely cold weather below 0°F (-18°C) it may be beneficial to cycle the manifold heaters twice before attempting to start the engine. This can be accomplished by turning the ignition OFF for at least five seconds and then back ON after the “Wait To Start Light” has turned off, but before the engine is started. However, excessive cycling of the manifold heaters will result in damage to the heater elements or reduced battery voltage.

Refer to the Owner's Manual Diesel Supplement on the DVD for further details.

Engine Idling

Avoid prolonged engine idling. Long periods of idling may be harmful to your engine because combustion chamber temperatures can drop so low that the fuel may not burn completely.

Incomplete combustion allows carbon and varnish to form on piston rings, engine valves, and injector nozzles. Also, the unburned fuel can enter the crankcase, diluting the oil and causing rapid wear to the engine.

If the engine is allowed to idle, under some conditions the idle speed may increase to 900 RPM then return to normal idle speed. This is normal operation.

WARNING!

Remember to disconnect the cord before driving. Damage to the 110–115 volt electrical cord could cause electrocution.

6.7L CUMMINS® DIESEL

DIESEL EXHAUST BRAKE (ENGINE BRAKING)

The Exhaust Brake switch is located on the switch bank below the audio system. This switch is used to enable exhaust brake modes.

Pressing the exhaust brake switch once will enable full strength exhaust brake mode, indicated by a yellow icon in the EVIC/DID. This mode applies full exhaust braking when the accelerator pedal is released. This is most useful for slowing the vehicle.

Pressing the exhaust brake switch again will enable the Smart Brake feature, indicated by a green icon in the EVIC/DID. This feature is intended to maintain the vehicle speed present when the accelerator pedal is released. However, when the brakes are applied, full exhaust braking is still enabled to slow the vehicle.

A third press of the brake switch will turn the exhaust brake off, and will extinguish the exhaust brake icon in the EVIC/DID.

NOTE:

In general, higher engine speeds result in higher exhaust braking force. For optimum braking power, it is recommended to use the exhaust brake while in TOW/HAUL mode.

CAUTION!

Use of aftermarket exhaust brakes is not recommended and could lead to engine damage.

WARNING!

Do not use the exhaust brake feature when driving in icy or slippery conditions as the increased engine braking can cause the rear wheels to slide and the vehicle to swing around with the possible loss of vehicle control, which may cause a collision possibly resulting in personal injury or death.

IDLE-UP FEATURE (AUTOMATIC TRANSMISSION ONLY)



Speed Control Switches

- 1 — Push CANCEL
- 2 — Push ON/OFF
- 3 — Push Resume/Accel
- 4 — Push Set/Decel

The Idle-Up Feature uses the speed control switches to increase engine idle speed and quickly warm the vehicle's interior. This feature must be enabled by your dealer. See your local dealer.

With the transmission in PARK, the parking brake applied, and the engine running, push the speed control ON/OFF switch on, then push the SET switch.

The engine RPM will go up to 1100 RPM. To increase the RPM, push and hold the RESUME/ACCEL switch and the idle speed will increase to approximately 1500 RPM. To decrease the RPM, push and hold the SET/DECEL switch and the idle speed will decrease to approximately 1100 RPM.

To cancel the Idle Up Feature, either push the CANCEL switch, push the ON/OFF switch or push the brake pedal.

6.7L CUMMINS® DIESEL

ENGINE MOUNTED FUEL FILTER/WATER SEPARATOR

Draining Fuel/Water Separator

If the “Water in Fuel” indicator light  is illuminated and an audible chime is heard five times, you should stop the engine and drain the water from the separator.

The drain is located on the bottom of the Fuel Filter and Water Separator assembly which is located on the driver's side of the engine.

Turn the drain valve (located on the side of the filter) counterclockwise 1/4 turn, then turn the ignition switch to the ON/RUN position to allow any accumulated water to drain.

When clean fuel is visible, close the drain and switch the ignition to OFF.

Refer to the Diesel Supplement on the DVD for further details.

Fuel Filter Replacement

1. With the engine off and a drain pan under the fuel filter drain hose, open the water drain valve 1/4 turn counterclockwise and completely drain fuel and water into the approved container.
2. Close the water drain valve and remove the lid using a socket or strap wrench; rotate counterclockwise for removal. Remove the used o-ring and discard it.
3. Remove the used filter cartridge from the housing and dispose of according to your local regulations.
4. Wipe clean the sealing surfaces of the lid and housing and install the new o-ring into ring groove on the filter housing and lubricate with clean engine oil.
5. Install a new filter in the housing. Push down on the cartridge to ensure it is properly seated. **Do not pre-fill the filter housing with fuel.**
6. Install the lid onto the housing and tighten to 22.5 ft lbs (30.5 N-m). Do not overtighten the lid.
7. Start the engine and confirm no leaks are present.

The engine mounted filter housing is equipped with a No-Filter-No-Run (NFNR) feature. Engine will not run if:

- No filter is installed.
- Inferior/Non-approved filter is used. Use of OEM filter is required to ensure vehicle will run.

CAUTION!

- Diesel fuel will damage blacktop paving surfaces. Drain the filter into an appropriate container.
- Do not prefill the fuel filter when installing a new fuel filter. There is a possibility debris could be introduced into the fuel filter during this action. It is best to install the filter dry and allow the in-tank lift pump to prime the fuel system.
- If the “Water In Fuel Indicator Light” remains on, DO NOT START the engine before you drain water from the fuel filter to avoid engine damage.

UNDERBODY MOUNTED FUEL FILTER/WATER SEPARATOR

Draining Fuel/Water Separator

If the “Water in Fuel” indicator light  is illuminated and an audible chime is heard five times, you should stop the engine and drain the water from the separator.

The drain is located on the bottom of the Fuel Filter and Water Separator assembly which is located in front of the rear axle above the drive shaft on pick up models. The Chassis Cab models second filter location is on the frame behind the front axle. The best access to this water drain valve is from under the vehicle.

- Turn the drain valve (located on the side of the filter) counterclockwise 1 full turn, then turn the ignition switch to the ON/RUN position to allow any accumulated water to drain.
- When clean fuel is visible, close the drain and switch the ignition to OFF.
- Refer to the Diesel Supplement on the DVD for further details.

Underbody Fuel Filter Replacement

1. With the engine off and a drain pan under the fuel filter drain hose, open the water drain valve 1 full turn counterclockwise and completely drain fuel and water into the approved container.
2. Close the water drain valve and remove the lid using a socket or strap wrench; rotate counterclockwise for removal. Remove the used o-ring and discard it.
3. Remove the used filter cartridge from the housing and dispose of according to your local regulations.
4. Wipe clean the sealing surfaces of the lid and housing and install the new o-ring into ring groove on the filter housing and lubricate with clean engine oil.
5. Install a new filter in the housing. Push down on the cartridge to ensure it is properly seated. **Do not pre-fill the filter housing with fuel.**
6. Start the engine and confirm no leaks are present.

6.7L CUMMINS® DIESEL

The underbody mounted filter housing will cause the engine not to run if:

- No filter is installed.

NOTE:

- Using a fuel filter that does not meet the manufacturer's filtration and water separating requirements can severely impact fuel system life and reliability.
- The WIF sensor is re-usable. Service kit comes with new o-ring for filter canister and WIF sensor.

CAUTION!

- Diesel fuel will damage blacktop paving surfaces. Drain the filter into an appropriate container.
- Do not prefill the fuel filter when installing a new fuel filter. There is a possibility debris could be introduced into the fuel filter during this action. It is best to install the filter dry and allow the in-tank lift pump to prime the fuel system.
- If the “Water In Fuel Indicator Light” remains on, DO NOT START the engine before you drain water from the fuel filter to avoid engine damage.

EXHAUST REGENERATION

Under certain conditions, your Cummins® diesel engine and exhaust after-treatment system may never reach the conditions required to remove the trapped particulate matter. If this occurs, the “Exhaust System — Regeneration Required Now” message will be displayed on the EVIC/DID screen in your cluster and you will hear one chime to alert you of this condition. Driving your vehicle at highway speeds for as little as 45 minutes can remedy the condition and allow the engine and exhaust after-treatment system to remove the trapped particulate matter.

NOTE:

Under typical operating conditions, NO indications of regeneration state will be displayed. If you do reach 80% of filter capacity, the following messages will assist you in inducing and understanding the regeneration process.

Perform Service

Your vehicle will require emissions maintenance at a set interval. To help remind you when this maintenance is due, the Electronic Vehicle Information Center (EVIC)/ Driver Information Display (DID) will display “Perform Service”. When the “Perform Service” message is displayed on the EVIC/DID it is necessary to have the emissions maintenance performed. Emissions maintenance may include replacing the Closed Crankcase Ventilation (CCV) filter element, and cleaning of the EGR Cooler. The procedure for clearing and resetting the “Perform Service” indicator message is located in the appropriate Service Information.

Exhaust System — Regeneration Required Now

“Exhaust System—Regeneration Required Now” will be displayed on the EVIC/DID if the exhaust particulate filter reaches 80% of its maximum storage capacity.

Exhaust Filter XX% Full

Indicates that the Diesel Particulate Filter (DPF) is approaching full.

Exhaust System — Regeneration in Process Exhaust Filter XX% Full

Indicates that the Diesel Particulate Filter (DPF) is self-cleaning. Maintain your current driving condition until regeneration is completed.

Exhaust System — Regeneration Completed

This message indicates that the Diesel Particulate Filter (DPF) self-cleaning is completed. If this message is displayed, you will hear one chime to assist in alerting you of this condition.

Exhaust Service Required — See Dealer Now

This message indicates regeneration has been disabled due to a system malfunction. The Powertrain control Module (PCM) will register a fault code and the instrument panel will display the Malfunction Indicator Light (MIL).

CAUTION!

See your authorized dealer, as damage to the exhaust system could occur soon with continued operation.

Exhaust Filter Full — Power Reduced See Dealer

The PCM derates the engine in order to limit the likelihood of permanent damage to the after-treatment system. If this condition is not corrected and a dealer service is not performed, extensive exhaust after-treatment damage can occur. Have your vehicle serviced by your local authorized dealer.

NOTE:

Failing to follow the oil change indicator, changing your oil and resetting the oil change indicator by 0 miles remaining will prevent the diesel exhaust filter from performing its cleaning routine. This will shortly result in a Malfunction Indicator Light (MIL) and reduced engine power. Only an authorized dealer will be able to correct this condition.

CAUTION!

See your authorized dealer, as damage to the exhaust system could occur with the exhaust filter full.

6.7L CUMMINS® DIESEL

COOL-DOWN IDLE CHART

TURBO "COOL DOWN" CHART			
Driving Conditions	Load	Turbo Temp	Idle Time (in minutes) Before Shut Down
Stop and Go	Empty	Cool	Less than 1
Stop and Go	Medium	Warm	1
Highway Speeds	Medium	Warm	2
City Traffic	Max. GCWR	Warm	3
Highway Speeds	Max. GCWR	Warm	4
Uphill Grade	Max. GCWR	Hot	5

ADDING FUEL — DIESEL ENGINE ONLY

Your vehicle is equipped with a cap-less fuel system.

Most fuel cans will not open the flapper door.

A funnel is provided to open the flapper door to allow emergency refueling with a fuel can.

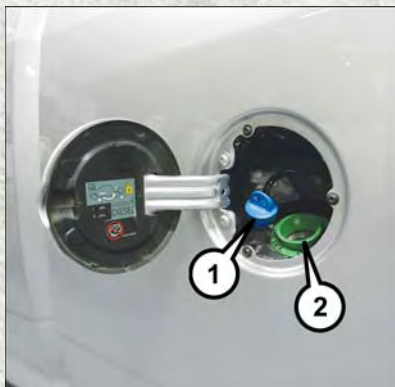

1 — Diesel Exhaust Fluid (DEF) Fill Location

2 — Diesel Fuel Fill Location

Emergency Fuel Can Refueling

1. Retrieve funnel from the jack storage area under the passenger seat.
2. Insert the funnel into same filler pipe opening as the fuel nozzle.
3. Ensure the funnel is inserted fully to hold flapper door open.
4. Pour fuel into funnel opening.
5. Remove the funnel from filler pipe, clean off prior to putting back in the jack storage area under the passenger seat.

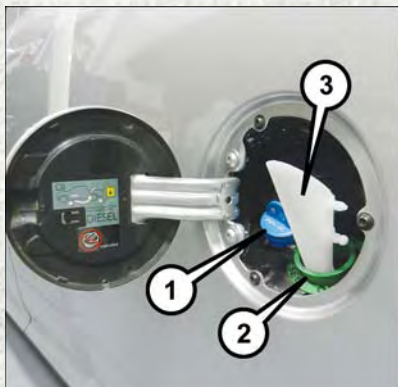

- 1 — Diesel Exhaust Fluid (DEF) Fill Location
2 — Diesel Fuel Fill Location
3 — Emergency Diesel Fuel Fill Funnel

DIESEL EXHAUST FLUID

Diesel Exhaust Fluid (DEF) sometimes known simply by the name of its active component, UREA – is a key component of selective catalytic reduction (SCR) systems, which help diesel vehicles meet stringent emission regulations. DEF is a liquid reducing agent that reacts with engine exhaust in the presence of a catalyst to convert smog-forming nitrogen oxides (NOx) into harmless nitrogen and water vapor.

Your vehicle is equipped with a Selective Catalytic Reduction system in order to meet the very stringent diesel emissions standards required by the Environmental Protection Agency. Selective Catalytic Reduction (SCR) is the first and only technology in decades to be as good for the environment as it is good for business and vehicle performance.

6.7L CUMMINS® DIESEL

The purpose of the SCR system is to reduce levels of NOx (oxides of nitrogen emitted from engines) that are harmful to our health and the environment to an almost near-zero level. Small quantities of Diesel Exhaust Fluid (DEF) are injected into the exhaust upstream of a catalyst where, when vaporized, convert smog-forming nitrogen oxides (NOx) into harmless nitrogen (N₂) and water vapor (H₂O), two natural components of the air we breathe. You can operate with the comfort that your vehicle is contributing to a cleaner, healthier world environment for this and generations to come.

System Overview

This vehicle is equipped with a Diesel Exhaust Fluid (DEF) injection system and a Selective Catalytic Reduction (SCR) catalyst to meet the emission requirements.

The DEF injection system consists of the following components:

- DEF tank
- DEF pump
- DEF injector
- Electronically-heated DEF lines
- DEF control module
- NOx sensors
- NH₃ sensor
- Temperature sensors
- SCR catalyst

The DEF injection system and SCR catalyst enable the achievement of diesel emissions requirements; while maintaining outstanding fuel economy, drivability, torque and power ratings.

NOTE:

- Your vehicle is equipped with a DEF injection system. You may occasionally hear an audible clicking noise. This is normal operation.
- The DEF pump will run for a period of time after engine shutdown to purge the DEF system. This is normal operation.

Diesel Exhaust Fluid Storage

Diesel Exhaust Fluid (DEF) is considered a very stable product with a long shelf life. If DEF is kept in temperatures between 10° to 90°F (-12° to 32°C), it will last a minimum of one year.

DEF is subject to freezing at the lowest temperatures. For example, DEF may freeze at temperatures at or below 12° F (-11° C). The system has been designed to operate in this environment.

NOTE:

When working with DEF, it is important to know that:

Any containers or parts that come into contact with DEF must be DEF compatible (plastic or stainless steel). Copper, brass, aluminum, iron or non-stainless steel should be avoided as they are subject to corrosion by DEF.

If DEF is spilled, it should be wiped up completely.

Adding Diesel Exhaust Fluid

The DEF gauge (located in the instrument cluster) will display the level of DEF remaining in the tank.

Completely fill the DEF tank through the diesel exhaust fluid fill location at every maintenance interval or before if prompted by the Electronic Vehicle Information Center (EVIC)/Driver Information Display (DID).

NOTE:

- Driving conditions (altitude, vehicle speed, load, etc.) will effect the amount of DEF that is used in your vehicle.
- Since DEF will begin to freeze at 12°F (-11°C), your vehicle is equipped with an automatic DEF heating system. This allows the DEF injection system to operate properly at temperatures below 12°F (-11°C). If your vehicle is not in operation for an extended period of time with temperatures below 12°F (-11°C), the DEF in the tank may freeze. If the tank is overfilled and freezes, it could be damaged. Therefore, do not overfill the DEF tank. Extra care should be taken when filling with portable containers to avoid overfilling. Note the level of the DEF gauge in your instrument cluster. On pickup applications, you may safely add a maximum of 2 gallons of DEF from portable containers when your DEF gauge is reading ½ full. On Chassis Cab applications a maximum of 2 gallons may be added when the DEF gauge is reading ¾ full.

6.7L CUMMINS® DIESEL

DEF Fill Procedure

1. Remove cap from DEF tank (located behind the fuel door on drivers side of the vehicle).
2. Insert DEF container or fill nozzle into DEF fill location and fill DEF tank.
3. Reinstall cap onto DEF tank.

Refer to your Diesel Supplement on the DVD for further details.

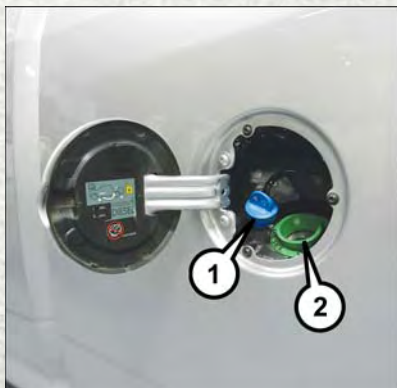

- 1 — Diesel Exhaust Fluid (DEF) Fill Location
2 — Diesel Fuel Fill Location

CAUTION!

- To avoid DEF spillage and overfilling, do not “top off” the DEF tank after filling.
- When DEF is spilled, clean the area immediately with water or a mild solvent.
- DO NOT OVERFILL. DEF will freeze below 12 degrees F (-11 degrees C). The DEF system is designed to work in temperatures below the DEF freezing point, however, if the tank is overfilled and freezes, the system could be damaged.

Diesel Exhaust Fluid (DEF) Warning Messages

Your vehicle will begin displaying warning messages when the DEF level reaches a driving range of approximately 350 miles (563 km). If the following warning message sequence is ignored, your vehicle may be limited to a maximum speed of 5 MPH (8 km/H) unless DEF is added.

DEF Low Refill Soon — This message will display when the low level is reached, during vehicle start up, and with increased frequency during vehicle operation. It will be accompanied by a single chime. Approximately 5 gallons (19 Liters) of DEF is required to refill the tank when this message is initially displayed on pickup applications, and approximately 7 gallons (28 Liters) are required on chassis-cab applications.

Speed Limited to 5 MPH in XXX mi Refill DEF — This message will continuously display if the “DEF Low Refill Soon” message is ignored, and the frequency of occurrence of the chime will increase unless up to 2 gallons (7.5 Liters) of DEF is added to the tank.

5 MPH Max Speed on Restart, Long Idle or Refuel Refill DEF — This message will continuously display when the counter reaches zero, and will be accompanied by a periodic chime.

The vehicle will only be capable of a maximum speed of 5 MPH upon the first of the following conditions to occur:

- If the vehicle is shutoff and restarted.
- If the vehicle is idled for an extended period of time, approximately one hour or greater.
- If the system detects that the level of fuel in the tank has increased.

Add a minimum of 2 gallons (7.5 Liters) of DEF to the tank in order to avoid vehicle operation at a maximum speed of 5 MPH (8 km/H).

5 MPH Max Speed Refill DEF — The vehicle will only be capable of a maximum speed of 5 MPH (8 km/H) when this message is displayed. Add up to 2.5 gallons (7.5 Liters) of DEF to the tank to restore normal vehicle operation.

NOTE:

A minimum of 2 gallons (7.5 Liters) may be required to restore normal vehicle operation. Although the vehicle will start normally and can be placed in gear after this message has been initially displayed, extreme caution should be utilized since the vehicle will only be capable of maneuvering at a maximum speed of 5 MPH (8 km/H).

Diesel Exhaust Fluid (DEF) Fault Warning Messages

There are four different messages which are displayed if the vehicle detects that the DEF system has been filled with a fluid other than DEF, has experienced component failures, or when tampering has been detected. The vehicle may be limited to a maximum speed of 5 MPH (8 km/H) if the DEF system is not serviced within less than 250 miles (402 km) of the fault being detected.

When the DEF system needs to be serviced the following warnings will display:

Service DEF System – See Dealer — This message will display when the fault is initially detected, each time the vehicle is started, and periodically during driving. The message will be accompanied by a single chime. We recommend you drive to your nearest authorized dealer and have your vehicle serviced as soon as possible.

5 MPH Max Speed in 150 mi Service DEF System See Dealer — This message will display if the DEF system has not been serviced after the “Service DEF System – See Dealer” message is displayed. This message will continuously display until the mileage counter reaches zero, and will be accompanied by a periodic chime. The message will continue to countdown until it reaches zero unless the vehicle is serviced. We recommend you drive to your nearest authorized dealer and have your vehicle serviced immediately.

NOTE:

Under some circumstances this mileage counter may start with a value of less than 150 miles (241 km). For example, if recurring faults are detected in a time interval of less than 40 hours, the counter may restart at the value where it stopped when a previous fault was temporarily remedied, or at a minimum of 50 miles (80 km).

5 MPH Max Speed on Restart, Long Idle or Refuel Service DEF See Dealer — This message will continuously display when the mileage counter reaches zero, and will be accompanied by a periodic chime.

The vehicle will only be capable of a maximum speed of 5 MPH upon the first of the following conditions to occur:

- If the vehicle is shutoff and restarted.
- If the vehicle is idled for an extended period of time, approximately one hour or greater.
- If the system detects that the level of fuel in the tank has increased.

5 MPH Max Speed Service DEF System See Dealer — This message will continuously display, and will be accompanied by a periodic chime. Although the vehicle can be started and placed in gear, the vehicle will only operate at a maximum speed of 5 MPH. Your vehicle will require towing, see your authorized dealer for service.

NOTE:

When this message is displayed, the engine can still be started. However, the vehicle will only operate at a maximum speed of 5 MPH.

WHAT TO DO IN EMERGENCIES

ROADSIDE ASSISTANCE

Dial toll-free 1-800-521-2779 for U.S. Residents or 1-800-363-4869 for Canadian Residents.

- Provide your name, vehicle identification number, license plate number, and your location, including the telephone number from which you are calling.
- Briefly describe the nature of the problem and answer a few simple questions.
- You will be given the name of the service provider and an estimated time of arrival. If you feel you are in an “unsafe situation”, please let us know. With your consent, we will contact local police or safety authorities.

INSTRUMENT CLUSTER WARNING LIGHTS

- Electronic Stability Control (ESC) Activation/Malfunction Indicator Light

If this indicator light flashes during acceleration, apply as little throttle as possible. While driving, ease up on the accelerator. Adapt your speed and driving to the prevailing road conditions. To improve the vehicle's traction when starting off in deep snow, sand or gravel, it may be desirable to switch the ESC system off.

- Tire Pressure Monitoring System (TPMS) Light

Each tire, including the spare (if provided), should be checked monthly, when cold and inflated to the inflation pressure recommended by the vehicle manufacturer on the vehicle placard or tire inflation pressure label. (If your vehicle has tires of a different size than the size indicated on the vehicle placard or tire inflation pressure label, you should determine the proper tire inflation pressure for those tires.)

IF THE LIGHT STARTS FLASHING INDICATING A LOW TIRE PRESSURE, ADJUST THE AIR PRESSURE IN THE LOW TIRE TO THE AIR PRESSURE SHOWN ON THE VEHICLE PLACARD OR TIRE INFLATION PRESSURE LABEL LOCATED ON THE DRIVER'S DOOR.

NOTE:

After inflation, the vehicle may need to be driven for 20 minutes before the flashing light will turn off.

Your vehicle has also been equipped with a TPMS malfunction indicator to indicate when the system is not operating properly. The TPMS malfunction indicator is combined with the low tire pressure telltale. When the system detects a malfunction, the telltale will flash for approximately one minute and then remain continuously illuminated. This sequence will continue each time the vehicle is restarted as long as the malfunction exists.

WHAT TO DO IN EMERGENCIES

When the malfunction indicator is illuminated, the system may not be able to detect or signal low tire pressure as intended. TPMS malfunctions may occur for a variety of reasons, including the installation of replacement or alternate tires or wheels on the vehicle that prevent the TPMS from functioning properly. Always check the TPMS malfunction telltale after replacing one or more tires or wheels on your vehicle, to ensure that the replacement or alternate tires and wheels allow the TPMS to continue to function properly.

NOTE:

Tire pressures change by approximately 1 psi (7 kPa) per 12° F (7° C) of air temperature change. Keep this in mind when checking tire pressure inside a garage, especially in the Winter. Example: If garage temperature is 68°F (20°C) and the outside temperature is 32°F (0°C), then the cold tire inflation pressure should be increased by 3 psi (21 kPa), which equals 1 psi (7 kPa) for every 12°F (7°C) for this outside temperature condition.

CAUTION!

The TPMS has been optimized for the original equipment tires and wheels. TPMS pressures and warning have been established for the tire size equipped on your vehicle. Undesirable system operation or sensor damage may result when using replacement equipment that is not of the same size, type, and/or style. Aftermarket wheels can cause sensor damage. Do not use tire sealant from a can, or balance beads if your vehicle is equipped with a TPMS, as damage to the sensors may result.

- Engine Temperature Warning Light

This light warns of an overheated engine condition.

If the light turns on and a warning chime sounds while driving, safely pull over and stop the vehicle. If the A/C system is on, turn it off. Also, shift the transmission into NEUTRAL and idle the vehicle. If the temperature reading does not return to normal, turn the engine off immediately.

We recommend that you do not operate the vehicle or engine damage will occur. Have the vehicle serviced immediately.

WARNING!

A hot engine cooling system is dangerous. You or others could be badly burned by steam or boiling coolant.

WHAT TO DO IN EMERGENCIES

BRAKE - Brake Warning Light

This light monitors various brake functions, including brake fluid level and parking brake application. If the brake light turns on it may indicate that the parking brake is applied, that the brake fluid level is low, or that there is a problem with the anti-lock brake system reservoir.

If the light remains on when the parking brake has been disengaged, and the fluid level is at the full mark on the master cylinder reservoir, it indicates a possible brake hydraulic system malfunction or that a problem with the Brake Booster has been detected by the Anti-Lock Brake System (ABS)/Electronic Stability Control (ESC) system. In this case, the light will remain on until the condition has been corrected. If the problem is related to the brake booster, the ABS pump will run when applying the brake and a brake pedal pulsation may be felt during each stop.

The dual brake system provides a reserve braking capacity in the event of a failure to a portion of the hydraulic system. A leak in either half of the dual brake system is indicated by the Brake Warning Light, which will turn on when the brake fluid level in the master cylinder has dropped below a specified level. The light will remain on until the cause is corrected.

Vehicles equipped with the Anti-Lock Brake System (ABS), are also equipped with Electronic Brake Force Distribution (EBD). In the event of an EBD failure, the Brake Warning Light will turn on along with the ABS Light. Immediate repair to the ABS system is required.

Operation of the Brake Warning Light can be checked by turning the ignition switch from the OFF position to the ON/RUN position. The light should illuminate for approximately two seconds. The light should then turn off unless the parking brake is applied or a brake fault is detected. If the light does not illuminate, have the light inspected by an authorized dealer.

The light also will turn on when the parking brake is applied with the ignition switch in the ON/RUN position.

NOTE:

This light shows only that the parking brake is applied. It does not show the degree of brake application.

WARNING!

Driving a vehicle with the red brake light on is dangerous. Part of the brake system may have failed. It will take longer to stop the vehicle. You could have a collision. Have the vehicle checked immediately.

WHAT TO DO IN EMERGENCIES

- Malfunction Indicator Light (MIL)

The Malfunction Indicator Light (MIL) is part of an onboard diagnostic system called OBD II that monitors engine and automatic transmission control systems. The light will illuminate when the key is in the ON/RUN position before engine start. If the bulb does not come on when turning the key from OFF to ON/RUN, have the condition checked promptly.

Certain conditions, poor fuel quality, etc., may illuminate the light after engine start. The vehicle should be serviced if the light stays on through several of your typical driving cycles. In most situations, the vehicle will drive normally and will not require towing.

CAUTION!

Prolonged driving with the Malfunction Indicator Light (MIL) on could cause damage to the engine control system. It also could affect fuel economy and driveability. If the MIL is flashing, severe catalytic converter damage and power loss will soon occur. Immediate service is required.

WARNING!

A malfunctioning catalytic converter, as referenced above, can reach higher temperatures than in normal operating conditions. This can cause a fire if you drive slowly or park over flammable substances such as dry plants, wood, cardboard, etc. This could result in death or serious injury to the driver, occupants or others.

- Electronic Stability Control (ESC) OFF Indicator Light

The ESC OFF indicator will illuminate when the Electronic Stability Control (ESC) is turned off.

- Charging System Light

This light shows the status of the electrical charging system. If the charging system light remains on, it means that the vehicle is experiencing a problem with the charging system.

We recommend you do not continue driving if the charging system light is on. Have the vehicle serviced immediately.

- Oil Pressure Warning Light

This light indicates low engine oil pressure. If the light turns on while driving, stop the vehicle and shut off the engine as soon as possible. A chime will sound for four minutes when this light turns on.

We recommend you do not operate the vehicle or engine damage will occur. Have the vehicle serviced immediately.

WHAT TO DO IN EMERGENCIES

- Anti-Lock Brake (ABS) Light

This light monitors the Anti-Lock Brake System (ABS). The light will turn on when the ignition switch is turned to the ON/RUN position and may stay on for as long as four seconds.

If the ABS light remains on or turns on while driving, it indicates that the Anti-Lock portion of the brake system is not functioning and that service is required. However, the conventional brake system will continue to operate normally if the BRAKE warning light is not on.

If the ABS light is on, the brake system should be serviced as soon as possible to restore the benefits of Anti-Lock brakes. If the ABS light does not turn on when the ignition switch is turned to the ON/RUN position, have the light inspected by an authorized dealer.

- Electronic Throttle Control (ETC) Light

This light informs you of a problem with the Electronic Throttle Control (ETC) system.

If a problem is detected, the light will come on while the engine is running. Cycle the ignition when the vehicle has completely stopped and the shift lever is placed in the PARK position; the light should turn off.

If the light remains lit with the engine running, your vehicle will usually be drivable; however, see an authorized service center immediately. If the light is flashing when the engine is running, immediate service is required and you may experience reduced performance, an elevated/rough idle or engine stall and your vehicle may require towing.

- Air Bag Warning Light

This light will turn on for four to eight seconds as a bulb check when the ignition switch is first turned to the ON/RUN position. If the light is either not on during starting, stays on, or turns on while driving, have the system inspected at an authorized dealer as soon as possible. Refer to “Occupant Restraints” in “Things To Know Before Starting Your Vehicle” of your Owner’s Manual for further information.

NOTE:

The Air Bag System is designed to be maintenance free.

- SERV (Service) 4WD Indicator Light

The SERV 4WD light monitors the electric shift four-wheel drive system. If the SERV 4WD light stays on or comes on during driving, it means that the four-wheel drive system is not functioning properly and that service is required.

For vehicles equipped with a premium cluster this indicator will display in the Driver Information Display (DID).

WHAT TO DO IN EMERGENCIES

- Transmission Temperature Warning Light

This light indicates that there is excessive transmission fluid temperature that might occur with severe usage such as trailer towing. If this light turns on, stop the vehicle and run the engine at idle, with the transmission in NEUTRAL, until the light turns off. Once the light turns off, you may continue to drive normally.

CAUTION!

Continuous driving with the Transmission Temperature Warning Light illuminated will eventually cause severe transmission damage or transmission failure.

WARNING!

If you continue operating the vehicle when the Transmission Temperature Warning Light is illuminated you could cause the fluid to boil over, come in contact with hot engine or exhaust components and cause a fire.

Oil Change Indicator

Message

If an “oil change” message (shown as “Change Oil Soon” and “Oil Change Needed”) appears and a single chime sounds, it is time for your next required oil change.

Resetting The Light After Servicing

1. Turn the ignition switch to the ON/RUN position (do not start engine).
2. Fully depress the accelerator pedal three times within 10 seconds.
3. Turn the ignition switch to the OFF/LOCK position.

- Low Coolant Level Indicator Light

This light indicates low coolant level. If the light turns on while driving, stop the vehicle and shut off the engine as soon as possible.

We recommend you do not operate the vehicle or engine damage will occur. Have the vehicle serviced immediately.

WHAT TO DO IN EMERGENCIES

INSTRUMENT CLUSTER INDICATOR LIGHTS

- Turn Signal Indicator

The arrows will flash with the exterior turn signals when the turn signal lever is operated. A tone will chime, and a EVIC/DID message will appear if either turn signal is left on for more than 1 mile (1.6 km).

NOTE:

If either indicator flashes at a rapid rate, check for a defective outside light bulb.

- High Beam Indicator

Indicates that headlights are on high beam.

- Park/Headlight ON Indicator

This indicator will illuminate when the park lights or headlights are turned on.

- Front Fog Light Indicator

This indicator will illuminate when the front fog lights are on.

- Vehicle Security Light

This light will flash rapidly for approximately 15 seconds when the vehicle security alarm is arming. The light will flash at a slower speed continuously after the alarm is set. The security light will also come on for about three seconds when the ignition is first turned on.

— Tow/Haul Mode

Indicates that the Tow/Haul Mode is active.

— Four Wheel Drive Auto

Indicates that the Four Wheel Drive has engaged automatically.

— Electronic Stability Control OFF

This light indicates the ESC system has been turned off by the driver.

— Cargo Light

Indicates that the rear cargo light is on.

— Door Ajar

Indicates that one of the vehicles doors is open.

WHAT TO DO IN EMERGENCIES

— Electronic Speed Control Set

Indicates that the Electronic Speed Control has been set.

- Fuel Cap/Loose Gas Cap Message

If a “gas cap” message appears, tighten the gas cap until a “clicking” sound is heard. Press the odometer reset button to turn the message off.

If the message continues to appear for more than three days after tightening the gas cap, see your authorized service center.

IF YOUR ENGINE OVERHEATS

In any of the following situations, you can reduce the potential for overheating by taking the appropriate action:

- On the highways — slow down.
- In city traffic — while stopped, shift the transmission to NEUTRAL, but do not increase engine idle speed.

NOTE:

There are steps that you can take to slow down an impending overheat condition:

- If your air conditioner (A/C) is on, turn it off. The A/C system adds heat to the engine cooling system and turning the A/C off can help remove this heat.
- You can also turn the temperature control to maximum heat, the mode control to floor and the blower control to high. This allows the heater core to act as a supplement to the radiator and aids in removing heat from the engine cooling system.

CAUTION!

Driving with a hot cooling system could damage your vehicle. If the temperature gauge reads HOT (H), pull over and stop the vehicle. Idle the vehicle with the air conditioner turned off until the pointer drops back into the normal range. If the pointer remains on HOT (H), and you hear continuous chimes, turn the engine off immediately, and call for service.

WARNING!

You or others can be badly burned by hot engine coolant (antifreeze) or steam from your radiator. If you see or hear steam coming from under the hood, do not open the hood until the radiator has had time to cool. Never try to open a cooling system pressure cap when the radiator or coolant bottle is hot.

WHAT TO DO IN EMERGENCIES

JACKING AND TIRE CHANGING

Jack Location

The jack and jack tools are stored under the front passenger seat.

Removal Of Jack And Tools

- To access the jack and jack tools you must remove the plastic access cover, located on the side of the seat. To remove the cover, pull the front part of the cover (closest to the front of the seat) toward you to release a locking tab. Once the front of the cover is loose, slide the cover toward the front of the seat until it is free from the seat frame.



Jack And Tools Location

1500 Series Trucks

- Remove the jack and tool bag by removing the wing bolt and sliding the jack and tool bag from under the seat.



Wing Bolt Location

WHAT TO DO IN EMERGENCIES

2500/3500 Series Trucks

- Remove the jack and tool bracket assembly by removing the wing bolt and sliding the jack and tool bracket assembly from under the seat.



Jack And Tool Bracket Assembly

Removing The Spare Tire

- Remove the spare tire before attempting to jack up the truck. Attach the wheel wrench to the jack extension tube. Insert the tube through the access hole between the lower tailgate and the top of the bumper and into the winch mechanism tube. Rotate the wheel wrench handle counterclockwise until the spare tire is on the ground with enough cable slack to allow you to pull it out from under the vehicle. When the spare is clear, tilt the retainer at the end of the cable and pull it through the center of the wheel.

NOTE:

Always stow the spare tire with the valve stem facing the ground.

- It is recommended that you stow the flat or spare to avoid tangling the loose cable.

NOTE:

The winch mechanism is designed for use with the jack extension tube only. Use of an air wrench or other power tools is not recommended and can damage the winch.

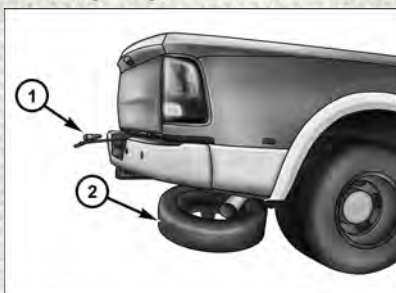

Wheel Wrench/Spare Tire

1 — Wheel
Wrench

2 — Spare Tire

WHAT TO DO IN EMERGENCIES

Preparations

1. Park the vehicle on a firm, level surface. Avoid ice or slippery areas.
 2. Turn on the Hazard Warning flasher.
 3. Set the parking brake.
 4. Place the shift lever into PARK. On four-wheel drive vehicles, shift the transfer case to the 4L position.
 5. Turn the ignition OFF.
- Block both the front and rear of the wheel diagonally opposite the jacking position. For example, if the right front wheel is being changed, block the left rear wheel.

NOTE:

Passengers should not remain in the vehicle when the vehicle is being jacked.



Wheel Blocked

Instructions

1. Remove the spare wheel, jack, and tools from storage.
2. Using the wheel wrench, loosen, but do not remove, the wheel nuts by turning them counterclockwise one turn while the wheel is still on the ground.



Warning Label

WHAT TO DO IN EMERGENCIES

3. Placement of the jack:

1500 Series Trucks

- When changing a front wheel, place the scissors jack under the rear portion of the lower control arm as shown below.



Front 4x2 Jacking Location



Front 4x4 Jacking Location

WHAT TO DO IN EMERGENCIES

- Operate the jack using the jack drive tube and the wheel wrench. The tube extension may be used but is not required.
- **For 4x2 and 4x4 trucks**, when changing a rear wheel, assemble the jack drive tube to the jack and connect the drive tube to the extension tube. Place the jack under the axle between the wheel and the shock bracket with the drive tubes extending to the rear.



Rear 4x4 Jacking Location

- Connect the jack tube extension and wheel wrench.

WHAT TO DO IN EMERGENCIES

2500/3500 Series Trucks

- For 2500/3500 4x2 series trucks, when changing a front wheel, place the bottle jack under the frame rail behind the wheel. Locate the jack as far forward as possible on the straight part of the frame.



Jacking Location

- Operate the jack using the jack drive tube and the wheel wrench. The tube extension, may be used, but is not required.

WHAT TO DO IN EMERGENCIES

- **For 2500/3500 4x4 series trucks**, when changing the front wheel, assemble the jack drive tube to the jack and connect the drive tube to the extension tube. Place the jack under the axle as close to the tire as possible with the drive tubes extending to the front. Connect the jack tube extension and wheel wrench.
- **For 4x2 and 4x4 trucks**, when changing a rear wheel, assemble the jack drive tube to the jack and connect the drive tube to the extension tube. Place the jack under the axle between the spring and the shock absorber with the drive tubes extending to the rear.
- Connect the jack tube extension and wheel wrench.

NOTE:

If the bottle jack will not lower by turning the dial (thumbwheel) by hand, it may be necessary to use the jack drive tube in order to lower the jack.

- By rotating the wheel wrench clockwise, raise the vehicle until the wheel just clears the surface.
- Remove the wheel nuts and pull the wheel off. On single rear-wheel (SRW) trucks, install the spare wheel and wheel nuts with the cone shaped end of the wheel nuts toward the wheel. On 3500 dual rear-wheel models (DRW) the wheel nuts are a two-piece assembly with a flat face. Lightly tighten the wheel nuts. To avoid the risk of forcing the vehicle off the jack, do not fully tighten the wheel nuts until the vehicle has been lowered.



Front Jacking Location



Rear Jacking Location

WHAT TO DO IN EMERGENCIES

- Using the lug wrench, finish tightening the wheel nuts using a crisscross pattern. The correct wheel nut tightness is 130 ft lbs (176 N·m) torque (1500 Series), 135 ft lbs (183 N·m) torque for 2500/3500 single-rear wheel (SRW) models, and 140 ft lbs (190 N·m) for 3500 dual rear-wheel models. If in doubt about the correct tightness, have them checked with a torque wrench by your authorized dealer or at a service station.
- Install the wheel center cap and remove the wheel blocks. Do not install chrome or aluminum wheel center caps on the spare wheel. This may result in cap damage.
- Lower the jack to its fully closed position. If the bottle jack will not lower by turning the dial (thumbwheel) by hand, it may be necessary to use the jack drive tube in order to lower the jack. Stow the replaced tire, jack, and tools as previously described.
- Adjust the tire pressure when possible.

NOTE:

Do not oil wheel studs. For chrome wheels, do not substitute with chrome plated wheel nuts.

Reinstalling The Jack And Tools

1500 Series Trucks

1. Tighten the jack all the way down by turning the jack turn-screw clockwise until the jack is snug.
2. Position the jack and tool bag. Make sure the lug wrench is under the jack near the jack turn-screw.
3. Secure the tool bag straps to the jack.



Jack And Tool Bag

WHAT TO DO IN EMERGENCIES

4. Place the jack and tools in the storage position holding the jack by the jack turn-screw, slip the jack and tools under the seat so that the bottom slot engages into the fastener on the floor.

NOTE:

Ensure that the jack slides into the front hold down location.



Floor Fastener Location

5. Turn the wing bolt clockwise to secure to the floor pan. Reinstall the plastic cover.



Wing Bolt Location

WHAT TO DO IN EMERGENCIES

2500/3500 Series Trucks

1. Tighten the jack all the way down by turning the jack turn-screw clockwise until the jack is snug.
2. Position the jack and tools into bracket assembly. Make sure the lug wrench is under the jack near the jack turn-screw. Snap tools into bracket assembly clips. Install the jack into bracket assembly and turn screw until jack is snug into bracket assembly.
3. Place the jack and tool bracket assembly in the storage position holding the jack by the jack turn-screw, slip the jack and tools under the seat so that the bottom slot engages into the fastener on the floor.

NOTE:

Ensure that the jack and tool bracket assembly slides into the front hold down location.

4. Turn the wing bolt clockwise to secure to the floor pan. Reinstall the plastic cover.



Floor Fastener Location

Hub Caps/Wheel Covers

- The hub caps must be removed before raising the vehicle off the ground.
- For single rear-wheel (SRW) models, use the blade on the end of the lug wrench to pry the hub cap off. Insert the blade end into the pry-off notch and carefully pop off the hub cap with a back-and-forth motion.
- On models with dual rear wheels (DRW), you must first remove the hub caps. The jack handle driver has a hook at one end that will fit in the pry off notch of the rear hub caps. Position the hook and pull out on the ratchet firmly. The hub cap should pop off. The wheel skins can now be removed. For the front hub cap use the blade on the end of the lug wrench to pry the caps off. The wheel skin can now be removed.
- You must use the flat end of the lug wrench to pry off the wheel skins. Insert the flat tip completely and using a back-and-forth motion, loosen the wheel skin. Repeat this procedure around the tire until the skin pops off.
- Replace the wheel skins first using a rubber mallet. When replacing the hub caps, tilt the cap retainer over the lug nut bolt circle and strike the high side down with a rubber mallet. Be sure that the hub caps and wheel skins are firmly seated around the wheel.

WHAT TO DO IN EMERGENCIES

Wheel Nuts

All wheel nuts should be tightened occasionally to eliminate the possibility of wheel studs being sheared or the bolt holes in the wheels becoming elongated. This is especially important during the first few hundred miles/kilometers of operation to allow the wheel nuts to become properly set. All wheel nuts should first be firmly seated against the wheel. The wheel nuts should then be tightened to recommended torque. Tighten the wheel nuts to final torque in increments. Progress around the bolt circle, tightening the wheel nut opposite to the wheel nut just previously tightened until final torque is achieved. Recommended torques are shown in the following chart.

Disc Wheels

Nut Type	Stud Size	Hex Size	Torque Ft Lbs	Torque Newton Meters
Cone	M14 x 1.5	22 mm	130	176
Flanged	M14 x 1.5	22 mm	140	190

8-Stud — Dual Rear Wheels

- Dual wheels are flat-mounted and center-piloted. The lug nuts are a two-piece assembly. When the tires are being rotated or replaced, clean these lug nuts and add two drops of oil at the interface between the hex and the washer.
- Slots in the wheels will assist in properly orienting the inner and outer wheels. Align these slots when assembling the wheels for best access to the tire valve on the inner wheel. The tires of both dual wheels must be completely off the ground when tightening, to ensure wheel centering and maximum wheel clamping.
- Dual wheel models require a special heavy-duty lug nut tightening adapter (included with the vehicle) to correctly tighten the lug nuts. Also, when it is necessary to remove and install dual rear wheels, use a proper vehicle lifting device.

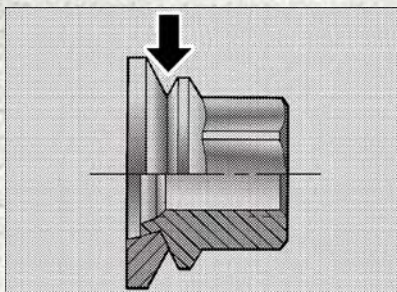

Oil Interface Location

NOTE:

When installing a spare tire as part of a dual rear wheel end combination, the tire diameter of the two individual tires must be compared. If there is a significant difference, the larger tire should be installed in a front location. The correct direction of rotation for dual tire installations must also be observed.

WHAT TO DO IN EMERGENCIES

These dual rear wheels should be tightened as follows:

1. Tighten the wheel nuts in the numbered sequence to a snug fit.
 2. Retighten the wheel nuts in the same sequence to the torques listed in the table. Go through the sequence a second time to verify that specific torque has been achieved. Retighten to specifications at 100 miles (160 km) and after 500 miles (800 km).
- It is recommended that wheel stud nuts be kept torqued to specifications at all times. Torque wheel stud nuts to specifications at each lubrication interval.

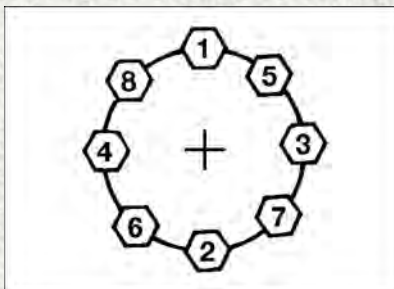

Wheel Nuts Numbered Sequence

To Stow The Flat Or Spare

NOTE:

RAM 1500 vehicles equipped with aluminum wheels cannot be stored under the vehicle because the wheel retainer will not fit through the wheel pilot hole. Secure the flat tire in the bed of the truck. Have the flat tire repaired or replaced immediately.

- Turn the wheel so that the valve stem is down. Slide the wheel retainer through the center of the wheel and position it properly across the wheel opening.
- For convenience in checking the spare tire inflation, stow with the valve stem toward the rear of the vehicle.
- Attach the wheel wrench to the extension tube. Rotate the winch mechanism until the wheel is drawn into place against the underside of the vehicle. Continue to rotate until you feel the winch mechanism slip, or click three or four times. It cannot be overtightened. Push against the tire several times to be sure it is firmly in place.

CAUTION!

- Do not attempt to raise the vehicle by jacking on locations other than those indicated in the Jacking Instructions for this vehicle.
- Before raising the wheel off the ground, make sure that the jack will not damage surrounding truck parts and adjust the jack position as required.
- Use a back and forth motion to remove the hub cap. Do not use a twisting motion when removing the hub cap, damage to the hub cap; finish may occur.
- The rear hub caps on the dual rear wheel has two pry off notches. Make sure that the hook of the jack handle driver is located squarely in the cap notch before attempting to pull off.

WHAT TO DO IN EMERGENCIES

WARNING!

- Do not attempt to change a tire on the side of the vehicle close to moving traffic. Pull far enough off the road to avoid the danger of being hit when operating the jack or changing the wheel.
- Being under a jacked-up vehicle is dangerous. The vehicle could slip off the jack and fall on you. You could be crushed. Never put any part of your body under a vehicle that is on a jack.
- Never start or run the engine while the vehicle is on a jack. If you need to get under a raised vehicle, take it to an authorized dealer where it can be raised on a lift.
- The jack is designed to be used as a tool for changing tires only. The jack should not be used to lift the vehicle for service purposes. The vehicle should be jacked on a firm level surface only. Avoid ice or slippery areas.
- Do not attempt to change a tire on the side of the vehicle close to moving traffic, pull far enough off the road to avoid the danger of being hit when operating the jack or changing the wheel.
- Carefully follow these tire changing warnings to help prevent personal injury or damage to your vehicle:
 - Always park on a firm, level surface as far from the edge of the roadway as possible before raising the vehicle.
 - Turn on the Hazard Warning flashers.
 - Block the wheel diagonally opposite the wheel to be raised.
 - Set the parking brake firmly and set an automatic transmission in PARK; a manual transmission in REVERSE.
 - Do not let anyone sit in the vehicle when it is on a jack.
 - Do not get under the vehicle when it is on a jack.
 - Only use the jack in the positions indicated and for lifting this vehicle during a tire change.
 - If working on or near a roadway, be extremely careful of motor traffic.
 - To assure that spare tires, flat or inflated, are securely stowed, spares must be stowed with the valve stem facing the ground.
 - Raising the vehicle higher than necessary can make the vehicle less stable. It could slip off the jack and hurt someone near it. Raise the vehicle only enough to remove the tire.
 - To avoid the risk of forcing the vehicle off the jack, do not fully tighten the wheel bolts until the vehicle has been lowered. Failure to follow this warning may result in personal injury.
 - To avoid possible personal injury, handle the wheel covers with care to avoid contact with any sharp edges.
 - A loose tire or jack thrown forward in a collision or hard stop could endanger the occupants of the vehicle. Always stow the jack parts and the spare tire in the places provided.
 - A loose tire thrown forward in a collision or hard stop could injure the occupants in the vehicle. Have the deflated (flat) tire repaired or replaced immediately.

WHAT TO DO IN EMERGENCIES

JUMP-STARTING PROCEDURES

If your vehicle has a discharged battery it can be jump-started using a set of jumper cables and a battery in another vehicle or by using a portable battery booster pack. Jump-starting can be dangerous if done improperly so please follow the procedures in this section carefully.

NOTE:

When using a portable battery booster pack follow the manufacturer's operating instructions and precautions.

CAUTION!

Do not use a portable battery booster pack or any other booster source with a system voltage greater than 12 Volts or damage to the battery, starter motor, alternator or electrical system may occur.

WARNING!

Do not attempt jump-starting if the battery is frozen. It could rupture or explode and cause personal injury.

Preparations For Jump-Start

The battery in your vehicle is located in the front of the engine compartment, behind the left headlight assembly.

NOTE:

The positive battery post is covered with a protective cap. Lift up on the cap to gain access to the positive battery post. Do not jump off fuses. Only jump directly off positive post.



Battery Positive Post

WHAT TO DO IN EMERGENCIES

WARNING!

- Take care to avoid the radiator cooling fan whenever the hood is raised. It can start anytime the ignition switch is ON. You can be injured by moving fan blades.
 - Remove any metal jewelry such as rings, watch bands and bracelets that could make an inadvertent electrical contact. You could be seriously injured.
 - Batteries contain sulfuric acid that can burn your skin or eyes and generate hydrogen gas which is flammable and explosive. Keep open flames or sparks away from the battery.
1. Set the parking brake, shift the automatic transmission into PARK and turn the ignition to LOCK.
 2. Turn off the heater, radio, and all unnecessary electrical accessories.
 3. If using another vehicle to jump-start the battery, park the vehicle within the jumper cables reach, set the parking brake and make sure the ignition is OFF.

WARNING!

Do not allow vehicles to touch each other as this could establish a ground connection and personal injury could result.

Jump-Starting Procedure

WARNING!

Failure to follow this jump-starting procedure could result in personal injury or property damage due to battery explosion.

CAUTION!

Failure to follow these procedures could result in damage to the charging system of the booster vehicle or the discharged vehicle.

Connecting The Jumper Cables

1. Connect the positive (+) end of the jumper cable to the positive (+) post of the discharged vehicle.

NOTE:

Do not jump off fuses. Only jump directly off positive post.

2. Connect the opposite end of the positive (+) jumper cable to the positive (+) post of the booster battery.
3. Connect the negative (-) end of the jumper cable to the negative (-) post of the booster battery.

WHAT TO DO IN EMERGENCIES

4. Connect the opposite end of the negative (-) jumper cable to a good engine ground (exposed metal part of the discharged vehicle's engine) away from the battery and the fuel injection system.

WARNING!

Do not connect the jumper cable to the negative (-) post of the discharged battery. The resulting electrical spark could cause the battery to explode and could result in personal injury. Only use the specific ground point, do not use any other exposed metal parts.

5. Start the engine in the vehicle that has the booster battery, let the engine idle a few minutes, and then start the engine in the vehicle with the discharged battery.

CAUTION!

Do not connect jumper cable to any of the fuses on the positive battery terminal. The resulting electrical current will blow the fuse.

6. Once the engine is started, remove the jumper cables in the reverse sequence:

Disconnecting The Jumper Cables

1. Disconnect the negative (-) end of the jumper cable from the engine ground of the vehicle with the discharged battery.
2. Disconnect the opposite end of the negative (-) jumper cable from the negative (-) post of the booster battery.
3. Disconnect the positive (+) end of the jumper cable from the positive (+) post of the booster battery.
4. Disconnect the opposite end of the positive (+) jumper cable from the positive (+) post of the vehicle with the discharged battery.

If frequent jump-starting is required to start your vehicle you should have the battery and charging system inspected at your authorized dealer.

CAUTION!

Accessories plugged into the vehicle power outlets draw power from the vehicle's battery, even when not in use (i.e., cellular phones, etc.). Eventually, if plugged in long enough without engine operation, the vehicle's battery will discharge sufficiently to degrade battery life and/or prevent the engine from starting.

WHAT TO DO IN EMERGENCIES

EMERGENCY TOW HOOKS

- If your vehicle is equipped with tow hooks, they are mounted in the front.
- For off-road recovery, it is recommended to use both of the front tow hooks to minimize the risk of damage to the vehicle.

CAUTION!

Tow hooks are for emergency use only, to rescue a vehicle stranded off-road. Do not use tow hooks for tow truck hookup or highway towing. You could damage your vehicle. Tow straps are recommended when towing the vehicle; chains may cause vehicle damage.

WARNING!

- Chains are not recommended for freeing a stuck vehicle. Chains may break, causing serious injury or death.
- Stand clear of vehicles when pulling with tow hooks. Tow straps and chains may break, causing serious injury.

SHIFT LEVER OVERRIDE

If a malfunction occurs and the shift lever cannot be moved out of the PARK position, you can use the following procedure to temporarily move the shift lever.

Have your vehicle inspected by your local authorized dealer immediately if the shift lever override has been used.

Column Shifter

1. Tilt the steering wheel to the full up position and firmly set the parking brake.
2. Turn the Key Fob to the ACC or ON/RUN position without starting the engine.
3. Press and maintain firm pressure on the brake pedal.
4. Insert a screwdriver or similar tool, into the access port (ringed circle) on the bottom of the steering column and push and hold the override release lever up.
5. Move the shift lever into the NEUTRAL position and start the vehicle.
6. Release the parking brake.



Shift Lock Manual Override Access Port

WHAT TO DO IN EMERGENCIES

Center Console Shifter

- Firmly set the parking brake.
- Turn the Key Fob to the ACC or ON/RUN position without starting the engine.
- Press and maintain firm pressure on the brake pedal.
- Using a screwdriver, press and hold the override tab through the access port on the center console.
- Move the shift lever into the NEUTRAL position and start the vehicle.
- Release the parking brake.



Shift Lock Manual Override Cover

MANUAL PARK RELEASE — EIGHT SPEED TRANSMISSION

- In order to push or tow the vehicle in cases where the transmission will not shift out of PARK (such as a dead battery), a Manual Park Release is available.
- Follow these steps to use the Manual Park Release:
 - Firmly apply the parking brake.
 - Using a small screwdriver or similar tool, remove the Manual Park Release access cover, which is just above the parking brake release handle, below and to the left of the steering column.



Manual Park Release Access Cover

WHAT TO DO IN EMERGENCIES

- Using the screwdriver or similar tool, push the Manual Park Release lever locking tab (just below the middle of the lever) to the right.



Manual Park Release Lever Locking Tab

- While holding the locking tab in the disengaged position, pull the tether strap to rotate the lever rearward, until it locks in place pointing towards the driver's seat. Release the locking tab and verify that the Manual Park Release lever is locked in the released position.
- The vehicle is now out of PARK and can be towed. Release the parking brake only when the vehicle is securely connected to a tow vehicle.

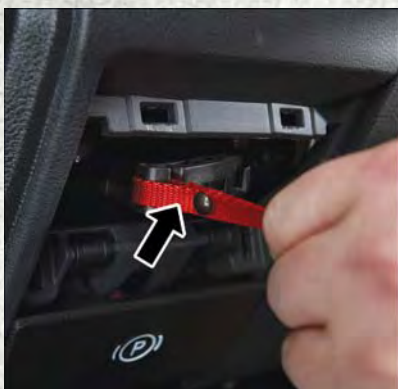

Manual Park Release Tether

WHAT TO DO IN EMERGENCIES

To Reset The Manual Park Release:

- Push the locking tab to the right, to unlock the lever.
- Rotate the Manual Park Release lever forward to its original position, until the locking tab snaps into place to secure the lever.
- Pull gently on the tether strap to confirm that the lever is locked in its stowed position.
- Re-install the access cover.

WARNING!

Always secure your vehicle by fully applying the parking brake, before activating the Manual Park Release. Activating the Manual Park Release will allow your vehicle to roll away if it is not secured by the parking brake or by proper connection to a tow vehicle. Activating the Manual Park Release on an unsecured vehicle could lead to serious injury or death for those in or around the vehicle.

TOWING A DISABLED VEHICLE

Towing Condition	Wheels OFF the Ground	2WD Models	4WD Models
Flat Tow	NONE	If transmission is operable: <ul style="list-style-type: none">• Transmission in NEUTRAL• 30 mph (48 km/h) max• 15 miles (24 km) max distance	<ul style="list-style-type: none">• Auto Transmission in PARK• Manual Transmission in gear (NOT NEUTRAL)• Transfer Case in NEUTRAL• Tow in FORWARD direction
Wheel Lift or Dolly Tow	Front	OK	NOT ALLOWED
	Rear		NOT ALLOWED
Flatbed	ALL	BEST METHOD	BEST METHOD

WHAT TO DO IN EMERGENCIES

FREING A STUCK VEHICLE

- If your vehicle becomes stuck in mud, sand or snow, it can often be moved using a rocking motion. Turn your steering wheel right and left to clear the area around the front wheels. Then shift back and forth between DRIVE and REVERSE (with automatic transmission) or 2nd gear and REVERSE (with manual transmission) while gently pressing the accelerator. Use the least amount of accelerator pedal pressure that will maintain the rocking motion, without spinning the wheels or racing the engine.

NOTE:

Press the "ESC Off" switch, to place the Electronic Stability Control (ESC) system in "Partial Off" mode before rocking the vehicle. Once the vehicle has been freed, press the "ESC Off" switch again to restore "ESC On" mode.

CAUTION!

- Racing the engine or spinning the wheels may lead to transmission overheating and failure. Allow the engine to idle with the shift lever in NEUTRAL for at least one minute after every five rocking-motion cycles. This will minimize overheating and reduce the risk of clutch or transmission failure during prolonged efforts to free a stuck vehicle.
- When "rocking" a stuck vehicle by moving between DRIVE/2nd and REVERSE, do not spin the wheels faster than 15 mph (24 km/h), or drivetrain damage may result.
- Revving the engine or spinning the wheels too fast may lead to transmission overheating and failure. It can also damage the tires. Do not spin the wheels above 30 mph (48 km/h) while in gear (no transmission shifting occurring).

WHAT TO DO IN EMERGENCIES

EVENT DATA RECORDER (EDR)

This vehicle is equipped with an Event Data Recorder (EDR). The main purpose of an EDR is to record, in certain crash or near crash-like situations, such as an air bag deployment or hitting a road obstacle, data that will assist in understanding how a vehicle's systems performed. The EDR is designed to record data related to vehicle dynamics and safety systems for a short period of time, typically 30 seconds or less. The EDR in this vehicle is designed to record such data as:

- How various systems in your vehicle were operating.
- Whether or not the driver and passenger safety belts were buckled/fastened.
- How far (if at all) the driver was depressing the accelerator and/or brake pedal.
- How fast the vehicle was traveling.

These data can help provide a better understanding of the circumstances in which crashes and injuries occur.

NOTE:

EDR data is recorded by your vehicle only if a non-trivial crash situation occurs; no data is recorded by the EDR under normal driving conditions and no personal data (e.g. name, gender, age, and crash location) is recorded. However, other parties, such as law enforcement, could combine the EDR data with the type of personally identifying data routinely acquired during a crash investigation.

To read data recorded by an EDR, special equipment is required, and access to the vehicle or the EDR is needed. In addition to the vehicle manufacturer, other parties such as law enforcement, that have the special equipment, can read the information if they have access to the vehicle or the EDR.

MAINTAINING YOUR VEHICLE

OPENING THE HOOD

1. Pull the hood release lever located below the steering wheel at the base of the instrument panel.
2. Reach into the opening beneath the center of the hood and move the safety latch lever while lifting the hood at the same time.



Hood Release Lever Location

WARNING!

Be sure the hood is fully latched before driving your vehicle. If the hood is not fully latched, it could open when the vehicle is in motion and block your vision. Failure to follow this warning could result in serious injury or death.

MAINTAINING YOUR VEHICLE

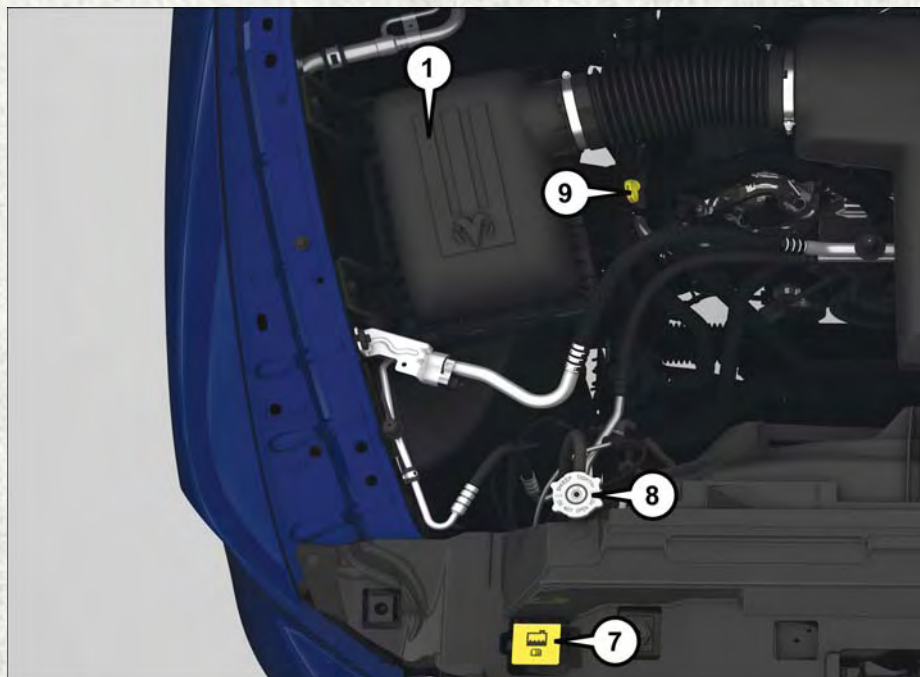

ENGINE COMPARTMENT

3.6L Engine

1. Air Cleaner Filter
2. Engine Oil Fill (Under Cover)
3. Brake Fluid Reservoir
4. Battery
5. Power Distribution Center (Fuses)
6. Alternator
7. Coolant Reservoir
8. Water Pump
9. Serpentine Belt

MAINTAINING YOUR VEHICLE

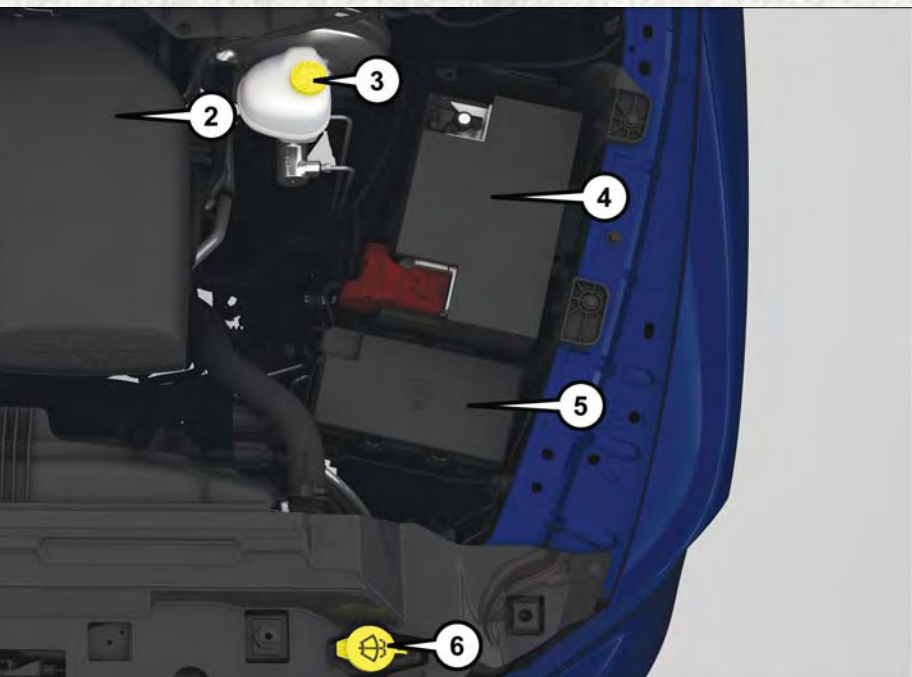

- 6. Washer Fluid Reservoir
- 7. Engine Coolant Reservoir
- 8. Engine Coolant Pressure Cap
- 9. Engine Oil Dipstick

MAINTAINING YOUR VEHICLE

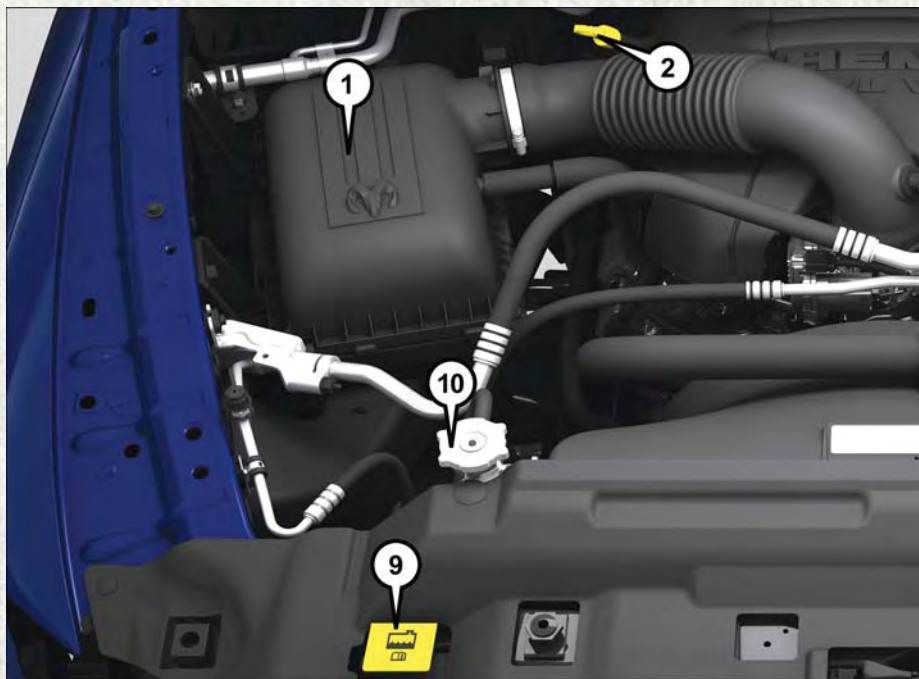

5.7L Engine

1. Air Cleaner Filter
2. Transmission Fluid Dipstick
3. Engine Oil Fill
4. Brake Fluid Reservoir
5. Battery

MAINTAINING YOUR VEHICLE

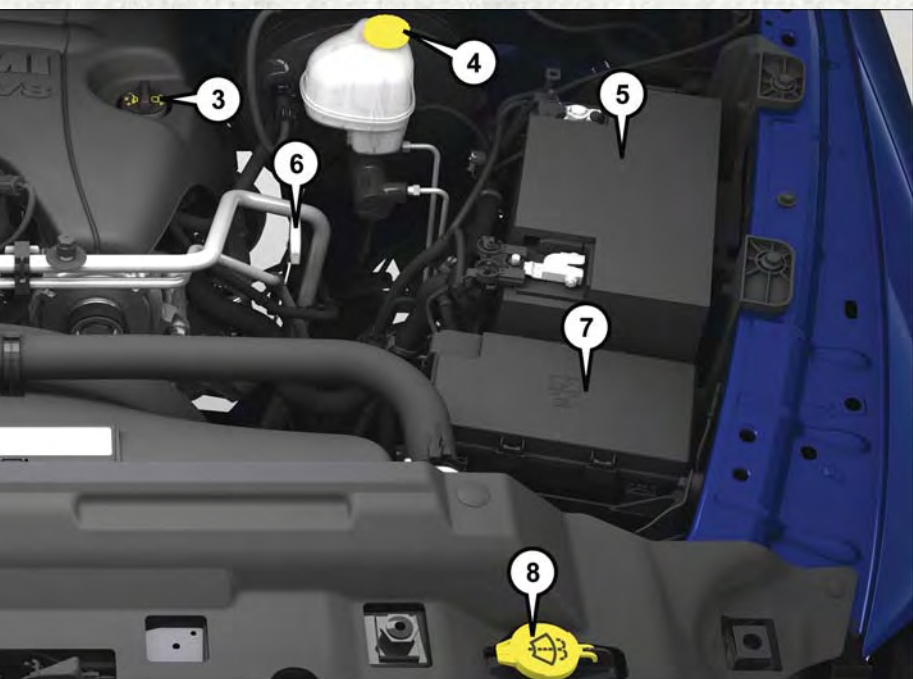

6. Engine Oil Dipstick
7. Power Distribution Center (Fuses)
8. Washer Fluid Reservoir
9. Engine Coolant Reservoir
10. Engine Coolant Pressure Cap

MAINTAINING YOUR VEHICLE



6.4L Engine

1. Engine Coolant Reservoir
2. Transmission Fluid Dipstick
3. Engine Oil Fill
4. Brake Fluid Reservoir
5. Aux Power Distribution Center (Fuses)
6. Battery

MAINTAINING YOUR VEHICLE

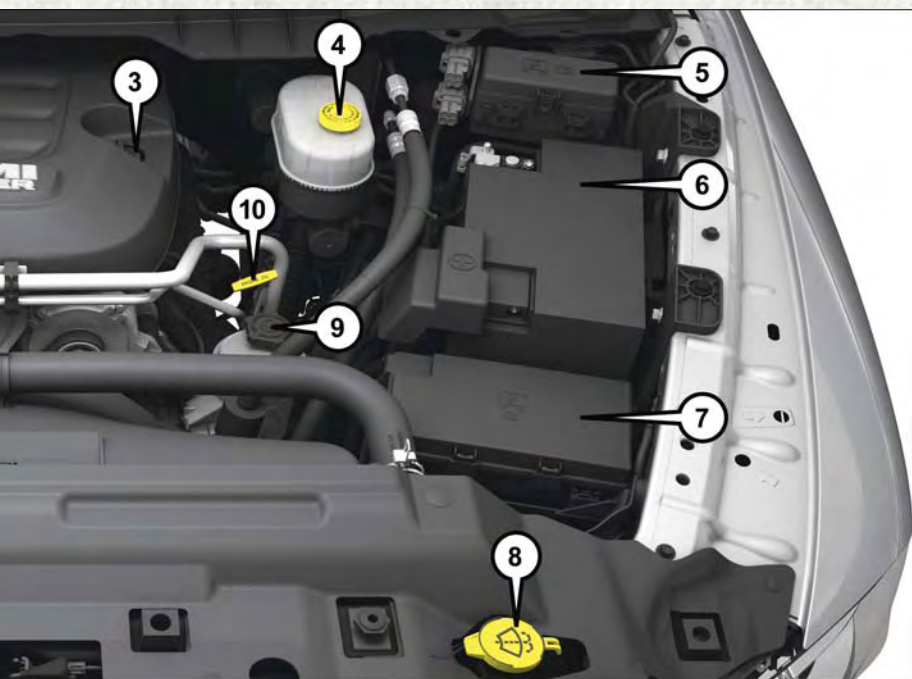

- 7. Power Distribution Center (Fuses)
- 8. Washer Fluid Reservoir
- 9. Power Steering Reservoir
- 10. Engine Oil Dipstick
- 11. Air Cleaner Filter

MAINTAINING YOUR VEHICLE

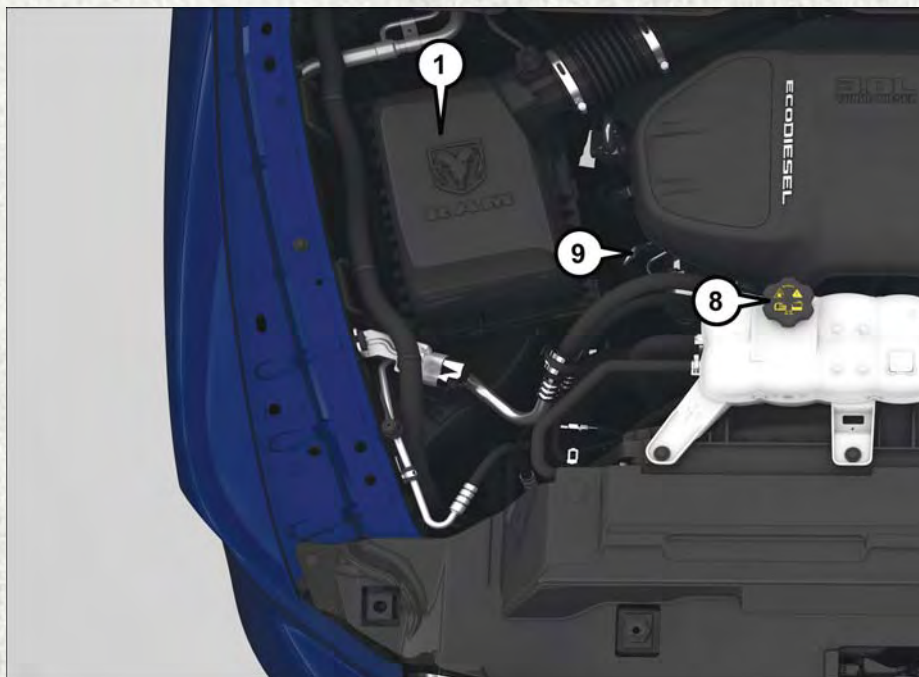

3.0L Diesel Engine

1. Air Cleaner Filter
2. Engine Oil Fill
3. Brake Fluid Reservoir
4. Aux Power Distribution Center (Fuses)
5. Battery

MAINTAINING YOUR VEHICLE

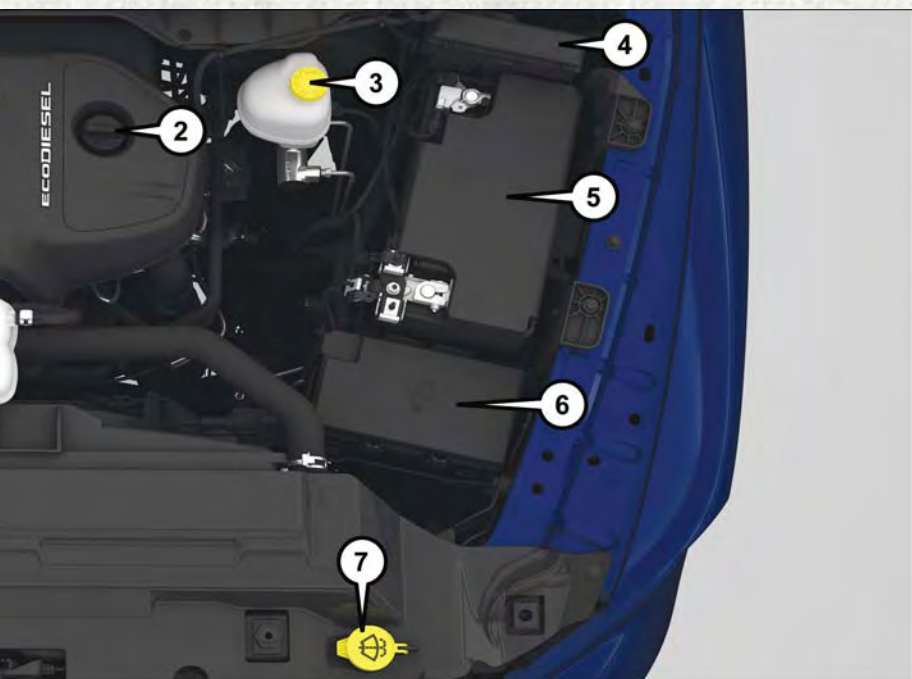

- 6. Power Distribution Center (Fuses)
- 7. Washer Fluid Reservoir
- 8. Engine Coolant Reservoir
- 9. Engine Oil Dipstick

MAINTAINING YOUR VEHICLE



6.7L Diesel Engine With 68RFE Transmission — If Equipped

1. Batteries
2. Engine Coolant Reservoir
3. Transmission Fluid Dipstick
4. Brake Fluid Reservoir
5. Aux Power Distribution Center (Fuses)
6. Washer Fluid Reservoir

MAINTAINING YOUR VEHICLE

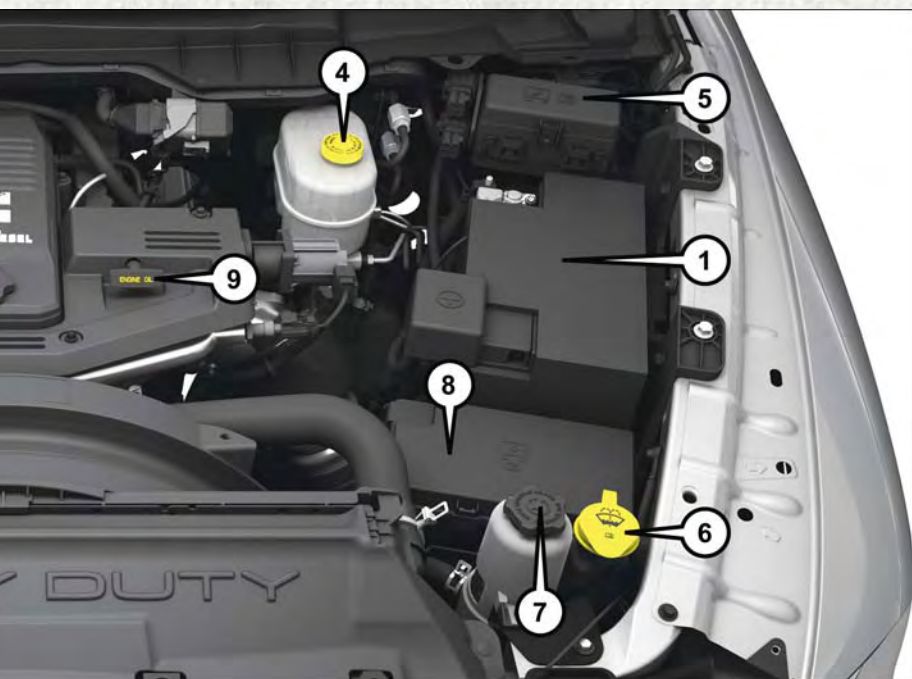

7. Power Steering Fluid Reservoir
8. Power Distribution Center (Fuses)
9. Engine Oil Dipstick
10. Engine Oil Fill
11. Air Cleaner Filter

MAINTAINING YOUR VEHICLE



6.7L Diesel Engine With AS69RC Transmission — If Equipped

1. Batteries
2. Engine Coolant Reservoir
3. Transmission Fluid Dipstick
4. Brake Fluid Reservoir
5. Auz Power Distribution Center (Fuses)
6. Power Distribution Center (Fuses)

MAINTAINING YOUR VEHICLE

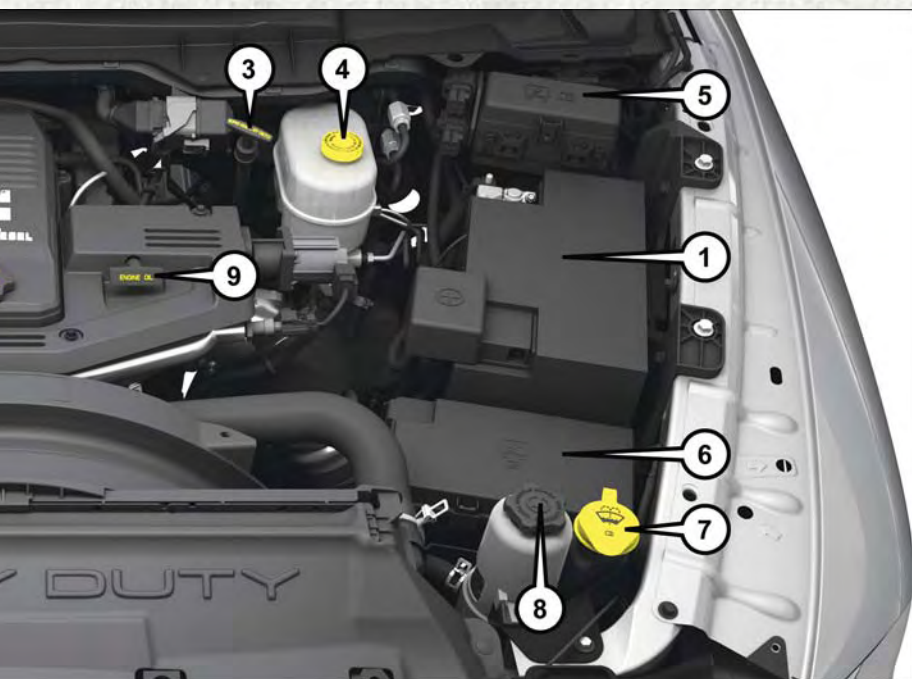

7. Washer Fluid Reservoir
8. Power Steering Fluid Reservoir
9. Engine Oil Dipstick
10. Engine Oil Fill
11. Air Cleaner Filter

MAINTAINING YOUR VEHICLE

GAS FLUID CAPACITIES

	U.S.	Metric
Fuel (Approximate)		
1500 Regular Cab Shortbed/Crew Quad Cab Models	26 Gallons	98 Liters
1500 Regular Cab Longbed/Crew Quad Cab Models (Optional)	32 Gallons	121 Liters
2500/3500 Shortbed Models	31 Gallons	117 Liters
2500/3500 Longbed Models	32 Gallons	121 Liters
Engine Oil With Filter		
3.6L Engine (We recommend you use SAE 5W-20, API Certified)	6 Quarts	5.6 Liters
5.7L Engines (We recommend you use SAE 5W-20, API Certified)	7 Quarts	6.6 Liters
5.7L Engine (We recommend you use SAE 5W-30, API Certified), for 2500/3500 trucks operating under a gross combined weight rating greater than 14,000 lbs (6 350 kg).	7 Quarts	6.6 Liters
6.4L Engines (We recommend you use SAE 0W-40 engine oil meeting the requirements of Chrysler Material Standard MS-12633 for use in all operating temperatures.)	7 Quarts	6.6 Liters
Cooling System		
3.6L Engine (We recommend you use MOPAR® Antifreeze/Coolant 10 Year/150,000 Mile Formula that meets the requirements of Chrysler Material Standard MS-12106.)	13.7 Quarts	13 Liters
5.7L Engine – 1500 Models (We recommend you use MOPAR® Antifreeze/Coolant 10 Year/150,000 Mile Formula that meets the requirements of Chrysler Material Standard MS-12106.)	18.3 Quarts	17.3 Liters
5.7L Engine – 2500/3500 Models (We recommend you use MOPAR® Antifreeze/Coolant 10 Year/150,000 Mile Formula that meets the requirements of Chrysler Material Standard MS-12106.)	18.3 Quarts	17.3 Liters
6.4 Liter Engine – MOPAR® Antifreeze/Engine Coolant 10 Year/150,000 Mile Formula that meets the requirements of Chrysler Material Standard MS-12106.	16.6 Quarts	15.7 Liters

MAINTAINING YOUR VEHICLE

GAS FLUIDS, LUBRICANTS AND GENUINE PARTS

Engine

Component	Fluid, Lubricant, or Genuine Part
Engine Coolant	We recommend you use MOPAR® Antifreeze/Coolant 10 Year/150,000 Mile Formula OAT (Organic Additive Technology).
Engine Oil – 3.6L Engine	We recommend you use API Certified SAE 5W-20 Engine Oil, meeting the requirements of Chrysler Material Standard MS-6395 such as MOPAR®, Pennzoil®, and Shell Helix®. Refer to your engine oil filler cap for correct SAE grade. MOPAR® SAE 5W-30 engine oil approved to Chrysler Material Standard MS-6395 may be used when SAE 5W-20 engine oil meeting MS-6395 is not available.
Engine Oil – 5.7L Engine	We recommend you use API Certified SAE 5W-20 Engine Oil, meeting the requirements of Chrysler Material Standard MS-6395 such as MOPAR®, Pennzoil®, and Shell Helix®. Refer to your engine oil filler cap for correct SAE grade.
Engine Oil – 5.7L Engine 2500/3500 trucks operating under a gross combined weight rating greater than 14,000 lbs/(6,350 kg.)	We recommend you use API Certified SAE 5W-30 Engine Oil, meeting the requirements of Chrysler Material Standard MS-6395 such as MOPAR®, Pennzoil®, Shell Helix® or equivalent. Refer to your engine oil filler cap for correct SAE grade.
Engine Oil – 6.4L	For best performance and maximum protection under all types of operating conditions, the manufacturer only recommends full synthetic engine oils that meet the American Petroleum Institute (API) categories of SN. The manufacturer recommends the use of Pennzoil Ultra™ 0W-40 or equivalent MOPAR® engine oil meeting the requirements of Chrysler Material Standard MS-12633 for use in all operating temperatures.
Engine Oil Filter	We recommend you use MOPAR® brand Engine Oil Filters.
Spark Plugs	We recommend you use MOPAR® Spark Plugs.
Fuel Selection – 3.6L Engine	87 Octane.
Fuel Selection – 5.7L/6.4L Engines	87 Octane Acceptable - 89 Octane Recommended.

MAINTAINING YOUR VEHICLE

CAUTION!

- Mixing of engine coolant (antifreeze) other than specified Organic Additive Technology (OAT) engine coolant (antifreeze), may result in engine damage and may decrease corrosion protection. Organic Additive Technology (OAT) engine coolant is different and should not be mixed with Hybrid Organic Additive Technology (HOAT) engine coolant (antifreeze) or any “globally compatible” coolant (antifreeze). If a non-OAT engine coolant (antifreeze) is introduced into the cooling system in an emergency, the cooling system will need to be drained, flushed, and refilled with fresh OAT coolant (conforming to MS-12106), by an authorized dealer as soon as possible.
- Do not use water alone or alcohol-based engine coolant (antifreeze) products. Do not use additional rust inhibitors or antirust products, as they may not be compatible with the radiator engine coolant and may plug the radiator.
- This vehicle has not been designed for use with propylene glycol-based engine coolant (antifreeze). Use of propylene glycol-based engine coolant (antifreeze) is not recommended.

E-85 Flexible Fuel — 3.6L Engine Only

CAUTION!

Only vehicles with the E-85 fuel filler door label or a yellow gas cap can operate on E-85.

Refer to your Owner's Manual on the DVD for further details.

Chassis

Component	Fluid, Lubricant, or Genuine Part
Automatic Transmission – Eight-Speed Automatic	Use only MOPAR® ZF 8&9 Speed ATF™ Automatic Transmission Fluid, or equivalent. Failure to use the correct fluid may affect the function or performance of your transmission.
Automatic Transmission – Six-Speed Automatic with Gasoline Engine (For Diesel Engine see Diesel Supplement)	Use only ATF+4® Automatic Transmission Fluid. Failure to use ATF+4® fluid may affect the function or performance of your transmission. We recommend MOPAR® ATF+4® fluid.
Transfer Case	We recommend you use MOPAR® BW44–44 Transfer Case Fluid.
Front Axle – 1500 Four-Wheel Drive Models	We recommend you use MOPAR® GL-5 Synthetic Axle Lubricant SAE 75W-85.

MAINTAINING YOUR VEHICLE

Component	Fluid, Lubricant, or Genuine Part
Rear Axle – 1500 Models	We recommend you use MOPAR® Synthetic Gear Lubricant SAE 75W-140 (MS-8985). Limited-Slip Rear Axles require the addition of 5 oz. (148 ml) MOPAR® Limited Slip Additive (MS-10111).
Front and Rear Axle – 2500/3500 Models	We recommend you use Synthetic, GL-5 SAE, 75W-90. Limited slip additive is not required for Limited-Slip Rear Axles.
Brake Master Cylinder	We recommend you use MOPAR® DOT 3. If DOT 3 brake fluid is not available, then DOT 4 is acceptable.
Power Steering Reservoir – 2500/3500 Models	We recommend you use MOPAR® Power Steering Fluid +4 or MOPAR® ATF+4® Automatic Transmission Fluid.

1500 3.0 DIESEL FLUID CAPACITIES

	U.S.	Metric
Fuel (Approximate)		
3.0L Diesel Engine	26 Gallons	98.5 Liters
Diesel Exhaust Fluid Tank	8 Gallons	30.3 Liters
Engine Oil With Filter		
3.0 Liter Diesel Engine (SAE 5W-30 Synthetic, API Certified Low Ash)	10.5 Quarts	10 Liters
Cooling System		
3.0L Turbo Diesel Engine (MOPAR® Engine Coolant/Antifreeze 10 Year/ 150,000 Mile Formula OAT (Organic Additive Technology))	11.6 Quarts	11 Liters

1500 3.0 DIESEL FLUIDS, LUBRICANTS AND GENUINE PARTS

Engine

Component	Fluid, Lubricant, or Genuine Part
Engine Coolant	We recommend you use MOPAR® Antifreeze/Coolant 10 Year/ 150,000 Mile Formula OAT (Organic Additive Technology).
Engine Oil	Only use ACEA C3 5W-30 Synthetic Low Ash engine oil meeting Chrysler material standard MS-11106 or Pennzoil Ultra Euro L full synthetic 5W-30 motor oil.
Engine Oil Filter	We recommend you use MOPAR® Engine Oil Filters.

MAINTAINING YOUR VEHICLE

Component	Fluid, Lubricant, or Genuine Part
Fuel Filters	We recommend you use MOPAR® Fuel Filter. Must meet 3 micron rating. Using a fuel filter that does not meet the manufacturers filtration and water separating requirements can severely impact fuel system life and reliability.
Fuel Selection	Use good quality diesel fuel from a reputable supplier in your vehicle. Federal law requires that you must fuel this vehicle with Ultra Low Sulfur Highway Diesel fuel (15 ppm Sulfur maximum) and prohibits the use of Low Sulfur Highway Diesel fuel (500 ppm Sulfur maximum) to avoid damage to the emissions control system. For most year-round service, No. 2 diesel fuel meeting ASTM specification D-975 Grade S15 will provide good performance. We recommend you use a blend of up to 5% biodiesel, meeting ASTM specification D-975 with your diesel engine. This vehicle is compatible with biodiesel blends greater than 5% but no greater than 20% biodiesel meeting ASTM specification D-7467 provided the shortened maintenance intervals are followed as directed.
Diesel Exhaust Fluid	MOPAR® Diesel Exhaust Fluid (API Certified) (DEF) or equivalent that has been API Certified to the ISO 22241 standard. Use of fluids not API Certified to ISO 22241 may result in system damage.

NOTE:

If the vehicle is exposed to extreme cold (below 20°F or -7°C), or is required to operate at colder-than-normal conditions for prolonged periods, use climatized No. 2 diesel fuel or dilute the No. 2 diesel fuel with 50% No. 1 diesel fuel. This will provide better protection from fuel gelling or wax-plugging of the fuel filter.

CAUTION!

- Mixing of engine coolant (antifreeze) other than specified Organic Additive Technology (OAT) engine coolant (antifreeze), may result in engine damage and may decrease corrosion protection. Organic Additive Technology (OAT) engine coolant is different and should not be mixed with Hybrid Organic Additive Technology (HOAT) engine coolant (antifreeze) or any “globally compatible” coolant (antifreeze). If a non-OAT engine coolant (antifreeze) is introduced into the cooling system in an emergency, the cooling system will need to be drained, flushed, and refilled with fresh OAT coolant (conforming to MS-12106), by an authorized dealer as soon as possible.
- Do not use water alone or alcohol-based engine coolant (antifreeze) products. Do not use additional rust inhibitors or antirust products, as they may not be compatible with the radiator engine coolant and may plug the radiator.
- This vehicle has not been designed for use with propylene glycol-based engine coolant (antifreeze). Use of propylene glycol-based engine coolant (antifreeze) is not recommended.

MAINTAINING YOUR VEHICLE

Chassis

Component	Fluid, Lubricant, or Genuine Part
Automatic Transmission	Only use Mopar® ZF 8&9 Speed ATF™ Automatic Transmission Fluid or equivalent. Failure to use the correct fluid may affect the function or performance of your transmission.
Transfer Case	We recommend you use MOPAR® BW44-44 Transfer Case Fluid.
Front Axle – 1500 Four-Wheel Drive Models	We recommend you use MOPAR® GL-5 Synthetic Axle Lubricant SAE 75W-85.
Rear Axle	We recommend you use MOPAR® Synthetic Gear Lubricant SAE 75W-140 (MS-8985). Limited-Slip Rear Axles require the addition of 5 oz. (148 ml) MOPAR® Limited Slip Additive (MS-10111).
Brake Master Cylinder	We recommend you use MOPAR® DOT 3 Brake Fluid, SAE J1703 should be used. If DOT 3, SAE J1703 brake fluid is not available, then DOT 4 is acceptable.

6.7L CUMMINS® DIESEL FLUID CAPACITIES

	U.S.	Metric
Fuel (Approximate)		
2500/3500 Standard Cab Longbed Models	28 Gallons	106 Liters
2500/3500 Crew/Mega Cab Shortbed Models	31 Gallons	129 Liters
2500/3500 Crew Cab Longbed Models	32 Gallons	132 Liters
Standard Rear Tank – Chassis Cab Only	52 Gallons	197 Liters
Optional Midship Tank – Chassis Cab Only	22 Gallons	83 Liters
Diesel Exhaust Fluid Tank (Approximate) – 2500/3500 Models	5.5 Gallons	21 Liters
Diesel Exhaust Fluid Tank (Approximate) – Chassis Cab	9 Gallons	34 Liters
Engine Oil With Filter		
6.7L Turbo Diesel Engine	12 Quarts	11.4 Liters
Cooling System		
6.7L Turbo Diesel Engine (MOPAR® Engine Coolant/Antifreeze 10 Year/150,000 Mile Formula)	5.7 Gallons	21.4 Liters

MAINTAINING YOUR VEHICLE

6.7L CUMMINS® DIESEL FLUIDS, LUBRICANTS AND GENUINE PARTS

Engine

Component	Fluid, Lubricant, or Genuine Part
Engine Coolant	We recommend you use MOPAR® Antifreeze/Coolant 10 Year/150,000 Mile Formula OAT (Organic Additive Technology).
Engine Oil	<p>In ambient temperatures above 0°F (-18°C), we recommend you use 15W-40 engine oil such as MOPAR®, Shell Rotella® and Shell Rimula® that meets Chrysler Materials Standard MS-10902 and the API CJ-4 engine oil category is required. Products meeting Cummins® CES 20081 may also be used. The identification of these engine oils is typically located on the back of the oil container.</p> <p>In ambient temperatures below 0°F (-18°C), we recommend you use 5W-40 synthetic engine oil such as MOPAR®, Shell Rotella® and Shell Rimula® that meets Chrysler Materials Standard MS-10902 and the API CJ-4 engine oil category is required.</p>
Engine Oil Filter	We recommend you use MOPAR® Engine Oil Filters.
Fuel Filters	We recommend you use MOPAR® Fuel Filter. Must meet 3 micron rating. Using a fuel filter that does not meet the manufacturers filtration and water separating requirements can severely impact fuel system life and reliability.
Crankcase Ventilation Filter	We recommend you use MOPAR® CCV Filter.
Fuel Selection	<p>Use good quality diesel fuel from a reputable supplier in your vehicle. Federal law requires that you must fuel this vehicle with Ultra Low Sulfur Highway Diesel fuel (15 ppm Sulfur maximum) and prohibits the use of Low Sulfur Highway Diesel fuel (500 ppm Sulfur maximum) to avoid damage to the emissions control system.</p> <p>For most year-round service, No. 2 diesel fuel meeting ASTM specification D-975 Grade S15 will provide good performance.</p> <p>If the vehicle is exposed to extreme cold (below 20°F or -7°C), or is required to operate at colder-than-normal conditions for prolonged periods, use climatized No. 2 diesel fuel or dilute the No. 2 diesel fuel with 50% No. 1 diesel fuel. This will provide better protection from fuel gelling or wax-plugging of the fuel filters.</p> <p>This vehicle is fully compatible with biodiesel blends up to 5% biodiesel meeting ASTM specification D-975. Pickup models, and Chassis Cab models configured with optional B20 capability, are additionally compatible with 20% biodiesel meeting ASTM specification D-7467.</p>
Diesel Exhaust Fluid	MOPAR® Diesel Exhaust Fluid (API Certified) (DEF) or equivalent that has been API Certified to the ISO 22241 standard. Use of fluids not API Certified to ISO 22241 may result in system damage. You can receive assistance in locating DEF in the United States by calling 866-RAM-INFO (866-726-4636). In Canada call 1-800-465-2001 (English) or 1-800-387-9983 (French).

MAINTAINING YOUR VEHICLE

CAUTION!

- Mixing of engine coolant (antifreeze) other than specified Organic Additive Technology (OAT) engine coolant (antifreeze), may result in engine damage and may decrease corrosion protection. Organic Additive Technology (OAT) engine coolant is different and should not be mixed with Hybrid Organic Additive Technology (HOAT) engine coolant (antifreeze) or any “globally compatible” coolant (antifreeze). If a non-OAT engine coolant (antifreeze) is introduced into the cooling system in an emergency, the cooling system will need to be drained, flushed, and refilled with fresh OAT coolant (conforming to MS-12106), by an authorized dealer as soon as possible.
- Do not use water alone or alcohol-based engine coolant (antifreeze) products. Do not use additional rust inhibitors or antirust products, as they may not be compatible with the radiator engine coolant and may plug the radiator.
- This vehicle has not been designed for use with propylene glycol-based engine coolant (antifreeze). Use of propylene glycol-based engine coolant (antifreeze) is not recommended.

Chassis

Component	Fluid, Lubricant, or Genuine Part
Automatic Transmission – If Equipped (Six-Speed 68RFE) – Pickup models without PTO	Only use ATF+4® Automatic Transmission Fluid. Failure to use ATF+4® fluid may affect the function or performance of your transmission. We recommend MOPAR® ATF+4® fluid.
Automatic Transmission – If Equipped (Six-Speed AS69RC) – Pickup models with PTO, and all Chassis Cab models	Only use MOPAR® ASRC Automatic Transmission Fluid or equivalent. Failure to use the proper fluid may affect the function or performance of your transmission.
Transfer Case	We recommend you use MOPAR® BW44–44 Transfer Case Fluid.
Front and Rear Axle Fluid (2500/3500)	We recommend you use Synthetic, GL-5 SAE 75W-85. Limited slip additive is not required for Limited-Slip Rear Axles.
Front and Rear Axle Fluid (4500/5500)	We recommend you use Synthetic, GL-5 SAE 75W-90. Limited slip additive is not required for Limited-Slip Rear Axles.
Clutch Linkage	We recommend you use MOPAR® Multi-Purpose Grease, NLGI Grade 2 E.P. or equivalent.
Manual Transmission (G-56) – If Equipped	We recommend you use MOPAR® ATF+4® Automatic Transmission Fluid or equivalent licensed ATF+4® product.

MAINTAINING YOUR VEHICLE

MAINTENANCE PROCEDURES

For information on the maintenance procedures for your vehicle, please refer to “Maintenance Procedures” in “Maintaining Your Vehicle” in your Owner’s Manual or applicable supplement on the DVD for further details.

MAINTENANCE SCHEDULE — GASOLINE ENGINE

Your vehicle is equipped with an automatic oil change indicator system. The oil change indicator system will remind you that it is time to take your vehicle in for scheduled maintenance.

Based on engine operation conditions, the oil change indicator message will illuminate. This means that service is required for your vehicle. Operating conditions such as frequent short-trips, trailer tow, extremely hot or cold ambient temperatures, and E85 fuel usage will influence when the “Oil Change Required” message is displayed. Severe Operating Conditions can cause the change oil message to illuminate as early as 3,500 miles (5,600 km) since last reset. Have your vehicle serviced as soon as possible, within the next 500 miles (805 km).

Your authorized dealer will reset the oil change indicator message after completing the scheduled oil change. If a scheduled oil change is performed by someone other than your authorized dealer, the message can be reset by referring to the steps described under “Instrument Cluster Warning Lights” in “What To Do In Emergencies” in this guide or “Electronic Vehicle Information Center (EVIC)” or “Driver Information Display (DID)” in “Understanding Your Instrument Panel” in your Owner’s Manual on the DVD for further information.

NOTE:

1500 Models Only

- Under no circumstances should oil change intervals exceed 10,000 miles (16,000 km) or twelve months on 1500 trucks, whichever comes first.

2500 – 3500 Models

- Under no circumstances should oil change intervals exceed 8,000 miles (13,000 km) or twelve months on 2500 – 3500 trucks, whichever comes first.

MAINTAINING YOUR VEHICLE

Severe Duty All Models

- Change Engine Oil at 4000 miles (6,500 km) if the vehicle is operated in a dusty and off road environment. This type of vehicle use is considered Severe Duty.

Once A Month Or Before A Long Trip:

- Check engine oil level
- Check windshield washer fluid level
- Check tire pressure and look for unusual wear or damage. Rotate tires at the first sign of irregular wear, even if it occurs before the oil indicator system turns on.
- Check the fluid levels of the coolant reservoir, brake master cylinder, power steering (2500/3500 Models Only) and automatic transmission (six-speed only) and fill as needed
- Check function of all interior and exterior lights

Required Maintenance

Refer to the Maintenance Schedules on the following pages for required maintenance.

At Every Oil Change Interval As Indicated By Oil Change Indicator System:
• Change oil and filter.
• Rotate the tires. Rotate at the first sign of irregular wear, even if it occurs before the oil indicator system turns on.
• Inspect battery and clean and tighten terminals as required.
• Inspect automatic transmission fluid if equipped with dipstick.
• Inspect brake pads, shoes, rotors, drums, hoses and park brake.
• Inspect engine cooling system protection and hoses.
• Inspect exhaust system.
• Inspect engine air cleaner if using in dusty or off-road conditions.
• Lube the front drive shaft fitting (2500/3500 (4x4) models only).

MAINTAINING YOUR VEHICLE

Maintenance Chart — Gasoline Engine

Mileage or time passed (whichever comes first)	20,000	30,000	40,000	50,000	60,000	70,000	80,000	90,000	100,000	110,000	120,000	130,000	140,000	150,000
Or Years:	2	3	4	5	6	7	8	9	10	11	12	13	14	15
Or Kilometers:	32,000	48,000	64,000	80,000	96,000	112,000	128,000	144,000	160,000	176,000	192,000	208,000	224,000	240,000
Additional Inspections														
Inspect the CV/Universal joints.		X			X			X			X			X
Inspect front suspension, tie rod ends, and replace if necessary.	X		X		X		X		X		X		X	
Inspect the front and rear axle surfaces. If gear oil leakage is suspected, check the fluid level. If using your vehicle for police, taxi, fleet, off-road or frequent trailer towing, change axle fluid.	X		X		X		X		X		X		X	
Inspect the brake linings, replace as necessary.	X		X		X		X		X		X		X	
Adjust parking brake as necessary.	X		X		X		X		X		X		X	
Inspect transfer case fluid.		X						X						X
Additional Maintenance														
Replace engine air filter.		X			X			X			X			X
Replace spark plugs (3.6L engine). **									X					
Replace spark plugs (5.7L engine). **									X					
Replace spark plugs (6.4L engine). **									X					
Flush and replace the engine coolant at 10 years or 150,000 miles (240,000 km) whichever comes first.									X					X

MAINTAINING YOUR VEHICLE

Mileage or time passed (whichever comes first)	20,000	30,000	40,000	50,000	60,000	70,000	80,000	90,000	100,000	110,000	120,000	130,000	140,000	150,000
0r Years:	2	3	4	5	6	7	8	9	10	11	12	13	14	15
Or Kilometers:	32,000	48,000	64,000	80,000	96,000	112,000	128,000	144,000	160,000	176,000	192,000	208,000	224,000	240,000
Change automatic transmission fluid and filter(s) (six-speed automatic only), if using your vehicle for police, taxi, fleet, or frequent trailer towing.					X									
Change automatic transmission fluid and filter(s) (six-speed automatic only).											X			
Inspect the transfer case fluid, change for any of the following: police, taxi, fleet, or frequent trailer towing.					X						X			
Change the transfer case fluid.											X			
Inspect and replace PCV valve if necessary.									X					

** The spark plug change interval is mileage based only, yearly intervals do not apply.

WARNING!

- You can be badly injured working on or around a motor vehicle. Do only service work for which you have the knowledge and the right equipment. If you have any doubt about your ability to perform a service job, take your vehicle to a competent mechanic.
- Failure to properly inspect and maintain your vehicle could result in a component malfunction and effect vehicle handling and performance. This could cause an accident.

MAINTAINING YOUR VEHICLE

MAINTENANCE RECORD

	Odometer	Date	Signature, Authorized Service Center
20,000 Miles (32,000 km) or 2 Years			
30,000 Miles (48,000 km) or 3 Years			
40,000 Miles (64,000 km) or 4 Years			
50,000 Miles (80,000 km) or 5 Years			
60,000 Miles (96,000 km) or 6 Years			
70,000 Miles (112,000 km) or 7 Years			
80,000 Miles (128,000 km) or 8 Years			

	Odometer	Date	Signature, Authorized Service Center
90,000 Miles (144,000 km) or 9 Years			
100,000 Miles (160,000 km) or 10 Years			
110,000 Miles (176,000 km) or 11 Years			
120,000 Miles (192,000 km) or 12 Years			
130,000 Miles (208,000 km) or 13 Years			
140,000 Miles (224,000 km) or 14 Years			
150,000 Miles (240,000 km) or 15 Years			

MAINTAINING YOUR VEHICLE

MAINTENANCE SCHEDULE — 1500 3.0L DIESEL ENGINE

Your vehicle is equipped with an automatic oil change indicator system. The oil change indicator system will remind you that it is time to take your vehicle in for scheduled maintenance.

Based on engine operation conditions, the oil change indicator message will illuminate. This means that service is required for your vehicle. Operating conditions such as frequent short-trips, trailer tow, extremely hot or cold ambient temperatures will influence when the “Oil Change Required” message is displayed. Severe Operating Conditions can cause the change oil message to illuminate as early as 3,500 miles (5,600 km) since last reset. Have your vehicle serviced as soon as possible, within the next 500 miles (805 km).

Your authorized dealer will reset the oil change indicator message after completing the scheduled oil change. If a scheduled oil change is performed by someone other than your authorized dealer, the message can be reset by referring to the steps described under “Instrument Cluster Warning Lights” in “What To Do In Emergencies” in this guide or “Electronic Vehicle Information Center (EVIC)” or “Driver Information Display (DID)” in “Understanding Your Instrument Panel” in your Owner’s Manual on the DVD for further information.

NOTE:

Under no circumstances should oil change intervals exceed 10,000 miles (16,000 km) or twelve months, whichever comes first.

Once A Month Or Before A Long Trip:

- Check engine oil level
- Check windshield washer fluid level
- Check the tire inflation pressures and look for unusual wear or damage
- Check the fluid levels of the coolant reservoir, brake master cylinder and power steering, and fill as needed
- Check function of all interior and exterior lights

Required Maintenance

Refer to the Maintenance Schedules on the following pages for required maintenance.

At Every Oil Change Interval As Indicated By Oil Change Indicator System:
• Change oil and filter.
• Completely fill the Diesel Exhaust Fluid tank.
• Rotate the tires. Rotate at the first sign of irregular wear, even if it occurs before the oil indicator system turns on.
• Inspect battery and clean and tighten terminals as required.
• Inspect brake pads, shoes, rotors, drums, hoses and park brake.
• Inspect engine cooling system protection and hoses.
• Inspect exhaust system.
• Inspect engine air cleaner if using in dusty or off-road conditions.

MAINTAINING YOUR VEHICLE

Maintenance Chart — Diesel Fuel Up To B5 Biodiesel (1500 Diesel)

Mileage or time passed (whichever comes first)	16,000	20,000	30,000	40,000	50,000	60,000	70,000	80,000	90,000	100,000	110,000	120,000	130,000	140,000	150,000
Or Years:	1	2	3	4	5	6	7	8	9	10	11	12	13	14	15
Or Kilometers:	16,000	32,000	48,000	64,000	80,000	96,000	112,000	128,000	144,000	160,000	176,000	192,000	208,000	224,000	240,000
Additional Inspections															
Completely fill the Diesel Exhaust Fluid tank.	X														
Inspect the CV/Universal joints.			X			X			X			X			
Inspect front suspension, tie rod ends, and replace if necessary.		X		X		X		X		X		X			
Inspect the front and rear axle fluid. If gear oil leakage is suspected, check the fluid level. If using your vehicle for police, taxi, fleet, off-road or frequent trailer towing change the axle fluid.		X		X		X		X		X		X		X	
Inspect the brake linings, parking brake function.		X		X		X		X		X		X		X	
Inspect the transfer case fluid.			X						X						X
Additional Maintenance															
Replace fuel filter and drain water from the fuel filter assembly.			X			X			X			X			X
Replace engine air filter.			X			X			X			X			X
Replace the air conditioning filter.		X		X		X		X		X		X		X	
Flush and replace the engine coolant at 10 years or 150,000 miles (240,000 km) whichever comes first.										X					X
Replace accessory drive belt(s).										X					
Inspect the transfer case fluid, change for any of the following: police, taxi, fleet, or frequent trailer towing.						X						X			
Change transfer case fluid.															X

WARNING!

- You can be badly injured working on or around a motor vehicle. Do only service work for which you have the knowledge and the right equipment. If you have any doubt about your ability to perform a service job, take your vehicle to a competent mechanic.
- Failure to properly inspect and maintain your vehicle could result in a component malfunction and affect vehicle handling and performance. This could cause an accident.

ADDITIONAL MAINTENANCE — B6 TO B20 BIODIESEL (1500 DIESEL)

NOTE:

- Under no circumstances should oil change intervals exceed 8,000 miles (12 875 km) or six months, whichever comes first when using Biodiesel blends greater than 5% (B5).
- The owner is required to monitor mileage for B6-B20 biodiesel, the automatic oil change indicator system does not reflect the use of biofuels.

MAINTAINING YOUR VEHICLE

Additional Maintenance Chart — B6 to B20 Biodiesel (1500 Diesel)

Mileage or time passed (whichever comes first)		10,000	20,000	30,000	40,000	50,000	60,000	70,000	80,000	90,000	100,000	110,000	120,000	130,000	140,000	150,000
Or Years:		1	2	3	4	5	6	7	8	9	10	11	12	13	14	15
Or Kilometers:		16,000	32,000	48,000	64,000	80,000	96,000	112,000	128,000	144,000	160,000	176,000	192,000	208,000	224,000	240,000
Additional B6 to B20 Maintenance			X		X		X		X		X		X		X	
Replace fuel filter and drain water from the fuel filter assembly.																

WARNING!

- You can be badly injured working on or around a motor vehicle. Do only service work for which you have the knowledge and the right equipment. If you have any doubt about your ability to perform a service job, take your vehicle to a competent mechanic.
- Failure to properly inspect and maintain your vehicle could result in a component malfunction and effect vehicle handling and performance. This could cause an accident.

MAINTAINING YOUR VEHICLE

MAINTENANCE RECORD

	Odometer	Date	Signature, Authorized Service Center
20,000 Miles (32,000 km) or 2 Years			
30,000 Miles (48,000 km) or 3 Years			
40,000 Miles (64,000 km) or 4 Years			
50,000 Miles (80,000 km) or 5 Years			
60,000 Miles (96,000 km) or 6 Years			
70,000 Miles (112,000 km) or 7 Years			
80,000 Miles (128,000 km) or 8 Years			

	Odometer	Date	Signature, Authorized Service Center
90,000 Miles (144,000 km) or 9 Years			
100,000 Miles (160,000 km) or 10 Years			
110,000 Miles (176,000 km) or 11 Years			
120,000 Miles (192,000 km) or 12 Years			
130,000 Miles (208,000 km) or 13 Years			
140,000 Miles (224,000 km) or 14 Years			
150,000 Miles (240,000 km) or 15 Years			

MAINTAINING YOUR VEHICLE

MAINTENANCE SCHEDULE — 6.7L CUMMINS® DIESEL ENGINE

CAUTION!

Failure to perform the required maintenance items may result in damage to the vehicle.

At Each Stop For Fuel

- Check the engine oil level at least 30 minutes after a fully warmed engine is shut off. Checking the oil level while the vehicle is on level ground will improve the accuracy of the oil level reading. Add oil only when the level is at or below the ADD or MIN mark.

Once A Month

- Inspect the batteries, and clean and tighten the terminals as required.
- Check the fluid levels of the coolant reservoir, brake master cylinder, and automatic transmission (if equipped), and add as needed.

At Each Oil Change

- Change the engine oil filter.
- Inspect the exhaust system.
- Check the coolant level, hoses, and clamps.
- Lubricate outer tie rod ends.

Inspection and service should also be performed anytime a malfunction is observed or suspected. Retain all receipts.

Oil Change Indicator System — Cummins® Diesel

Your vehicle is equipped with an engine oil change indicator system. This system will alert you when it is time to change your engine oil by displaying the words “Oil Change Due” on your Electronic Vehicle Information Center (EVIC) or Driver Information Display (DID). The oil change reminder will remind the owner to change the engine oil every 15,000 miles or 500 hours, whichever comes first, except for the Chassis Cab models that are using B20 biodiesel, which are 12,500 miles or 400 hours, whichever comes first. Failure to change the engine oil per the maintenance schedule can result in internal engine damage.

MAINTAINING YOUR VEHICLE

Your authorized dealer will reset the oil change indicator message after completing the scheduled oil change. If a scheduled oil change is performed by someone other than your authorized dealer, the message can be reset by referring to the steps described under “Instrument Cluster Warning Lights” in “What To Do In Emergencies” in this guide or “Electronic Vehicle Information Center (EVIC)” or “Driver Information Display (DID)” in “Understanding Your Instrument Panel” in your Owner’s Manual on the DVD for further information.

Replace the engine oil and oil filter every 15,000 miles (24 000 km) or six months, or sooner if prompted by the oil change indicator system. Under no circumstances should oil change intervals exceed 15,000 miles (24 000 km) or six months, whichever comes first.

NOTE:

- **Under no circumstances should oil change intervals exceed 15,000 miles (24,000 km) or six months or 500 Hours, whichever comes first.**
- Replace the engine oil and oil filter every 12,500 miles (20 000 km) when running B20 fuel (Chassis Cab Only).

If Chassis Cab models are operated with greater than 5% levels of Biodiesel, the oil change interval must not exceed 12,500 miles (20 000 km) under any circumstances. See the Fuel Requirements section for more information regarding operation of Chassis Cab models configured for use with Biodiesel blend (B6-B20) fuel meeting ASTM specification D-7467.

Perform Service Indicator — Cummins® Diesel

Your vehicle will require emissions maintenance at a set interval. To help remind you when this maintenance is due, the Electronic Vehicle Information Center (EVIC) or Driver information Display (DID) will display “Perform Service”. When the “Perform Service” message is displayed on the EVIC/DID it is necessary to have the emissions maintenance performed. Emissions maintenance may include replacing the Closed Crankcase Ventilation (CCV) filter element. The procedure for clearing and resetting the “Perform Service” indicator message is located in the appropriate Service Information.

MAINTAINING YOUR VEHICLE

Maintenance Chart — Cummins® Diesel Engine

Mileage or time passed (whichever comes first):	7,500	15,000	22,500	30,000	37,500	45,000	52,500	60,000	67,500	75,000	82,500	90,000	97,500	105,000	112,500	120,000	127,000	135,000	142,500	150,000	
Or Months:	6	12	18	24	30	36	42	48	54	60	66	72	78	84	90	96	102	108	114	120	
Or Kilometers:	12,000	24,000	36,000	48,000	60,000	72,000	84,000	96,000	108,000	120,000	132,000	144,000	156,000	168,000	180,000	192,000	204,000	216,000	228,000	240,000	
Change engine oil every 15,000 miles (24 000 km) or six months or 500 Hours or sooner if prompted by the oil change indicator system, whichever comes first. **	X	X	X	X	X	X	X	X	X	X	X	X	X	X	X	X	X	X	X	X	X
Additional Inspections																					
Check the Diesel Exhaust Fluid (DEF) tank, refill if necessary.	X	X	X	X	X	X	X	X	X	X	X	X	X	X	X	X	X	X	X	X	X
Rotate the tires.	X	X	X	X	X	X	X	X	X	X	X	X	X	X	X	X	X	X	X	X	X
Lubricate front drive shaft fitting (4x4).	X	X	X	X	X	X	X	X	X	X	X	X	X	X	X	X	X	X	X	X	X
Lubricate outer tie rod ends.	X	X	X	X	X	X	X	X	X	X	X	X	X	X	X	X	X	X	X	X	X
Inspect the front suspension, tie rod ends and boot seals for cracks or leaks and all parts for damage, wear, improper looseness or end play; replace if necessary.		X		X		X		X		X		X		X		X		X		X	
Inspect the brake linings.			X			X			X			X			X			X			
Inspect and adjust parking brake.			X			X			X			X			X			X			
Inspect drive belt; replace as necessary.			X			X			X			X			X			X			
Inspect wheel bearings.				X				X				X			X			X			X
Additional Maintenance																					
Replace engine fuel filter element.		X		X		X		X		X		X		X		X		X		X	
Replace chassis mounted fuel filter element.		X		X		X		X		X		X		X		X		X		X	

MAINTAINING YOUR VEHICLE

Mileage or time passed (whichever comes first):	6	12	18	24	30	36	42	48	54	60	66	72	78	84	90	96	102	108	114	120	
	12,000	24,000	36,000	48,000	60,000	72,000	84,000	96,000	108,000	120,000	132,000	144,000	156,000	168,000	180,000	192,000	204,000	216,000	228,000	240,000	
Or Months:																					
Or Kilometers:																					
Inspect the front and rear axle surfaces. If gear oil leakage is suspected, check the fluid level. If using your vehicle for police, taxi, fleet, off-road or frequent trailer towing change the axle fluid. *																					
Inspect the transfer case fluid (4x4), change for any of the following: police, taxi, fleet, or frequent trailer towing.				X				X				X				X					X
Change the transfer case fluid (4x4).																					
Change automatic transmission fluid (AS69RC transmission only).				X				X				X				X					X
Change automatic transmission fluid and filter(s) if using your vehicle for any of the following: police, fleet, or frequent trailer towing (68RFE transmission only).								X								X					
Change automatic transmission fluid and filter(s).																X					
Change the manual transmission fluid if using your vehicle for any of the following: police, fleet, or frequent trailer towing.								X								X					
Replace Crankcase Ventilation Filter (CCV).																					X
Flush and replace power steering fluid.																					X

MAINTAINING YOUR VEHICLE

Mileage or time passed (whichever comes first):	7,500	12,000	15,000	22,500	30,000	37,500	45,000	52,500	60,000	67,500	75,000	82,500	90,000	97,500	105,000	112,500	120,000	127,000	135,000	142,500	150,000	
	6	12	18	24	30	36	42	48	54	60	66	72	78	84	90	96	102	108	114	120		
Or Months:																						
Or Kilometers:																						
Flush and replace engine coolant. ***																						X
Adjust valve lash clearance.																						X

Inspection and service should also be performed anytime a malfunction is observed or suspected. Retain all receipts.

* Inspect the front and rear axle surfaces every 20,000 miles (32,000 km). If gear oil leakage is suspected, check the fluid level. If using your vehicle for police, taxi, fleet, off-road or frequent trailer towing change the axle fluid every 20,000 miles (32,000 km).

** Under no circumstances should oil change intervals exceed 15,000 miles (24 000 km) or six months or 500 Hours, whichever comes first.

CAUTION!

***The manufacturer highly recommends that all cooling system service, maintenance, and repairs be performed by your local authorized dealer.

WARNING!

- You can be badly injured working on or around a motor vehicle. Do only service work for which you have the knowledge and the right equipment. If you have any doubt about your ability to perform a service job, take your vehicle to a competent mechanic.
- Failure to properly inspect and maintain your vehicle could result in a component malfunction and effect vehicle handling and performance. This could cause an accident.

MAINTAINING YOUR VEHICLE

FUSES

Power Distribution Center

The Power Distribution Center is located in the engine compartment near the battery. This center contains cartridge fuses, micro fuses, relays, and circuit breakers. A description of each fuse and component may be stamped on the inside cover, otherwise the cavity number of each fuse is stamped on the inside cover that corresponds to the following chart.

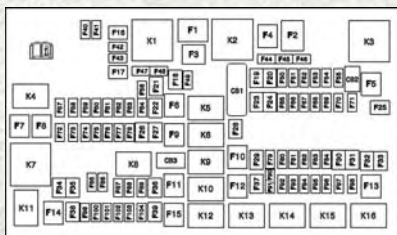

Cavity	Cartridge Fuse	Micro Fuse	Description
F01	80 Amp Black		Rad Fan Control Module – If equipped
F03	60 Amp Yellow		Rad Fan – If Equipped
F05	40 Amp Green		Compressor for Air Suspension – If Equipped
F06	40 Amp Green		Antilock Brakes/Electronic Stability Control Pump
F07	40 Amp Green		Starter Solenoid
F08	20 Amp Blue (1500 LD/ Cummins Diesel)		Emissions Diesel – If Equipped
F09	40 Amp Green (Special Services Vehicle & Cummins Diesel) 30 Amp Pink (1500 LD Diesel)		Diesel Fuel Heater – If Equipped
F10	40 Amp Green		Body Controller / Exterior Lighting #2
F10	50 Amp Red		Body Controller / Exterior Lighting #2 – If Equipped with Stop/Start
F11	30 Amp Pink		Integrated Trailer Brake Module – If Equipped
F12	40 Amp Green		Body Controller #3 / Interior Lights
F13	40 Amp Green		Blower Motor
F14	40 Amp Green		Body Controller #4 / Power Locks

MAINTAINING YOUR VEHICLE

Cavity	Cartridge Fuse	Micro Fuse	Description
F15	30 Amp Pink		Electric Park Brake Right Side – If Equipped
F16	30 Amp Pink		Smart Bar – If Equipped
F19	20 Amp Blue (1500 LD Diesel) 30 Amp Pink (Cummins Diesel)		SCR – If Equipped
F20	30 Amp Pink		Passenger Door Module
F21	30 Amp Pink		Drive Train Control Module
F22	20 Amp Blue 30 Amp Pink (Cummins Diesel)		Engine Control Module
F23	30 Amp Pink		Body Controller #1
F24	30 Amp Pink		Driver Door Module
F25	30 Amp Pink		Front Wiper
F26	30 Amp Pink		Antilock Brakes/Stability Control Module/Valves
F28	20 Amp Blue		Trailer Tow Backup Lights – If Equipped
F29	20 Amp Blue		Trailer Tow Parking Lights – If Equipped
F30	30 Amp Pink		Trailer Tow Receptacle
F31	30 Amp Pink (1500 LD Diesel)		Urea Heater Control – If Equipped
F32	30 Amp Pink		Drive Train Control Module – If Equipped
F33	20 Amp Blue		Special Services Vehicle Only
F34	30 Amp Pink		Vehicle System Interface Module #2 – If Equipped
F35	30 Amp Pink		Sunroof – If Equipped
F36	30 Amp Pink		Rear Defroster– If Equipped
F37	30 Amp Pink		Cummins Diesel Fuel Heater #2 If Equipped
F38	30 Amp Pink		Power Inverter 115V AC– If Equipped
F39	30 Amp Pink		Vehicle System Interface Module #1– If Equipped
F41		10 Amp Red	Active Grill Shutter
F42		20 Amp Yellow	Horn
F44		10 Amp Red	Diagnostic Port
F46		10 Amp Red	Tire Pressure Monitor
F49		10 Amp Red	Instrument Panel Cluster

MAINTAINING YOUR VEHICLE

Cavity	Cartridge Fuse	Micro Fuse	Description
F50		20 Amp Yellow	Air Suspension Control Module – If Equipped
F51		10 Amp Red	Ignition Node Module / Keyless Ignition
F52		5 Amp Tan	Battery Sensor
F53		20 Amp Yellow	Trailer Tow – Left Turn/Stop Lights
F54		20 Amp Yellow	Adjustable Pedals
F56		15 Amp Blue	Additional Diesel Content – If Equipped
F57		20 Amp Yellow	Transmission
F58		20 Amp Yellow	Spare Fuse
F59		10 Amp Red	SCR Relay – If Equipped
F60		15 Amp Blue	Underhood Lamp
F61		10 Amp Red (1500 LD Diesel & Cummins Diesel)	PM Sensor – If Equipped
F62		10 Amp Red	Air Conditioning Clutch
F63		20 Amp Yellow	Ignition Coils (Gas), Urea Heater (Cummins Diesel)
F64		25 Amp Clear	Fuel Injectors / Powertrain
F65		10 Amp Red	USB interface
F66		10 Amp Red	Sunroof / Passenger Window Switches / Rain Sensor
F67		10 Amp Red	CD / DVD / Bluetooth Hands-free Module – If Equipped
F69		15 Amp Blue	Mod SCR 12V (Cummins Diesel) – If Equipped
F70		30 Amp Green	Fuel Pump Motor
F71		25 Amp Clear	Amplifier
F72		10 Amp Red	Voltage Stabilizer Modules – If Equipped
F73		20 Amp Yellow	Fuel Transfer Pump (HD Only) – If Equipped
F74		20 Amp Yellow (Gas Engine & 1500 LD Diesel) 10 Amp Red (Cummins Diesel Engine)	Brake Vacuum Pump Gas/Diesel – If Equipped
F75		10 Amp Red	Coolant Temperature Valve Actuator
F76		10 Amp Red	Antilock Brakes/Electronic Stability Control

MAINTAINING YOUR VEHICLE

Cavity	Cartridge Fuse	Micro Fuse	Description
F77		10 Amp Red	Drivetrain Control Module/Front Axle Disconnect Module
F78		10 Amp Red	Engine Control Module / Electric Power Steering
F79		15 Amp Blue	Clearance Lights
F80		10 Amp Red	Universal Garage Door Opener / Compass
F81		20 Amp Yellow	Trailer Tow Right Turn/Stop Lights
F82		10 Amp Red	Steering Column Control Module/ Cruise Control
F84		15 Amp Blue	Switch Bank/Instrument Cluster
F85		10 Amp Red	Airbag Module
F86		10 Amp Red	Airbag Module
F87		10 Amp Red	Air Suspension-If Equipped / Trailer Tow / Steering Column Control Module
F88		15 Amp Blue	Instrument Panel Cluster
F90/F91		20 Amp Yellow	Power Outlet (Rear seats) Customer Selectable
F93		20 Amp Yellow	Cigar Lighter
F94		10 Amp Red	Shifter / Transfer Case Module
F95		10 Amp Red	Rear Camera / Park Assist
F96		10 Amp Red	Rear Seat Heater Switch
F97		25 Amp Clear	Rear Heated Seats & Heated Steering Wheel – If Equipped
F98		25 Amp Clear	Front Heated Seats – If Equipped
F99		10 Amp Red	Climate Control
F100		10 Amp Red	Upfitters – If Equipped
F101		15 Amp Blue	Electrochromatic Mirror / Smart High Beams – If Equipped
F104		20 Amp Yellow	Power Outlets (Instrument Panel/ Center Console)

CAUTION!

- When installing the power distribution center cover, it is important to ensure the cover is properly positioned and fully latched. Failure to do so may allow water to get into the power distribution center and possibly result in an electrical system failure.
- When replacing a blown fuse, it is important to use only a fuse having the correct amperage rating. The use of a fuse with a rating other than indicated may result in a dangerous electrical system overload. If a properly rated fuse continues to blow, it indicates a problem in the circuit that must be corrected.

MAINTAINING YOUR VEHICLE

TIRE PRESSURES

Check the inflation pressure of each tire, including the spare tire (if equipped), at least monthly and inflate to the recommended pressure for your vehicle.

The tire pressures recommended for your vehicle are found on the “Tire and Loading Information” label located on the driver’s side door opening.

NOTE:

Refer to the Owner’s Manual on the DVD for more information regarding tire warnings and instructions.

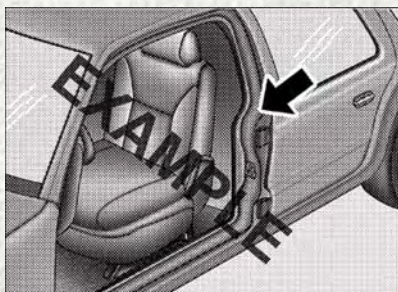

**Tire And Loading Information Location
(Example)**

WARNING!

- Overloading of your tires is dangerous. Overloading can cause tire failure, affect vehicle handling, and increase your stopping distance. Use tires of the recommended load capacity for your vehicle. Never overload them.
- Improperly inflated tires are dangerous and can cause collisions. Under-inflation increases tire flexing and can result in over-heating and tire failure. Over-inflation reduces a tire’s ability to cushion shock. Objects on the road and chuck holes can cause damage that results in tire failure. Unequal tire pressures can cause steering problems. You could lose control of your vehicle. Over-inflated or under-inflated tires can affect vehicle handling and can fail suddenly, resulting in loss of vehicle control. Always drive with each tire inflated to the recommended cold tire inflation pressure.

SPARE TIRES — IF EQUIPPED

NOTE:

For vehicles equipped with Tire Service Kit instead of a spare tire, please refer to “Tire Service Kit” in “What To Do In Emergencies” on your DVD for further information.

CAUTION!

Because of the reduced ground clearance, do not take your vehicle through an automatic car wash with a compact or limited-use temporary spare installed. Damage to the vehicle may result.

MAINTAINING YOUR VEHICLE

Spare Tire Matching Original Equipped Tire And Wheel — If Equipped

Your vehicle may be equipped with a spare tire and wheel equivalent in look and function to the original equipment tire and wheel found on the front or rear axle of your vehicle. This spare tire may be used in the tire rotation for your vehicle. If your vehicle has this option, refer to an authorized tire dealer for the recommended tire rotation pattern.

Compact Spare Tire — If Equipped

The compact spare is for temporary emergency use only. You can identify if your vehicle is equipped with a compact spare by looking at the spare tire description on the Tire and Loading Information Placard located on the driver's side door opening or on the sidewall of the tire. Compact spare tire descriptions begin with the letter "T" or "S" preceding the size designation. Example: T145/80D18 103M.

T, S = Temporary Spare Tire

Since this tire has limited tread life, the original equipment tire should be repaired (or replaced) and reinstalled on your vehicle at the first opportunity.

Do not install a wheel cover or attempt to mount a conventional tire on the compact spare wheel, since the wheel is designed specifically for the compact spare tire. Do not install more than one compact spare tire and wheel on the vehicle at any given time.

WARNING!

Compact spares are for temporary emergency use only. With these spares, do not drive more than 50 mph (80 km/h). Temporary use spares have limited tread life. When the tread is worn to the tread wear indicators, the temporary use spare tire needs to be replaced. Be sure to follow the warnings, which apply to your spare. Failure to do so could result in spare tire failure and loss of vehicle control.

Full Size Spare — If Equipped

The full size spare is for temporary emergency use only. This tire may look like the originally equipped tire on the front or rear axle of your vehicle, but it is not. This spare tire may have limited tread life. When the tread is worn to the tread wear indicators, the temporary use full size spare tire needs to be replaced. Since it is not the same as your original equipment tire, replace (or repair) the original equipment tire and reinstall on the vehicle at the first opportunity.

MAINTAINING YOUR VEHICLE

Limited-Use Spare — If Equipped

The limited-use spare tire is for temporary emergency use only. This tire is identified by a label located on the limited-use spare wheel. This label contains the driving limitations for this spare. This tire may look like the original equipped tire on the front or rear axle of your vehicle, but it is not. Installation of this limited-use spare tire affects vehicle handling. Since it is not the same as your original equipment tire, replace (or repair) the original equipment tire and reinstall on the vehicle at the first opportunity.

WARNING!

Limited-use spares are for emergency use only. Installation of this limited-use spare tire affects vehicle handling. With this tire, do not drive more than the speed listed on the limit-use spare wheel. Keep inflated to the cold tire inflation pressures listed on your Tire and Loading Information Placard located on the driver's side B-Pillar or the rear edge of the driver's side door. Replace (or repair) the original equipment tire at the first opportunity and reinstall it on your vehicle. Failure to do so could result in loss of vehicle control.

WHEEL AND WHEEL TRIM CARE

All wheels and wheel trim, especially aluminum and chrome plated wheels, should be cleaned regularly with a mild soap and water to prevent corrosion.

To remove heavy soil and/or excessive brake dust, use MOPAR® Wheel Cleaner or equivalent or select a non-abrasive, non-acidic cleaner.

CAUTION!

Do not use scouring pads, steel wool, a bristle brush, or metal polishes. Do not use oven cleaner. These products may damage the wheel's protective finish. Avoid automatic car washes that use acidic solutions or harsh brushes that may damage the wheel's protective finish. Only MOPAR® Wheel Cleaner or equivalent is recommended.

MAINTAINING YOUR VEHICLE

REPLACEMENT BULBS

All of the inside bulbs are brass or glass-wedge base. Aluminum base bulbs are not approved.

Interior Bulbs

	Bulb Number
Overhead Console Lamps	TS 212-9
Dome Lamp	7679
For lighted switches, see your authorized dealer for replacement instructions.	

Exterior Bulbs

	Bulb Number
Base Quad Headlamp – Low Beam	H11LL
Base Quad Headlamp – High Beam	9005LL
Front Turn Signal Lamp (Base Quad Headlamp)	3157NA
Premium Bi Halogen Projector Headlamp - Low Beam	HIR2LL
Premium Bi Halogen Projector Headlamp - High Beam	9005LL
Front Turn Signal Lamp (Premium Headlamp)	LED (Serviced at Authorized Dealer)
Fog Lamp (Horizontal shape)	9145
Fog Lamp (Vertical shape)	9006
Center High Mounted Stop Lamp (CHMSL)	921K
Rear Cargo Lamp	921
LED Center High Mounted Stop Lamp (CHMSL)/Cargo Lamp	LED (Serviced at Authorized Dealer)
Cab Roof Marker Lamps	194NA
Base Rear Tail/Turn and Stop Lamp	3157K
Premium Rear Tail/Turn and Stop Lamp	LED (Serviced at Authorized Dealer)
Premium Backup Lamp	7440/W21W
Rear Lamp Bar ID Marker Lamp	194
Side Marker Lamps (Dual Rear Wheels)	194
Backup Lamp	921
Rear License Plate Lamp	194

CUSTOMER ASSISTANCE

CHRYSLER GROUP LLC CUSTOMER CENTER

P.O. Box 21-8004 Auburn Hills, MI 48321-8004 Phone: 1-866-726-4636

CHRYSLER CANADA INC. CUSTOMER CENTER

P.O. Box 1621 Windsor, Ontario N9A 4H6 Phone: 1-800-465-2001 (English)
Phone: 1-800-387-9983 (French)

ASSISTANCE FOR THE HEARING IMPAIRED

To assist customers who have hearing difficulties, the manufacturer has installed special TDD (Telecommunication Devices for the Deaf) equipment at its customer center. Any hearing or speech impaired customer, who has access to a TDD or a conventional teletypewriter (TTY) in the United States, can communicate with the manufacturer by dialing 1-800-380-CHRY. Canadian residents with hearing difficulties that require assistance can use the special needs relay service offered by Bell Canada. For TTY teletypewriter users, dial 711 and for Voice callers, dial 1-800-855-0511 to connect with a Bell Relay Service operator.

WARNING!

Engine exhaust, some of its constituents, and certain vehicle components contain, or emit, chemicals known to the State of California to cause cancer and birth defects, or other reproductive harm. In addition, certain fluids contained in vehicles and certain products of component wear contain, or emit, chemicals known to the State of California to cause cancer and birth defects, or other reproductive harm.

PUBLICATIONS ORDERING

- If you are the first registered retail owner of your vehicle, you may obtain a complimentary printed copy of the Owner's Manual, Navigation/Uconnect® Manuals or Warranty Booklet. United States customers may visit the Ram Truck Contact Us page at www.ramtrucks.com scroll to the bottom of the page and select the "Contact Us" link, then select the "Owner's Manual and Glove Box Material" from the left menu. You may also obtain a complimentary copy by calling 1-866-726-4636 (U.S.) or 1-800-387-1143 (Canada).
- Replacement User Guide kits or DVDs or, if you prefer, additional printed copies of the Owner's Manual, Warranty Booklet or Radio Manuals may be purchased by visiting www.techauthority.com or by calling 1-800-890-4038 (U.S.) or 1-800-387-1143 (Canada). Visa, Master Card, American Express and Discover orders are accepted. If you prefer mailing your order, please call the above numbers for an order form.

CUSTOMER ASSISTANCE

NOTE:

- A street address is required when ordering manuals (no P.O. Boxes).
- The Owner's Manual and User Guide electronic files are also available on the Chrysler, Jeep, Ram Truck, Dodge and SRT websites.
- Click on the "For Owners" tab, select "Owner/Service Manuals", then select your desired model year and vehicle from the drop down lists.

REPORTING SAFETY DEFECTS IN THE UNITED STATES

If you believe that your vehicle has a defect that could cause a collision or cause injury or death, you should immediately inform the National Highway Traffic Safety Administration (NHTSA) in addition to notifying the manufacturer.

If NHTSA receives similar complaints, it may open an investigation, and if it finds that a safety defect exists in a group of vehicles, it may order a recall and remedy campaign. However, NHTSA cannot become involved in individual problems between you, your authorized dealer and the manufacturer.

To contact NHTSA, you may either call the Auto Safety Hotline toll free at 1-888-327-4236 (TTY: 1-800-424-9153), or go to <http://www.safercar.gov>; or write to: Administrator, NHTSA, 1200 New Jersey Avenue, SE., West Building, Washington, D.C. 20590. You can also obtain other information about motor vehicle safety from <http://www.safercar.gov>.

In Canada

If you believe that your vehicle has a safety defect, you should contact the Customer Service Department immediately. Canadian customers who wish to report a safety defect to the Canadian government should contact Transport Canada, Motor Vehicle Defect Investigations and Recalls at 1-800-333-0510 or go to <http://www.tc.gc.ca/roadsafety/>.

French Canadian customers who wish to report a safety defect to the Canadian government should contact Transport Canada, Motor Vehicle Defect Investigations and Recalls at 1-800-333-0510 or go to <http://www.tc.gc.ca/securiteroutiere/>.

AUTHENTIC ACCESSORIES BY MOPAR®

- In choosing Authentic Accessories you gain far more than expressive style, premium protection, or extreme entertainment, you also benefit from enhancing your vehicle with accessories that have been thoroughly tested and factory-approved.
- The following highlights just some of the many Authentic Ram Accessories by Mopar® featuring a fit, finish, and functionality specifically for your Ram.
- For the full line of Authentic Ram Accessories by Mopar®, visit your local dealership or online at mopar.com for U.S. residents and mopar.ca for Canadian residents.

NOTE:

All parts are subject to availability.

CHROME:

- Exhaust Tip
- Cast Aluminum Wheels
- Body Side Molding
- Tubular Side Steps
- Front Air Deflector
- Fuel Filler Door
- Grille

EXTERIOR:

- Bedliners
- Composite Tonneau Cover
- Roll-up Tonneau Cover
- Folding Tonneau Cover
- Molded Splash Guards
- Running Boards
- Bed Extender
- Bed Step
- Hitch Receiver
- Tailgate Lock
- Bed Mat & Bed Rug
- Tool Box
- Sports Performance Hood
- Body Kit

INTERIOR:

- Premium Carpet Mats
- Ambient Light Kit
- Door Sill Guards
- Bright Pedal Kit
- Slush Mats
- Heated Seats

ELECTRONICS:

- Kicker® Sound Systems
- Mopar® Web (Wi-fi)
- Remote Start
- Electronic Vehicle Tracking

CARRIERS:

- Bed Mounted Bike Carrier
- Bed Mounted Ski and Snowboard Carrier
- Cargo Bed Divider
- Bed Mounted Cargo Basket With Cargo Net
- Cargo Ramps

Kicker® is a registered trademark of Stillwater Designs and Audio, Inc.

FREQUENTLY ASKED QUESTIONS

GETTING STARTED

How do I install my LATCH Equipped Child Seat? pg. 22

How do I program my Front Seat Memory? pg. 30

OPERATING YOUR VEHICLE

How does the Electronic Range Select (ERS) operate? pg. 42

ELECTRONICS

Which radio is in my vehicle?

- Uconnect® 3.0 pg. 79
- Uconnect® 5.0 pg. 82
- Uconnect® 8.4A pg. 95
- Uconnect® 8.4AN pg. 126

How do I activate the Audio Jack?

- Uconnect® 3.0 pg. 81
- Uconnect® 5.0 pg. 85
- Uconnect® 8.4A pg. 101
- Uconnect® 8.4AN pg. 101

How do I set the clock on my radio?

- Uconnect® 3.0 pg. 79
- Uconnect® 5.0 pg. 83
- Uconnect® 8.4A pg. 95
- Uconnect® 8.4AN pg. 126

How do I use the Navigation feature?

- Uconnect® 8.4A pg. 104
- Uconnect® 8.4AN pg. 135

How do I pair my cell phone via Bluetooth® with the Uconnect® Hands-Free Voice Activation System?

- Uconnect® 8.4A pg. 139
- Uconnect® 8.4AN pg. 139

How do I use my iPod®? pg. 101

How do I use my USB port to listen to audio through my touch-screen radio? pg. 101

OFF-ROAD CAPABILITIES

How do I shift into different four-wheel drive selections? pg. 158

UTILITY

How do I know how much I can tow with my Ram Truck? pg. 168

How do I adjust the gain on the Integrated Trailer Brake Module? pg. 169

WHAT TO DO IN EMERGENCIES

How do I change a flat tire? pg. 211

How do I Jump-Start my vehicle? pg. 222

MAINTAINING YOUR VEHICLE

Where is my Fuse Block located? pg. 267

What type of oil do I use? pg. 244

How often should I change my engine's oil?

- Gasoline Engine pg. 252
- Cummins® Diesel Engine pg. 262
- 1500 Diesel Engine pg. 257

INDEX

- Access
 - Uconnect®61
- Adding Engine Coolant (Antifreeze).252
- Adding Washer Fluid252
- Adjustable Pedals35
- Air Bag
 - Advanced Front Air Bag18
 - Advance Front Air Bag17
 - Air Bags17
 - Air Bag Warning Light17, 205
 - Front Air Bag17
 - Rollover17
 - Side Impacts17
- Air Cleaner, Engine (Engine Air Cleaner Filter)252
- Air Conditioner Maintenance252
- Air Conditioning49, 50, 52, 53
- Air Conditioning Refrigerant252
- Air Conditioning System252
- Air Suspension44, 47
- Alarm
 - Arm The System15
 - Disarm The System16
 - Vehicle Security Alarm15
- Alarm (Security Alarm)15, 207
- Antifreeze (Engine Coolant)244, 252
 - Capacities247, 249
 - Disposal252
- Anti-Lock Brake System (ABS)205
- APP
 - Uconnect® Access64
- Appearance Care252
- Assistance Towing201
- Automatic Headlights38, 208
- Automatic High Beams38
- Automatic Temperature Control (ATC)52
- Automatic Transmission
 - Fluid Type246, 249, 251
- Axle Fluid246, 249, 251
- Back-Up Camera55
- Battery252
 - Charging System Light204
- Body Mechanism Lubrication252
- Brake Fluid246, 249
- Brakes252
 - Brake System252
 - Master Cylinder252
 - Warning Light203
 - Break-In Recommendations, New Vehicle36
 - Bulb Replacement274
 - Bulbs, Light274
- Calibration, Compass.148
- Capacities, Antifreeze (Engine Coolant)247, 249
- Capacities, Fluid244, 247, 249
- Caps, Filler
 - Oil (Engine)252
- Cargo Light39
- Car Washes252
- Change Oil Indicator206
- Charging System Light204
- Check Engine Light (Malfunction Indicator Light)204
- Child Restraint20
- Child Restraints
 - Lower Anchors And Tethers For Children20
- Cleaning
 - Wheels252
 - Windshield Wiper Blades252
- Climate Control49, 50, 52
- Cluster Warning/Indicator Lights
 - Air Bag Warning Light205
 - Brake Warning Light203
 - Front Fog Light Indicator207
 - Fuel Cap/Loose Gas Cap208
 - High Beam Indicator207
 - Park/Headlight ON Indicator207
 - Turn Signal Indicator207
 - Vehicle Security Light207
- Clutch252
- Clutch Fluid252
- Compact Spare Tire.272
- Compass Calibration148
- Cooling System252
 - Adding Coolant (Antifreeze)252
 - Coolant Capacity244, 247, 249
 - Coolant Level252
 - Disposal of Used Coolant252
 - Drain, Flush, and Refill252
 - Inspection252

- Points to Remember252
- Pressure Cap252
- Selection of Coolant
(Antifreeze) . .244, 245, 247, 250,
252
- Corrosion Protection252
- Cruise Control (Speed Control) . . .39
- Cruise Light39
- Customer Assistance275
- Customer Programmable
Features150
- Defects, Reporting276
- Defroster, Rear Window49, 50
- Defroster, Windshield49, 50
- Diesel Engine Maintenance . .178, 190
- Diesel Exhaust Fluid182, 195
- Diesel Fuel Water Separator . .178, 190
- Dimmer Control38
- Disabled Vehicle Towing201
- Disarming, Security System16
- Disposal
Antifreeze (Engine Coolant) . . .252
- Electronic Range Select (ERS) . .42, 43
- Electronics
Your Vehicle's Sound System . . .58
- Electronic Speed Control
(Cruise Control)39
- Electronic Stability Control (ESC) . .201
- Electronic Throttle Control Warning
Light205
- Electronic Vehicle Information
Center (EVIC)148
- Emergency, In Case of
Freeing Vehicle When Stuck . . .229
- Jump Starting222
- Overheating208
- Towing201, 228
- Engine
Air Cleaner252
- Block Heater186
- Break-In
- Recommendations . .36, 176, 186
- Checking Oil Level252
- Compartment232
- Coolant
(Antifreeze)245, 247, 250
- Cooling252
- Fuel Requirements244
- Jump Starting222
- Malfunction Indicator
(Check Engine)204
- Oil . . .244, 245, 247, 250, 252
- Oil Filler Cap252
- Oil Selection244, 252
- Overheating208
- Starting14
- Stopping14
- Event Data Recorder230
- Exhaust Brake188
- Exhaust Regeneration179
- Exhaust System252
- Filters
Air Cleaner252
- Engine Fuel178, 190
- Engine Oil . . .245, 247, 250, 252
- Engine Oil Disposal252
- Flashers
Turn Signal207
- Flat Tire Stowage220
- Fluid, Brake246, 249
- Fluid Capacities244, 247, 249
- Fluids, Lubricants and Genuine
Parts245, 247, 250
- Fog Lights38, 207
- Four Wheel Drive158
- Four Wheel Drive Operation158
- Freeing A Stuck Vehicle229
- Front And Rear ParkSense System . .54
- Front Heated Seats32
- Front ParkSense System54
- Fuel
Diesel247, 250
- Filler Cap (Gas Cap)208
- Octane Rating245
- Requirements244
- Tank Capacity244, 247, 249
- Fuse267
- Fuses267
- Garage Door Opener
(HomeLink®)152
- General Maintenance252

INDEX

- Glass Cleaning252
- Headlight38
- Headlights
 - Automatic38
 - Cleaning252
 - Dimmer Switch38
 - High Beam37
 - Switch38
- Head Restraints28
- Heated Seats31
- Heated Steering Wheel33
- Heater, Engine Block186
- High Beam Indicator207
- High Beam/Low Beam Select (Dimmer) Switch37
- HomeLink® (Garage Door Opener)152
- Hood Release231
- Hub Caps218
- Idle Up Feature189
- Instrument Cluster Indicator Lights207
- Instrument Panel Cover252
- Instrument Panel Lens Cleaning252
- Integrated Trailer Brake Controls169
- Interior and Instrument Lights7, 59
- Interior Appearance Care252
- Intermittent Wipers (Delay Wipers)37
- Introduction3
- In Vehicle Features
 - Uconnect® Access69
- Inverter Outlet (115V)155
- Inverter, Power155
- Jack Location209
- Jump Starting222
- Key Fob10
 - Arm The Alarm15
 - Disarm The Alarm16
- Keyless Enter-N-Go13
 - Lock/Unlock13
 - Starting/Stopping14
- Lane Change and Turn Signals37
- Lane Change Assist37
- Light Bulbs274
- Lights
 - Engine Temperature Warning202
 - Fog207
 - High Beam Indicator207
 - Security Alarm207
 - Service274
 - Turn Signal37
- Lower Anchors and Tether for Children (LATCH)21
- Lubrication, Body252
- Maintenance Free Battery252
- Maintenance, General252
- Maintenance Procedures252
- Maintenance Record256, 261
- Maintenance
 - Schedule252, 257, 262, 264
- Malfunction Indicator Light (Check Engine)204
- Manual Transmission
 - Lubricant Selection246
- Master Cylinder (Brakes)252
- Memory Seat30
- Message Center
 - Water in Fuel177, 187
- MOPAR® Accessories277
- Navigation104, 135
- New Vehicle Break-In
 - Period36, 176, 186
- Oil Change Indicator206, 262
- Oil Change Indicator, Reset206
- Oil, Engine245, 247, 250, 252
 - Capacity244, 247, 249
 - Change Interval252
 - Checking252
 - Disposal252
 - Filter245, 247, 250, 252
 - Filter Disposal252
 - Materials Added to252
 - Recommendation244, 252
 - Viscosity244, 252
- Oil Filter, Selection252
- Outlet
 - Power155

- Overheating, Engine208
- Paint Care252
- Panic Alarm11
- ParkSense® System, Front And
 - Rear54
- ParkSense® System, Rear54
- Pedals, Adjustable35
- Perform Service Indicator, Reset . .263
- Pickup Box161
- Placard, Tire and Loading
 - Information.271
- Power
 - Distribution Center (Fuses) . . .267
 - Glass Sunroof56
 - Inverter155
 - Outlet (Auxiliary Electrical
 - Outlet)155
 - Seats29
 - Sliding Rear Window55
- Power Steering Fluid246
- Preparation for Jacking.211
- Programmable Electronic
 - Features149
- Purchase Apps
 - Uconnect® Access65
- Rain Sensitive Wiper System37
- Rear Camera55
- Rear Heated Seats33
- Rear ParkSense System.54, 55
- Recreational Towing170
 - Shifting into Transfer Case
 - Neutral (N)173
 - Shifting out of Transfer Case
 - Neutral (N)174
- Refrigerant.252
- Remote Keyless Entry (RKE)
 - Arm The Alarm15
 - Disarm The Alarm16
- Remote Starting System15
- Replacement Bulbs.274
- Reporting Safety Defects.276
- Resetting Perform Service
 - Indicator263
- Restraint, Head.28
- Rocking Vehicle When Stuck229
- Schedule, Maintenance252, 257
- Seat Belt Maintenance.252
- Seat Belts
 - Adjustable Shoulder Belt16
 - Pretensioners16
 - Seat Belt Warning17
- Seats.29
 - Heated31
 - Lumbar Support29
 - Memory30
 - Power29
 - Ventilated31
- Security Alarm207
 - Arm The System15
 - Disarm The System16
 - Security Alarm15
- Selection of Coolant
 - (Antifreeze)245, 247, 250
- Set Up Your Via Mobile Profile
 - Uconnect®64
- Shifting
 - Transfer Case, Shifting into Transfer
 - Case Neutral (N)173
 - Transfer Case, Shifting out of
 - Transfer Case Neutral (N)174
- Shift Lever Override225
- Signals, Turn37, 207
- SIRIUS Travel Link138
- Spare Tire272, 273
- Spark Plugs245
- Speed Control
 - Accel/Decel40
- Speed Control (Cruise Control) . . .39
- Starting
 - Cold Weather177, 187
 - Remote15
- Starting Procedures
 - (Diesel Engines).176, 186
- Steering Wheel Mounted Sound
 - System Controls147
- Stuck, Freeing.229
- Sun Roof56
- Supplemental Restraint System -
 - Airbag17
- Tailgate161
- Temperature Control, Automatic
 - (ATC)52

INDEX

- Tether Anchor, Child Restraint22
- Tires
 - Air Pressure271
 - Changing211
 - Compact Spare272
 - Flat Changing211
 - Jacking211
 - Pressure Warning Light201
- Tow/Haul168
- Tow Hooks, Emergency225
- Towing
 - Disabled Vehicle228
 - Recreational170
- Towing Vehicle Behind a
 - Motorhome170
- Traction Control204
- Trailer Towing
 - Trailer and Tongue Weight168
- Transfer Case
 - Fluid246, 249, 251
- Transmission
 - Fluid246, 249, 251, 252
 - Maintenance252
 - Warning Light206
- Turbo Cool Down180, 194
- Turn Signals37, 207

- Uconnect®
 - Access61
 - Set Up Your Via Mobile Profile . .64
 - Using Access66
 - Via Mobile Apps78
- Uconnect® 3.079
- Uconnect® 5.082
- Uconnect® 8.4A95

- Uconnect® 8.4AN126
- Uconnect® Access61
 - APP64
 - In Vehicle Features69
 - Purchase Apps65
- Uconnect® Voice Command . .88, 111
- Using Access
 - Uconnect®66

- Vehicle Security Alarm Disarming . .16
- Ventilated Seats31
- Via Mobile Apps
 - Uconnect®78
- Voice Command88, 111
- Voice Recognition
 - System (VR)88, 111

- Washer
 - Adding Fluid252
- Washers, Windshield37
- Washing Vehicle252
- Water in Fuel . . .177, 178, 187, 190
- Water Separator, Diesel
 - Fuel178, 190
- Water Separator Draining . . .178, 190
- Wheel and Wheel Trim252
- Wheel and Wheel Trim Care . .252, 273
- Wheel Cover218
- Wheel Nut Torque219
- Wind Buffeting57
- Windshield Washers37
- Windshield Wiper Blades252
- Windshield Wipers37
- Wiper Blade Replacement252

This guide has been prepared to help you get quickly acquainted with your new RAM and to provide a convenient reference source for common questions. However, it is not a substitute for your Owner's Manual.

For complete operational instructions, maintenance procedures and important safety messages, please consult your Owner's Manual, Navigation/Uconnect® Manuals and other Warning Labels in your vehicle.

Not all features shown in this guide may apply to your vehicle. For additional information on accessories to help personalize your vehicle, visit www.mopar.com (U.S.), www.mopar.ca (Canada) or your local RAM dealer.

DRIVING AND ALCOHOL

Drunken driving is one of the most frequent causes of collisions. Your driving ability can be seriously impaired with blood alcohol levels far below the legal minimum. If you are drinking, don't drive. Ride with a designated non-drinking driver, call a cab, a friend, or use public transportation.

WARNING

Driving after drinking can lead to a collision. Your perceptions are less sharp, your reflexes are slower, and your judgment is impaired when you have been drinking. Never drink and then drive.

Download a FREE electronic copy of the Owner's Manual and Warranty Booklet by visiting:

WWW.RAMTRUCKS.COM/EN/OWNERS/MANUALS OR

WWW.RAMTRUCKS.COM/EN/WARRANTY (U.S.);

WWW.OWNERS.MOPAR.CA/EN (CANADA).

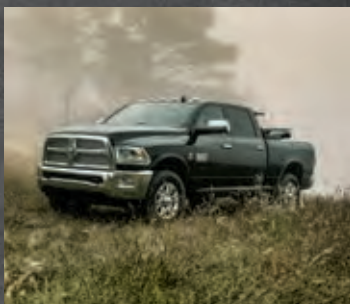
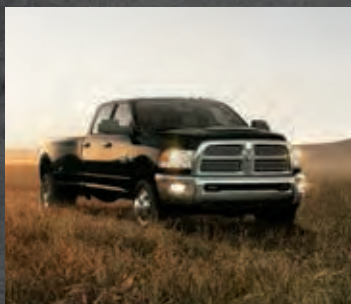

15D241-926-AA
RAM TRUCKS 1500/2500/3500
SECOND REV 1 EDITION
USER GUIDE