

Product Data Sheet

00813-0100-4001, Rev FA
August 2004

Rosemount 3051

Rosemount 3051 Pressure Transmitter

HART® AND FOUNDATION™ FIELDBUS PROTOCOLS

- *Best-in-Class performance, 0.04% High Accuracy option*
- *Industry first five-year stability under actual process conditions*
- *Unmatched Dynamic Performance*
- *Coplanar™ platform enables integrated pressure, flow, and level solutions*
- *Advanced PlantWeb® Functionality*

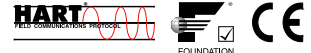

Contents

“Product Offering” page 3

“Specifications” page 4

“Product Certifications” page 11

 “HART Protocol” page 11

 “Fieldbus Protocol” page 14

“Dimensional Drawings” page 16

“Ordering Information” page 24

“HART Protocol C1 Option Configuration Data Sheet” page 38

ROSEMOUNT®

www.rosemount.com



EMERSON™
Process Management

Setting the Standard for Pressure Measurement

Industry's best total performance, a flexible *Coplanar* platform, and guaranteed 5- year stability, has made the Rosemount 3051 the standard in pressure measurement.

Industry's best total performance of $\pm 0.15\%$

Total performance is the true measure of "real-world" transmitter performance. Using superior sensor technology and engineered for optimal performance, the 3051 delivers unprecedented $\pm 0.04\%$ reference accuracy, resulting in total operating performance of $\pm 0.15\%$. Superior total performance equates to reduced variability and improved plant safety.

Five year installed stability of $\pm 0.125\%$

Transmitter stability is a critical measure of transmitter performance over time. Through aggressive simulation testing beyond standard IEC 770 testing, the 3051 has proven its ability to maintain performance over a five year period under the most demanding process conditions. Superior transmitter stability reduces calibration frequency to save operation and maintenance costs.

Unmatched dynamic performance

In dynamic applications, speed of measurement is as important as repeatability. The 3051 responds up to eight times faster than the typical pressure transmitter to detect and control variations quickly and efficiently. Superior dynamic response yields more accurate measurements to reduce variability and increase profitability.

Coplanar platform enables complete point solutions

The versatile *Coplanar* platform design enables the best process connection for pressure, flow and level applications. Right out of the box, the solution arrives factory calibrated, pressure-tested, and ready to install. Only the 3051 has a flexible design to reduce engineering and inventory costs.

Advanced *PlantWeb* Functionality



Optional functionality includes performance diagnostics and Control Anywhere™. Performance diagnostics - such as plugged impulse line detection and statistical process monitoring - go beyond the transmitter to evaluate the performance of the entire measurement system. Control Anywhere provides user-configurable transmitter-resident function blocks, such as PID, Math, and signal characterization.

Rosemount Pressure Solutions

Rosemount 3051S Series of Instrumentation

Scalable pressure, flow and level measurement solutions improve installation and maintenance practices.

Rosemount 3095MV Mass Flow Transmitter

Accurately measures differential pressure, static pressure and process temperature to dynamically calculate fully compensated mass flow.

Rosemount 305 and 306 Integral Manifolds

Factory-assembled, calibrated and seal-tested manifolds reduce on-site installation costs.

Rosemount 1199 Diaphragm Seals

Provides reliable, remote measurements of process pressure and protects the transmitter from hot, corrosive, or viscous fluids.

Orifice Plate Primary Element Systems: Rosemount 1495 and 1595 Orifice Plates, 1496 Flange Unions and 1497 Meter Sections

A comprehensive offering of orifice plates, flange unions and meter sections that is easy to specify and order. The 1595 Conditioning Orifice provides superior performance in tight fit applications.

Annubar® Flowmeter Series: Rosemount 3051SFA, 3095MFA, and 485

The state-of-the-art, fifth generation Rosemount 485 *Annubar* combined with the 3051S or 3095MV MultiVariable transmitter creates an accurate, repeatable and dependable insertion-type flowmeter.

Compact Orifice Flowmeter Series: Rosemount 3051SFC, 3095MFC, and 405

Compact Orifice Flowmeters can be installed between existing flanges, up to a Class 600 (PN100) rating. In tight fit applications, a conditioning orifice plate version is available, requiring only two diameters of straight run upstream.

ProPlate® Flowmeter Series: Rosemount *ProPlate*, Mass *ProPlate*, and 1195

These integral orifice flowmeters eliminate the inaccuracies that become more pronounced in small orifice line installations. The completely assembled, ready to install flowmeters reduce cost and simplify installation.

Product Offering

Rosemount 3051C Differential, Gage, and Absolute

See ordering information on page 24.

- Performance up to 0.04% accuracy
- Five year installed stability of 0.125%
- *Coplanar* platform enables integrated manifold, primary element and diaphragm seal solutions
- Calibrated spans/ranges from 0.1 inH₂O to 4000 psi (0,25 mbar to 276 bar)
- 316L SST, *Hastelloy*® C276, *Monel*®, Tantalum, Gold-plated *Monel*, or Gold-plated 316L SST process isolators

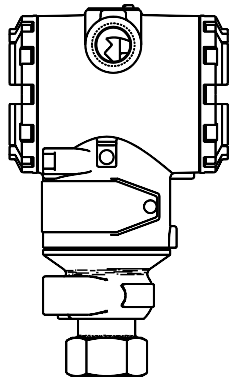
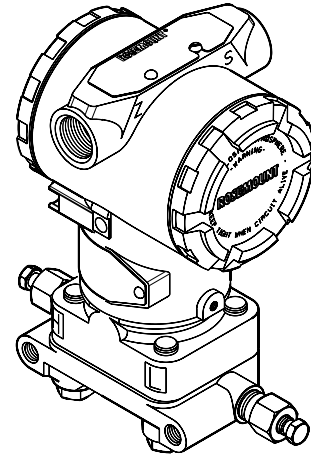

Rosemount 3051T Gage and Absolute

See ordering information on page 28.

- Performance up to 0.04% accuracy
- Five year installed stability of 0.125%
- Calibrated spans from 0.3 to 10000 psi (10,3 mbar to 689 bar)
- Multiple process connections available
- 316L SST and *Hastelloy* C276 process isolators

Rosemount 3051L Liquid Level

See ordering information on page 30.

- Performance up to 0.075% accuracy with 100:1 turndown
- Flush, 2-, 4-, and 6-in. extended diaphragms
- Multiple fill fluids available
- 316L SST, *Hastelloy* C276, or Tantalum wetted materials

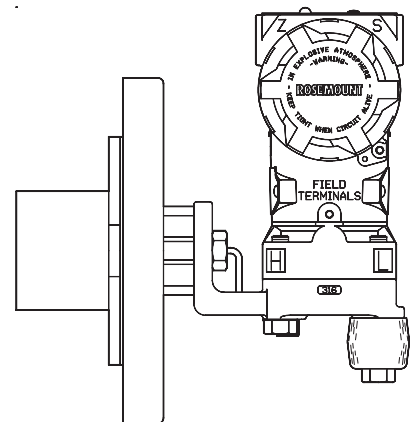

Specifications

This product data sheet covers both *HART* and fieldbus protocols unless specified.

PERFORMANCE SPECIFICATIONS⁽¹⁾

Total Performance is based on combined errors of reference accuracy, ambient temperature effect, and static pressure effect.

Rosemount 3051C (Ranges 2–5), Rosemount 3051T (Ranges 1–4)

Reference Accuracy

- ±0.065% of span
- ±0.04% of span (High Accuracy Option)

Total Performance

- ±0.15% of span for ±50 °F (28 °C) temperature changes, up to 1000 psi (6,9 MPa) line pressure (CD only), from 1:1 to 5:1 rangedown.

Stability

- ±0.125% of URL for 5 years for ±50 °F (28 °C) temperature changes, and up to 1000 psi (6,9 MPa) line pressure.

Dynamic Performance Total Response Time (T_d)

- HART* output: 100 ms
- Fieldbus and Profibus output: 152 ms

Rosemount 3051CD Low/Draft Range (Ranges 0–1)

Reference Accuracy

- ±0.10% of span

Stability

- ±0.2% of URL for 1 year

Rosemount 3051L—Liquid Level

Reference Accuracy

- ±0.075% of span

Rosemount 3051H—High Process Temperature

Reference Accuracy

- ±0.075% of span

Stability

- ±0.1% of URL for 12 months for Ranges 2 and 3.
- ±0.2% of URL for 12 months for Ranges 4 and 5.

DETAILED PERFORMANCE SPECIFICATIONS

For zero-based spans, reference conditions, silicone oil fill, SST materials, Coplanar flange (3051C) or 1/2 in.- 18 NPT (3051T) process connections, digital trim values set to equal range points.

Reference Accuracy⁽¹⁾

Stated reference accuracy includes hysteresis, terminal-based linearity and repeatability.

Rosemount 3051CD, 3051CG

Range 0 (CD)

- ±0.10% of span
- For spans less than 2:1, accuracy = ±0.05% of URL

Range 1

- ±0.10% of span
- For spans less than 15:1, accuracy =

$$\pm \left[0.025 + 0.005 \left(\frac{URL}{Span} \right) \right] \% \text{ of Span}$$

Ranges 2-5

- ±0.065% of span
- For spans less than 10:1, accuracy =

$$\pm \left[0.015 + 0.005 \left(\frac{URL}{Span} \right) \right] \% \text{ of Span}$$

Ranges 2-4 High Accuracy Option, P8

- ±0.04% of span
- For spans less than 5:1, accuracy =

$$\pm \left[0.015 + 0.005 \left(\frac{URL}{Span} \right) \right] \% \text{ of Span}$$

(1) For FOUNDATION fieldbus transmitters, use calibrated range in place of span.

Rosemount 3051CA

Ranges 1-4

±0.065% of span

For spans less than 10:1, accuracy =

$$\pm \left[0.0075 \left(\frac{URL}{Span} \right) \right] \% \text{ of Span}$$

Ranges 2-4 High Accuracy Option, P8

±0.04% of span

For spans less than 5:1, accuracy =

$$\pm \left[0.0075 \left(\frac{URL}{Span} \right) \right] \% \text{ of Span}$$

Rosemount 3051T

Ranges 1-4

±0.065% of span

For spans less than 10:1, accuracy =

$$\pm \left[0.0075 \left(\frac{URL}{Span} \right) \right] \% \text{ of Span}$$

Range 5

±0.075% of span

For spans less than 10:1, accuracy =

$$\pm \left[0.0075 \left(\frac{URL}{Span} \right) \right] \% \text{ of Span}$$

Ranges 2-4 High Accuracy Option, P8

±0.04% of span

For spans less than 5:1, accuracy =

$$\pm \left[0.0075 \left(\frac{URL}{Span} \right) \right] \% \text{ of Span}$$

Rosemount 3051H/3051L

All Ranges

±0.075% of span.

For spans less than 10:1, accuracy =

$$\pm \left[0.025 + 0.005 \left(\frac{URL}{Span} \right) \right] \% \text{ of Span}$$

Ambient Temperature Effect per 50 °F (28 °C)

Rosemount 3051CD/CG

±(0.0125% URL + 0.0625% span) from 1:1 to 5:1

±(0.025% URL + 0.125% span) from 5:1 to 100:1

Range 0: ±(0.25% URL + 0.05% span)

Range 1: ±(0.1% URL + 0.25% span)

Rosemount 3051CA

±(0.025% URL + 0.125% span) from 1:1 to 30:1

±(0.035% URL + 0.125% span) from 30:1 to 100:1

Rosemount 3051H

±(0.025% URL + 0.125% span + 0.35 inH₂O)

For spans less than 30:1

±(0.035% URL + 0.125% span + 0.35 inH₂O)

Rosemount 3051L

See Rosemount Inc. Instrument Toolkit™ software.

Rosemount 3051T

±(0.025% URL + 0.125% span) from 1:1 to 30:1

±(0.035% URL + 0.125% span) from 30:1 to 100:1

Range 5: ±(0.1% URL + 0.15% span)

Range 1: ±(0.025% URL + 0.125% span) from 1:1 to 10:1

±(0.05% URL + 0.125% span) from 10:1 to 100:1

Line Pressure Effect per 1000 psi (6,9 MPa)

Rosemount 3051CD

Zero Error (can be calibrated out at line pressure)

Range 2 – 3: ±0.05% of URL for line pressures from 0 to 2000 psi (0 to 13,7 MPa)

For line pressures above 2000 psi (13,7 MPa), see user manual (Rosemount publication number 00809-0100-4001)

Range 0: ±0.125% of URL/100 psi (6,89 bar)

Range 1: ±0.25% of URL

Span Error

Range 2 – 3: ±0.1% of reading

Range 0: ±0.15% of reading/100 psi (6,89 bar)

Range 1: ±0.4% of reading

Rosemount 3051HD

Zero Error (can be calibrated out at line pressure)

±0.1% of URL for line pressures from 0 to 2000 psi (0 to 13,7 MPa)

For line pressures above 2000 psi (13,7 MPa), see user manual (Rosemount publication number 00809-0100-4001)

Span Error

±0.1% of reading

Dynamic Performance

	4 - 20 mA (HART protocol) ⁽¹⁾	Fieldbus protocol ⁽³⁾
Total Response Time ($T_d + T_c$)⁽²⁾:		
3051C, Ranges 2-5:	100 ms	152 ms
Range 1:	255 ms	307 ms
Range 0:	700 ms	752 ms
3051T:	100 ms	152 ms
3051H/L:	Consult factory	Consult factory
Dead Time (T_d)	45 ms (nominal)	97 ms
Update Rate	22 times per second	22 times per second

(1) Dead time and update rate apply to all models and ranges; analog output only

(2) Nominal total response time at 75 °F (24 °C) reference conditions.

(3) Transmitter fieldbus output only, segment macro-cycle not included.

FIGURE 1. Typical HART Transmitter Response Time

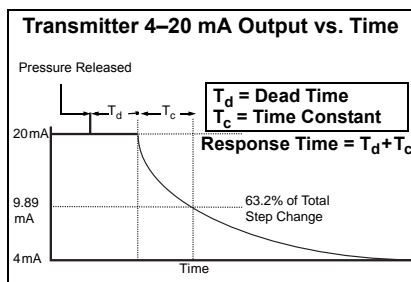

3051-3051_17A

Mounting Position Effects

Rosemount 3051C

Zero shifts up to ± 1.25 inH₂O (3,11 mbar), which can be calibrated out. No span effect.

Rosemount 3051H

Zero shifts up to ± 5 inH₂O (127 mmH₂O), which can be calibrated out. No span effect.

Rosemount 3051L

With liquid level diaphragm in vertical plane, zero shift of up to 1 inH₂O (25,4 mmH₂O).

With diaphragm in horizontal plane, zero shift of up to 5 inH₂O (127 mmH₂O) plus extension length on extended units. All zero shifts can be calibrated out. No span effect.

Rosemount 3051T/CA

Zero shifts up to 2.5 inH₂O (63,5 mmH₂O), which can be calibrated out. No span effect.

Vibration Effect

All Models

Measurement effect due to vibrations is negligible except at resonance frequencies. When at resonance frequencies, vibration effect is less than $\pm 0.1\%$ of URL per g when tested between 15 and 2000 Hz in any axis relative to pipe-mounted process conditions.

Power Supply Effect

All Models

Less than $\pm 0.005\%$ of calibrated span per volt.

RFI Effects

All Models

$\pm 0.1\%$ of span from 20 to 1000 MHz and for field strength up to 30 V/m.

Transient Protection (Option Code T1)

All Models:

Meets IEEE C62.41, Category B

6 kV crest (0.5 μ s - 100 kHz)

3 kV crest (8 \times 20 microseconds)

6 kV crest (1.2 \times 50 microseconds)

Meets IEEE C37.90.1, Surge Withstand Capability

SWC 2.5 kV crest, 1.25 MHz wave form

General Specifications:

Response Time: < 1 nanosecond

Peak Surge Current: 5000 amps to housing

Peak Transient Voltage: 100 V dc

Loop Impedance: < 25 ohms

Applicable Standards: IEC61000-4-4, IEC61000-4-5

NOTE:

Calibrations at 68 °F (20 °C) per ASME Z210.1 (ANSI)

FUNCTIONAL SPECIFICATIONS

Range and Sensor Limits

TABLE 1. 3051CD, 3051CG, 3051L, and 3051H Range and Sensor Limits

Range	Minimum Span				Range and Sensor Limits			
	3051CD ⁽¹⁾ , CG, L, H	Upper (URL)	3051C Differential	3051C/ Gage	Lower (LRL)			
					3051L Differential	3051L Gage	3051H Differential	3051H Gage
0	0.1 inH ₂ O (0,25 mbar)	3.0 inH ₂ O (7,47 mbar)	-3.0 inH ₂ O (-7,47 mbar)	NA	NA	NA	NA	NA
1	0.5 inH ₂ O (1,2 mbar)	25 inH ₂ O (62,3 mbar)	-25 inH ₂ O (-62,3 mbar)	-25 inH ₂ O (-62,3 mbar)	NA	NA	NA	NA
2	2.5 inH ₂ O (6,2 mbar)	250 inH ₂ O (0,62 bar)	-250 inH ₂ O (-0,62 bar)	-250 inH ₂ O (-0,62 bar)	-250 inH ₂ O (-0,62 bar)	-250 inH ₂ O (-0,62 bar)	-250 inH ₂ O (-0,62 bar)	-250 inH ₂ O (-0,62 bar)
3	10 inH ₂ O (24,9 mbar)	1000 inH ₂ O (2,49 bar)	-1000 inH ₂ O (-2,49 bar)	0.5 psia (34,5 mbar abs)	-1000 inH ₂ O (-2,49 bar)	0.5 psia (34,5 mbar abs)	-1000 inH ₂ O (-2,49 bar)	0.5 psia (34,5 mbar abs)
4	3 psi (0,20 bar)	300 psi (20,6 bar)	-300 psi (-20,6 bar)	0.5 psia (34,5 mbar abs)	-300 psi (-20,6 bar)	0.5 psia (34,5 mbar abs)	-300 psi (-20,6 bar)	0.5 psia (34,5 mbar abs)
5	20 psi (1,38 bar)	2000 psi (137,9 bar)	-2000 psi (-137,9 bar)	0.5 psia (34,5 mbar abs)	NA	NA	-2000 psi (-137,9 bar)	0.5 psia (34,5 mbar abs)

(1) Range 0 only available with 3051CD. Range 1 only available with 3051CD or 3051CG.

TABLE 2. Range and Sensor Limits

Range	3051CA			Range	3051T			
	Minimum Span	Upper (URL)	Lower (LRL)		Minimum Span	Upper (URL)	Lower (LRL)	Lower ⁽¹⁾ (LRL) (Gage)
1	0.3 psia (20,6 mbar)	30 psia (2,07 bar)	0 psia (0 bar)	1	0.3 psi (20,6 mbar)	30 psi (2,07 bar)	0 psia (0 bar)	-14.7 psig (-1,01 bar)
2	1.5 psia (0,103 bar)	150 psia (10,3 bar)	0 psia (0 bar)	2	1.5 psi (0,103 bar)	150 psi (10,3 bar)	0 psia (0 bar)	-14.7 psig (-1,01 bar)
3	8 psia (0,55 bar)	800 psia (55,2 bar)	0 psia (0 bar)	3	8 psi (0,55 bar)	800 psi (55,2 bar)	0 psia (0 bar)	-14.7 psig (-1,01 bar)
4	40 psia (2,76 bar)	4000 psia (275,8 bar)	0 psia (0 bar)	4	40 psi (2,76 bar)	4000 psi (275,8 bar)	0 psia (0 bar)	-14.7 psig (-1,01 bar)
				5	2000 psi (137,9 bar)	10000 psi (689,4 bar)	0 psia (0 bar)	-14.7 psig (-1,01 bar)

(1) Assumes atmospheric pressure of 14.7 psig.

Rosemount 3051

Zero and Span Adjustment Requirements (HART and Low Power)

Zero and span values can be set anywhere within the range limits stated in Table 1 and Table 2.

Span must be greater than or equal to the minimum span stated in Table 1 and Table 2.

Service

Liquid, gas, and vapor applications

4–20 mA (Output Code A)

Output

Two-wire 4–20 mA, user-selectable for linear or square root output. Digital process variable superimposed on 4–20 mA signal, available to any host that conforms to the HART protocol.

Power Supply

External power supply required. Standard transmitter (4–20 mA) operates on 10.5 to 55 V dc with no load.

Load Limitations

Maximum loop resistance is determined by the voltage level of the external power supply, as described by:

$$\text{Max. Loop Resistance} = 43.5 (\text{Power Supply Voltage} - 10.5)$$

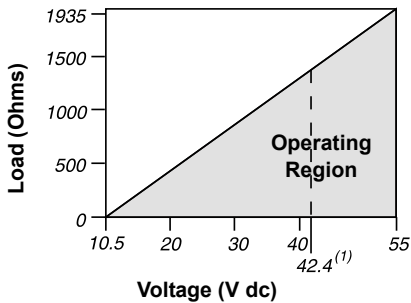

Communication requires a minimum loop resistance of 250 ohms.

(1) For CSA approval, power supply must not exceed 42.4 V.

FOUNDATION fieldbus (output code F) and Profibus (output code W)

Power Supply

External power supply required; transmitters operate on 9.0 to 32.0 V dc transmitter terminal voltage.

Current Draw

17.5 mA for all configurations (including LCD display option)

Low Power (Output Code M)

Output

Three wire 1–5 V dc or 0.8–3.2 V dc (Option Code C2) user-selectable output. Also user selectable for linear or square root output configuration. Digital process variable superimposed on voltage signal, available to any host conforming to the HART protocol. Low-power transmitter operates on 6–12 V dc with no load.

Power Consumption

3.0 mA, 18–36 mW

Minimum Load Impedance

100 k Ω (V_{out} wiring)

Indication

Optional 5-digit LCD display

Overpressure Limits

Rosemount 3051CD/CG

- Range 0: 750 psi (51,7 bar)
- Range 1: 2000 psig (137,9 bar)
- Ranges 2–5: 3626 psig (250 bar)
4500 psig (310,3 bar) for option code P9

Rosemount 3051CA

- Range 1: 120 psia (8,27 bar)
- Range 2: 300 psia (20,7 bar)
- Range 3: 1600 psia (110,3 bar)
- Range 4: 6000 psia (413,7 bar)

Rosemount 3051H

- All Ranges: 3626 psig (25 MPa)

Rosemount 3051TG/TA

- Range 1: 750 psi (51,7 bar)
- Range 2: 1500 psi (103,4 bar)
- Range 3: 1600 psi (110,3 bar)
- Range 4: 6000 psi (413,7 bar)
- Range 5: 15000 psi (1034,2 bar)

For 3051L or Level Flange Option Codes FA, FB, FC, FD, FP, and FQ, limit is 0 psia to the flange rating or sensor rating, whichever is lower.

TABLE 3. 3051L and Level Flange Rating Limits

Standard	Type	CS Rating	SST Rating
ANSI/ASME	Class 150	285 psig	275 psig
ANSI/ASME	Class 300	740 psig	720 psig
ANSI/ASME	Class 600	1480 psig	1440 psig
<i>At 100 °F (38 °C), the rating decreases with increasing temperature.</i>			
DIN	PN 10–40	40 bar	40 bar
DIN	PN 10/16	16 bar	16 bar
DIN	PN 25/40	40 bar	40 bar
<i>At 248 °F (120 °C), the rating decreases with increasing temperature.</i>			

Product Data Sheet

00813-0100-4001, Rev FA
August 2004

Rosemount 3051

Static Pressure Limit

Rosemount 3051CD Only

Operates within specifications between static line pressures of 0.5 psia and 3626 psig (4500 psig for Option Code P9).

Range 0: 0.5 psia and 750 psig

Range 1: 0.5 psia and 2000 psig

Burst Pressure Limits

Burst pressure on *Coplanar*, traditional, or 3051H process flange is 10000 psig (69 MPa).

Burst pressure for the 3051T is

Ranges 1–4: 11000 psi (75,8 MPa)

Range 5: 26000 psig (179 MPa)

Failure Mode Alarm

Output Code A

If self-diagnostics detect a gross transmitter failure, the analog signal will be driven either below 3.75 mA or to 22 mA to alert the user. NAMUR-compliant values (≤ 3.6 mA and ≥ 22.5 mA) are available, option code C4. High or low alarm signal is user-selectable by internal jumper.

Output Code M

If self-diagnostics detect a gross transmitter failure, the analog signal will be driven either below 0.94 V or above 5.4 V to alert the user (below 0.75 V or above 4.4 V for Option C2). High or low alarm signal is user-selectable by internal jumper.

Output Code F and W

If self-diagnostics detect a gross transmitter failure, that information gets passed as a status along with the process variable.

Temperature Limits

Ambient

–40 to 185 °F (–40 to 85 °C)

With integral meter: –4 to 175 °F (–20 to 80 °C)

Storage

–50 to 230 °F (–46 to 110 °C)

With integral meter: –40 to 185 °F (–40 to 85 °C)

Process

At atmospheric pressures and above. See Table 4

TABLE 4. 3051 Process Temperature Limits

3051CD, 3051CG, 3051CA	
Silicone Fill Sensor ⁽¹⁾	
with <i>Coplanar</i> Flange	–40 to 250 °F (–40 to 121 °C) ⁽²⁾
with Traditional Flange	–40 to 300 °F (–40 to 149 °C) ⁽²⁾⁽³⁾
with Level Flange	–40 to 300 °F (–40 to 149 °C) ⁽²⁾
with 305 Integral Manifold	–40 to 300 °F (–40 to 149 °C) ⁽²⁾
Inert Fill Sensor ⁽¹⁾	0 to 185 °F (–18 to 85 °C) ⁽⁴⁾⁽⁵⁾
3051H (Process Fill Fluid)	
D.C.® Silicone 200 ⁽¹⁾	–40 to 375 °F (–40 to 191 °C)
Inert ⁽¹⁾	–50 to 350 °F (–45 to 177 °C)
Neobee M-20 ⁽¹⁾	0 to 375 °F (–18 to 191 °C)
3051T (Process Fill Fluid)	
Silicone Fill Sensor ⁽¹⁾	–40 to 250 °F (–40 to 121 °C) ⁽²⁾
Inert Fill Sensor ⁽¹⁾	–22 to 250 °F (–30 to 121 °C) ⁽²⁾
3051L Low-Side Temperature Limits	
Silicone Fill Sensor ⁽¹⁾	–40 to 250 °F (–40 to 121 °C) ⁽²⁾
Inert Fill Sensor ⁽¹⁾	0 to 185 °F (–18 to 85 °C) ⁽²⁾
3051L High-Side Temperature Limits (Process Fill Fluid)	
Syltherm® XLT	–100 to 300 °F (–73 to 149 °C)
D.C. Silicone 704®	60 to 400 °F (15 to 205 °C)
D.C. Silicone 200	–40 to 400 °F (–40 to 205 °C)
Inert	–50 to 350 °F (–45 to 177 °C)
Glycerin and Water	0 to 200 °F (–18 to 93 °C)
Neobee M-20	0 to 400 °F (–18 to 205 °C)
Propylene Glycol and Water	0 to 200 °F (–18 to 93 °C)

(1) Process temperatures above 185 °F (85 °C) require derating the ambient limits by a 1.5:1 ratio (0.6:1 ratio for the 3051H).

(2) 220 °F (104 °C) limit in vacuum service; 130 °F (54 °C) for pressures below 0.5 psia.

(3) 3051CD0 process temperature limits are –40 to 212 °F (–45 to 100 °C)

(4) 160 °F (71 °C) limit in vacuum service.

(5) Not available for 3051CA.

Humidity Limits

0–100% relative humidity

Turn-On Time

Performance within specifications less than 2.0 seconds (10.0 s for Profibus protocol) after power is applied to the transmitter

Volumetric Displacement

Less than 0.005 in³ (0,08 cm³)

Damping

Analog output response to a step input change is user-selectable from 0 to 36 seconds for one time constant. This software damping is in addition to sensor module response time.

Rosemount 3051

PHYSICAL SPECIFICATIONS

Electrical Connections

$1/2$ -14 NPT, PG 13.5, $G1/2$, and $M20 \times 1.5$ (CM20) conduit. HART interface connections fixed to terminal block.

Process Connections

All Models except 3051L and 3051T

$1/4$ -18 NPT on $2 1/8$ -in. centers

$1/2$ -14 NPT on 2-, $2 1/8$ -, or $2 1/4$ -in. centers

Rosemount 3051L

High pressure side: 2-, 3-, or 4-in., ASME B 16.5 (ANSI) Class 150, 300 or 600 flange; 50, 80 or 100 mm, PN 40 or 10/16 flange

Low pressure side: $1/4$ -18 NPT on flange $1/2$ -14 NPT on adapter

Rosemount 3051T

$1/2$ -14 NPT female. A DIN 16288 Male (available in SST for Range 1-4 transmitters only), or Autoclave type F-250-C (Pressure relieved $9/16$ -18 gland thread; $1/4$ OD high pressure tube 60° cone; available in SST for Range 5 transmitters only).

Process-Wetted Parts

Drain/Vent Valves

316 SST, Hastelloy C276, or Monel material (Monel not available with 3051L or 3051H)

Process Flanges and Adapters

Plated carbon steel, SST cast CF-8M (cast version of 316 SST, material per ASTM-A743), C-Type cast alloy CW12MW, or Monel cast alloy M30C

Wetted O-rings

Glass-filled PTFE or Graphite-filled PTFE

Process Isolating Diaphragms

Isolating Diaphragm Material	3051CD/CG	3051T	3051CA	3051H
316L SST	•	•	•	•
Hastelloy C276	•	•	•	•
Monel	•		•	
Tantalum	•			•
Gold-plated Monel	•		•	
Gold-plated SST	•		•	

Rosemount 3051L Process Wetted Parts

Flanged Process Connection (Transmitter High Side)

Process Diaphragms, Including Process Gasket Surface

- 316L SST, Hastelloy C276, or Tantalum

Extension

- CF-3M (Cast version of 316L SST, material per ASTM-A743), or Hastelloy C276. Fits schedule 40 and 80 pipe.

Mounting Flange

- Zinc-cobalt plated CS or SST

Reference Process Connection (Transmitter Low Side)

Isolating Diaphragms

- 316L SST or Hastelloy C276

Reference Flange and Adapter

- CF-8M (Cast version of 316 SST, material per ASTM-A743)

Non-Wetted Parts

Electronics Housing

Low-copper aluminum or CF-3M (Cast version of 316L SST, material per ASTM-A743). NEMA 4X, IP 65, IP 66

Coplanar Sensor Module Housing

CF-3M (Cast version of 316L SST, material per ASTM-A743)

Bolts

ASTM A449, Type 1 (zinc-cobalt plated carbon steel)

ASTM F593G, Condition CW1 (Austenitic 316 SST)

ASTM A193, Grade B7M (zinc plated alloy steel)

Monel K-500

Sensor Module Fill Fluid

Silicone oil (D.C. 200) or Fluorocarbon oil (Halocarbon or Fluorinert® FC-43 for 3051T)

Process Fill Fluid (3051L and 3051H only)

3051L: Syltherm XLT, D.C. Silicone 704,

D.C. Silicone 200, inert, glycerin and water, Neobee M-20 or propylene glycol and water

3051H: inert, Neobee M-20, or D.C. Silicone 200

Paint

Polyurethane

Cover O-rings

Buna-N

Shipping Weights

Refer to "Shipping Weights" on page 37

Product Certifications

Approved Manufacturing Locations

Rosemount Inc. — Chanhassen, Minnesota USA
Emerson Process Management GmbH & Co. — Wessling, Germany
Emerson Process Management Asia Pacific Private Limited — Singapore
Beijing Rosemount Far East Instrument Co., LTD — Beijing, China

European Directive Information

The EC declaration of conformity for all applicable European directives for this product can be found on the Rosemount website at www.rosemount.com. A hard copy may be obtained by contacting an Emerson Process Management representative.

ATEX Directive (94/9/EC)

All 3051 transmitters comply with the ATEX Directive.

European Pressure Equipment Directive (PED) (97/23/EC)

3051CA4; 3051CG2, 3, 4, 5; 3051CD2, 3, 4, 5
(also with P9 option); 3051HD2, 3, 4, 5; 3051HG2, 3, 4, 5;
3051PD2, 3; and 3051PG2, 3, 4, 5 Pressure Transmitters
— QS Certificate of Assessment - EC No. PED-H-20
Module H Conformity Assessment

All other 3051/3001 Pressure Transmitters

— Sound Engineering Practice

Transmitter Attachments: Diaphragm Seal - Process Flange - Manifold

— Sound Engineering Practice

Electro Magnetic Compatibility (EMC) (89/336/EEC)

All 3051 Pressure Transmitters meet all of the requirements of IECEN61326 and NAMUR NE-21

Ordinary Location Certification for Factory Mutual

As standard, the transmitter has been examined and tested to determine that the design meets basic electrical, mechanical, and fire protection requirements by FM, a nationally recognized testing laboratory (NRTL) as accredited by the Federal Occupational Safety and Health Administration (OSHA).

HART PROTOCOL

Hazardous Locations Certifications

North American Certifications

FM Approvals

- E5** Explosion-Proof for Class I, Division 1, Groups B, C, and D. Dust-Ignition-Proof for Class II, Division 1, Groups E, F, and G. Dust-Ignition-Proof for Class III, Division 1. T5 (Ta = 85 °C), Factory Sealed, Enclosure Type 4X
- I5** Intrinsically Safe for use in Class I, Division 1, Groups A, B, C, and D; Class II, Division 1, Groups E, F, and G; Class III, Division 1 when connected per Rosemount drawing 03031-1019; Non-incendive for Class I, Division 2, Groups A, B, C, and D. Temperature Code:T4 (Ta = 40 °C), T3 (Ta = 85 °C), Enclosure Type 4X
For input parameters see control drawing 03031-1019.

Canadian Standards Association (CSA)

- E6** Explosion-Proof for Class I, Division 1, Groups B, C, and D. Dust-Ignition-Proof for Class II and Class III, Division 1, Groups E, F, and G. Suitable for Class I, Division 2 Groups A, B, C, and D for indoor and outdoor hazardous locations. Enclosure type 4X, factory sealed
- C6** Explosion-Proof and intrinsically safe approval. Intrinsically safe for Class I, Division 1, Groups A, B, C, and D when connected in accordance with Rosemount drawings 03031-1024. Temperature Code T3C. Explosion-Proof for Class I, Division 1, Groups B, C, and D. Dust-Ignition-Proof for Class II and Class III, Division 1, Groups E, F, and G. Suitable for Class I, Division 2 Groups A, B, C, and D hazardous locations. Enclosure type 4X, factory sealed
For input parameters see control drawing 03031-1024.

European Certifications

- I1** ATEX Intrinsic Safety and Dust
 Certification No.: BAS 97ATEX1089X  II 1 GD
 EEx ia IIC T5 ($-60 \leq T_a \leq +40 \text{ }^\circ\text{C}$)
 EEx ia IIC T4 ($-60 \leq T_a \leq +70 \text{ }^\circ\text{C}$)
 Dust Rating: T80 $^\circ\text{C}$ ($-20 \leq T_a \leq 40 \text{ }^\circ\text{C}$) IP66
CE 1180

TABLE 5. Input Parameters

$$U_i = 30\text{V}$$

$$I_i = 200 \text{ mA}$$

$$P_i = 0.9\text{W}$$

$$C_i = 0.012 \text{ } \mu\text{F}$$

Special Conditions for Safe Use (X):

When the optional transient protection terminal block is installed, the apparatus is not capable of withstanding the 500V insulation test required by Clause 6.4.12 of EN50020:1994. This must be taken into account when installing the apparatus.

- N1** ATEX Type n and Dust
 Certification No.: BAS 00ATEX3105X  II 3 GD
 EEx nL IIC T5 ($-40 \leq T_a \leq +70 \text{ }^\circ\text{C}$)
 $U_i = 55 \text{ Vdc max}$
 Dust rating: T80 $^\circ\text{C}$ ($-20 \leq T_a \leq 40 \text{ }^\circ\text{C}$) IP66
CE

Special Conditions for Safe Use (X):

When the optional transient protection terminal block is installed, the apparatus is not capable of withstanding a 500V r.m.s. test to case. This must be taken into account on any installation in which it is used, for example by assuring that the supply to the apparatus is galvanically isolated.

- E8** ATEX Flame-Proof and Dust
 Certification No.: KEMA 00ATEX2013X  II 1/2 GD
 EEx d IIC T6 ($-50 \leq T_a \leq 65 \text{ }^\circ\text{C}$)
 EEx d IIC T5 ($-50 \leq T_a \leq 80 \text{ }^\circ\text{C}$)
 Dust rating T90 $^\circ\text{C}$, IP66
CE 1180
 $V_{\text{max}} = 55 \text{ V dc}$

Special Conditions for Safe Use (X):

This device contains a thin wall diaphragm. Installation, maintenance, and use shall take into account the environmental conditions to which the diaphragm will be subjected. The manufacturer's instructions for installation and maintenance shall be followed in detail to assure safety during its expected lifetime.

Japanese Certifications

- E4** JIS Flame-Proof
 Ex d IIC T6

Certificate	Description
C15850	3051C/D/1 4–20 mA HART — no meter
C15851	3051C/D/1 4–20 mA HART — with meter
C15854	3051T/G/1 4–20 mA HART, SST, Silicon — no meter
C15855	3051T/G/1 4–20 mA HART, Hastelloy C276, Silicon — no meter
C15856	3051T/G/1 4–20 mA HART, SST, Silicon — with meter
C15857	3051T/G/1 4–20 mA HART, Hastelloy C276, Silicon — with meter

- I4** JIS Intrinsic Safety
 Ex ia IIC T4

Certificate	Description
C16406	3051CD/CG

Australian Certifications

- I7** SAA Intrinsic Safety
 Certification No.: AUS Ex 1249X
 Ex ia IIC T4 ($T_{\text{amb}} = 70 \text{ }^\circ\text{C}$)
 Ex ia IIC T5 ($T_{\text{amb}} = 40 \text{ }^\circ\text{C}$)
 IP66

When connected per Rosemount drawing 03031-1026

TABLE 6. Input Parameters

$$U_i = 30\text{V}$$

$$I_i = 200 \text{ mA}$$

$$I_i = 160 \text{ mA (output code A with T1)}$$

$$P_i = 0.9\text{W}$$

$$C_i = 0.01 \text{ } \mu\text{F}$$

$$C_i = 0.042 \text{ } \mu\text{F (output code M)}$$

$$L_i = 10 \text{ } \mu\text{H}$$

$$L_i = 1.05 \text{ mH (output code A with T1)}$$

$$L_i = 0.75 \text{ mH (output code M with T1)}$$

Special Conditions for Safe Use (X):

The apparatus may only be used with a passive current limited power source Intrinsic Safety application. The power source must be such that $P_o \leq (U_o * I_o) / 4$. Modules using transient protection in the terminal assembly (T1 transient protection models) the apparatus enclosure is to be electrically bonded to the protective earth. The conductor used for the connection shall be equivalent to a copper conductor of 4 mm² minimum cross-sectional area.

Product Data Sheet

00813-0100-4001, Rev FA
August 2004

Rosemount 3051

E7 SAA Explosion-Proof (Flame-Proof)
Certification No.: AUS Ex 03.1347X
Ex d IIC T6 ($T_{amb} = 40\text{ }^{\circ}\text{C}$)
Ex d IIC T5 ($T_{amb} = 80\text{ }^{\circ}\text{C}$)
DIP A21 T6 ($T_{amb} = 40\text{ }^{\circ}\text{C}$)
DIP A21 T5 ($T_{amb} = 80\text{ }^{\circ}\text{C}$)
IP66

Special Conditions for Safe Use (X):

It is a condition of safe use for transmitter enclosures having cable entry thread other than metric conduit thread that the equipment be utilized with an appropriate certified thread adaptor.

N7 SAA Type n (Non-sparking)
Certification No.: AUS Ex 1249X
Ex n IIC T4 ($T_{amb} = 70\text{ }^{\circ}\text{C}$)
Ex n IIC T5 ($T_{amb} = 40\text{ }^{\circ}\text{C}$)
IP66

Special Conditions for Safe Use (X):

Where the equipment is installed such that there is an unused conduit entry, it must be sealed with a suitable blanking plug to maintain the IP40 degree of protection. Any blanking plug used with the equipment shall be of a type which requires the use of a tool to effect its removal. Voltage source shall not exceed 60V ac or 75V dc.

Combinations of Certifications

Stainless steel certification tag is provided when optional approval is specified. Once a device labeled with multiple approval types is installed, it should not be reinstalled using any other approval types. Permanently mark the approval label to distinguish it from unused approval types.

- K5** E5 and I5 combination
- KB** K5 and C6 combination
- KD** K5, C6, I1, and E8 combination
- K6** C6, I1, and E8 combination
- K8** E8 and I1 combination
- K7** E7, I7, and N7 combination

Rosemount 3051

FIELDBUS PROTOCOL

Hazardous Locations Certifications

North American Certifications

FM Approvals

E5 Explosion-Proof for Class I, Division 1, Groups B, C, and D.
Dust-Ignition-Proof for Class II, Division 1, Groups E, F, and G.
Dust-Ignition-Proof for Class III, Division 1.

T5 (Ta = 85 °C), Factory Sealed, Enclosure Type 4X

I5 Intrinsically Safe for use in Class I, Division 1, Groups A, B, C, and D; Class II, Division 1, Groups E, F, and G; Class III, Division 1 when connected per Rosemount drawing 03031-1019; Non-incendive for Class I, Division 2, Groups A, B, C, and D.

Temperature Code:T4 (Ta = 40 °C), T3 (Ta = 85 °C),
Enclosure Type 4X

For input parameters see control drawing 03031-1019.

Canadian Standards Association (CSA)

E6 Explosion-Proof for Class I, Division 1, Groups B, C, and D.
Dust-Ignition-Proof for Class II and Class III, Division 1,
Groups E, F, and G. Suitable for Class I, Division 2 Groups
A, B, C, and D for indoor and outdoor hazardous locations.
Enclosure type 4X, factory sealed

C6 Explosion-Proof and intrinsically safe approval. Intrinsically
safe for Class I, Division 1, Groups A, B, C, and D when
connected in accordance with Rosemount drawings
03031-1024. Temperature Code T3C.

Explosion-Proof for Class I, Division 1, Groups B, C, and D.
Dust-Ignition-Proof for Class II and Class III, Division 1,
Groups E, F, and G. Suitable for Class I, Division 2 Groups
A, B, C, and D hazardous locations. Enclosure type 4X,
factory sealed

For input parameters see control drawing 03031-1024.

European Certifications

I1 ATEX Intrinsic Safety and Dust
Certification No.: BAS 98ATEX1355X  II 1 GD
EEx ia IIC T4 (T_{amb} = -60 to +60 °C)
Dust Rating: T70 °C (T_{amb} -20 to 40 °C) IP66
CE 1180

TABLE 7. Input Parameters

U_i = 30V

I_i = 300 mA

P_i = 1.3 W

C_i = 0 μF

Special Conditions for Safe Use (X):

The device is not capable of withstanding the 500V
insulation test required by Clause 6.4.12 of EN50020:1994.
This must be taken into account when installing the
apparatus.

IA ATEX FISCO Intrinsic Safety
Certification No.: BAS 98ATEX1355X  II 1 G
EEx ia IIC T4 (T_{amb} = -60 to +60 °C)
IP66

CE 1180

TABLE 8. Input Parameters

U_i = 17.5 V

I_i = 380 mA

P_i = 5.32 W

C_i = ≤ 5 μF

L_i = ≤ 10 μH

Special Conditions for Safe Use (X):

The device is not capable of withstanding the 500V
insulation test required by Clause 6.4.12 of EN50020:1994.
This must be taken into account when installing the
apparatus.

N1 ATEX Type n and Dust
Certification No.: BAS 98ATEX3356X  II 3 GD
EEx nL IIC T5 (T_{amb} = -40 to +70 °C)
U_i = 40 Vdc max
Dust rating: T80 °C (T_{amb} = -20 to 40 °C) IP66

Special Conditions for Safe Use (X):

The device is not capable of withstanding the 500V
insulation test required by Clause 6.4.12 of EN50020:1994.
This must be taken into account when installing the
apparatus.

E8 ATEX Flame-Proof and Dust
Certification No.: KEMA 00ATEX2013X  II 1/2 GD
EEx d IIC T6 (T_{amb} = -50 to 65 °C)
EEx d IIC T5 (T_{amb} = -50 to 80 °C)
Dust rating T90 °C, IP66
CE 1180
V_{max} = 55 V dc

Special Conditions for Safe Use (X):

This device contains a thin wall diaphragm. Installation,
maintenance, and use shall take into account the
environmental conditions to which the diaphragm will be
subjected. The manufacturer's instructions for installation
and maintenance shall be followed in detail to assure safety
during its expected lifetime.

Japanese Certifications

E4 JIS Flame-Proof
 Ex d IIC T6

Certificate	Description
C15852	3051C/D/1 FOUNDATION Fieldbus — no meter
C15853	3051C/D/1 FOUNDATION Fieldbus — with meter
C15858	3051T/G/1 FOUNDATION Fieldbus, SST, Silicon — no meter
C15859	3051T/G/1 FOUNDATION Fieldbus, Hastelloy C276, Silicon — no meter
C15860	3051T/G/1 FOUNDATION Fieldbus, SST, Silicon — with meter
C15861	3051T/G/1 FOUNDATION Fieldbus, Hastelloy C276, Silicon — with meter

Australian Certifications

I7 SAA Intrinsic Safety
 Certification No.: AUS Ex 1249X
 Ex ia IIC T4 (T_{amb} = 60 °C)
 IP66

When connected per Rosemount drawing 03031-1026.

TABLE 9. Input Parameters

U_i = 30 V

I_i = 300 mA

P_i = 1.3 W

C_i = 0 µF

L_i = 0 µH

Special Conditions for Safe Use (X):

The apparatus may only be used with a passive current limited power source Intrinsic Safety application. The power source must be such that $P_o \leq (U_o * I_o) / 4$. Modules using transient protection in the terminal assembly (T1 transient protection models) the apparatus enclosure is to be electrically bonded to the protective earth. The conductor used for the connection shall be equivalent to a copper conductor of 4 mm² minimum cross-sectional area.

E7 SAA Explosion-Proof (Flame-Proof)
 Certification No.: AUS Ex 1347X
 Ex d IIC T6 (T_{amb} = 40 °C)
 Ex d IIC T5 (T_{amb} = 80 °C)
 DIP A21 T6 (T_{amb} = 40 °C)
 DIP A21 T5 (T_{amb} = 80 °C)
 IP65

Special Conditions for Safe Use (X):

It is a condition of safe use for transmitter enclosures having cable entry thread other than metric conduit thread that the equipment be utilized with an appropriate certified thread adaptor.

N7 SAA Type n (Non-sparking)
 Certification No.: AUS Ex 1249X
 Ex n IIC T4 (T_{amb} = 70 °C)
 Ex n IIC T5 (T_{amb} = 40 °C)
 IP66

Special Conditions for Safe Use (X):

Where the equipment is installed such that there is an unused conduit entry, it must be sealed with a suitable blanking plug to maintain the IP40 degree of protection. Any blanking plug used with the equipment shall be of a type which requires the use of a tool to effect its removal. Voltage source shall not exceed 60V ac or 75V dc.

Combinations of Certifications

Stainless steel certification tag is provided when optional approval is specified. Once a device labeled with multiple approval types is installed, it should not be reinstalled using any other approval types. Permanently mark the approval label to distinguish it from unused approval types.

- K5** E5 and I5 combination
- KB** K5 and C6 combination
- KD** K5, C6, I1, and E8 combination
- K6** C6, I1, and E8 combination
- K8** E8 and I1 combination
- K7** E7, I7, and N7 combination

Dimensional Drawings

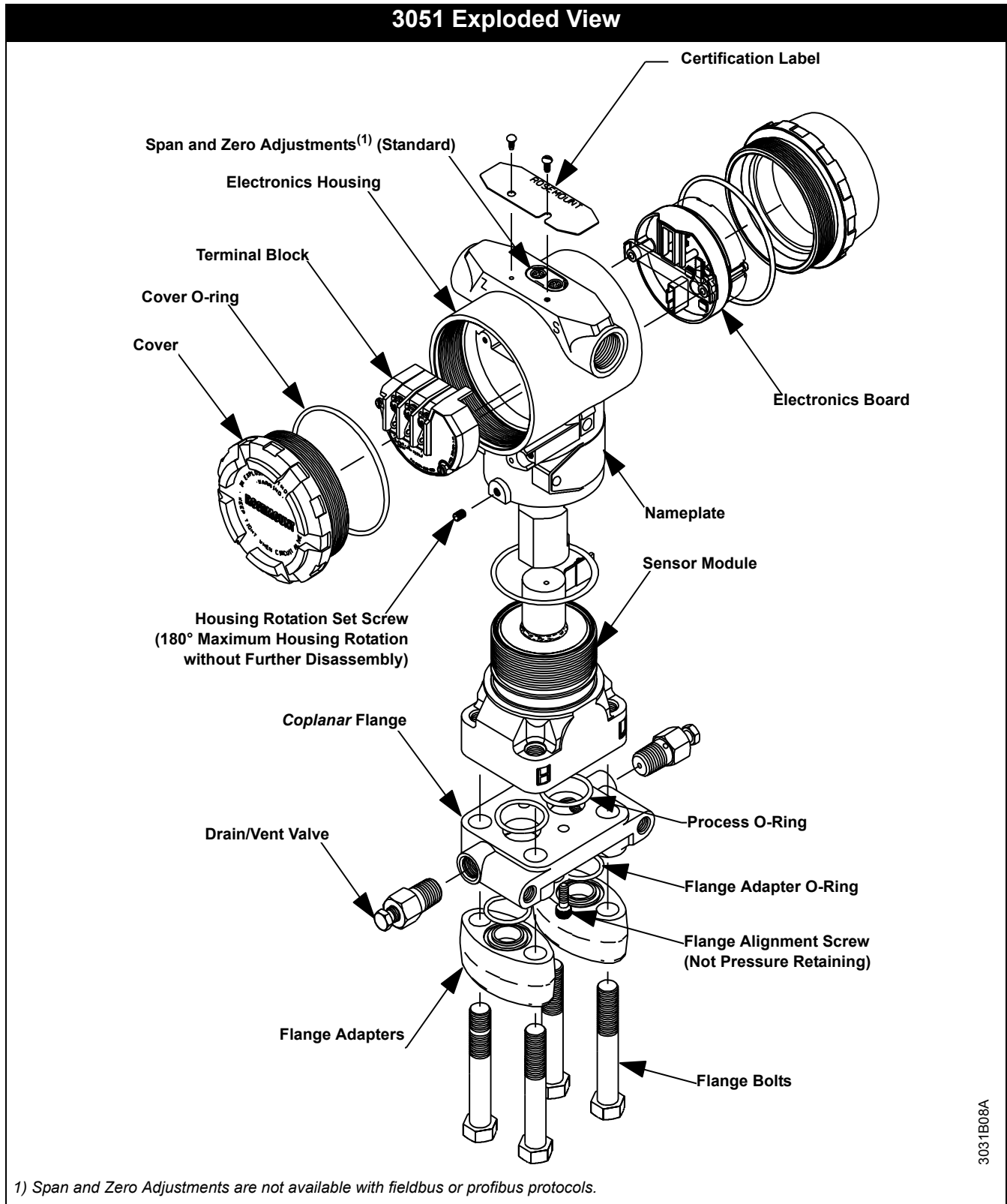

**3051C Coplanar Flange Dimensional Drawing
 (Differential Pressure Transmitter Shown)**

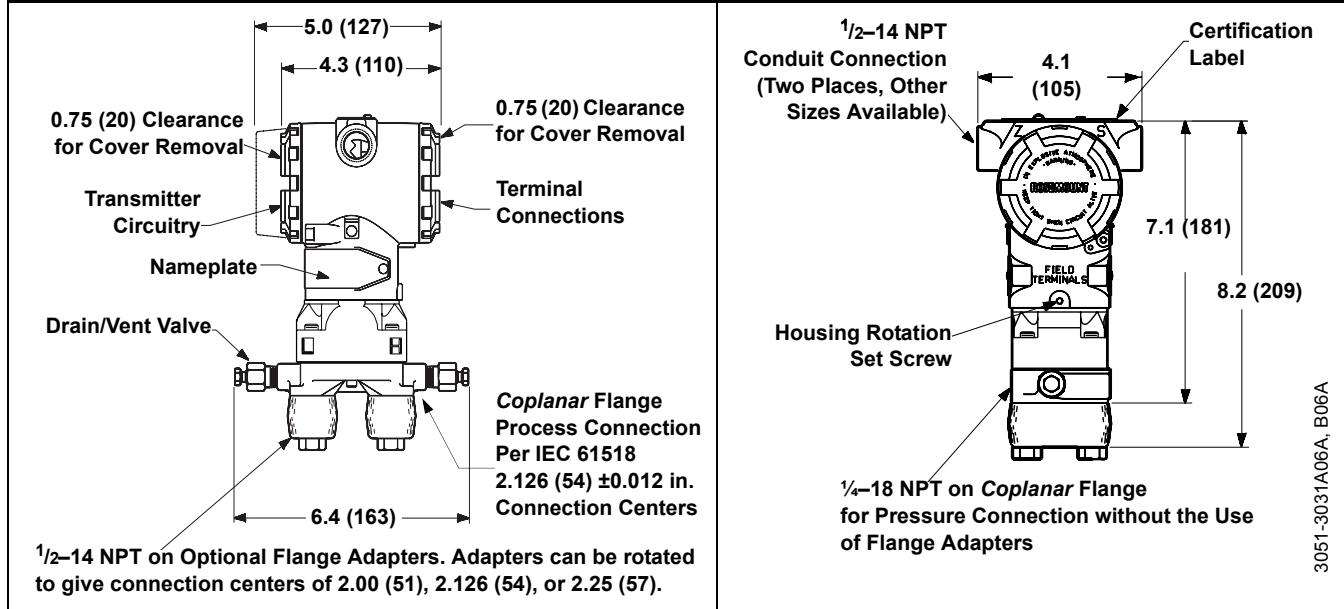

3051-3031A06A, B06A

**Coplanar Flange Mounting Configurations with
 Optional Bracket (B4) for 2-in. Pipe or Panel Mounting**

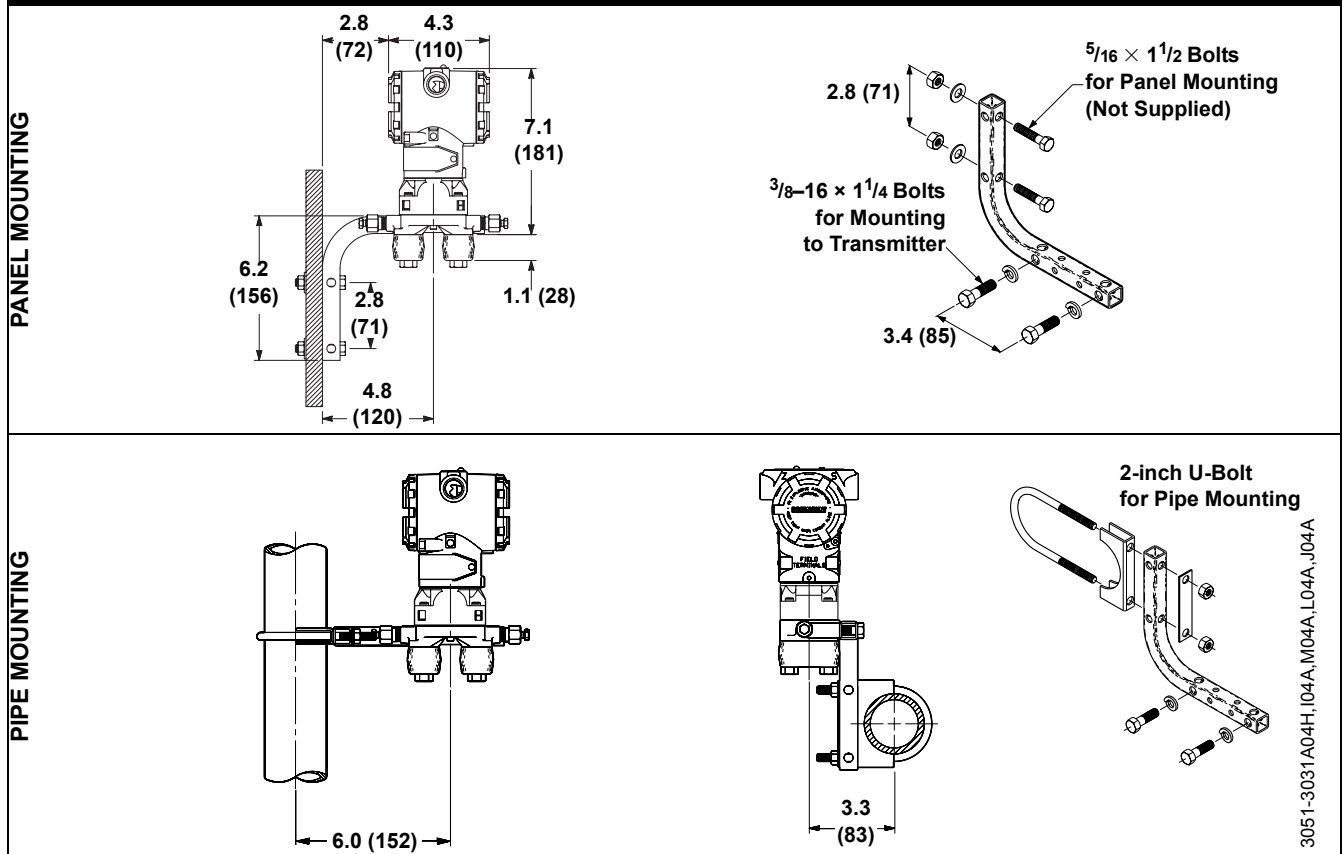

3051-3031A04H, I04A, M04A, L04A, J04A

Dimensions are in inches (millimeters)

Traditional Flange Mounting Configurations with Optional Brackets for 2-in. Pipe or Panel Mounting

Traditional Flange Panel Mounting Bracket (option B2/B8)

Traditional Flange 2-in. Pipe Mounting Bracket (option B1/B7/BA)

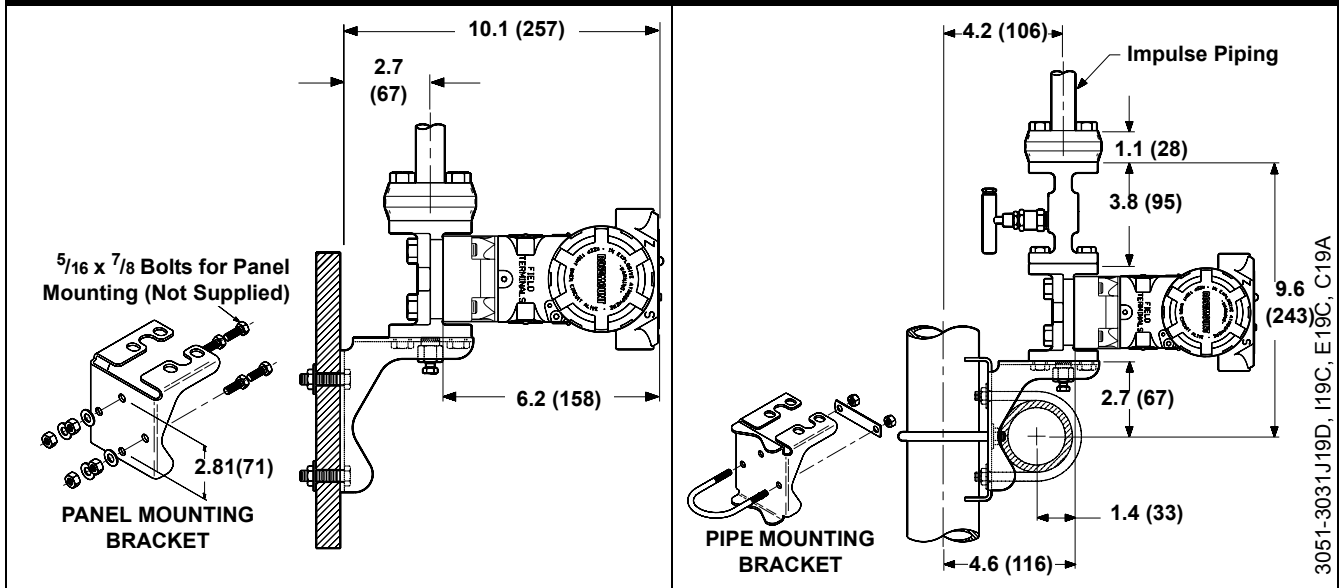

3051-3031J19D, I19C, E19C, C19A

Traditional Flange (Options H2-H7) Dimensional Drawing

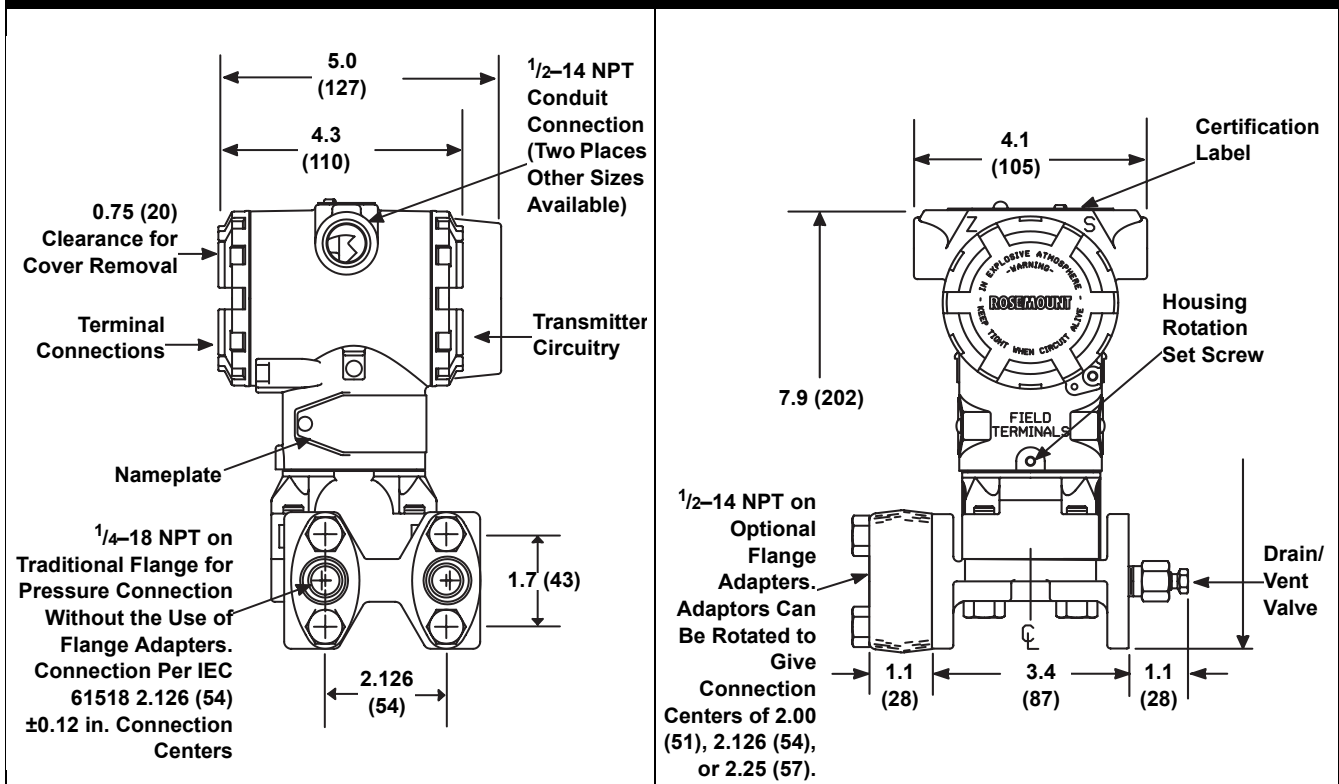

3051-3031E30A, D30B

Dimensions are in inches (millimeters)

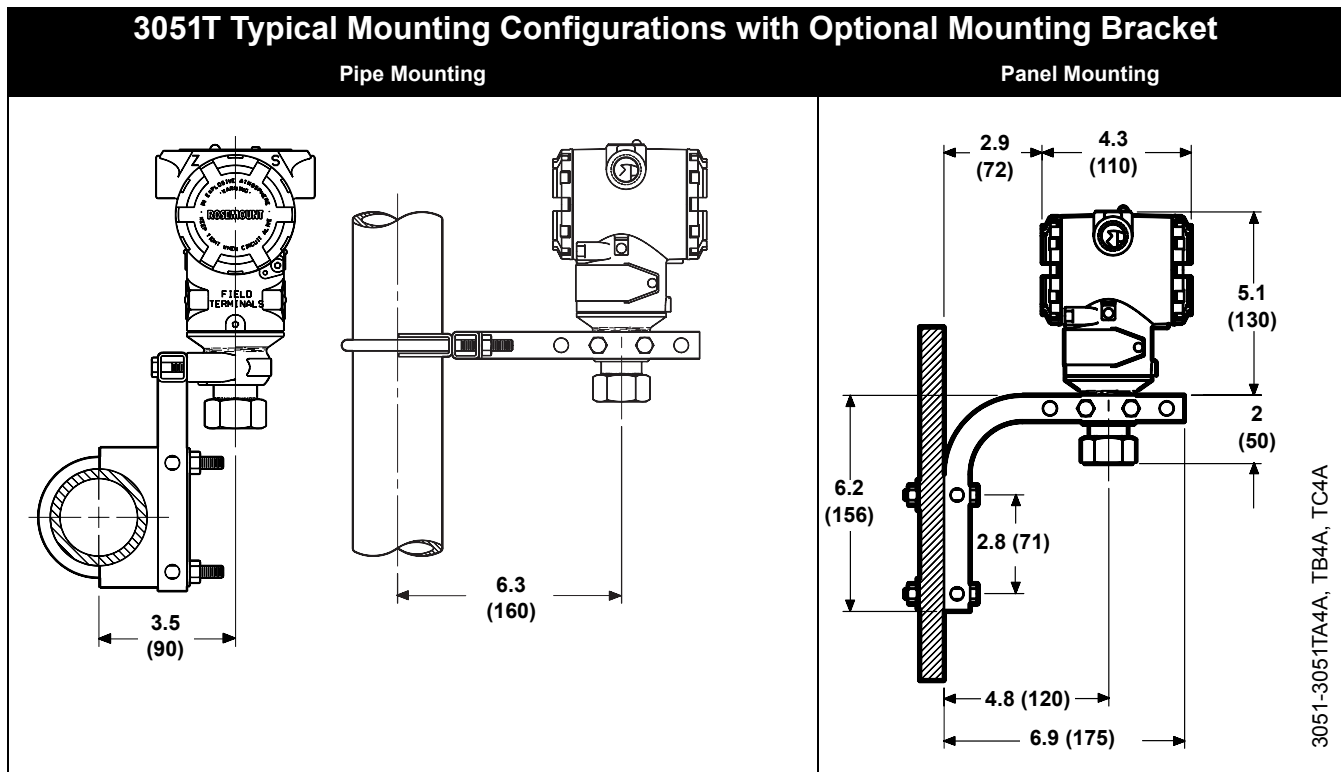
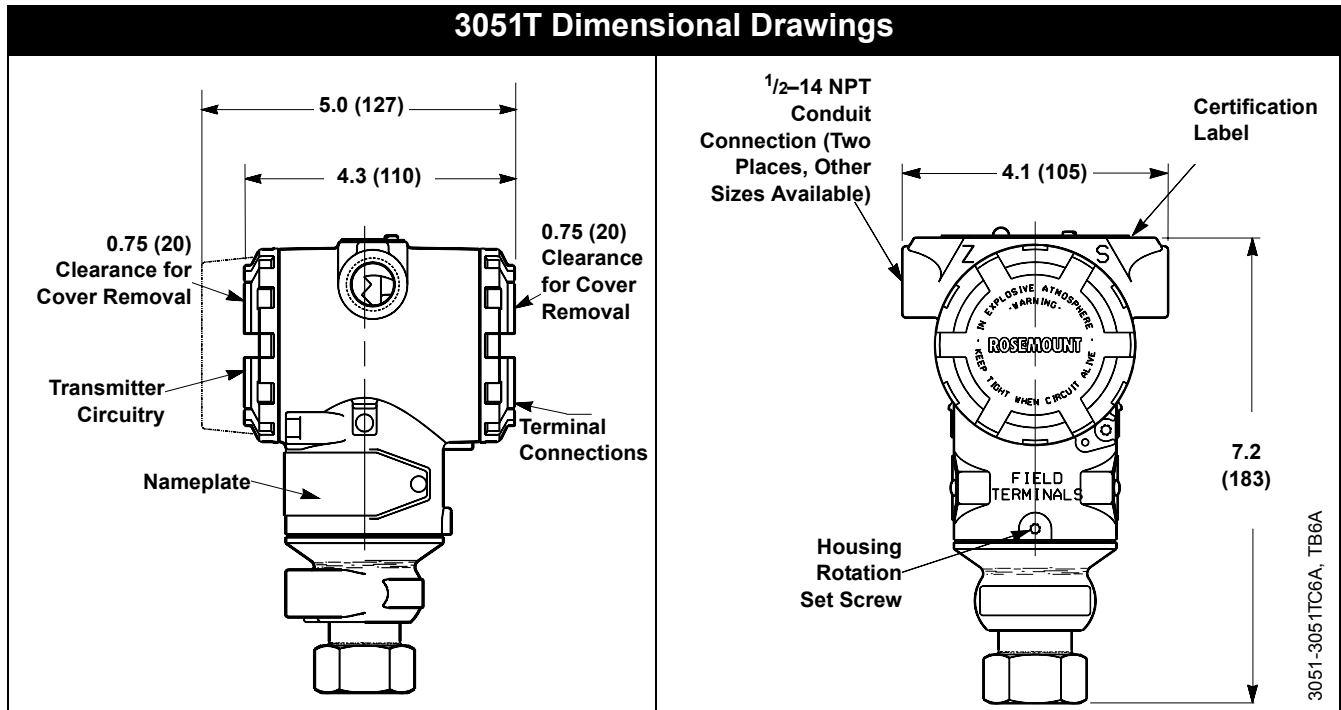

Dimensions are in inches (millimeters)

3051H Pressure Transmitter Exploded View and Dimensional Drawings

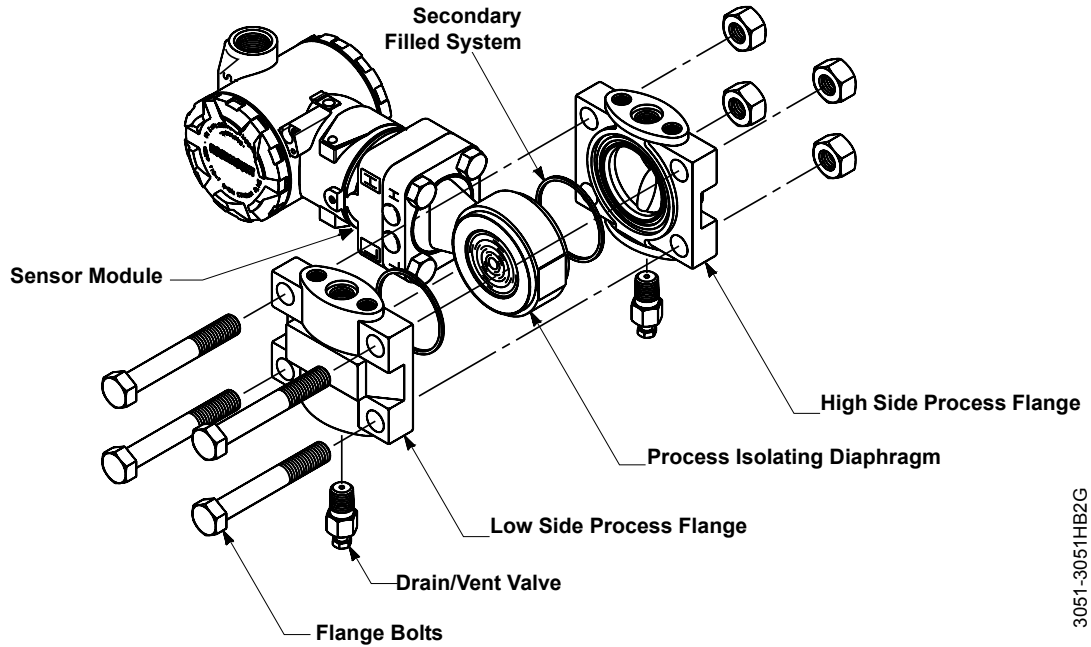

3051-3051HB2G

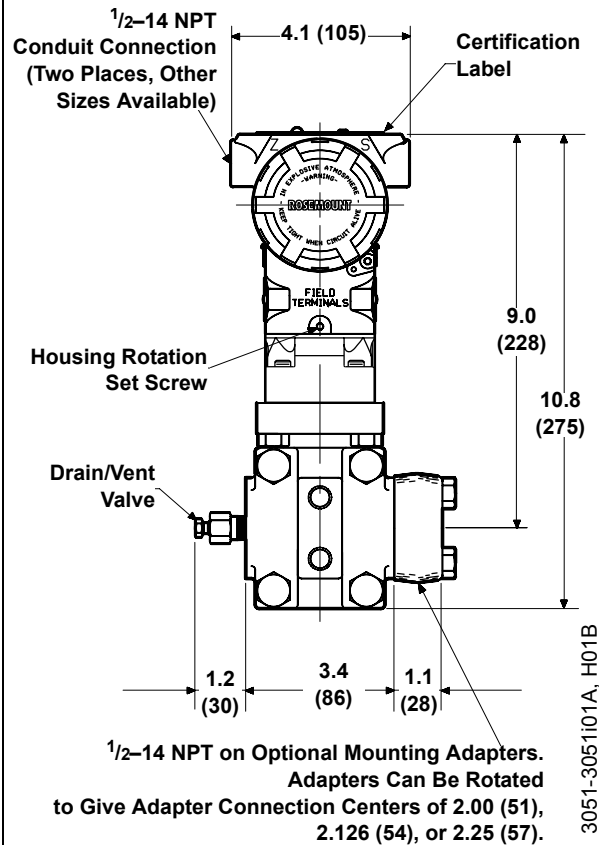
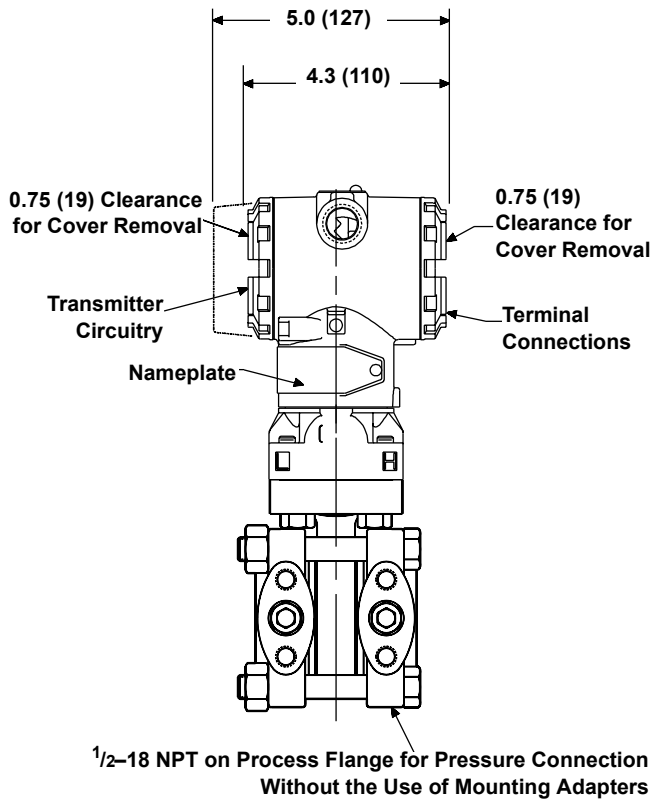

3051-3051101A, H01B

Dimensions are in inches (millimeters)

3051H Mounting Brackets for 2-in. Pipe and Panel Mount (Option Code B5/B6)

PIPE MOUNTING CONFIGURATION

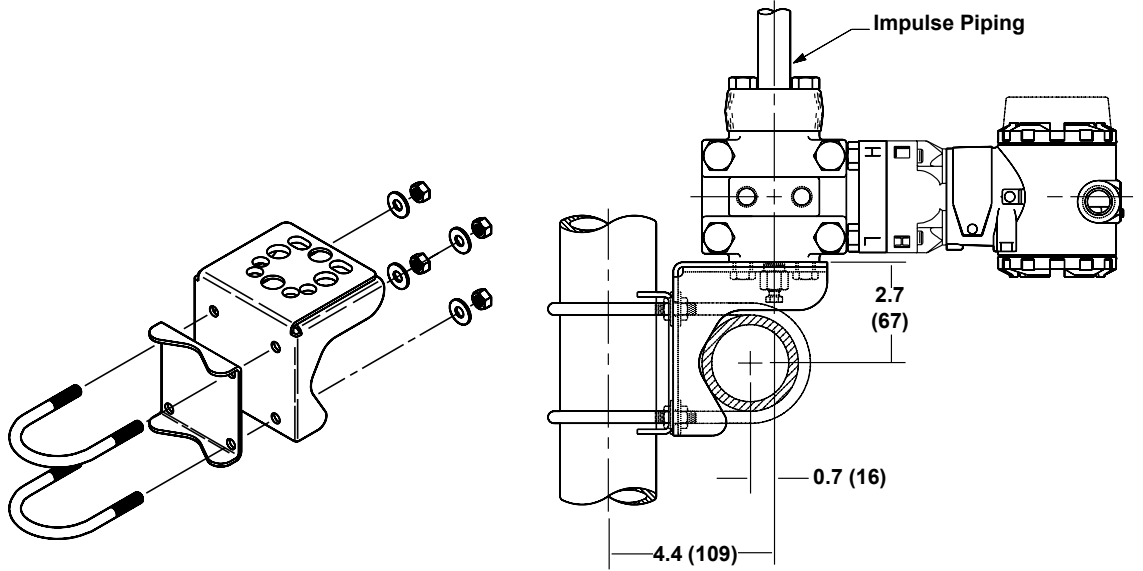

PANEL MOUNTING CONFIGURATION

7/16-20 x 3/4 Bolts Supplied for Attaching Bracket to Transmitter

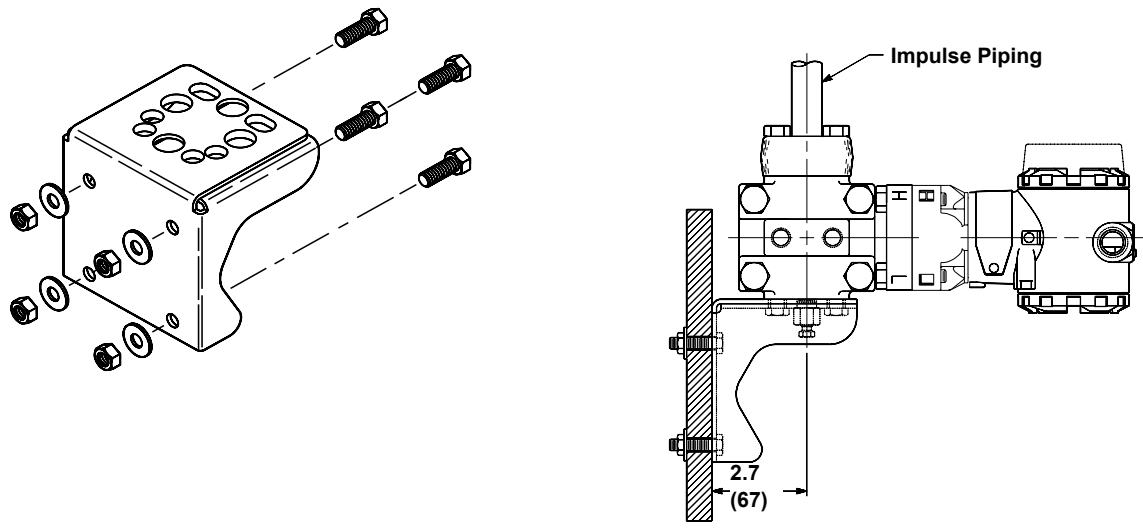

3051-3031G19A, F19B, 3051HB3A, HA3B

Dimensions are in inches (millimeters)

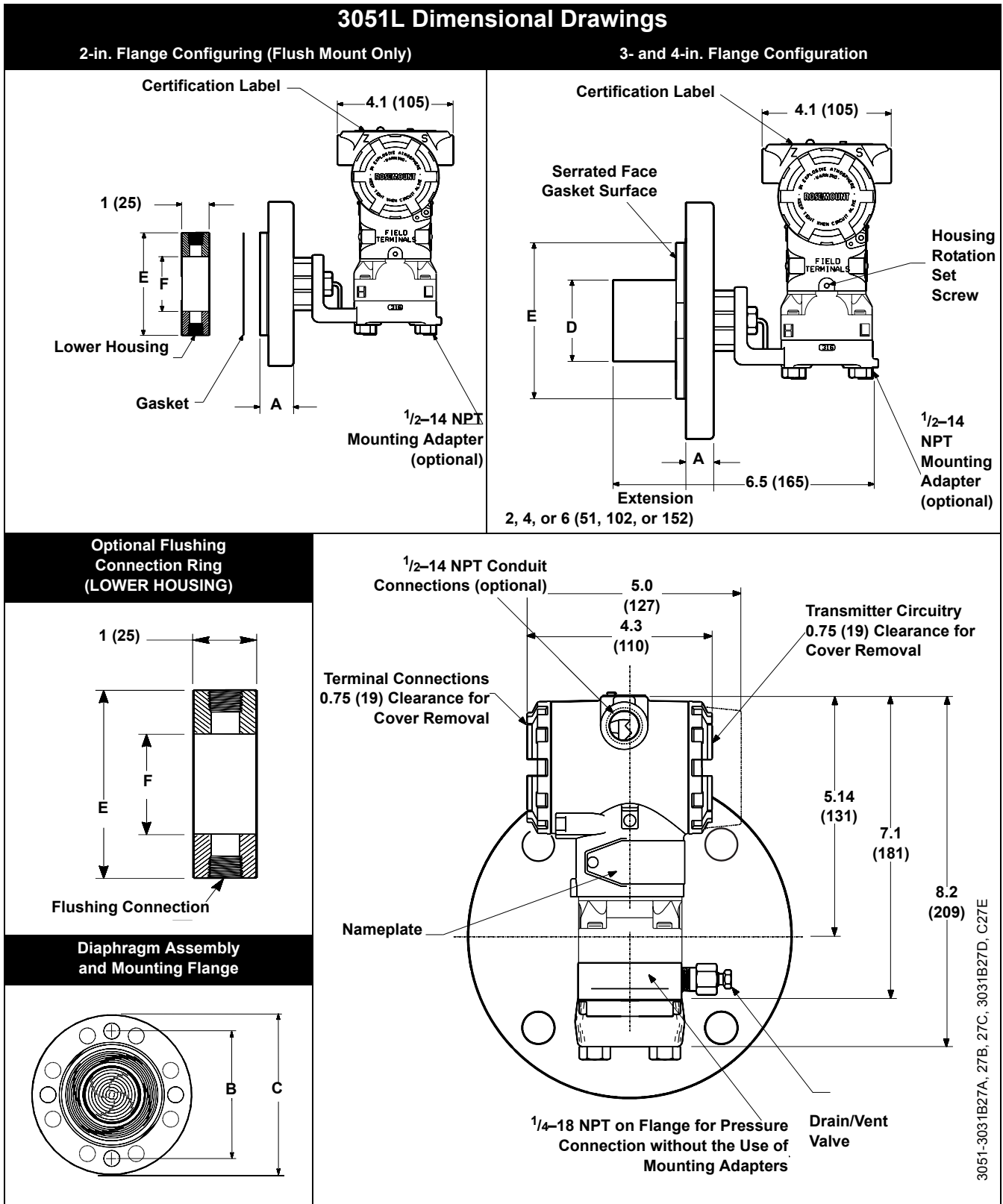

Product Data Sheet

00813-0100-4001, Rev FA

August 2004

Rosemount 3051

TABLE 10. 3051L Dimensional Specifications

Except where indicated, dimensions are in inches (millimeters).

Class	Pipe Size	Flange Thickness	Bolt Circle Diameter	Outside Diameter	No. of Bolts	Bolt Hole Diameter	Exten. Diam. ⁽¹⁾ D	O.D. Gask. Surf. E	Proc. Side F
ASME B 16.5 (ANSI) 150	2 (51)	1.12 (28)	4.75 (121)	6.0 (152)	4	0.75 (19)	NA	3.6 (92)	2.12 (54)
	3 (76)	1.31 (33)	6.0 (152)	7.5 (191)	4	0.75 (19)	2.58 (66)	5.0 (127)	3.5 (89)
	4 (102)	1.31 (33)	7.5 (191)	9.0 (229)	8	0.75 (19)	3.5 (89)	6.2 (158)	4.5 (114)
ASME B 16.5 (ANSI) 300	2 (51)	1.25 (32)	5.0 (127)	6.5 (165)	8	0.75 (19)	NA	3.6 (92)	2.12 (54)
	3 (76)	1.50 (38)	6.62 (168)	8.25 (210)	8	0.88 (22)	2.58 (66)	5.0 (127)	3.5 (89)
	4 (102)	1.62 (41)	7.88 (200)	10.0 (254)	8	0.88 (22)	3.5 (89)	6.2 (158)	4.5 (114)
ASME B 16.5 (ANSI) 600	2 (51)	1.12 (28)	5.0 (127)	6.5 (165)	8	0.75 (19)	NA	3.6 (92)	2.12 (54)
	3 (76)	1.37 (35)	6.62 (168)	6.62 (168)	8	0.88 (22)	2.58 (66)	5.0 (127)	3.5 (89)
DIN PN 10–40	DN 50	26 mm	125 mm	165 mm	4	18 mm	NA	4.0 (102)	2.5 (63)
DIN PN 25/40	DN 80	30 mm	160 mm	200 mm	8	18 mm	65 mm	5.4 (138)	3.7 (94)
	DN 100	30 mm	190 mm	235 mm	8	22 mm	89 mm	6.2 (158)	4.5 (114)
DIN PN 10/16	DN 100	26 mm	180 mm	220 mm	8	18 mm	89 mm	6.2 (158)	4.5 (114)

(1) Tolerances are 0.040 (1,02), -0.020 (0,51)

Ordering Information

TABLE 11. 3051C Differential, Gage, and Absolute Pressure Transmitters — = Not Applicable • = Applicable

Model	Transmitter Type (Select One)			CD	CG	CA
3051CD	Differential Pressure Transmitter			•	—	—
3051CG	Gage Pressure Transmitter			—	•	—
3051CA	Absolute Pressure Transmitter			—	—	•
	3051CD	3051CG ⁽¹⁾	3051CA	CD	CG	CA
0 ⁽²⁾	-3 to 3 inH ₂ O/0.1 inH ₂ O (-7,5 to 7,5 mbar/0,25 mbar)	Not Applicable	Not Applicable	•	—	•
1	-25 to 25 inH ₂ O/0.5 inH ₂ O (-62,2 to 62,2 mbar/1,2 mbar)	-25 to 25 inH ₂ O/0.5 inH ₂ O (-62,2 to 62,2 mbar/1,2 mbar)	0 to 30 psia/0.3 psia (0 to 2,1 bar/20,7 mbar)	•	•	•
2	-250 to 250 inH ₂ O/2.5 inH ₂ O (-623 to 623 mbar/6,2 mbar)	-250 to 250 inH ₂ O/2.5 inH ₂ O (-623 to 623 mbar/6,2 mbar)	0 to 150 psia/1.5 psia (0 to 10,3 bar/0,1 bar)	•	•	•
3	-1000 to 1000 inH ₂ O/10 inH ₂ O (-2,5 to 2,5 bar/25 mbar)	-407 to 1000 inH ₂ O/10 inH ₂ O (-1,01 to 2,5 bar/25 mbar)	0 to 800 psia/8 psia (0 to 55,2 bar/0,55 bar)	•	•	•
4	-300 to 300 psi/3 psi (-20,7 to 20,7 bar/0,2 bar)	-14.7 to 300 psi/3 psi (-1,01 to 20,7 bar/0,2 bar)	0 to 4000 psia/40 psia (0 to 275,8 bar/2,8 bar)	•	•	•
5	-2000 to 2000 psi/20 psi (-137,9 to 137,9 bar/1,4 bar)	-14.7 to 2000 psig/20 psi (-1,01 to 137,9 bar/1,4 bar)	Not Applicable	•	•	—
Code	Output			CD	CG	CA
A	4–20 mA with Digital Signal Based on HART Protocol			•	•	•
M ⁽³⁾	Low-Power, 1–5 V dc with Digital Signal Based on HART Protocol (See Option C2 for 0.8–3.2 V dc)			•	•	•
F	FOUNDATION fieldbus			•	•	•
W	Profibus — PA			•	•	•
Code	Materials of Construction			CD	CG	CA
	Process Flange Type	Flange Material	Drain/Vent			
2	Coplanar	SST	SST	•	•	•
3 ⁽⁴⁾	Coplanar	Alloy C	Hastelloy C276	•	•	•
4	Coplanar	Monel	Monel	•	•	•
5	Coplanar	Plated CS	SST	•	•	•
7 ⁽⁴⁾	Coplanar	SST	Hastelloy C276	•	•	•
8 ⁽⁴⁾	Coplanar	Plated CS	Hastelloy C276	•	•	•
0	Alternate Flange—See Options on page 25			•	•	•
Code	Isolating Diaphragm			CD	CG	CA
2 ⁽⁴⁾	316L SST			•	•	•
3 ⁽⁴⁾	Hastelloy C276			•	•	•
4	Monel			•	•	•
5	Tantalum (Available on 3051CD and CG, Ranges 2–5 only. Not available on 3051CA)			•	•	—
6	Gold-plated Monel (Use in combination with O-ring Option Code B.)			•	•	•
7	Gold-plated SST			•	•	•
Code	O-ring					
A	Glass-filled PTFE			•	•	•
B	Graphite-filled PTFE			•	•	•
Code	Fill Fluid			CD	CG	CA
1	Silicone			•	•	•
2	Inert fill (Halocarbon)			•	•	—

Product Data Sheet

00813-0100-4001, Rev FA
August 2004

Rosemount 3051

TABLE 11. 3051C Differential, Gage, and Absolute Pressure Transmitters — = Not Applicable • = Applicable

Code	Housing Material	Conduit Entry Size	CD	CG	CA
A	Polyurethane-covered Aluminum	½–14 NPT	•	•	•
B	Polyurethane-covered Aluminum	M20 × 1.5 (CM20)	•	•	•
C	Polyurethane-covered Aluminum	PG 13.5	•	•	•
D	Polyurethane-covered Aluminum	G½	•	•	•
J	SST	½–14 NPT	•	•	•
K	SST	M20 × 1.5 (CM20)	•	•	•
L	SST	PG 13.5	•	•	•
M	SST	G½	•	•	•
Code	PlantWeb Functionality		CD	CG	CA
A01	Regulatory control suite: PID, arith, signal char, integ, etc.; requires FOUNDATION fieldbus		•	•	•
D01	Diagnostics suite, Plugged Impulse Line and SPM diagnostics; requires FOUNDATION fieldbus		•	•	•
Code	Alternate Flange Options (Requires Materials of Construction Code 0)		CD	CG	CA
H2	Traditional Flange, 316 SST, SST Drain/Vent		•	•	•
H3 ⁽⁴⁾	Traditional Flange, Alloy C, Hastelloy C276 Drain/Vent		•	•	•
H4	Traditional Flange, Monel, Monel Drain/Vent		•	•	•
H7 ⁽⁴⁾	Traditional Flange, 316 SST, Hastelloy C276 Drain/Vent		•	•	•
HJ	DIN Compliant Traditional Flange, SST, 7/16 in. Adapter/Manifold Bolting		•	•	•
HK	DIN Compliant Traditional Flange, SST, 10 mm Adapter/Manifold Bolting		•	•	•
HL	DIN Compliant Traditional Flange, SST, 12mm Adapter/Manifold Bolting (Not available on 3051CD0)		•	•	•
FA	Level Flange, SST, 2 in., ANSI Class 150, Vertical Mount		•	•	•
FB	Level Flange, SST, 2 in., ANSI Class 300, Vertical Mount		•	•	•
FC	Level Flange, SST, 3 in., ANSI Class 150, Vertical Mount		•	•	•
FD	Level Flange, SST, 3 in., ANSI Class 300, Vertical Mount		•	•	•
FP	DIN Level Flange, SST, DN 50, PN 40, Vertical Mount		•	•	•
FQ	DIN Level Flange, SST, DN 80, PN 40, Vertical Mount		•	•	•
Code	Integral Mount Manifold Options (Requires Materials of Construction Code 0)		CD	CG	CA
S5	Assemble to Rosemount 305 Integral Manifold (specified separately, see the Rosemount 305 and 306 Integral Manifolds PDS (document number 00813-0100-4733))		•	•	•
Code	Integral Mount Primary Elements (Optional)		CD	CG	CA
S4	Factory Assembly to Rosemount Primary Element (Annubar or Rosemount 1195 Integral Orifice) (With the primary element installed, the maximum operating pressure will equal the lesser of either the transmitter or the primary element. Option is available for factory assembly to range 1–4 transmitters only)		•	—	—
S3	Factory Assembly to Rosemount 405 Primary Element		•	—	—
Diaphragm Seal Assemblies (Optional)					
Code	NOTE: Standard flange and adapter bolts are austenitic 316 SST.		CD	CG	CA
S1	One Diaphragm Seal (Direct Mount or Capillary Connection Type)		•	•	•
S2	Two Diaphragm Seals (Direct Mount or Capillary Connection Type)		•	—	—
Optional All Welded Diaphragm Seal Systems (for high vacuum applications)					
Code	NOTE: Standard flange and adapter bolts are austenitic 316 SST.		CD	CG	CA
S7	One Diaphragm Seal, All-Welded System (Capillary Connection Type)		•	•	•
S8	Two Diaphragm Seals, All-Welded System (Capillary Connection Type)		•	—	—
S0	One Diaphragm Seal, All-Welded System (Direct Mount Connection Type)		•	•	•
S9	Two Diaphragm Seals, All-Welded System (One Direct Mount and One Capillary Connection Type)		•	—	—

Rosemount 3051

TABLE 11. 3051C Differential, Gage, and Absolute Pressure Transmitters — = Not Applicable • = Applicable

Code	Mounting Bracket Options	CD	CG	CA
B4	Coplanar Flange Bracket for 2-in. Pipe or Panel Mounting, all SST	•	•	•
B1	Traditional Flange Bracket for 2-in. Pipe Mounting, CS Bolts	•	•	•
B2	Traditional Flange Bracket for Panel Mounting, CS Bolts	•	•	•
B3	Traditional Flange Flat Bracket for 2-in. Pipe Mounting, CS Bolts	•	•	•
B7	B1 Bracket with Series 300 SST Bolts	•	•	•
B8	B2 Bracket with Series 300 SST Bolts	•	•	•
B9	B3 Bracket with Series 300 SST Bolts	•	•	•
BA	SST B1 Bracket with Series 300 SST Bolts	•	•	•
BC	SST B3 Bracket with Series 300 SST Bolts	•	•	•
Code	Hazardous Locations Certification Options	CD	CG	CA
E5	FM Explosionproof Approval	•	•	•
I5	FM Non-incendive and Intrinsic Safety Approval	•	•	•
K5	FM Explosionproof and Intrinsic Safety Approval	•	•	•
I1 ⁽⁵⁾	ATEX Intrinsic Safety and Dust Certification	•	•	•
N1 ⁽⁵⁾	ATEX Type N and Dust Certification	•	•	•
E8	ATEX Flame-proof and Dust Certification	•	•	•
E4 ⁽⁵⁾	JIS Flame-proof Certification	•	•	•
I4	JIS Intrinsic Safety Certification (<i>Only available with HART Option Code A</i>)	•	•	—
C5 ⁽⁶⁾	Measurement Canada Accuracy Approval (<i>Limited availability depending on transmitter type and range. Contact an Emerson Process Management representative</i>)	•	•	•
C6	CSA Explosion-proof and Intrinsic Safety Approval	•	•	•
K6 ⁽⁵⁾	CSA and ATEX Explosion-proof and Intrinsic Safety Approval (combination of C6 and K8)	•	•	•
KB	FM and CSA Explosion-proof and Intrinsic Safety Approvals (combination of K5 and C6)	•	•	•
K7	SAA Flame-proof and Intrinsic Safety Approvals (combination of I7, N7, and E7)	•	•	•
K8 ⁽⁵⁾	ATEX Flame-proof and Intrinsic Safety Approvals (combination of I1 and E8)	•	•	•
KD ⁽⁵⁾	CSA, FM, and ATEX Explosion-proof and Intrinsic Safety Approval (combination of K5, C6, I1, and E8)	•	•	•
I7	SAA Intrinsic Safety Certification	•	•	•
E7	SAA Flame-proof Certification	•	•	•
N7	SAA Type N Certification	•	•	•
IA	ATEX Intrinsic Safety for FISCO; for <i>FOUNDATION</i> fieldbus protocol only	•	•	•
Code	Bolting Options	CD	CG	CA
L4	Austenitic 316 SST Bolts	•	•	•
L5	ASTM A 193, Grade B7M Bolts	•	•	•
L6	Monel Bolts	•	•	•
Code	Meters (Optional)	CD	CG	CA
M5	LCD display for Aluminum Housing (Housing Codes A, B, C, and D only)	•	•	•
M6	LCD display for SST Housing (Housing Codes J, K, L, and M only)	•	•	•

TABLE 11. 3051C Differential, Gage, and Absolute Pressure Transmitters — = Not Applicable • = Applicable

Code	Other Options	CD	CG	CA
Q4	Calibration Data Sheet	•	•	•
Q8	Material Traceability Certification per EN 10204 3.1.B (Only available for the sensor module housing and Coplanar or traditional flanges and adapters (3051C), and for the sensor module housing and low-volume Coplanar flange and adapter (3051C with Option Code S1))	•	•	•
Q16	Surface finish certification for sanitary remote seals	•	•	•
QP	Calibration certification and tamper evident seal	•	•	•
QS	Quality Certification for safety	•	•	•
J1 ⁽⁶⁾⁽⁷⁾	Local Zero Adjustment Only	•	•	•
J3 ⁽⁶⁾⁽⁷⁾	No Local Zero or Span Adjustment	•	•	•
T1	Transient Protection Terminal Block	•	•	•
C1 ⁽⁶⁾	Custom Software Configuration (Completed CDS 00806-0100-4001 required with order)	•	•	•
C2 ⁽⁶⁾	0.8–3.2 V dc Output with Digital Signal Based on HART Protocol (Output Code M only)	•	•	•
C3	Gage Calibration (3051CA4 only)	—	—	•
C4 ⁽⁶⁾⁽⁸⁾	Analog Output Levels Compliant with NAMUR Recommendation NE 43	•	•	•
CN ⁽⁶⁾⁽⁸⁾	Analog Output Levels Compliant with NAMUR Recommendation NE 43 Alarm Configuration—Low	•	•	•
P1	Hydrostatic Testing	•	•	•
P2	Cleaning for Special Service	•	•	•
P3	Cleaning for <1 PPM Chlorine/Fluorine	•	•	•
P4	Calibrate at line pressure (Specify Q48 on order for corresponding certificate)	•	•	•
DF	1/2 -14 NPT flange adapter(s)— Material determined by flange material	•	•	•
D7	Coplanar Flange Without Drain/Vent Ports	•	•	•
D8	Ceramic Ball Drain/Vents	•	•	•
D9	JIS Process Connection—RC 1/4 Flange with RC 1/2 Flange Adapter	•	•	•
P8	0.04% accuracy to 5:1 turndown (Range 2-4)	•	•	•
P9	4500 psig Static Pressure Limit (3051CD Ranges 2–5 only)	•	—	—
V5 ⁽⁹⁾	External Ground Screw Assembly	•	•	•
Typical Model Number: 3051CD 2 A 2 2 A 1 A B4				

- (1) 3051CG lower range limit varies with atmospheric pressure.
- (2) 3051CD0 is available only with Output Code A, Process Flange Code 0 (Alternate Flange H2, H7, HJ, or HK), Isolating Diaphragm Code 2, O-ring Code A, and Bolting Option L4.
- (3) Not available with hazardous locations certification Options Codes I1, N1, E4, K6 and K8.
- (4) Materials of Construction comply with recommendations per NACE MR0175/ISO 15156 for sour oil field production environments. Environmental limits apply to certain materials. Consult latest standard for details. Selected materials also conform to NACE MR0103 for sour refining environments.
- (5) Not available with Low Power code M.
- (6) Not available with Fieldbus (output code F) or Profibus (output code W).
- (7) Local zero and span adjustments are standard unless Option Code J1 or J3 is specified
- (8) NAMUR-Compliant operation is pre-set at the factory and cannot be changed to standard operation in the field.
- (9) The V5 option is not needed with the T1 option; external ground screw assembly is included with the T1 option.

Rosemount 3051

TABLE 12. 3051T Gage and Absolute Pressure Transmitter

Model	Transmitter Type	
3051T	Pressure Transmitter	
Code	Pressure Type	
G	Gage	
A	Absolute	
Code	Pressure Ranges (Range/Min. Span)	
	3051TG ⁽¹⁾	3051TA
1	-14.7 to 30 psi/0.3 psi (-1,01 to 2,1 bar/20,7 mbar)	0 to 30 psia/0.3 psia (0 to 2,1 bar/20,7 mbar)
2	-14.7 to 150 psi/1.5 psi (-1,01 to 10,3 bar/103,4 mbar)	0 to 150 psia/1.5 psia (0 to 10,3 bar/103,4 mbar)
3	-14.7 to 800 psi/8 psi (-1,01 to 55,2 bar/0,55 bar)	0 to 800 psia/8 psia (0 to 55,2 bar/0,55 bar)
4	-14.7 to 4000 psi/40 psi (-1,01 to 275,8 bar/2,8 bar)	0 to 4000 psia/40 psia (0 to 275,8 bar/2,8 bar)
5	-14.7 to 10000 psi/2000 psi (-1,01 to 689,5 bar/138 bar)	0 to 10000 psia/2000 psia (0 to 689,5 bar/138 bar)
Code	Output	
A	4–20 mA with Digital Signal Based on <i>HART</i> Protocol	
M	Low-Power 1–5 V dc with Digital Signal Based on <i>HART</i> Protocol (See Option Code C2 for 0.8–3.2 V dc Output) (Not available with hazardous certification Option Codes I1, N1, E4, K6 or K8)	
F	<i>FOUNDATION</i> fieldbus	
W	Profibus — PA	
Code	Process Connection Style	
2B	1/2–14 NPT Female	
2C	G1/2 A DIN 16288 Male (Available in SST for Range 1–4 only)	
2F	Coned and Threaded, Compatible with Autoclave Type F-250-C (Only available in SST for Range 5)	
Code	Isolating Diaphragm	Process Connection Wetted Parts Material
2 ⁽²⁾	316L SST	316L SST
3 ⁽²⁾	<i>Hastelloy</i> C276	<i>Hastelloy</i> C276
Code	Fill Fluid	
1	Silicone	
2	Inert (Fluorinert [®] FC-43)	
Code	Housing Material	Conduit Entry Size
A	Polyurethane-covered Aluminum	1/2–14 NPT
B	Polyurethane-covered Aluminum	M20 × 1.5 (CM20)
C	Polyurethane-covered Aluminum	PG 13.5
D	Polyurethane-covered Aluminum	G1/2
J	SST	1/2–14 NPT
K	SST	M20 × 1.5 (CM20)
L	SST	PG 13.5
M	SST	G1/2
Code	PlantWeb Functionality	
A01	Regulatory control suite: PID, arith, signal char, integ, etc.; requires <i>FOUNDATION</i> fieldbus	
D01	Diagnostics suite, Plugged Impulse Line and SPM diagnostics; requires <i>FOUNDATION</i> fieldbus	
Code	Integral Mount Manifold (Optional)	
S5	Assemble to Rosemount 306 Integral Manifold (specified separately, see the Rosemount 305 and 306 Integral Manifolds PDS (document number 00813-0100-4733)) (Requires 1/2-in. process connection code 2B)	
Code	Remote Diaphragm Seals Assemblies (Optional)	
S1	One remote diaphragm seal (Direct Mount or Capillary Connection Type) (Requires Process Connection Style code 2B)	
Code	Mounting Brackets (Optional)	
B4	Bracket for 2-in. Pipe or Panel Mounting, All SST	

Product Data Sheet

00813-0100-4001, Rev FA
August 2004

Rosemount 3051

TABLE 12. 3051T Gage and Absolute Pressure Transmitter

Code	Hazardous Locations Certifications (Optional)
E5	FM Explosion-proof Approval
I5	FM Non-incendive and Intrinsic Safety Approval
K5	FM Explosion-proof and Intrinsic Safety Approval
C5	Measurement Canada accuracy approval (<i>Limited availability depending on transmitter type and range. Contact an Emerson Process Management representative</i>)
C6	CSA Explosion-proof and Intrinsic Safety Approval
K6 ⁽³⁾	CSA and ATEX Explosion-proof and Intrinsic Safety Approval (combination of C6 and K8)
KB	FM and CSA Explosion-proof and Intrinsic Safety Approvals (combination of K5 and C6)
K7	SAA Flame-proof and Intrinsic Safety Approvals (combination of I7, N7, and E7)
K8 ⁽³⁾	ATEX Flame-proof and Intrinsic Safety Approvals (combination of I1 and E8)
KD ⁽³⁾	CSA, FM, and ATEX Explosion-proof and Intrinsic Safety Approval (combination of K5, C6, I1, and E8)
I7	SAA Intrinsic Safety Certification
E4 ⁽³⁾	JIS Flame-proof Certification
E7	SAA Flame-proof Certification
N7	SAA Type N Certification
I1 ⁽³⁾	ATEX Intrinsic Safety and Dust Certification
N1 ⁽³⁾	ATEX Type N and Dust Certification
E8	ATEX Flame-proof and Dust Certification
DW	NSF drinking water approval
IA	ATEX Intrinsic Safety for FISCO; for FOUNDATION fieldbus protocol only
Code	Other Options
Q4	Calibration Data Sheet
Q8	Material Traceability Certification per EN 10204 3.1.B <i>NOTE: This option applies to the process connection only.</i>
Q16	Surface finish certification for sanitary remote seals
QP	Calibration certification and tamper evident seal
QS	Quality certification for safety
J1 ⁽⁴⁾⁽⁵⁾	Local Zero Adjustment Only
J3 ⁽⁴⁾⁽⁵⁾	No Local Zero or Span Adjustment
M5	LCD display for Aluminum Housing (Housing Codes A, B, C, and D only)
M6	LCD display for SST Housing (Housing Codes J, K, L and M only)
T1	Transient Protection Terminal Block
C1 ⁽⁴⁾	Custom Software Configuration (Completed CDS 00806-0100-4001 required with order)
C2 ⁽⁴⁾	0.8–3.2 V dc Output with Digital Signal Based on HART Protocol (Output Code M only)
C4 ⁽⁴⁾⁽⁶⁾	Analog Output Levels Compliant with NAMUR Recommendation NE 43, 27-June-1996.
CN ⁽⁴⁾⁽⁶⁾	Analog Output Levels Compliant with NAMUR Recommendation NE 43: Low Alarm Configuration
P1	Hydrostatic Testing
P2	Cleaning for Special Service
P3	Cleaning for <1 PPM Chlorine/Fluorine
P8	0.04% accuracy to 5:1 turndown (Range 1-4)
V5 ⁽⁷⁾	External Ground Screw Assembly
Typical Model Number: 3051T G 5 F 2A 2 1 A B4	

(1) 3051TG lower range limit varies with atmospheric pressure.

(2) Materials of Construction comply with recommendations per NACE MR0175/ISO 15156 for sour oil field production environments. Environmental limits apply to certain materials. Consult latest standard for details. Selected materials also conform to NACE MR0103 for sour refining environments.

(3) Not available with low-power Option Code M.

(4) Not available with fieldbus (output code F) or Profibus protocols (output code W).

(5) Local zero and span adjustments are standard unless Option Code J1 or J3 is specified.

(6) NAMUR-Compliant operation is pre-set at the factory and cannot be changed to standard operation in the field.

(7) The V5 option is not needed with T1 option; external ground screw assembly is included with the T1 option.

Rosemount 3051

TABLE 13. 3051L Flange-Mounted Liquid Level Transmitter

Model	Transmitter Type		
3051L	Flange-Mounted Liquid Level Transmitter		
Code	Pressure Ranges (Range/Min. Span)		
2	–250 to 250 inH ₂ O/2.5 inH ₂ O (–0,6 to 0,6 bar/6,2 mbar)		
3	–1000 to 1000 inH ₂ O/10 inH ₂ O (–2,5 to 2,5 bar/25 mbar)		
4	–300 to 300 psi/3 psi (–20,7 to 20,7 bar/0,2 bar)		
Code	Output		
A	4–20 mA with Digital Signal Based on <i>HART</i> Protocol		
M	Low-Power 1–5 V dc with Digital Signal Based on <i>HART</i> Protocol (See Option Code C2 for 0.8–3.2 V dc Output) (Not available with hazardous certification Option Codes I1, N1, E4, K6, and K8)		
F	<i>FOUNDATION</i> fieldbus		
W	Profibus – PA		
High Pressure Side			
Code	Diaphragm Size	Material	Extension Length
G0	2 in./DN 50	316L SST	Flush Mount Only
H0	2 in./DN 50	<i>Hastelloy</i> C276	Flush Mount Only
J0	2 in./DN 50	Tantalum	Flush Mount Only
A0	3 in./DN 80	316L SST	Flush Mount
A2	3 in./DN 80	316L SST	2 in./50 mm
A4	3 in./DN 80	316L SST	4 in./100 mm
A6	3 in./DN 80	316L SST	6 in./150 mm
B0	4 in./DN 100	316L SST	Flush Mount
B2	4 in./DN 100	316L SST	2 in./50 mm
B4	4 in./DN 100	316L SST	4 in./100 mm
B6	4 in./DN 100	316L SST	6 in./150 mm
C0	3 in./DN 80	<i>Hastelloy</i> C276	Flush Mount
C2	3 in./DN 80	<i>Hastelloy</i> C276	2 in./50 mm
C4	3 in./DN 80	<i>Hastelloy</i> C276	4 in./100 mm
C6	3 in./DN 80	<i>Hastelloy</i> C276	6 in./150 mm
D0	4 in./DN 100	<i>Hastelloy</i> C276	Flush Mount
D2	4 in./DN 100	<i>Hastelloy</i> C276	2 in./50 mm
D4	4 in./DN 100	<i>Hastelloy</i> C276	4 in./100 mm
D6	4 in./DN 100	<i>Hastelloy</i> C276	6 in./150 mm
E0	3 in./DN 80	Tantalum	Flush Mount Only
F0	4 in./DN 100	Tantalum	Flush Mount Only

Product Data Sheet

00813-0100-4001, Rev FA

August 2004

Rosemount 3051

TABLE 13. 3051L Flange-Mounted Liquid Level Transmitter

Mounting Flange			
Code	Size	ASME B 16.5 (ANSI) or DIN Flange Rating	Material
M	2 in.	Class 150	CS
A	3 in.	Class 150	CS
B	4 in.	Class 150	CS
N	2 in.	Class 300	CS
C	3 in.	Class 300	CS
D	4 in.	Class 300	CS
P	2 in.	Class 600	CS
E	3 in.	Class 600	CS
X	2 in.	Class 150	SST
F	3 in.	Class 150	SST
G	4 in.	Class 150	SST
Y	2 in.	Class 300	SST
H	3 in.	Class 300	SST
J	4 in.	Class 300	SST
Z	2 in.	Class 600	SST
L	3 in.	Class 600	SST
Q	DN 50	PN 10-40	CS
R	DN 80	PN 40	CS
S	DN 100	PN 40	CS
V	DN 100	PN 10/16	CS
K	DN 50	PN 10-40	SST
T	DN 80	PN 40	SST
U	DN 100	PN 40	SST
W	DN 100	PN 10/16	SST

Code	Process Fill-High Pressure Side	Temperature Limits
A	<i>Syltherm XLT</i>	-100 to 300 °F (-73 to 135 °C)
C	<i>D. C. Silicone 704</i>	60 to 400 °F (15 to 205 °C)
D	<i>D. C. Silicone 200</i>	-40 to 400 °F (-40 to 205 °C)
H	Inert (Halocarbon)	-50 to 350 °F (-45 to 177 °C)
G	Glycerine and Water	0 to 200 °F (-17 to 93 °C)
N	<i>Neobee M-20</i>	0 to 400 °F (-17 to 205 °C)
P	Propylene Glycol and Water	0 to 200 °F (-17 to 93 °C)

Low Pressure Side				
Code	Configuration	Flange Adapter	Diaphragm Material	Sensor Fill Fluid
11	Gage	SST	316L SST	Silicone
21	Differential	SST	316L SST	Silicone
22	Differential	SST	<i>Hastelloy C276</i>	Silicone
2A	Differential	SST	316L SST	Inert (Halocarbon)
2B	Differential	SST	<i>Hastelloy C276</i>	Inert (Halocarbon)
31	Remote Seal	SST	316L SST	Silicone (<i>Requires Option Code S1</i>)

Code	O-ring Material
A	Glass-filled PTFE

Rosemount 3051

TABLE 13. 3051L Flange-Mounted Liquid Level Transmitter

Code	Housing Material	Conduit Entry Size
A	Polyurethane-covered Aluminum	½–14 NPT
B	Polyurethane-covered Aluminum	M20 × 1.5 (CM20)
C	Polyurethane-covered Aluminum	PG 13.5
D	Polyurethane-covered Aluminum	G½
J	SST	½–14 NPT
K	SST	M20 × 1.5 (CM20)
L	SST	PG 13.5
M	SST	G½
Code	<i>PlantWeb</i> Functionality	
A01	Regulatory control suite: PID, arith, signal char, integ, etc. (<i>requires Foundation fieldbus</i>)	
D01	Diagnostics suite, Plugged Impulse Line and SPM diagnostics (<i>requires Foundation fieldbus</i>)	
Code	Diaphragm Seal Assemblies (Optional)	
S1	One Diaphragm Seal (<i>requires low pressure side Option Code 31 capillary connection type</i>)	
Code	Hazardous Locations Certification Options	
E5	FM Explosion-proof Approval	
I5	FM Non-incendive and Intrinsic Safety Approval	
K5	FM Explosion-proof and Intrinsic Safety Approval	
I1 ⁽¹⁾	ATEX Intrinsic Safety and Dust Certification	
N1 ⁽¹⁾	ATEX Type N and Dust Certification	
E8	ATEX Flame-proof and Dust Certification	
E4 ⁽¹⁾	JIS Flame-proof Certification	
C6	CSA Explosion-proof and Intrinsic Safety Approval	
K6 ⁽¹⁾	CSA and ATEX Explosion-proof and Intrinsic Safety Approval (combination of C6 and K8)	
KB	FM and CSA Explosion-proof and Intrinsic Safety Approvals (combination of K5 and C6)	
K7	SAA Flame-proof and Intrinsic Safety Approvals (combination of I7, N7, and E7)	
K8 ⁽¹⁾	ATEX Flame-proof and Intrinsic Safety Approvals (combination of I1 and E8)	
KD ⁽¹⁾	CSA, FM, and ATEX Explosion-proof and Intrinsic Safety Approval (combination of K5, C6, I1, and E8)	
I7	SAA Intrinsic Safety Certification	
E7	SAA Flame-proof Certification	
N7	SAA Type N Certification	
IA	ATEX Intrinsic Safety for FISCO; for <i>FOUNDATION</i> fieldbus protocol only	
Code	Bolt for Flange and Adapters (Optional)	
L5	ASTM A 193, Grade B7M Bolts	
Code	Meter Options	
M5	LCD display for Aluminum Housing (<i>Available with Housing codes A, B, C, and D only</i>)	
M6	LCD display for SST Housing (<i>Available with Housing codes J, K, L, and M only</i>)	

Product Data Sheet

00813-0100-4001, Rev FA
August 2004

Rosemount 3051

TABLE 13. 3051L Flange-Mounted Liquid Level Transmitter

Code		Other Options				
Q4	Calibration Data Sheet					
Q8	Material Traceability Certification per EN 10204 3.1.B (Available with the diaphragm, upper housing, Coplanar flange, adapter, sensor module housing, lower housing/flushing connection, and extension)					
QP	Calibration certification and tamper evident seal					
J1 ⁽²⁾⁽³⁾	Local Zero Adjustment Only					
J3 ⁽²⁾⁽³⁾	No Local Zero or Span Adjustment					
T1	Transient Protection Terminal Block					
C1 ⁽²⁾	Custom Software Configuration (Completed CDS 00806-0100-4001 required with order)					
C2 ⁽²⁾	0.8–3.2 V dc Output with Digital Signal Based on HART Protocol (Available with Output code M only)					
C4 ⁽²⁾⁽⁴⁾	Analog Output Levels Compliant with NAMUR Recommendation NE 43					
CN ⁽²⁾⁽⁴⁾	Analog Output Levels Compliant with NAMUR Recommendation NE 43: Alarm Configuration–Low					
D8	Ceramic Ball Drain/Vents					
V5 ⁽⁵⁾	External Ground Screw Assembly					
Code		Lower Housing Flushing Connections				
	Ring Material	Number	Size	2 in.	3 in.	4 in.
F1	SST	1	1/4	•	•	•
F2	SST	2	1/4	•	•	•
F3 ⁽⁶⁾	Hastelloy C276	1	1/4	•	•	•
F4 ⁽⁶⁾	Hastelloy C276	2	1/4	•	•	•
F7	SST	1	1/2	•	•	•
F8	SST	2	1/2	•	•	•
F9	Hastelloy C276	1	1/2	•	•	•
F0	Hastelloy C276	2	1/2	•	•	•
Typical Model Number:						

- (1) Not available with low-power Option Code M
- (2) Not available with fieldbus (output code F) or profibus protocols (output code W).
- (3) Local zero and span adjustments are standard unless Option Code J1 or J3 is specified.
- (4) NAMUR-Compliant operation is pre-set at the factory and cannot be changed to standard operation in the field.
- (5) The V5 option is not needed with the T1 option; external ground screw assembly is included with the T1 option.
- (6) Not available with Option Codes A0, B0, and G0.

Rosemount 3051

TABLE 14. 3051H Pressure Transmitter for High-Temperature Processes — = Not Applicable • = Applicable

Model	Transmitter Type (Select One)	HD	HG	
3051HD	Differential Pressure Transmitter for High-Temperature Processes	•	—	
3051HG	Gage Pressure Transmitter for High-Temperature Processes	—	•	
Code	3051HD	3051HG		
2	–250 to 250 inH ₂ O/2.5 inH ₂ O (–0,62 to 0,62 bar/6,2 mbar)	–250 to 250 inH ₂ O/2.5 inH ₂ O (–0,62 to 0,62 bar/6,2 mbar)		
3	–1000 to 1000 inH ₂ O/10 inH ₂ O (–2,5 to 2,5 bar/25 mbar)	–407 to 1000 inH ₂ O/10 in H ₂ O (–1,01 to 2,5 bar/25 mbar)		
4	–300 to 300 inH ₂ O/3 psi (–747 to 747 mbar/0,2 bar)	–14.7 to 300 psi/3 psi (–1,01 to 20,7 bar/0,2 bar)		
5	–2000 to 2000 psi/20 psi (–138 to 138 bar/1,4 bar)	–14.7 to 2000 psig/20 psi (–1,01 to 138 bar/1,4 bar)		
<i>NOTE: 3051HG lower range limit varies with atmospheric pressure.</i>				
Code	Output	HD	HG	
A	4–20 mA with Digital Signal Based on HART Protocol	•	•	
M	Low-Power 1–5 V dc with Digital Signal Based on HART Protocol (See Option Code C2 for 0.8–3.2 V dc Output) (Not available with hazardous certification Option Codes I1, N1, E4, K6, and K8)	•	•	
F	FOUNDATION fieldbus	•	•	
W	Profibus – PA	•	•	
Code	Process Connection	HD	HG	
	Process Flange Material Drain/Vent			
2	SST SST	•	•	
7 ⁽¹⁾	SST Hastelloy C276	•	•	
Code	Process Isolating Diaphragm	HD	HG	
2	316L SST	•	•	
3 ⁽¹⁾	Hastelloy C276	•	•	
5	Tantalum	•	•	
Code	O-ring Material	HD	HG	
A	Glass-Filled PTFE	•	•	
Code	Process Fill Fluid	HD	HG	
D	D.C. 200 Silicone	•	•	
H	Inert	•	•	
N	Neobee M-20	•	•	
Code	Sensor Module Isolator Material	HD	HG	
2	SST	•	•	
Code	Sensor Module Fill Fluid	HD	HG	
1	Silicone	•	•	
2	Inert (Halocarbon)	•	•	
Code	Housing Material	Conduit Entry Size	HD	HG
A	Polyurethane-covered Aluminum	½–14 NPT	•	•
B	Polyurethane-covered Aluminum	M20 × 1.5 (CM20)	•	•
C	Polyurethane-covered Aluminum	PG 13.5	•	•
D	Polyurethane-covered Aluminum	G½	•	•
J	SST	½–14 NPT	•	•
K	SST	M20 × 1.5 (CM20)	•	•
L	SST	PG 13.5	•	•
M	SST	G½	•	•
Code	PlantWeb Functionality			
A01	Regulatory control suite: PID, arith, signal char, integ, etc.; requires FOUNDATION fieldbus			
D01	Diagnostics suite, Plugged Impulse Line and SPM diagnostics; requires FOUNDATION fieldbus			
Code	Integral Mount Primary Elements (Optional)	HD	HG	
S4	Factory Assembly to Rosemount Primary Element (Diamond II+Annubar/Rosemount 1195 Integral Orifice) (With the primary element installed, the maximum operating pressure will equal the lesser of either the transmitter or the primary element. Option is available for factory assembly to range 1–4 transmitters only)	•	—	

Product Data Sheet

00813-0100-4001, Rev FA
August 2004

Rosemount 3051

TABLE 14. 3051H Pressure Transmitter for High-Temperature Processes — = Not Applicable • = Applicable

Code	Mounting Bracket Options	HD	HG
B5	Universal Mounting Bracket for 2-in. Pipe or Panel Mount, CS Bolts	•	•
B6	Universal Mounting Bracket for 2-in. Pipe or Panel Mount, SST Bolts	•	•
Code	Hazardous Locations Certification Options	HD	HG
E5	FM Explosion-proof Approval	•	•
I5	FM Non-incendive and Intrinsic Safety Approval	•	•
K5	FM Explosion-proof and Intrinsic Safety Approval	•	•
I1 ⁽²⁾	ATEX Intrinsic Safety and Dust Certification	•	•
N1 ⁽²⁾	ATEX Type N and Dust Certification	•	•
E8	ATEX Flame-proof and Dust Certification	•	•
E4 ⁽²⁾	JIS Flame-proof Certification	•	•
C6	CSA Explosion-proof and Intrinsic Safety Approval	•	•
K6 ⁽²⁾	CSA and ATEX Explosion-proof and Intrinsic Safety Approval (combination of C6 and K8)	•	•
KB	FM and CSA Explosion-proof and Intrinsic Safety Approvals (combination of K5 and C6)	•	•
K7	SAA Flame-proof and Intrinsic Safety Approvals (combination of I7, N7, and E7)	•	•
KB ⁽²⁾	ATEX Flame-proof and Intrinsic Safety Approvals (combination of I1 and E8)	•	•
KD ⁽²⁾	CSA, FM, and ATEX Explosion-proof and Intrinsic Safety Approval (combination of K5, C6, I1, and E8)	•	•
I7	SAA Intrinsic Safety Certification	•	•
E7	SAA Flame-proof Certification	•	•
N7	SAA Type N Certification	•	•
IA	ATEX Intrinsic Safety for FISCO; for FOUNDATION fieldbus protocol only	•	•
IE	FM FISCO Intrinsic Safety; for FOUNDATION fieldbus protocol only	•	•
Code	Bolt for Flange and Adapter Options	HD	HG
L4	Austenitic 316 SST Bolts	•	•
Code	Meter Options	HD	HG
M5	LCD display for Aluminum Housing (Available with Housing codes A, B, C, and D only)	•	•
M6	LCD display for SST Housing (Available with Housing codes J, K, L, and M only)	•	•
Code	Other Options	HD	HG
Q4	Calibration Data Sheet	•	•
Q8	Material traceability certification per EN 10204 3.1.B	•	•
QP	Calibration certification and tamper evident seal	•	•
J1 ⁽³⁾	Local Zero Adjustment Only (Local zero and span adjustments are standard unless Option Code J1 or J3 is specified.)	•	•
J3 ⁽³⁾	No Local Zero or Span Adjustment (Local zero and span adjustments are standard unless Option Code J1 or J3 is specified)	•	•
T1	Transient Protection Terminal Block	•	•
C1 ⁽³⁾	Custom Software Configuration (Completed CDS 00806-0100-4001 required with order)	•	•
C2 ⁽³⁾	0.8–3.2 V dc Output with Digital Signal Based on HART Protocol (Output Code M only)	•	•
C4 ⁽³⁾⁽⁴⁾	Analog Output Levels Compliant with NAMUR Recommendation NE 43	•	•
CN ⁽³⁾⁽⁴⁾	Analog Output Levels Compliant with NAMUR Recommendation NE 43: Alarm Configuration—Low	•	•
P1	Hydrostatic Testing	•	•
P2	Cleaning for Special Service	•	•
P3	Cleaning for <1 PPM Chlorine/Fluorine	•	•
DF	1/2–14 NPT flange adapters—SST	•	•
D8	Ceramic Ball Drain/Vents	•	•
V5 ⁽⁵⁾	External Ground Screw Assembly	•	•
Typical Model Number: 3051HG 2 A 2 2 A H 2 1 A B5			

- (1) Materials of Construction comply with recommendations per NACE MR0175/ISO 15156 for sour oil field production environments. Environmental limits apply to certain materials. Consult latest standard for details. Selected materials also conform to NACE MR0103 for sour refining environments.
- (2) Not available with low-power Option Code M.
- (3) Not available with fieldbus (output code F) or profibus protocols (output code W).
- (4) NAMUR-Compliant operation is pre-set at the factory and cannot be changed to standard operation in the field.
- (5) The V5 option is not needed with the T1 option; external ground screw assembly is included with the T1 option.

OPTIONS

Standard Configuration

Unless otherwise specified, transmitter is shipped as follows:

ENGINEERING UNITS

Differential/Gage:	inH ₂ O (Range 0, 1, 2, and 3) psi (Range 4 and 5)
Absolute/3051T:	psi (all ranges)
4 mA (1 V dc)⁽¹⁾:	0 (engineering units above)
20 mA (5 V dc):	Upper range limit
Output:	Linear
Flange type:	Specified model code option
Flange material:	Specified model code option
O-ring material:	Specified model code option
Drain/vent:	Specified model code option
Integral meter:	Installed or none
Alarm⁽¹⁾:	Upscale
Software tag:	(Blank)

(1) Not applicable to fieldbus.

Custom Configuration **HART protocol only⁽¹⁾**

If Option Code C1 is ordered, the customer may specify the following data in addition to the standard configuration parameters.

- Output Information
- Transmitter Information
- LCD display Configuration
- Hardware Selectable Information
- Signal Selection

Refer to the "HART Protocol C1 Option Configuration Data Sheet" on page 38.

Tagging (3 options available)

- Standard SST hardware tag is wired to the transmitter. Tag character height is 0.125 in. (3,18 mm), 56 characters maximum.
- Tag may be permanently stamped on transmitter nameplate upon request, 56 characters maximum.
- Tag may be stored in transmitter memory (30 characters maximum). Software tag is left blank unless specified.

Commissioning tag (fieldbus only)

A temporary commissioning tag is attached to all transmitters. The tag indicates the device ID and allows an area for writing the location.

Optional Rosemount 305 or 306 Integral Manifolds

Factory assembled to 3051C and 3051T transmitters. Refer to the following Product Data Sheet (document number 00813-0100-4733) for additional information.

Optional Three-Valve Manifolds (Packaged Separately)

- Part No. 1151-0150-0001: 3-Valve Manifold, Carbon Steel
- Part No. 1151-0150-0002: 3-Valve Manifold, 316 SST

(1) Not applicable to fieldbus.

Optional Diaphragm and Sanitary Seals

Refer to Product Data Sheet 00813-0100-4016 or 00813-0201-4016. for additional information.

Output Information⁽¹⁾

Output range points must be the same unit of measure. Available units of measure include:

inH ₂ O	inH ₂ O@4 °C ⁽¹⁾	psi	Pa
inHg	ftH ₂ O	bar	kPa
mmH ₂ O	mmH ₂ O@4 °C ⁽¹⁾	mbar	torr
mmHg	g/cm ²	kg/cm ²	atm

(1) Not available on low power or previous versions.

LCD display

M5 Digital Meter, 5-Digit, 2-Line LCD

- Direct reading of digital data for higher accuracy
- Displays user-defined flow, level, volume, or pressure units
- Displays diagnostic messages for local troubleshooting
- 90-degree rotation capability for easy viewing

M6 Digital Meter with 316 Stainless Steel Cover

- For use with stainless steel housing option (housing codes J, K, and L)

Local Span and Zero Adjustment⁽²⁾

Transmitters ship with local span and zero adjustments standard unless otherwise specified.

- Non-interactive external zero and span adjustments ease calibration
- Magnetic switches replace standard potentiometer adjustments to optimize performance

J1 Local Zero Adjustment Only⁽¹⁾

J3 No Local Zero or Span Adjustment⁽¹⁾

Transient Protection

T1 Integral Transient Protection Terminal Block

- Integral transient protection terminal block
- Meets IEEE Standard 587, Category B
1 kV crest (10 × 1 000 microseconds)
3 kV crest (8 × 20 microseconds)
6 kV crest (1.2 × 50 microseconds)
- Meets IEEE Standard 472,
Surge Withstand Capability
SWC 2,5 kV crest, 1 MHz wave form
- Applicable standards: IEC 801-4, 801-5

Bolts for Flanges and Adapters

- Options permit bolts for flanges and adapters to be obtained in various materials
- Standard material is plated carbon steel per ASTM A449, Type 1

L4 Austenitic 316 Stainless Steel Bolts

L5 ASTM A 193, Grade B7M Bolts

L6 *Monel* Bolts

(2) Not applicable to fieldbus.

Product Data Sheet

00813-0100-4001, Rev FA
August 2004

Rosemount 3051

Rosemount 3051C Coplanar Flange and 3051T Bracket Option

- B4 Bracket for 2-in. Pipe or Panel Mounting
- For use with the standard *Coplanar* flange configuration
 - Bracket for mounting of transmitter on 2-in. pipe or panel
 - Stainless steel construction with stainless steel bolts

Rosemount 3051H Bracket Options

- B5 Bracket for 2-in. Pipe or Panel Mounting
- For use with the 3051H Pressure Transmitter for high process temperatures
 - Carbon steel construction with carbon steel bolts
- B6 B5 Bracket with SST Bolts
- Same bracket as the B5 option with Series 300 stainless steel bolts.

Traditional Flange Bracket Options

- B1 Bracket for 2-in. Pipe Mounting
- For use with the traditional flange option
 - Bracket for mounting on 2-in. pipe
 - Carbon steel construction with carbon steel bolts
 - Coated with polyurethane paint
- B2 Bracket for Panel Mounting
- For use with the traditional flange option
 - Bracket for mounting transmitter on wall or panel
 - Carbon steel construction with carbon steel bolts
 - Coated with polyurethane paint
- B3 Flat Bracket for 2-in. Pipe Mounting
- For use with the traditional flange option
 - Bracket for vertical mounting of transmitter on 2-in. pipe
 - Carbon steel construction with carbon steel bolts
 - Coated with polyurethane paint
- B7 B1 Bracket with SST Bolts
- Same bracket as the B1 option with Series 300 stainless steel bolts
- B8 B2 Bracket with SST Bolts
- Same bracket as the B2 option with Series 300 stainless steel bolts
- B9 B3 Bracket with SST Bolts
- Same bracket as the B3 option with Series 300 stainless steel bolts
- BA Stainless Steel B1 Bracket with SST Bolts
- B1 bracket in stainless steel with Series 300 stainless steel bolts
- BC Stainless Steel B3 Bracket with SST Bolts
- B3 bracket in stainless steel with Series 300 stainless steel bolts

Shipping Weights

TABLE 15. Transmitter Weights without Options

Transmitter	Add Weight In lb (kg)
3051C	6.0 (2,7)
3051L	Table 16 on page 37
3051H	13.6 (6,2)
3051T	3.0 (1,4)

TABLE 16. 3051L Weights without Options

Flange	Flush lb. (kg)	2-in. Ext. lb (kg)	4-in. Ext. lb (kg)	6-in. Ext. lb (kg)
2-in., 150	12.5 (5,7)	—	—	—
3-in., 150	17.5 (7,9)	19.5 (8,8)	20.5 (9,3)	21.5 (9,7)
4-in., 150	23.5 (10,7)	26.5 (12,0)	28.5 (12,9)	30.5 (13,8)
2-in., 300	17.5 (7,9)	—	—	—
3-in., 300	22.5 (10,2)	24.5 (11,1)	25.5 (11,6)	26.5 (12,0)
4-in., 300	32.5 (14,7)	35.5 (16,1)	37.5 (17,0)	39.5 (17,9)
2-in., 600	15.3 (6,9)	—	—	—
3-in., 600	25.2 (11,4)	27.2 (12,3)	28.2 (12,8)	29.2 (13,2)
DN 50/PN 40	13.8 (6,2)	—	—	—
DN 80/PN 40	19.5 (8,8)	21.5 (9,7)	22.5 (10,2)	23.5 (10,6)
DN 100/PN 10/16	17.8 (8,1)	19.8 (9,0)	20.8 (9,5)	21.8 (9,9)
DN 100/PN 40	23.2 (10,5)	25.2 (11,5)	26.2 (11,9)	27.2 (12,3)

TABLE 17. Transmitter Options Weights

Code	Option	Add lb (kg)
J, K, L, M	Stainless Steel Housing(T)	3.9 (1,8)
J, K, L, M	Stainless Steel Housing (C, L, H, P)	3.1 (1,4)
M5	LCD display for Aluminum Housing	0.5 (0,2)
M6	LCD display for SST Housing	1.25 (0,6)
B4	SST Mounting Bracket for <i>Coplanar</i> Flange	1.0 (0,5)
B1 B2 B3	Mounting Bracket for Traditional Flange	2.3 (1,0)
B7 B8 B9	Mounting Bracket for Traditional Flange	2.3 (1,0)
BA, BC	SST Bracket for Traditional Flange	2.3 (1,0)
B5 B6	Mounting Bracket for 3051H	2.9 (1,3)
H2	Traditional Flange	2.4 (1,1)
H3	Traditional Flange	2.7 (1,2)
H4	Traditional Flange	2.6 (1,2)
H7	Traditional Flange	2.5 (1,1)
FC	Level Flange—3 in., 150	10.8 (4,9)
FD	Level Flange—3 in., 300	14.3 (6,5)
FA	Level Flange—2 in., 150	10.7 (4,8)
FB	Level Flange—2 in., 300	14.0 (6,3)
FP	DIN Level Flange, SST, DN 50, PN 40	8.3 (3,8)
FQ	DIN Level Flange, SST, DN 80, PN 40	13.7 (6,2)

LCD display CONFIGURATION (Software Adjustable – M5 or M6 option must be specified in model number)

Meter Display Type⁽⁴⁾:

<input type="checkbox"/> Eng. Units only	<input type="checkbox"/> Alternate Eng. Units &% of Range ★
<input type="checkbox"/> % of Range only	<input type="checkbox"/> Alternate Eng. Units & Custom Display ⁽⁵⁾
<input type="checkbox"/> Custom Display only	<input type="checkbox"/> Alternate % of Range & Custom Display ⁽⁵⁾

Custom Display Configuration: (must be filled out if Custom Display is selected as meter type)

Decimal Point Position (fixed)—
 indicate decimal point location: X_□ X_□ X_□* X_□ X_□

Enter Lower Range Value (Decimal point must be in the same position as specified above.)
 (circle sign) + - □_□ □_□ □_□ □_□ □_□ □_□ +000.00 ★

Enter Upper Range Value (Decimal point must be in the same position as specified above.)
 (circle sign) + - □_□ □_□ □_□ □_□ □_□ □_□ +100.00 ★

Custom Units—spaces consume A-Z, 0-9, /, *, %, blank
 □ □ □ □ □ %RNGE ★

Custom Display Transfer Function (Independent of Analog Output)
 Linear ★ Square Root

HARDWARE SELECTABLE INFORMATION

Alarm Option: High Low
 Transmitter Security: Off On

Note: Specify C4 Option in model structure when ordering NAMUR-compliant alarm and saturation limits.⁽⁵⁾

SIGNAL SELECTION: (Software Selectable)

4–20 mA with simultaneous digital signal based on HART protocol★
 Burst mode of HART digital process variable ⁽⁴⁾

Burst mode output options:

Primary variable in engineering units
 Primary variable in percent of range
 All dynamic variables in engineering units and the primary variable mA value

Multidrop Communication⁽⁴⁾⁽⁶⁾ Choose transmitter address⁽⁷⁾ (1-15): _____

(4) C1 option required for configuration of this parameter.
 (5) Not available with low power output.
 (6) This option fixes the transmitter analog output at 4mA.
 (7) Default address is 1 if multidrop communication is selected.

3051C Differential/Gage Pressure Transmitter Range Limits										
Units	Range 1 Span		Range 2 Span		Range 3 Span		Range 4 Span		Range 5 Span	
	min	max	min	max	min	max	min	max	min	max
inH ₂ O	0.5	25	2.5	250	10	1000	83.040	8304	553.60	55360
inHg	0.03678	1.8389	0.18389	18.389	0.73559	73.559	6.1081	610.81	40.720	4072.04
ftH ₂ O	0.04167	2.08333	0.20833	20.8333	0.83333	83.3333	6.9198	691.997	46.13	4613.31
mmH ₂ O	12.7	635.5	63.553	6355	254	25421	2110.95	211095	14073	1407301
mmHg	0.93416	46.7082	4.67082	467.082	18.6833	1868.33	155.145	15514.5	1034.3	103430
psi	0.01806	0.903	0.0902	9.03183	0.36127	36.127	3	300	20	2000
bar	0.00125	0.06227	0.00623	0.62272	0.02491	2.491	0.20684	20.6843	1.37895	137.895
mbar	1.2454	62.2723	6.22723	622.723	24.9089	2490.89	206.843	20684.3	1378.95	137895
g/cm ²	1.26775	63.3875	6.33875	633.875	25.355	2535.45	210.547	21054.7	1406.14	140614
kg/cm ²	0.00127	0.0635	0.00635	0.635	0.0254	2.54	0.21092	21.0921	1.40614	140.614
Pa	124.545	6227.23	622.723	62160.6	2490.89	249089	20684.3	2068430	137895	13789500
kPa	0.12545	6.2272	0.62272	62.2723	2.49089	249.089	20.6843	2068.43	137.895	13789.5
torr	0.93416	46.7082	4.67082	467.082	18.6833	1868.33	155.145	15514.5	1034.3	103430
atm	0.00123	0.06146	0.00615	0.61460	0.02458	2.458	0.20414	20.4138	1.36092	136.092

When using a HART communicator, ±5% adjustment is allowed on the sensor limit to allow for unit conversions.

3051L/3051H Pressure Transmitter Range Limits									
Units	Range 2 Span		Range 3 Span		Range 4 Span		Range 5 Span		
	min	max	min	max	min	max	min	max	
inH ₂ O	2.5	250	10	1000	83.040	8304	553.60	55360	
inHg	0.18389	18.389	0.73559	73.559	6.1081	610.81	40.720	4072.04	
ftH ₂ O	0.20833	20.8333	0.83333	83.3333	6.9198	691.997	46.13	4613.31	
mmH ₂ O	63.553	6355	254	25421	2110.95	211095	14073	1407301	
mmHg	4.67082	467.082	18.6833	1868.33	155.145	15514.5	1034.3	103430	
psi	0.0902	9.03183	0.36127	36.127	3	300	20	2000	
bar	0.00623	0.62272	0.02491	2.491	0.20684	20.6843	1.37895	137.895	
mbar	6.22723	622.723	24.9089	2490.89	206.843	20684.3	1378.95	137895	
g/cm ²	6.33875	633.875	25.355	2535.45	210.547	21054.7	1406.14	140614	
kg/cm ²	0.00635	0.635	0.0254	2.54	0.21092	21.0921	1.40614	140.614	
Pa	622.723	62160.6	2490.89	249089	20684.3	2068430	137895	13789500	
kPa	0.62272	62.2723	2.49089	249.089	20.6843	2068.43	137.895	13789.5	
torr	4.67082	467.082	18.6833	1868.33	155.145	15514.5	1034.3	103430	
atm	0.00615	0.61460	0.02458	2.458	0.20414	20.4138	1.36092	136.092	

When using a HART communicator, ±5% adjustment is allowed on the sensor limit to allow for unit conversions.

3051T Gage and Absolute Pressure Transmitter Range Limits										
Units	Range 1 Span		Range 2 Span		Range 3 Span		Range 4 Span		Range 5 Span	
	min	max	min	max	min	max	min	max	min	max
inH ₂ O	8.30397	831.889	41.5198	4159.45	221.439	22143.9	1107.2	110720	55360	276799
inHg	0.61081	61.0807	3.05403	305.403	16.2882	1628.82	81.441	8144.098	4072.04	20360.2
ftH ₂ O	0.69199	69.3241	3.45998	345.998	18.4533	1845.33	92.2663	9226.63	4613.31	23066.6
mmH ₂ O	211.10	21130	1054.60	105460.3	5634.66	563466	28146.1	2814613	1407301	7036507
mmHg	15.5145	1551.45	77.5723	7757.23	413.72	41372	2068.6	206860.0	103430	517151
psi	0.3	30	1.5	150	8	800	40	4000	2000	10000
bar	0.02068	3.06843	0.10342	10.3421	0.55158	55.1581	2.75791	275.7905	137.895	689.476
mbar	20.6843	2068.43	103.421	10342.11	551.581	55158.1	2757.91	275790.5	137895	689476
g/cm ²	21.0921	2109.21	105.461	10546.1	561.459	56145.9	2807.31	280730.6	140614	703067
kg/cm ²	0.02109	2.10921	0.10546	10.5461	0.56246	56.2456	2.81228	281.228	140.614	701.82
Pa	2068.43	206843	10342.1	1034212	55158.1	5515811	275791	27579054	13789500	68947600
kPa	2.06843	206.843	10.3421	1034.21	55.1581	5515.81	275.791	27579.05	13789.5	68947.6
torr	15.5145	1551.45	77.5726	7757.26	413.721	413721	2068.6	206859.7	103430	517151
atm	0.02041	2.04138	0.10207	10.2069	0.54437	54.4368	2.72184	272.1841	136.092	680.46

When using a HART communicator, ±5% adjustment is allowed on the sensor limit to allow for unit conversions.

3051C Absolute Pressure Transmitter Range Limits									
Units	Range 1 Span		Range 2 Span		Range 3 Span		Range 4 Span		
	min	max	min	max	min	max	min	max	
inH ₂ O	8.30397	831.889	41.5198	4151.98	221.439	22143.9	1107.2	110720	
inHg	0.61081	61.0807	3.05403	305.403	16.2882	1628.82	81.441	8144.098	
ftH ₂ O	0.69199	69.3241	3.45998	345.998	18.4533	1845.33	92.2663	9226.63	
mmH ₂ O	211.10	21130	6.35308	635.308	5634.66	563466	28146.1	2814613	
mmHg	15.5145	1551.45	1055.47	105547	413.72	41372	2068.6	206860.0	
psi	0.3	30	1.5	150	8	800	40	4000	
bar	0.02068	2.06843	0.10342	10.342	0.55158	55.1581	2.75791	275.7905	
mbar	20.6843	2068.43	103.421	10342.1	551.581	55158.1	2757.91	275790.5	
g/cm ²	21.0921	2109.21	105.27	105.27	561.459	56145.9	2807.31	280730.6	
kg/cm ²	0.02109	2.10921	0.10546	10.546	0.56246	56.2456	2.81228	281.228	
Pa	2068.43	206843	10342.1	1034210	55158.1	5515811	275791	27579054	
kPa	2.06843	206.843	10.3421	1034.21	55.1581	5515.81	275.791	27579.05	
torr	15.5145	1551.45	77.5726	7757.26	413.721	413721	2068.6	206859.7	
atm	0.02041	2.04138	0.10207	10.207	0.54437	54.4368	2.72184	272.1841	

When using a HART communicator, ±5% adjustment is allowed on the sensor limit to allow for unit conversions.

Product Data Sheet

00813-0100-4001, Rev FA
August 2004

Rosemount 3051

*Rosemount, Annubar, ProPlate, and the Rosemount logotype are registered trademarks of Rosemount Inc.
PlantWeb is a registered trademark of one of the Emerson Process Management group of companies.
Complete Point Solutions, Coplanar and Multivariable are trademarks of Rosemount Inc.
HART is a registered trademark of the HART Communications Foundation.
Hastelloy is a registered trademarks of Haynes international, Inc..
Monel is a registered trademark of the Special Metals Corporation group of Companies.
Syltherm 800, Dow Corning, and D.C. are registered trademarks of Dow Corning Co.
Teflon is a registered trademark of E.I. du Pont de Nemours & Co.
Neobee M-20 is a registered trademark of Stephan Chemical Co.
The 3-A symbol is a registered trademark of the 3-A Sanitary Standards Symbol Council.
FOUNDATION fieldbus is a registered trademark of the Fieldbus Foundation.
Fluorinert is a registered trademark of 3M Company.*

All other marks are the property of their respective owners.

Rosemount Model 3051 Smart Pressure Transmitters may be protected by one or more of the following U.S. Patent Nos. 4,370,890; 4,466,290; 4,612,812; 4,791,352; 4,798,089; 4,818,994; 4,833,922; 4,866,435; 4,926,340; 4,988,990; and 5,028,746. Mexico Patentado No. 154,961. May depend on model. Other foreign patents issued and pending.

Emerson Process Management

Rosemount Inc.
8200 Market Boulevard
Chanhassen, MN 55317 USA
T (U.S.) 1 800 999 9307
T (International) (952) 906 8888
F (952) 949 7001

www.rosemount.com

**Emerson Process Management
GmbH & Co.**
Argelsrieder Feld 3
82234 Wessling
Germany
T 49 (8153) 9390
F 49 (8153) 939172

**Emerson Process Management Asia
Pacific Private Limited**
1 Pandan Crescent
Singapore 128461
T (65) 6777 8211
F (65) 6777 0947
AP.RMT-Specialist@emersonprocess.com

**Beijing Rosemount Far East
Instrument Co., Limited**
No. 6 North Street,
Hepingli, Dong Cheng District
Beijing 100013, China
T (86) (10) 6428 2233
F (86) (10) 6422 8586

