

# SUPPORT MATERIAL FOR BIOLOGY FOR CLASS XII

---

## MEMBERS WHO REVIEWED SUPPORT MATERIAL

---

<i>Sl. No.</i>	<i>Name</i>	<i>Designation</i>	<i>School</i>
1.	<b>Mr. S.D. Sharma</b> <i>(Team Leader)</i> (9868341155)	<i>Principal</i>	Rajkiya Pratibha Vikas Vidyalaya, Raj Niwas Marg, Delhi-110054
2.	<b>Mr. Ranveer Singh</b> (9891069977)	<i>Lecturer</i> <i>(Biology)</i>	Sarvodaya Bal Vidyalaya Timar Pur, Delhi-110054
3.	<b>Mr. R.P. Singh</b> (M. 9990081661)	<i>Lecturer</i> <i>(Biology)</i>	Rajkiya Pratibha Vikas Vidyalaya Kishan Ganj, Delhi – 110007

# CLASS XII BIOLOGY (THEORY)

## *Design of the Question Paper*

**Maximum Marks : 70**

**Duration : 3 Hours**

The weightage of the distribution of marks over different dimensions of the question paper shall be as follows :

### 1. Weightage of Content/Subject Units

<i>Units</i>	<i>Content</i>	<i>Marks</i>
1.	Reproduction	14
2.	Genetics and Evolution	18
3.	Biology and Human Welfare	14
4.	Biotechnology and its application	10
5.	Ecology and Environment	14
<b>Total</b>		<b>70</b>

### 2. Weightage of Different Form of Questions

<i>S.No.</i>	<i>Form of Questions</i>	<i>Marks for each</i>	<i>No. of Questions</i>	<i>Total Marks</i>
1.	Very Short Answer (VSA)	1	8	08
2.	Short Answer (SA II)	2	10	20
3.	Short Answer (SA I)	3	09	27
4.	Long Answer (LA)	5	3	15
<b>Total</b>		<b>–</b>	<b>30</b>	<b>70</b>

### 3. Scheme of Option

1. Three will be no overall option.

2. Internal choice (either/or type) on a very selective basis has been provided. The choice has been given in one question of 2 marks, one question of 3 marks and all the three questions of 5 marks weightage.

4. Weightage to difficulty level of questions

<b>S. No.</b>	<b><i>Estimated Difficulty Level</i></b>	<b><i>Percentage</i></b>
1.	Easy	15
2.	Average	70
3.	Difficult	15

About 20% weightage has been assigned to questions testing higher order thinking skills of learners.

---

# CONTENTS

---

<b>S.No.</b>	<b>Chapter</b>	<b>Page</b>
1.	Reproduction in Organisms	5
2.	Sexual Reproduction in Flowering Plants	9
3.	Human Reproduction	16
4.	Reproductive Health	24
5.	Principles of Inheritance and Variation	29
6.	Molecular Basis of Inheritance	35
7.	Evolution	44
8.	Human Health and Disease	50
9.	Strategies for Enhancement in Food Production	58
10.	Microbes in Human Welfare	64
11.	Biotechnology : Principles and Processes	70
12.	Biotechnology and Its Applications	78
13.	Organisms and Populations	85
14.	Ecosystem	93
15.	Biodiversity and Conservation	99
16.	Environmental Issues	106
	<i>Model Papers</i>	112

## CHAPTER 1

# REPRODUCTION IN ORGANISMS

## POINTS TO REMEMBER

**Bulbils** : These are small, fleshy buds which develop into new plants as in *Agave*.

**Clone** : A group of organism derived from a single individual and hence morphologically and genetically similar.

**Embryogenesis** : The process of development of embryo from zygote.

**Gametogenesis**: The process of formation of male and female gametes.

**Isogamete** : One of a pair of conjugating gametes.

**Juvenile Phase** : It is the period of growth before maturity when sex organs are not functional.

**Meiocytes** : These are specialized cells of diploid organisms which undergo meiosis.

**Pericarp** : It is the protective covering of fruit, may be divided into epicarp, mesocarp and endocarp.

**Parthenogenesis** : Development of an egg into an embryo without fertilisation.

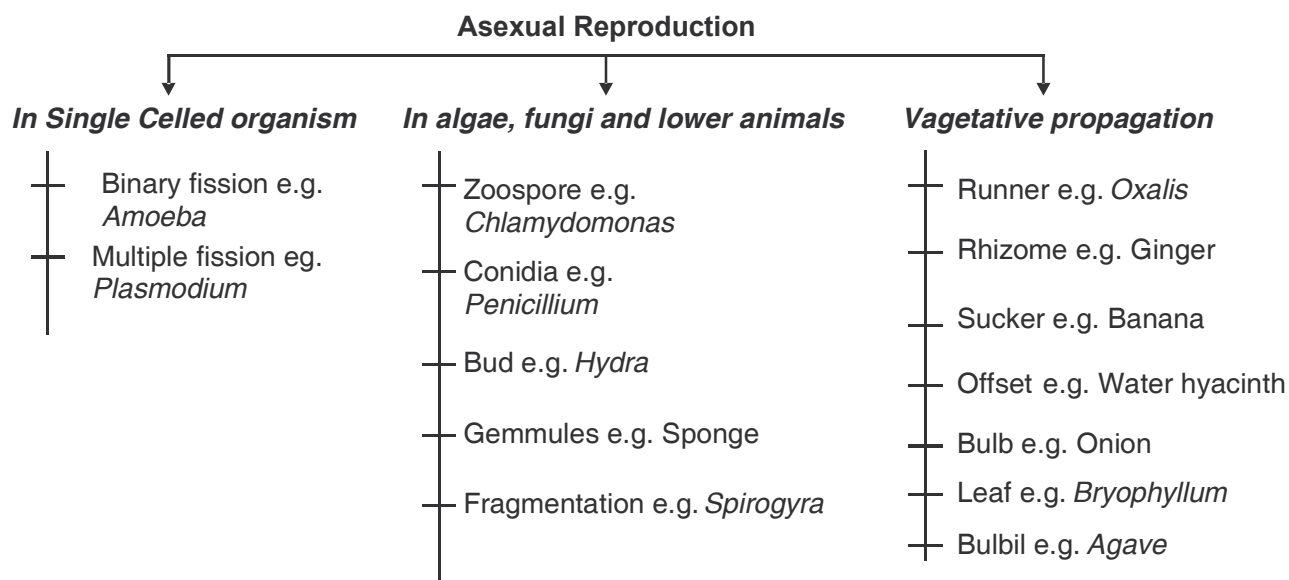

### Gamete Transfer

1. **In Algae, Bryophytes and Pteridophytes** : The male and female gametes are flagellated and motile, need a medium (water) to reach the egg.

2. **In seed Plants** : Pollen grains are transferred to stigma of flower of same species by various agents.
3. **In animals** :
  - (a) By Copulation – *e.g.*, Reptiles, Birds and Mammals.
  - (b) By External medium – *e.g.*, Fishes and Amphibians.

---

## QUESTIONS

---

### VSA (I MARK)

1. Offsprings produced by asexual reproduction are referred to as clones. Why?
2. Name the most invasive aquatic plant weed which is called as 'Terror of Bengal'.
3. How does Zygote usually differ from Zoospore in terms of ploidy?
4. Mention the main difference between the offspring produced by asexual reproduction and progeny produced by sexual reproduction.
5. Which characteristic property of *Bryophyllum* is exploited by gardeners and farmers?

### SA – II (2 MARKS)

6. Higher organism have resorted to sexual reproduction inspite of its complexity. Why?
7. Tapeworms posses both male and female reproductive organs. What is the name given to such organism? Give two more examples of such organisms.
8. Study the relationship between first two words and suggest a suitable word for fourth place.
  - (a) Male flower : Stamens :: Female Flower : .....
  - (b) Birds : oviparous :: Primates : .....
  - (c) *Chlamydomonas* : Zoospores :: *Penicilium* : .....
  - (d) Ginger : Rhizome :: *Agave* : .....
9. Bryophytes and Pteridophytes produce a large number of male gametes but relatively very few female gametes. Why?

### SA – I (3 MARKS)

10. Mention the site of zygote formation in the ovule of a flowering plant. What happens to sepals, petals and stamens after fertilisation? State the fate of zygote, ovule and ovary in these plants.
11. Distinguish between gametogenesis and embryogenesis.

12. Fill the blank spaces a, b, c, and d given in the following table.

<b>Organism</b>	<b>Organ</b>	<b>Gamete</b>
a	Testes	Spermatozoa
Human female	b	Ovum
Plant (Angiosperm)	c	Pollen grains
Plant (pteridophytes)	antheridium	d

### LA (5 MARKS)

13. (a) Distinguish between asexual and sexual reproduction. Why is vegetative reproduction also considered as a type of asexual reproduction?
- (b) Which is better mode of reproduction : Sexual or Asexual? Why?

### ANSWERS

#### VSA (I MARK)

1. Because offsprings produced by Asexual reproduction is morphologically and genetically identical to parent.
2. Water hyacinth (*Eicchornia*)
3. Zygote – diploid, zoospore – haploid.
4. Offspring produced by asexual reproduction are genetically similar while progeny produced by sexual reproduction exhibit genetic variation.
5. Adventitious bud arising from margin of the leaf.

#### SA – II (2 MARKS)

6. Because of variations, gene pool, Vigour and Vitality and Parental care.
7. Hermaphrodite; Examples : Earthworm, Leech.
8. (a) Carpel (b) Viviparous (c) Conidia (d) Bulbil
9. Because male gamete need medium (water) to reach egg/female gamete. A large number of the male gametes fail to reach the female gamete.

#### SA – I (3 MARKS)

10. Embryo sac

Sepals, Petals and Stamens dry and fall off. Zygote develops into embryo. Ovule develops into seed and ovary into fruit.

11.

<i><b>Gametogenesis</b></i>	<i><b>Embryogenesis</b></i>
1. Formation of gametes	1. Formation of Embryo
2. Produces haploid gametes	2. Embryo is diploid
3. Cell division is meiotic	3. Cell division is mitotic.

12. a = Human male  
c = Anther

b = ovary  
d = Antherozoid

**LA (5 MARKS)**

13. (a)

<i><b>Asexual Reproduction</b></i>	<i><b>Sexual Reproduction</b></i>
(i) Uniparental	(i) Biparental
(ii) Gametes are not involved	(ii) Gametes are involved
(iii) Only mitotic division takes place	(iii) Meiosis at the time of gamete formation and mitosis after fertilisation
(iv) Offspring genetically similar to parent	(iv) Offspring different from parent.

Vegegate propagation takes plce when new individuals arise from vegetative part of parent and have characters similar to that of parent plant.

(b) Sexual reproduction introduces variations in offsprings and has evolutionary significance. It helps offsprings to adjust according to the changes in environment. It produces better offsprings due to character combination.



## CHAPTER 2

---

# SEXUAL REPRODUCTION IN FLOWERING PLANTS

---

---

### POINTS TO REMEMBER

---

**Autogamy** : When pollen grains of a flower are transferred from anther to stigma of the same flower.

**Coleorhiza** : A protective sheath of radicle in monocot seed.

**Coleoptile** : A protective sheath of plumule in monocot seed.

**Endothecium** : A fibrous layer in the anther next to epidermis.

**Geitonogamy** : Self pollination between flowers of the same plant.

**Micropyle** : A small pore in the ovule through which the pollen tube enters.

**Nucellus** : Multicellular tissue in the centre of ovule where embryo sac is present.

**Tapetum** : Nutritive layer of cells around pollen sac.

**Viability of Seed** : Ability of seed to retain the power of germination.

1. **Micro sporangium (Pollen sac)** :

Outermost layer = Epidermis

Second layer = Endothecium

Middle layer = 2 – 4 layers of cells

Innermost layer = Tapetum [Nourishes the developing Pollen grains (Microspores)]

2. **Microsporogenesis** : Process of formation of microspores

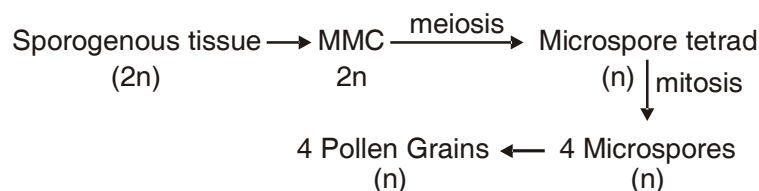

3. **Pollen grain** →

- outerwall (Exine) – Thick, hard, made of sporopollenin
- innerwall (Intine) – Thin, made of cellulose and Pectin
- cell – a vegetative cell (large in size) and a generative cell (small in size)

4. Megasporogenesis – Process of formation of megaspore.

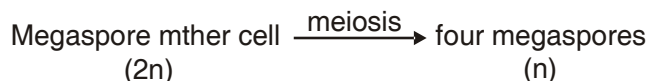

5. **Megasporangium (Ovule) :**

- The ovule is a small structure attached to the placenta by means of a stalk called funicle. The point of attachment of the body of the ovule to the funicle is known as hilum. The main body of the ovule is composed of paranchymatous cells known as nucellus.
- Each ovule has one or two protective integument, which encircle the ovule except at the tip having small opening called micropyle.
- Opposite to micropylar end, is chalaza.
- Generally a single embryo sac or female gametophyte located in nucellus.
- Cells of nucellus have abundant reserve food material.

6. **Female gametophyte (Embryo sac) :** In a majority of flowering plant one of the megaspore is functional while other three degenerate.

- The functional megaspore develops in embryo sac.
- The nucleus of the functional megaspore (n) undergoes three successive mitotic cell division which results the formation of eight nucleate stage of embryo sac (free nuclear division)
- The cell wall formation starts at eight nuclear stages. Three cells are grouped together at micropylar end to form the egg apparatus (2 synergids + 1 egg cell).
- Three cells are grouped at chalazal end, called antipodal cells.
- The remaining 2 nuclei are called polar nuclei move to the centre of embryo sac, called central cell.

Thus typical angiospermic embryo sac at maturity is 8 nucleated and 7 celled.

7. **Pollen – pistil interaction**

- The pistil has the ability to recognize the pollen, whether it is or right type (Compatible) or of the wrong type (incompatible).
- If it is compatible, the pistil accepts the pollen.
- The pollen grains germinate on stigma to produce tubes. The contents of the generative cell (or the two male gametes in those species whose pollen is liberated in the three celled stage).
- Pollen tube grows through the tissue of stigma and style by secreting enzyme and enters the ovule.

8. **Double Fertilisation :** The pollen tube releases two male gamete into the cytoplasm of synergid

**Syngamy** : One male gamete + Egg cell → Zygote (2n)

**Triple Fusion** : Second male gamete + 2 polar nuclei → PEN (3n)

9. **Post Fertilisation events** : (i) Endosperm and embryo development (ii) Maturation of ovule and ovary

---

Ovary	Fruit	(2n)
Ovary wall	Pericarp	(2n)
Ovule	Seed	(2n)
Outer Integument	Testa	(2n)
Inner Integument	Tegmen	(2n)
Zygote	Embryo	(2n)
Primary Endosperm cell	Endosperm	(3n)

---

Embryo formation starts after certain amount of endosperm is formed

Zygote → Pro-embryo → Globular embryo → Heart shaped embryo → Mature embryo

10. **Dicot Embryo** : A typical dicot embryo consist of an embryonal axis and two cotyledons. The portion of embryonal axis above the level of cotyledons is the epicotyle which terminates with the plumule or stem tip.

The portion below the level of cotyledons is hypocotyl that terminates at its lower end in the radicle or root tip.

**Monocot Embryo** : Monocot (Rice, Maize etc.) has one cotyledon called Scutellum. The embryonal axis has the radicle and root cap enclosed by a sheath called Coleorrhiza.

The upper end (epicotyle) has plumule which is covered by hollow folder sturcture, the coleoptile.

**Apomixis** : Apomixis is a form of asexual reproduction that mimics sexual reproduction where seed are formed without fertilisation.

**Polyembryony** : Occurance of more than one embryo in a seed. e.g. Orange, lemon, onion, mango, ground nut.

*Reasons* : More than one egg may be formed in the embryo sac. More than one embryo sac may be formed in an ovule.

---

## QUESTIONS

---

### VSA (I MARK)

1. In a young anther, a group of compactly arranged homogenous cells were observed in the centre of each microsporangium. What is the name given to these cells?
2. Give the scientific name of a plant which came to India as a contaminant with imported wheat and causes pollen allergy.

3. Pollen grains of water pollinated species have a special characteristics for protection from water. What is that?
4. Why are pollen grains produced in enormous quantity in Maize?
5. In same species of Asteraceae and grasses, seed are formed without fusion of gametes. Mention the scientific term for such form of reproduction.
6. Arrange the following in correct developmental sequence :  
Male gamete, Potential pollen mother cell, sporogenous tissue, Pollen grains, Microspore tetrad.
7. If the diploid number of chromosomes in an angiospermic plant is 16. Mention number of chromosomes in the endosperm and antipodal cell.

### SA - II (2 MARKS)

8. In angiospermic plant before formation of microspore sporogenous tissue undergo cell division
  - (a) Name the type of cell division.
  - (b) What would be the ploidy of the cells of tetrad?
9. Outer envelop of pollen grain made of a highly resistant substance. What is that substance? At which particular point the substance is not present?
10. Fruits generally develops from ovary, but in few species thalamus contributes to fruit formation.
  - (a) Name the two categories of fruits.
  - (b) Give one example of each.
11. Among the animal, insects particularly bees are the dominant pollinating agents. List any four characteristic features of the insect pollinated flower.
12. Differentiate between geitonogamy and xenogamy.
13. In the given figure of a dicot embryo, label the parts (A) and (B) and give their function.

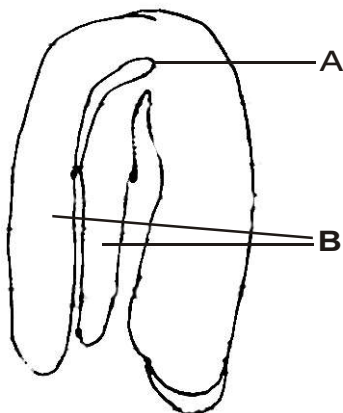

Figure 1

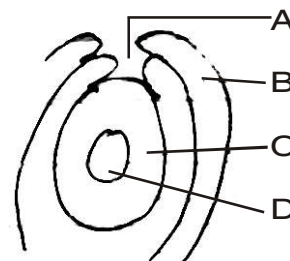
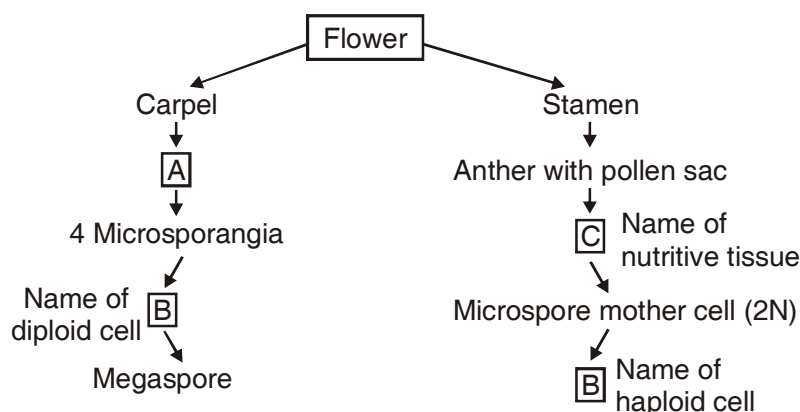

Figure 2

14. Name the parts A, B, C and D of the anatropous ovule (Figure 2) given above.
15. Given below is an incomplete flow chart showing formation of gamete in angiospermic plant. Observe the flow chart carefully and fill in the blank A, B, C and D.



16. Name the blank spaces a, b, c and d in the table given below :

<i>Item</i>	<i>What it represents in the plant</i>
(i) Pericarp	a
(ii) b	Cotyledon in seeds of grass family
(iii) Embryonal axis	c
(iv) d	Remains of nucellus in a seed.

17. Even though each pollen grain has two male gametes. Why are at least 10 pollen grains and not 5 pollen grains required to fertilise 10 ovules present in a particular carpel?

### SA - I (3 MARKS)

18. Continued self pollination lead to inbreeding depression. List three devices, which flowering plant have developed to discourage self pollination?
19. What will be the fate of following structures in the angiospermic plant? Ovary wall, Ovule, zygote, outer integument Inner integument and primary endosperm nucleus.
20. Differentiate between micro sporogenesis and mega sporogenesis. What type of cell division occurs during these events. Name the structure formed at the end of these two events.

### LA (5 MARKS)

21. Draw the Embryo sac of a flowering plants and label :

(a) (i) Central Cell                      (ii) Chalazal end                      (iii) Synergids

- (b) Name the cell that develops into embryo sac and explain how this cell leads to formation of embryo sac.
- (c) Mention the role played by various cells of embryo sac.
- (d) Give the role of filiform apparatus.

---

## ANSWERS

---

1. Sporogenous tissue
2. *Parthenium*
3. Presence of mucilaginous covering
4. To ensure pollination because Maize is pollinated by wind.
5. Apomixis
6. Sporogenous tissue – Potential pollen mother cell – microspore tetrad – Pollen grain – male gamete.
7. 24 Chromosomes in endosperm and 16 chromosomes in antipodal cell.

### SA – II (2 MARKS)

8. (a) meiosis division (b) haploid
9. Sporopollenin; at germ pore sporopollenin is absent.
10. Two categories of fruits are :
- (i) True fruits *e.g.*, Mango
  - (ii) False fruit *e.g.*, Apple
11.
  1. Flowers are large.
  2. Colorful petals of flower.
  3. Presence of fragrance.
  4. Rich in nectar.
- 12.

---

<i>Geitonogamy</i>	<i>Xenogamy</i>
1. Transfer of pollen grains from the anther to stigma of another flower of the same plant.	Transfer of Pollen grains from another to Stigma of different plant.
2. Does not provide opportunity for gametic recombination.	Provide opportunity for gametic recombination.

---

13. A = Plumule – To form shoot system  
B = Cotyledons – Storage of food
14. A = Micropyle, B = Outer integument, C = Nucellus, D = Embryo sac
15. A = Ovule/megasporangium, C = Tapetum  
B = Megaspore mother cell, D = Pollen grains
16. (a) = wall of fruit, b = scutellum, c = shoot and root tip, d = perisperm
17. Because only one male gamete is involved in syngamy.

### SA – I (3 MARKS)

18. (a) Release of pollen and stigma receptivity is not synchronised in some species  
(b) Anther and stigma are at different position/heights in some plants  
(c) Self-incompatibility.
19. Ovary wall = Pericarp ; Ovule = Seed,  
Zygote - Embryo; Outer integument = Testa;  
Inner integument = Tegmen; Primary endosperm nucleus = Endosperm.
20. Microsporogenesis – Process of formation of microspore from a Pollen mother cell.  
Megsporogenesis – Process of formation of megaspore from megaspore mother cell.  
Meiotic division in both  
  
Microsporogenesis results in the formation of pollen grain while megasporogenesis results in the formation of megaspore.

### LA (5 MARKS)

21. A. Refer to figure 2.8(c) page 26 NCERT book.  
B. Functional Megaspore, Refer text on page 27 NCERT book.  
C. Egg : Fuses with male gamete to form zygote or future embryo  
Synergid : Absorption of nutrient, attract and guides pollen tube.  
Central Cell : After fusion with second male gamete forms Primary endosperm cell which gives rise to Endosperm  
D. Guides the entry of pollen tube.

## CHAPTER 3

---

# HUMAN REPRODUCTION

---

---

### POINTS TO REMEMBER

---

**Blastula** : A stage of embryogenesis which comes after morula and has a hollow fluid filled space called blastocoel.

**Endometrium** : Innermost glandular layer lining the uterine cavity.

**Foetus** : An advanced stage of embryo within the uterus.

**Gestation Period** : A period between fertilisation of ovum and the birth of a baby.

**Hymen** : A thin membrane partially covering the vaginal aperture.

**Implantation** : Fixing of embryo/fertilized egg in uterus. It leads to pregnancy.

**Menarche** : The beginning of first menstruation in female on attaining puberty.

**Menopause** : Permanent cessation of menstrual cycle in female. It occurs between the age 45 to 50 years in human female.

**Oogenesis** : Formation and development of ova in ovary.

**Ovulation** : Process of release of mature ovum (Secondary oocyte) from the ovary.

**Parturition** : Process of delivery of the foetus (Child birth).

**Puberty** : A stage at which immature reproductive system of boy or girl becomes mature.

**Scrotum** : A muscular pouch which houses two testes.

**Spermatogenesis** : Process of formation of sperm from male germ. Cell in the testes.

*Contd...*



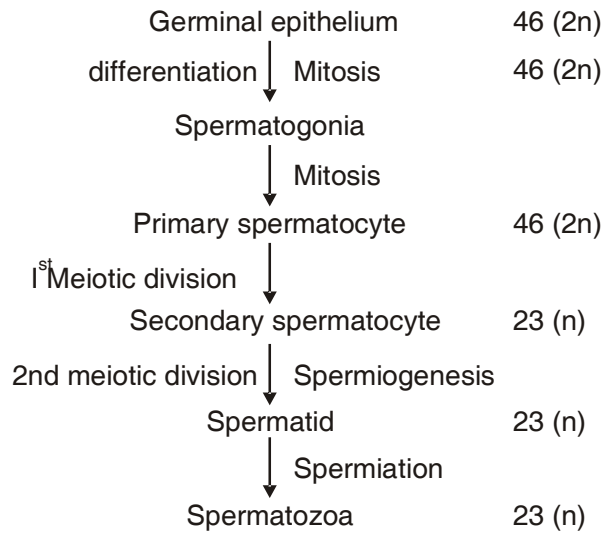

**Oogenesis** : Process of formation of ova in ovary

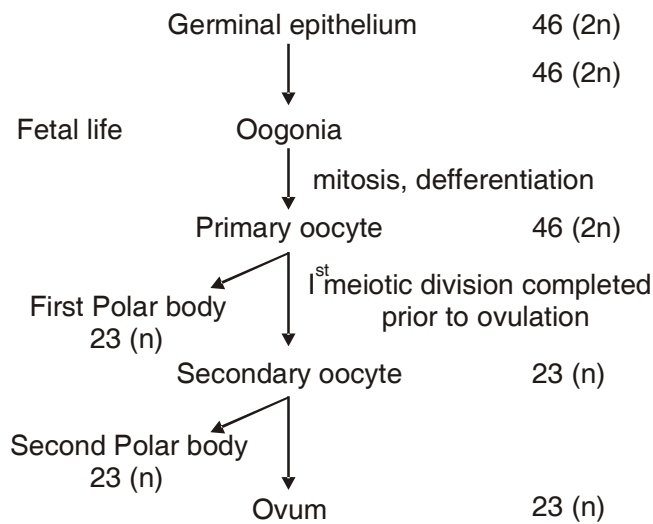

**Phases of Menstrual Cycle** : Menstrual phase, Follicular (Proliferative) Phase, ovulatory phase and Luteal (secretory) phase

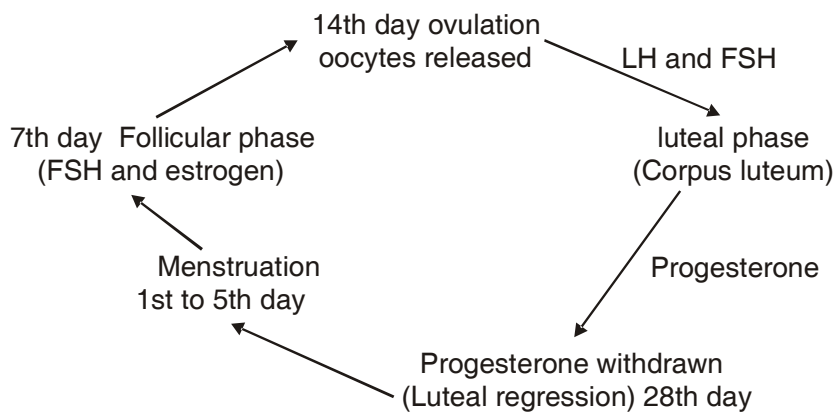

**Fertilisation** : Process of fusion of sperm with ovum

**Site of fertilisation in human female** : Ampullary – isthmic junction

Secretion of acrosome helps the sperm entry into cytoplasm of ovum through zona pellucida and plasma membrane. Sperm entry induce the completion of the 2nd meiotic division of secondary oocyte.

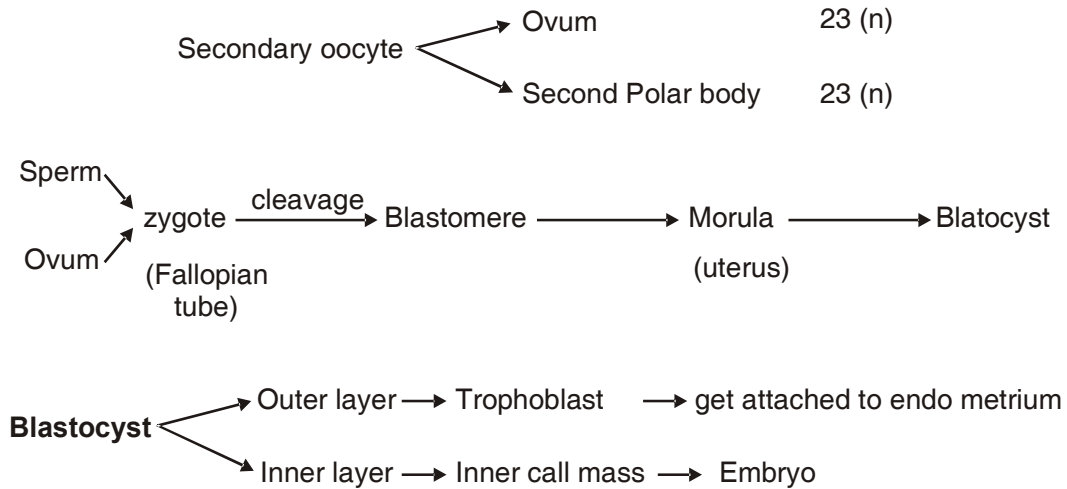

**Placenta** : An intimate connection between foetus and uterine wall of the mother to exchange materials.

**Function of Placenta** : Nutrition, Respiration, Excretion, as barrier, Endocrine function.

**Placenta as Endocrine tissue** : Placenta Produces several hormones such as – Estrogen, hcG, hPL, Progesterone and relaxin (in late phase of pregnancy).

**Embryonic Development** : at various month of Pregnancy After–1 month = Heart, 2 months = Limbs and digits, 3 months = External genital organ, 5 months = First movement, 6 months = body covered with fine hairs, eye lid, eye lashes, 9 months = Fully developed and ready for delivery.

### VSA (I MARK)

1. Failure of testes to descend into scrotal sacs leads to sterility. Why?
2. Both vaccine and colostrum produce immunity. Name type of immunity produced by these.
3. How many sperms will be produced from 10 primary spermatocytes and how many eggs will be produced from 10 primary oocytes?
4. The spermatogonial cell has 46 chromosomes in human male. Give the number of chromosomes in –
  - (a) Primary spermatocyte
  - (b) Spermatid
5. In ovary which structure transforms as corpus luteum and name the hormone secreted by corpus luteum?

6. "Each and every coitus does not results in fertilisation and pregnancy". Justify the statement.

**VSA – II (2 MARKS)**

7. Give the function of

(a) Corpus luteum

(b) Endometrium

8. In the given figure, give the name and functions of parts labelled A and B.

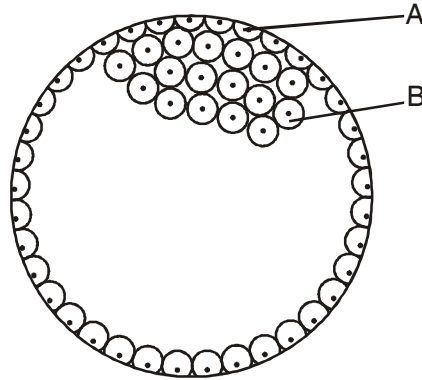

9. Given below is an incomplete flow chart showing influence of hormone on gametogenesis in male, observe the flow chart carefully and fill in the blank A, B, C and D.

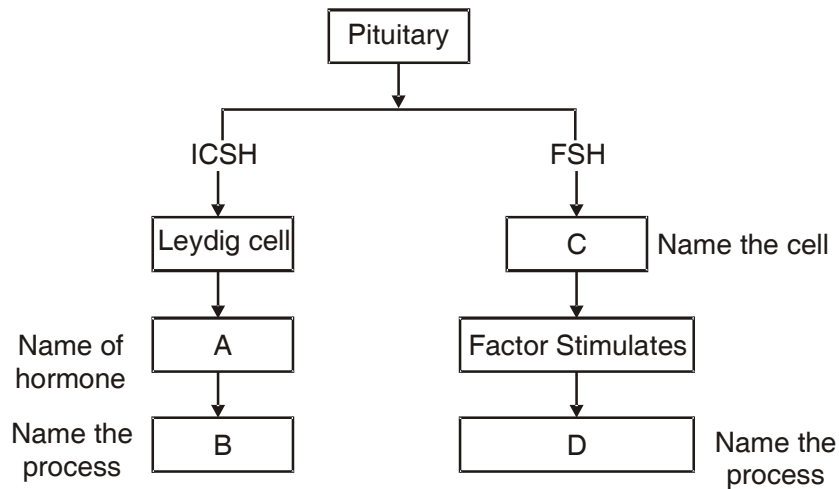

10. Give reason for the following :

(a) The first half of the menstrual cycle is called follicular phase as well as proliferative phase.

(b) The second half of the menstrual cycle is called luteal phase as well as secretory phase.

11. What is meant by L.H. Surge? Write the role of L.H.

12. Explain significance of the condition in which the testes remain suspended in scrotum outside the abdomen.

**SA - I (3 MARKS)**

13. Mention the name and role of hormones which are involved in regulation of gamete formation in human male.
14. Three of the steps of neuro endocrine mechanism in respect of parturition are mentioned below. Write the missing steps in proper sequence.
- Signals originate from fully developed foetus and placenta.
  - \_\_\_\_\_.
  - \_\_\_\_\_.
  - Oxytocin causes strong uterine contraction
  - Uterine contraction stimulates further secretion of oxytocin.
  - \_\_\_\_\_.
15. The events of the menstrual cycle are represented below. Answer the following questions.

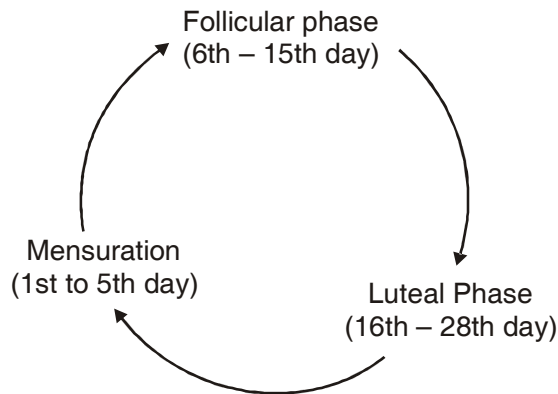

- State the levels of FSH, LH and Progesterone simply by mentioning high or low around 13th and 14th day and 21st to 23rd day.
  - In which of the above mentioned phases does egg travel to fallopian tube?
  - Why there is no mensuration after fertilisation?
16. (a) Read the graph given below. Correlate the ovarian events that take place in the human female according to the level of the pituitary hormone during the following day.

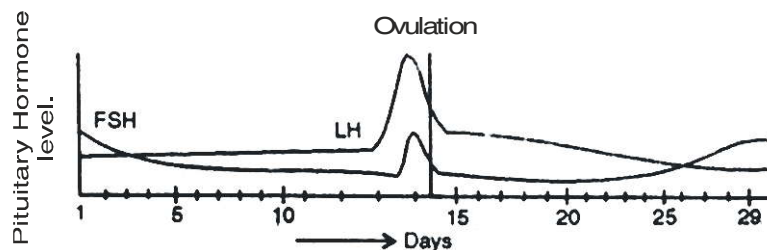

- 10th - 14th days
- 14th -15th days

(iii) 16th – 23th days

(iv) 25th – 29th days

(If the ovum is not fertilised)

(b) What are the uterine events that follow beyond 29th day if the ovum is not fertilised?

17. T.S. of mammalian testis revealing seminiferous tubules show different types of cell.

(i) Name the two types of cells of germinal epithelium.

(ii) Name of cells scattered in connective tissue and lying between seminiferous tubules.

Differentiate between them on the basis of their functions.

### LA (5 MARKS)

18.

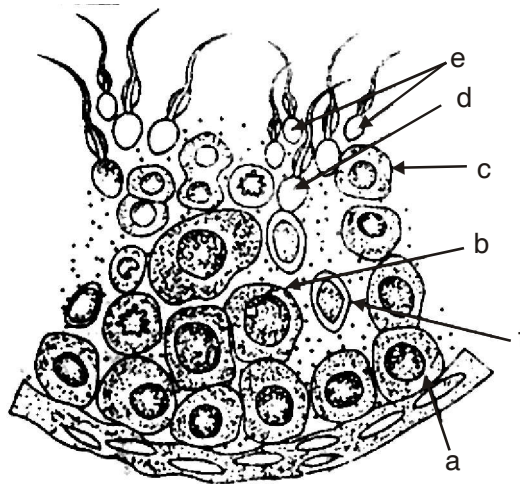

Study the figure given :

(i) Pick out and name the cells that undergo spermiogenesis.

(ii) Name 'A' and 'C' cells.

(iii) Give ploidy of 'B' and 'E'

(iv) What are the cells marked as 'F'? Mention their function.

(v) Mention the type of cell division in A and B.

## ANSWERS

### VSA (I MARK)

1. High temperature of abdomen kills the spermatogenic tissue of the testes, so no sperm are formed.

2. Vaccine – Active immunity

Colostrum – Passive immunity.

3. 40 sperms, 10 eggs.
4. (i) 46 in Primary spermatocyte  
(ii) 23 in spermatid.
5.
  - Follicular cells of empty Graafian follicle.
  - Progesterone.
6. Ovum and sperm should reach simultaneously to the ampullary - isthmic junction.

### **SA – II (2 MARKS)**

7. **Corpus luteum** : It secretes progesterone which prepares endometrium of uterus for implantation and normal development of foetus.  
  
**Endometrium** : It undergoes cyclic changes during menstrual cycle and prepares itself for implantation of blastocyst.
8. A = Trophoblast – Gets attached to endometrium and draws nutritive material secreted by uterine endometrium gland.  
  
B = Inner cell mass – Differentiates as Embryo.
9. A = Testosterone; B = Spermatogenesis  
  
C = Sertoli cells; D Spermiogenesis
10. (a) During this phase, primary follicles transform into Graafian follicle under FSH stimulation. Graafian follicles secrete Estrogens with stimulate enlargement of Endometrium of uterus.  
  
(b) During this phase, Corpus luteum is fully formed and secretes large quantity of Progesterone.
11. Refer page 51 NCERT book
12. Refer page 43 NCERT book.

### **SA – I (3 MARKS)**

13. **GnRH** : Stimulates adenophysis to secrete gonadotrophins.  
  
**GSH** : Stimulates Sertoli cells to secrete factors while help in spermatogenesis.  
  
**ICSH** : Stimulates interstitial cells to secrete testosterone.
14. (b) Foetal ejection reflex  
  
(c) The reflex triggers release of oxytocin  
  
(f) Expulsion of the baby out through birth canal.

15. (i)
- |              |       | <b>13 – 14th day</b> | <b>21st – 23rd day</b> |
|--------------|-------|----------------------|------------------------|
| FSH          | ————→ | High                 | Low                    |
| LH           | ————→ | High                 | Low                    |
| Progesterone | ————→ | Low                  | High                   |
- (ii) End of follicular or proliferative phase.
- (iii) Menstruation does not occur during pregnancy upon fertilisation due to high level of progesterone secreted by persisting corpus luteum and Placenta.
16. (a) (i) Gonadotropins and FSH increases  
(ii) LH attains peak level but FSH decreases  
(iii) LH and FSH level decreases  
(iv) LH remains low and FSH increases.
- (b) After 29th day there is a menstrual flow involving discharge of blood and cast off endometrium lining.
17. (i) Germinal epithelium have two types of cell. 1. Spermatogonium. 2. Sertoli cells  
(ii) Leydig cells or Interstitial cells.

**Functions**

Spermatogonium undergoes meiotic division leading to sperm formation.

**Sertoli cell** : Nourishes germ cells

**Leydig cell** : Synthesise and Secrete hormone androgen.

**LA (5 MARKS)**

18. (i) 'D' Spermatids = undergo spermiogenesis  
(ii) 'A' = Spermatogonium; B = Primary spermatocyte  
(iii) 'B' = Diploid E = Haploid  
(iv) 'F' = Sertoli cells – Nutrition to germ cells  
(v) Mitosis in Cell 'A', Meiosis in cell 'B'

## CHAPTER 4

---

# REPRODUCTIVE HEALTH

---

---

### POINTS TO REMEMBER

---

**Amniocentesis** : Diagnostic technique to detect genetic disorder in the foetus.

**Infertility** : Inability to produce children in spite of unprotected sexual cohabitation of a couple.

**Mortality** : Death rate (number of persons removed from a population by death) at a given time.

**Sterilization** : A permanent method of birth control through surgery in male or female.

**IUCD** : Intra Uterine Contraceptive Device

**RCH** : Reproductive and Child Health care

**STD** : Sexually Transmitted Disease

**CDRI** : Central Drug Research Institute

**MMR** : Maternal Mortality Rate

**MTP** : Medical Termination of Pregnancy

**VD** : Venereal Disease

**RTI** : Reproductive Tract Infection

**PID** : Pelvic Inflammatory Disease

**ART** : Assisted Reproductive Technologies

**IVF** : In Vitro Fertilisation

**ZIFT** : Zygote Intra Fallopian Transfer

#### **Reasons for Infertility**

- (i) Physical
- (ii) Congenital diseases
- (iii) Drugs
- (iv) Immunological reaction

The couple can be assisted to have children through certain special techniques commonly known as assisted reproductive technologies (ART).



- (i) **In Vitro Fertilisation (IVF)** : Fertilization outside the body in almost similar conditions as that in the body, followed by embryo transfer (E.T.).

**Test Tube baby Programme** : Ova from the wife/donor female and sperm from husband/donor male are allowed to fuse under simulated condition in the laboratory.

**ZIFT** : Zygote intra fallopian transfer – Zygote or early embryo upto **Eight blastomeres** is transferred into the fallopian tube.

**IUT** : Intra Uterine Transfer – Embryo with **more than eight blasomeres** are transferred.

- (ii) **Gamete intra fallopian transfer (GIFT)** : Transfer of an ovum collected from a donor to fallopian tube of another female who can not produce ova, but can provide suitable conditions for fertilization and further development of the foetus upto parturition,
- (iii) **Intra Cytoplasmic sperm injection (ICSI)** : The sperm is directly injected into the ovum to form an embryo in the laboratory and then embryo transfer is carried out.
- (iv) **Artificial Insemination** : This method is used in cases where infertility is due to the inability of the male partner to inseminate the female or due to very low sperm counts in the ejaculates. In this method, the semen collected from the husband or a healthy donor is artificially introduced into the vagina or into the uterus (IUI-Intra uterine insemination).

### Method of Birth Control

- |                                |  |
|--------------------------------|--|
| (i) Natural Methods :          | Periodic abstinence<br>Coitus interrupts<br>Lactational amenorrhea.  |
| (ii) Barrier methods :         | Condom, Diaphragms, Cervical cap.  |
| (iii) Intra uterine devices :  | Non – medicated <i>e.g.</i> Lippes loop<br>Copper releasing <i>e.g.</i> , Cu-T<br>Hormone releasing <i>e.g.</i> LNG–20 |
| (iv) Oral contraceptives :     | Pills / Saheli<br>Small doses of either progestogens or<br>Progestogen – estrogen combination                          |
| (v) Surgical (Sterilisation) : | (1) Tubectomy; (2) Vasectomy   |

---

## QUESTIONS

### VSA (I MARK)

1. Give the term for prenatal diagnostic technique aimed to know the sex of developing foetus and to detect congenital disorders.
2. After a successful in vitro fertilisation, the fertilised egg begins to divide. Where is this egg transferred before it reaches the 8-celled stage and what is this technique called?

3. Give the term for rapid population growth.
4. Name the fluid from which foetal cells are extracted for chromosomal analysis.
5. Give technical name of female used to bring up in vitro fertilized egg to maturity.

### **SA – II (2 MARKS)**

6. Lactational Amenorrhea is a method of contraception Justify. What is the maximum effectiveness of this method in terms of period/duration?
7. How are non medicated IUD'S different from hormone releasing IUD'S. Give examples.
8. What are implants? How do they help in preventing fertilisation?
9. Briefly explain two natural barriers for birth control.
10. Enlist any four possible reasons of infertility in human beings.

### **SA – I (3 MARKS)**

11. Give another name for sexually transmitted diseases. Name two sexually transmitted diseases which are curable and two diseases which are not curable.
12. Differentiate between Vasectomy and Tubectomy.
13. Name the techniques which are employed in following cases :
  - (a) Transfer of an ovum collected from a donor into the fallopian tube of another female who cannot produce ova but can provide suitable environment for fertilisation and development.
  - (b) Embryo is formed in laboratory in which sperm is directly injected into ovum.
  - (c) Semen collected either from husband or a healthy donor is artificially introduced either into vagina or uterus.
14. Mention the various precautions one has to take in order to protect himself/herself from STDs.

### **LA (5 MARKS)**

15. Briefly explain the various reproductive technologies to assist an infertile couple to have children.

## **ANSWERS**

---

### **VSA (1 MARKS)**

1. Amniocentesis.
2. Fallopian tube; Zygote intra fallopian transfer (ZIFT)
3. Population explosion.

4. Amniotic fluid.
5. Surrogate mother.

**SA - II (2 MARKS)**

6. (a) Ovulation and menstrual cycle do not occur during the period of intense lactation following parturition. Therefore, as the mother breast feeds, chances of conception are nil.  
(b) It is effective only upto a maximum period of six months following parturition.
7. (a) Non medicated IUDs = Lippes loop, Copper releasing IUDS ( CuT, Multiload 375) → These increase phagocytosis of sperms within uterus and release copper ions which suppress sperm motility and fertilising capacity of sperm.  
(b) Hormone releasing IUDs – Progestasert, LNG–20 – These makes uterus unsuitable for implantation and the cervix hostile to sperms.
8. The structures which contain hormones like progesterone and estrogen and are placed under the skin.
9. Periodic abstinence – couple should avoid coitus from 10th to 17th day of menstrual cycle.  
Coitus interruptus – Male partner withdraws his penis from the vagina just before ejaculation of semen.
10. Physical, congenital disease, Drugs, Immunological and even psychological (any four).

**SA - I (3 MARKS)**

11. Venereal disease (VD)/Reproductive tract infection (RTI)  
Curable–Syphilis, Gonorrhoea  
Non Curable – Hepatitis B, AIDS
- 12.

<i>Vasectomy</i>	<i>Tubectomy</i>
<ol style="list-style-type: none"> <li>1. Method of sterilisation in males</li> <li>2. Vasa defferentia of both sides are cut and tied</li> <li>3. Prevents movement of sperms at cut end.</li> </ol>	<ol style="list-style-type: none"> <li>1. Method of sterilisation in females.</li> <li>2. Fallopian tube of both sides are cut and tied.</li> <li>3. Prevent movement of egg at cut end.</li> </ol>

13. (a) Gamete intra fallopian transfer.  
(b) Intra cytoplasmic sperm injection  
(c) Intra uterine insemination.

14. (i) Avoid blood transfusion from an infected person.  
(ii) Avoid sex with an unknown partner and multiple partners.  
(iii) Always use condom.  
(iv) Avoid sharing of injections needles and syringes and surgical instruments.

**LA (5 MARKS)**

15. Refer page no. 64 NCERT book./Points to remember in this chapter.

## CHAPTER 5

---

# PRINCIPLES OF INHERITANCE AND VARIATION

---

---

### POINTS TO REMEMBER

---

**Allele** : Various or slightly different forms of a gene, having same position on chromosomes.

**Phenotype** : The observable or external characteristics of an organism

**Genotype** : The genetic constitution of an organism.

**Monohybrid cross** : A cross between two individuals of species, considering the inheritance of single pair of contrasting character *e.g.*, a cross between pure tall (TT) and Dwarf (tt).

**Dihybrid cross** : A cross between two individuals of a species, considering the inheritance of two pairs of contrasting traits/characters *e.g.*, a cross between Round and Yellow (RRYY) and wrinkled and green (rryy).

**Incomplete dominance** : When one of the two alleles of a gene is incompletely dominant over the other allele.

**Co dominance** : When two alleles of a gene are equally dominant and express themselves even when they are together.

**Multiple allelism** : When a gene exists in more than two allelic forms *e.g.*, gene for blood group exist in three allelic forms,  $I^A$ ,  $I^B$  and  $i$ .

**Aneuploidy** : The phenomenon of gain or loss of one or more chromosome(s), that results due to failure of separation of homologous pair of chromosomes during meiosis.

**Trisomy** : The condition in which a particular chromosome is present in three copies in a diploid cell/nucleus.

**Male heterogamety** : When male produces two different types of gametes/sperms *e.g.*, In human beings X and Y.

**Mutation** : The sudden heritable change in the base sequence of DNA, or structure of chromosome or a change in the number of chromosomes.

**Pedigree Analysis** : The analysis of the distribution and movement of trait in a series of generations of a family.

**Female Heterogamety** : When female produces two different types of gametes/ova *e.g.*, female bird produces Z and W gametes.

**Law of Dominance** : When two individuals of a species differing in a pair of contrasting characters/traits are crossed, the trait that appears in the F<sub>1</sub> hybrid is dominant and the alternate form that remains hidden, is called recessive.

**Law of Segregation** : The members of allelic pair that remained together in the parent, Segregate/separate during gamete formation and only one of the factors enters a gamete.

**Law of Independent Assortment** : In the inheritance of two pairs of contrasting characters, the factors of each pair of characters segregate independently of the factors of the other pair of characters.

**Test Cross** : When offspring or individual with dominant phenotype, whose genotype is not known, is crossed with an individual who is homozygous recessive for the trait.

The progeny of monohybrid test cross ratio is 1 : 1 while the dihybrid test cross ratio is 1 : 1 : 1 : 1.

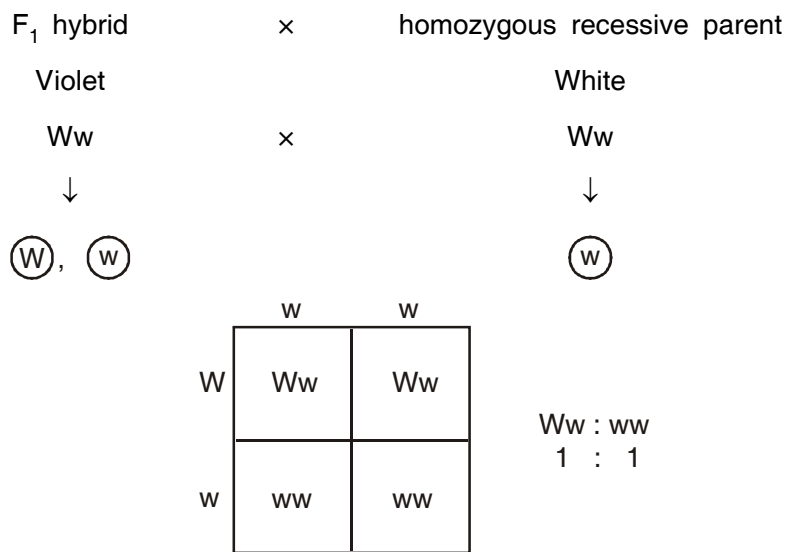

**Use of Test Cross** : The test cross is used to find the genotype of an organism.

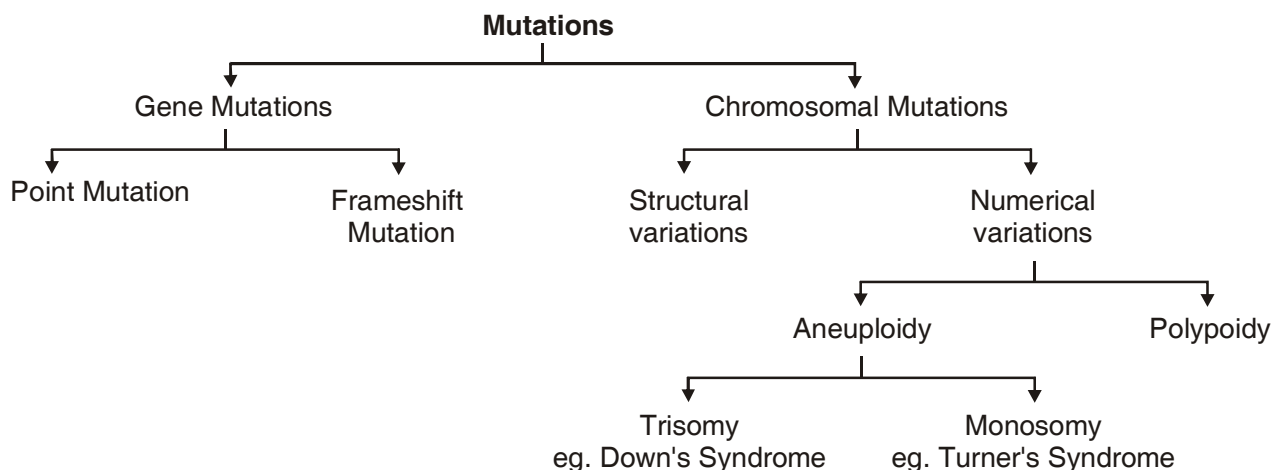

**Incomplete dominance** : It is the phenomenon where none of the two contrasting alleles is dominant but express themselves partially when present together in a hybrid and somewhat intermediate.

Example : *Antirrhinum majus* (Snapdragon)

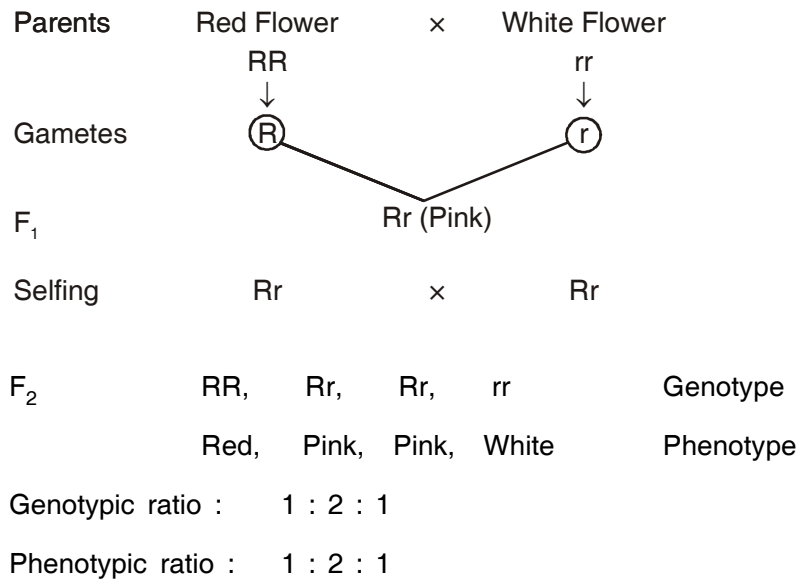

**Co-dominance** : The alleles which do not show dominance recessive relationship and are able to express themselves independently when present together are called co-dominant alleles and this phenomenon is known as co-dominance. *Example* : Human blood groups.

<i>Blood Group</i>	<i>Genotype</i>
A	I <sup>A</sup> I <sup>A</sup> , I <sup>A</sup> i
B	I <sup>B</sup> I <sup>B</sup> , I <sup>B</sup> i
AB	I <sup>A</sup> I <sup>B</sup>
O	ii

In human blood, there are six genotype and four phenotypes.

## QUESTIONS

### VSA (I MARK)

1. Give any two reasons for the selection of pea plants by Mendel for his experiments.
2. Name any one plant that shows the phenomenon of incomplete dominance during the inheritance of its flower colour.
3. Name the base change and the amino acid change, responsible for sickle cell anaemia.
4. Name the disorder with the following chromosome complement.
  - (i) 22 pairs of autosomes + X X Y
  - (ii) 22 pairs of autosomes + 21st chromosome + XY.

5. A haemophilic man marries a normal homozygous woman. What is the probability that their daughter will be haemophilic?
6. A test is performed to know whether the given plant is homozygous dominant or heterozygous. Name the test and phenotypic ratio of this test for a monohybrid cross.

### SA - II (2 MARKS)

7. Identify the sex of organism as male or female in which the sex chromosome are found as (i) ZW in bird (ii) XY in *Drosophila* (iii) ZZ in birds. (iv) XO in grasshopper.
8. Mention two differences between Turner's syndrome and Klinefelter's syndrome.
9. The human male never passes on the gene for haemophilia to his son. Why is it so?
10. Mention four reasons why *Drosophila* was chosen by Morgan for his experiments in genetics.
11. Differentiate between point mutation and frameshift mutations.

### SA-I (3 MARKS)

12. A woman with O blood group marries a man with AB blood group
  - (i) work out all the possible phenotypes and genotypes of the progeny.
  - (ii) Discuss the kind of dominance in the parents and the progeny in this case.
13. Explain the cause of Klinefelter's syndrome. Give any four symptoms shown by sufferer of this syndrome.
14. In Mendel's breeding experiment on garden pea, the offspring of F<sub>2</sub> generation are obtained in the ratio of 25% pure yellow pod, 50% hybrid green pods and 25% green pods State (i) which pod colour is dominant (ii) The Phenotypes of the individuals of F<sub>1</sub> generation. (iii) Workout the cross.

### LA (5 MARKS)

15. A dihybrid heterozygous round, yellow seeded garden pea (*Pisum sativum*) was crossed with a double recessive plant.
  - (i) What type of cross is this?
  - (ii) Work out the genotype and phenotype of the progeny.
  - (iii) What principle of Mendel is illustrated through the result of this cross?

## ANSWERS

---

### VSA (1 MARK)

1. (i) Many varieties with contrasting forms of characters



- (ii) Can easily be cross pollinated as well as self pollinated.
- 2. Dog flower (Snapdragon or *Antirrhinum* sp.)
- 3. GAG changes GUG, Glutamic acid is substituted by valine.
- 4. (i) Klinefetter's Syndrome (ii) Down's syndrome
- 5. Their daughter can never be haemophilic. (0%).
- 6. Test cross 1 : 1.

### SA – II (2 MARKS)

- 7. (i) Female; (ii) Male; (iii) Female (iv) Male
- 8. **Turner's Syndrome** : The individual is female and it has 45 chromosomes *i.e.*, one X chromosome is less.  
**Klinefelter's Syndrome** : The individual is male and has 47 chromosomes *i.e.*, one extra X chromosome.
- 9. The gene for haemophilia is present on X chromosome. A male has only one X chromosome which he receives from his mother and Y chromosome from father. The human male passes the X chromosome to his daughters but not to the male progeny (sons).
- 10. (i) Very short life cycle (2-weeks)  
(ii) Can be grown easily in laboratory  
(iii) In single mating produce a large no. of flies.  
(iv) Male and female show many hereditary variations  
(v) It has only 4 pairs of chromosomes which are distinct in size and Shape.
- 11. **Point Mutations** : Arises due to change in a single base pair of DNA *e.g.*, sickle cell anaemia.  
**Frame shift mutations** : Deletion or insertion/duplication/addition of one or two bases in DNA.

### SA – I (3 MARKS)

- 12. (i) Blood group AB has alleles as  $I^A$ ,  $I^B$  and O group has  $i$  which on cross gives the both blood groups A and B while the genotype of progeny will be  $I^A i$  and  $I^B i$ .  
(ii)  $I^A$  and  $I^B$  are equally dominant (co-dominant). In multiple allelism, the gene I exists in 3 allelic forms,  $I^A$ ,  $I^B$  and  $i$ .
- 13. **Cause** : Presence of an extra chromosome in male *i.e.*, XXY.  
**Symptoms** : Development of breast, Female type pubic hair pattern, poor beard growth, under developed testes and tall stature with feminised physique.
- 14. (i) Green pod colour is dominant

(ii) Green pod colour

(iii) Parents GG(green) X gg (yellow)

Gametes (G) (g)

F1 generation Gg (Hybrid green)

Gametes (G) (g) X (G) (g)

F<sub>2</sub> generation GG Gg Gg gg

Phenotypic ratio 3 : 1

Genotypic ratio 1 : 2 : 1

**LA (5 MARKS)**

15. (i) It is a dihybrid test cross

(ii) Parent RrYy (Round Yellow) rryy (Wrinkled green)

Gametes (RY), (Ry), (rY), (rY) X (ry)

Gametes		RY	Ry	rY	ry
F <sub>1</sub> progeny	ry	RrYy Round, Yellow	Rryy Round and green	rrYy wrinkled, yellow	rryy wrinkled, green.

Phenotypic ratio : 1 : 1 : 1 : 1

Genotypic ratio : 1 : 1 : 1 : 1

(iii) It illustrates the Principle of independent assortment.

## CHAPTER 6

---

# MOLECULAR BASIS OF INHERITANCE

---

---

### POINTS TO REMEMBER

---

**Anticodon** : A sequence of three nitrogenous bases on t RNA which is complementary to the codon on mRNA.

**Transformation** : The phenomenon by which the DNA isolated from one type of a cell, when introduced into another type, is able to express some of the properties of the former into the latter.

**Transcription** : The process of copying genetic information from one strand of DNA into RNA.

**Translation** : The process of polymerisation of amino-acids to form a polypeptide as dictated by mRNA.

**Nucleosome** : The structure formed when negatively charged DNA is wrapped around positively charged histone octamer.

**DNA Polymorphism** : The variations at genetic level, where an inheritable mutation is observed.

**Satellite DNA** : The repetitive DNA sequences which form a large portion of genome and have high degree of polymorphism but do not code for any proteins.

**Operon** : A group of genes which control a metabolic pathway.

**Exons** : The regions of a gene which become part of mRNA and code for different regions of proteins.

**Introns** : The regions of a gene which are removed during the processing of mRNA.

**Euchromatin** : The region of chromatin which is loosely packed and transcriptionally active.

**Heterochromatin** : The chromatin that is more densely packed, stains dark and is transcriptionally inactive.

**Capping** : Adding of methyl guanosine triphosphate to the 5' end of hnRNA.

**Splicing** : The process in eukaryotic genes in which introns are removed and the exons are joined together to form mRNA.

**Central Dogma** : Replication



**Replication fork** : The Y shaped structure formed when double stranded DNA is unwound upto a point during its replication.

**VNTR** : Variable Number Tandem Repeats

**YAC** : Yeast Artificial Chromosome

**BAC** : Bacterial Artificial Chromosome

**SNPs** : Single Nucleotide polymorphism

**HGP** : Human Genome Project

**hnRNA** : Heterogenous nuclear RNA. It is precursor of mRNA.

**Chemical Structure of Polynucleotide Chain (DNA/RNA)** : A nucleotide has three components—

1. **Nitrogen base**

(i) *Purines* : Adenine and Guanine

(ii) *Pyrimidines* : Cytosine, Thymine and Uracil

Thymine in DNA and Uracil in RNA.

2. **Pentose Sugar** : Ribose (in RNA) or Deoxyribose (in DNA).

3. **Phosphate Group**

☐ Nitrogen base is linked to pentose sugar through N-glycosidic linkage.

Nitrogen base + Sugar = Nucleoside

☐ Phosphate group is linked to 5'-OH of a nucleoside through phosphoester linkage.

Nucleoside + Phosphate group = Nucleotide.

☐ Two nucleotides are linked through 3'-5' phosphodiester linkage to form a dinucleotide

☐ A polynucleotide chain has free phosphate group at 5'-end of ribose sugar and 3'-OH group at other end.

*RNA is highly reactive than DNA* : In RNA nucleotide has an additional -OH group at 2'-position in the ribose.

**Double-helix Structure of DNA** : Proposed by Watson and Crick in 1953.

(i) DNA is made up of two polynucleotide chains.

(ii) The backbone is made up of sugar and phosphate and the bases project inside.

(iii) Both polynucleotide chains are antiparallel i.e. one chain has polarity 5'-3' and other chain has 3'-5'.

(iv) These two strands of chains are held together by hydrogen bonds i.e. A==T, C≡≡G.

(v) Both chains are coiled in right handed fashion. The pitch of helix is 3.4 nm with 10 bp.

**Hershey and Chase Experiment** : In 1952, Hershey and Chase performed an experiment on bacteriophages (Viruses that infect bacteria) and proved that DNA is the genetic material.

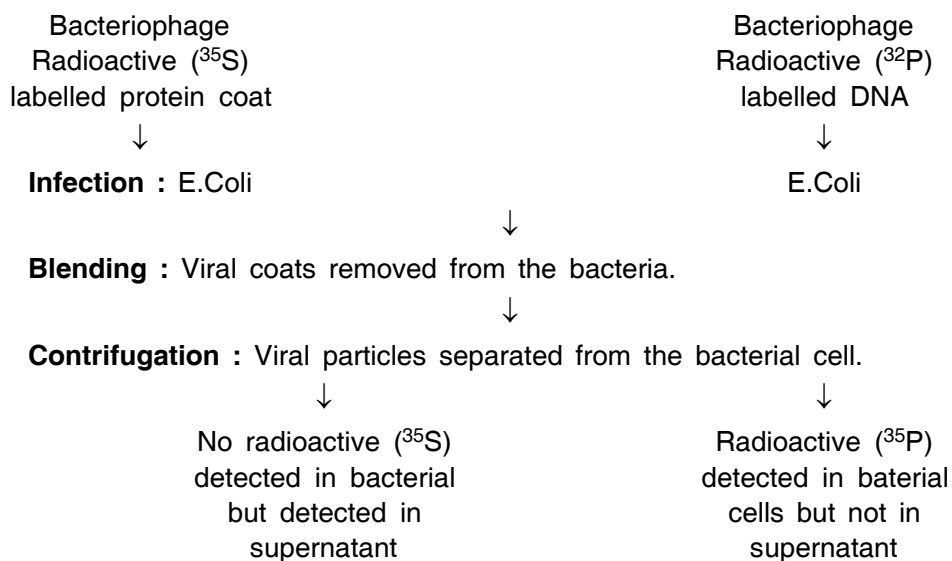

**Conclusion** : DNA is the genetic material.

#### Meselson and Stahl's Experiment :

- ❑ Meselson and Stahl performed the experiment in 1958 on *E.coli* to prove that DNA replication is semiconservative.
- ❑ *E.coli* was grown in  $^{15}\text{NH}_4\text{Cl}$  for many generations.
- ❑  $^{15}\text{N}$  was incorporated into newly synthesised DNA.
- ❑ This heavy DNA could be differentiated from normal DNA by centrifugation in coesium Chloride ( $\text{CsCl}$ ) density gradient.
- ❑ Then they transferred these *E.coli* into a medium with normal  $^{14}\text{NH}_4\text{Cl}$ .
- ❑ After 20 minutes, it was found that all the DNA molecules of daughter cells were hybrid—First generation.
- ❑ After 40 minutes, it was found that 50% DNA molecules were hybrid and 50% were normal.

**Transcription in Prokaryotes** : In prokaryotes the process of transcription is completed in three steps:

1. **Initiation** : RNA polymerase binds with initiation factor (sigma factor) and then binds to promotor site.
2. **Elongation** : RNA polymerase separates from sigma factor and adds nucleoside triphosphate as substrate. RNA is formed during the process and remains bound to enzyme RNA polymerase.
3. **Termination** : On reaching terminator region RNA polymerase binds with rho factor (terminator factor). As a result nascent RNA separates.

#### Transcription in Eukaryotes :

- ❑ In eukaryotes three types of RNA polymerases found in the nucleus (apart from RNA polymerases are found in the organelles) are involved in transcription.

**RNA Polymerase I** : Transcribes rRNAs.

**RNA Polymerase II** : Transcribes hnRNA (which is precursor of mRNA).

**RNA Polymerase III** : Transcribes tRNA, 5 srRNA and snRNA.

- ❑ The primary transcript has both exon and intron regions.
- ❑ Introns which are non-coding regions removed by a process called splicing.
- ❑ hnRNA undergoes two additional processes :
  - (a) *Capping* : An unusual nucleotide (methylguanosine triphosphate) is added to 5'-end of hnRNA.
  - (b) *Tailing* : Adenylate residues (200-300) are added at 3'-end.

It is fully processed hnRNA, now called mRNA.

### Lac Operon

- ❑ The concept of operon was proposed by Jacob Monod. Operon is a unit of prokaryotic gene expression.
- ❑ The lac operon consists of one regulatory gene (the i-gene) and three structural genes (z, y and a).
- ❑ The i-gene codes for repressor of lac operon.
- ❑ Lactose is an inducer.
- ❑ Gene Z - Codes for  $\beta$ -galactosidase  
Gene Y - Codes for permease  
Gene A - Codes for transacetylase.

#### In the absence of Inducer (lactose)

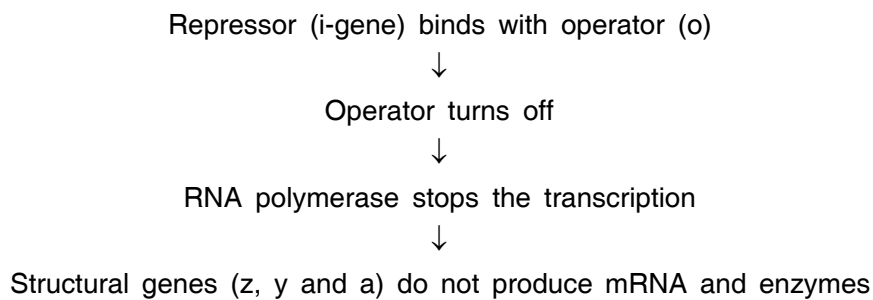

#### In the presence of Inducer (lactose)

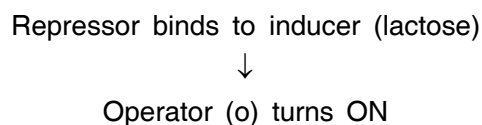

↓  
 RNA polymerase starts the transcription  
 ↓  
 Structural genes (z, y and a) produce mRNA and enzymes  
 ( $\beta$ -galactosidase, permease and transacetylase respectively)

## QUESTIONS

### VSA (I MARK)

1. Name the factors for RNA polymerase enzyme which recognises the start and termination signals on DNA for transcription process in Bacteria.
2. Mention the function of non-histone protein.
3. During translation what role is performed by tRNA
4. RNA viruses mutate and evolve faster than other viruses. Why?
5. Name the parts 'X' and 'Y' of the transcription unit given below.

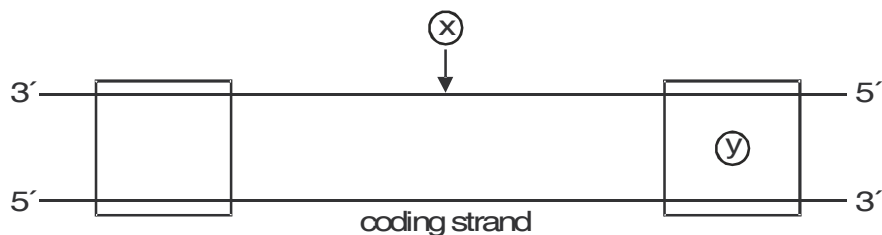

6. Mention the dual functions of AUG.
7. Write the segment of RNA transcribed from the given DNA –  
 3' – A T G C A G T A C G T C G T A – 5' – Template Strand  
 5' – T A C G T C A T G C A G C A T – 3' – Coding Strand.

### SA – II (2 MARKS)

8. The process of termination during transcription in a prokaryotic cell is being represented here. Name the label a, b, c and d.

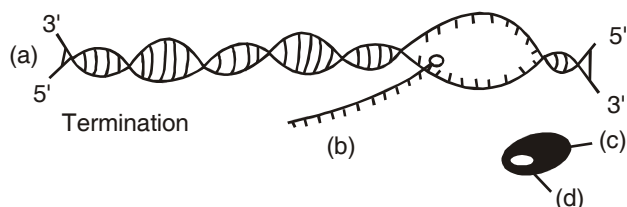

9. Complete the blanks a, b, c and d on the basis of Frederick Griffith Experiment.
- S Strain → inject into mice → (a)
- R strain → inject into mice → (b)
- S strain (heat killed) → inject into mice → (c)
- S strain (heat killed) + R strain (live) → inject into mice → (d)
10. Give two reasons why both the strands of DNA are not copied during transcription.
11. Mention any two applications of DNA fingerprinting.
12. State the 4 criteria which a molecule must fulfill to act as a genetic material.

### SA - I (3 MARKS)

13. Give six points of difference between DNA and RNA in their structure/chemistry and function.
14. Explain how does the hnRNA becomes the mRNA.

### OR

Explain the process of splicing, capping and tailing which occur during transcription in Eukaryotes.

15. Name the three major types of RNAs, specifying the function of each in the synthesis of Polypeptide.
16. Enlist the goals of Human genome project.
17. A tRNA is charged with the aminoacids methionine.
- (i) Give the anti-codon of this tRNA.
- (ii) Write the Codon for methionine.
- (iii) Name the enzyme responsible for binding of aminoacid to tRNA.
18. Illustrate schematically the process of initiation, elongation and termination during transcription of a gene in a bacterium.

### LA (5 MARKS)

19. What is meant by semi conservative replication? How did Meselson and Stahl prove it experimentally?
20. What does the *lac* operon consist of? How is the operator switch turned on and off in the expression of genes in this operon? Explain.
21. State Salient features of genetic code.
22. Describe the process of transcription of mRNA in an eukaryotic cell.
23. Describe the various steps involved in the technique of DNA fingerprinting.



## ANSWERS

---

### VSA (I MARK)

1. Sigma ( $\sigma$ ) factor and Rho( $\rho$ ) factor
2. Packaging of chromatin
3. (i) Structural role  
(ii) Transfer of amino acid.
4. -OH group is present on RNA, which is a reactive group so it is unstable and mutates faster.
5. X – Template strand, Y – Terminator.
6. (i) Acts as initiation codon for protein synthesis  
(ii) It codes for methionine.
7. 5' – U A C G U C A U G C A G C A U – 3' (In RNA 'T' is replaced by 'U')

### SA – II (2 MARKS)

8. (a) DNA molecule  
(b) mRNA transcript  
(c) RNA polymers  
(d) Rho factor
9. (a) Mice die  
(b) mice live  
(c) mice live  
(d) mice die
10. (a) If both the strands of DNA are copied, two different RNAs (complementary to each other) and hence two different polypeptides; if a segment of DNA produces two polypeptides, the genetic information machinery becomes complicated.  
(b) The two complementary RNA molecules (produced simultaneously) would form a double-stranded RNA rather than getting translated into polypeptides.  
(c) RNA polymerase carries out polymerisation in 5' – 3' direction and hence the DNA strand with 3' – 5' polarity acts as the template strand. **(Any two)**
11. (i) To identify criminals in the forensic laboratory.  
(ii) To determine the real or biological parents in case of disputes.  
(iii) To identify racial groups to rewrite the biological evolution. **(Any two)**

12. (i) It should be able to generate its replica.  
(ii) Should be chemically and structurally stable.  
(iii) Should be able to express itself in the form of Mendelian characters.  
(iv) Should provide the scope for slow changes (mutations) that are necessary for evolution.

### SA - I (3 MARKS)

13.

DNA	RNA
(i) Double stranded molecules	(i) Single stranded molecules
(ii) Thymine as pyrimidine base	(ii) Uracil as pyrimidine base
(iii) Pentose sugar is Deoxyribose	(iii) Sugar is Ribose
(iv) Quite stable and not very reactive	(iv) 2'-OH makes it reactive
(v) Dictates the synthesis of Polypeptides	(v) Perform other functions in protein synthesis.
(vi) Found in the nucleus.	(vi) They are transported into the cytoplasm.

14. hnRNA is precursor of mRNA. It undergoes

- (i) **Splicing** : Introns are removed and exons are joined together.  
(ii) **Capping** : an unusual nucleotide (methyl guanosine triphosphate) is added to the 5' end of hnRNA.  
(iii) Adenylate residues (200-300) are added at 3' end of hnRNA.

Refer fig. 6.11, page 110, NCERT book. Biology - XII

15. (i) **mRNA-(Messenger RNA)** : decides the sequence of amino acids.  
(ii) **tRNA-(Transfer RNA)** : (a) Recognises the codon on mRNA (b) transport the amino acid to the site of protein synthesis.  
(iii) **rRNA (Ribosomal RNA)** : Plays the structural and catalytic role during translation.

17. Refer points given on page 118, NCERT Biology XII.

17. (a) UAC                      (b) AUG                      (c) Amino-acyl-tRNA synthetase.

18. Refer figure 6.10, page 109, NCERT Biology XII.

### LA (5 MARKS)

19. Meselson and Stahl, performed an experiment using *E.Coli* to prove that DNA replication is semi conservative.

- They grew *E. Coli* in a medium containing  $^{15}\text{NH}_4\text{Cl}$ .

- Then separated heavy DNA from normal ( $^{14}\text{N}$ ) by centrifugation in CsCl density gradient.
  - The DNA extracted, after one generation of transfer from  $^{15}\text{N}$  medium to  $^{14}\text{N}$  medium, had an intermediate density.
  - The DNA extracted after two generations consisted of equal amounts of light and hybrid DNA.
  - They proved that DNA replicates in a semiconservative manner. (Refer figure 6.7, page 105, NCERT Biology XII).
20. *Lac Operon* consists of the following :
- **Structural genes** : z, y, a which transcribe a polycistronic mRNA.
  - gene 'z' codes for  $\beta$ -galactosidase
  - gene 'y' codes for permease.
  - gene 'a' codes for transacetylase.
  - **Promotor** : The site where RNA polymerase binds for transcription.
  - **Operator** : acts as a switch for the operon
  - **Repressor** : It binds to the operator and prevents the RNA Polymerase from transcribing.
  - **Inducer** : Lactose is the inducer that inactivates the repressor by binding to it.
  - Allows an access for the RNA polymerase to the structural gene and transcription.
  - Refer figure 6.14, page 117, NCERT, Biology XII.
21. Refer page 112, NCERT Biology XII.
22. Refer to Ans. 35 and figure 6.11, page 110, NCERT Biology XII.
23. Steps/procedure in DNA fingerprinting –
- Extraction of DNA - using high speed refrigerated centrifuge.
  - Amplification - many copies are made using PCR
  - Restriction Digestion - using restriction enzymes DNA is cut into fragments.
  - Separation of DNA fragments - using electrophoresis-agarose polymer gel.
  - Southern Blotting : Separated DNA sequences are transferred onto nitrocellulose or nylon membrane.
  - Hybridisation : The nylon membrane exposed to radio active probes.
  - Autoradiography : The dark bands develop at the probe site.

## CHAPTER 7

---

# EVOLUTION

---

---

### POINTS TO REMEMBER

---

**Artificial Selection** : It is the process carried out by man to select better breeds of plants and animals.

**Bio-geography** : The study of patterns of distribution of plants and animals in different parts of earth.

**Founders Effect** : A genetic drift in human population where a population in a new settlement have different gene frequency from that of the parents population. The original drifted population said to be founder.

**Gene Pool** : Sum total of all the genes in a population.

**Genetic Drift** : Chance elimination of genes of certain traits from a population due to migration or death.

**Panspermia** : units of life in the form of so called spores, which were transferred to earth from outer space, as believed by some scientists.

**Saltation** : Single step large mutations.

**Speciation** : It is the formation of new species from the pre-existing ones.

**Organic (Biological) Evolution** : Changes in the property of organisms or groups of such populations over a number of generations.

**Homologous organs** : These have same basic structure and embryonic origin but perform different functions in different species.

**Analogous organs** : These organs are different in their basic structure and embryonic origin but perform similar functions.

**Human Evolution** : *Ramapithecus* → *Australopithecus* → *Homo habilis* → *Homo erectus* → *Homo sapiens* → *Homo sapiens sapiens*.

#### The Theories of Origin of Life

1. **Theory of Special Creation** : According to this theory God has created life within 6 days.
2. **Theory of Spontaneous Generation** : According to this theory life originated from decaying and rotting matter like straw and mud.

3. **Panspermiaic Theory** : According to this theory life come from space in the form of spores called 'Panspermia'.
4. **Modern Theory or Oparin-Haldane Theory** : According to this theory life originated upon earth spontaneously from non-living matter. First inorganic compounds then organic compounds were formed in accordance with ever changing environmental conditions. This is called chemical evolution. The conditions on earth were – high temperature volcanic storms, reducing atmosphere (without free oxygen) containing methane and ammonia.

**Experimental Evidence for Abogenesis (Miller's Experiment)** : Stanley Miller in 1953 demonstrated in a laboratory that electric discharges can produce complex organic compounds from a mixture of methane, ammonia, water vapours and hydrogen. In his experiment he found that simple organic compounds including some amino acids are formed. In similar experiments others observed the formation of sugar, nitrogen bases, fats and pigments.

**Divergent evolution** : It shows relationship of structures having same origin but perform different functions. It is called homology. *Examples* : (i) Wings of a bird, forelimbs of horse, flippers of whale. (ii) Thorns of Bougainvillea and tendrils of cucurbita.

**Convergent evolution** : This shows the relationship of structures having functional similarities but different origin. It is called analogy. *Examples* : (i) Wings of insects and wings of bird. (ii) Sweet potato and potato.

**Industrial melanism** : It is an adaptation where moths living in the industrial area developed melanin pigments to match their body colour to the tree-trunk. Before Industrialisation in England, it was observed that there were more white-winged moths on trees than dark-winged moths (melanised moths). After industrialisation (in 1920), there were more dark-winged moths in some areas. After industrialisation, trees got covered by smoke. So white-winged moth were picked up by the birds but dark-winged moths were escaped and survived. Thus, industrial melanism supports the evolution by natural selection.

**Adaptive radiation** : The process of evolution of different species in a geographical area starting from a point and literally radiating to other habitats is called adaptive radiation. *Examples* : (i) Darwin's finches found in Galapagos island. (ii) Marsupials of Australia.

**Evolution of Plants** : Unicellular → Multicellular → Algae → Rhynia type plants → Cycads → Gnetales → Dicot → Monocot.

**Hardy-Weinberg Principle** : The allele frequencies in a population are stable and is constant from generation to generation. Sum total of all the allele frequencies is 1.

**Factors Affecting Hardy-Weinberg Equilibrium** : Gene migration, Genetic drift, Mutations, Recombination, Natural Selection.

**Some Facts :**

- The Universe is about twenty billions years old.
- Earth was formed about 4.5 billion years ago.
- Life started appearing about 4 billion years earlier.

## QUESTIONS

---

### VSA (I MARK)

1. Name one fish like reptile that evolved from land reptile about 200 million years ago?
2. For a long time, it was believed that life originated from decaying matter. What is this theory known as? Name the scientist who experimentally disproved this theory.
3. If abiotic origin of life is in progress on a planet other than earth, what should be the conditions there?
4. Name the person who proposed that population tends to increase geometrically while food production supply arithmetically.
5. Name the scientist who had also come to similar conclusion as that of Darwin about natural selection as a mechanism of evolution.

### SA – II (2 MARKS)

6. Explain Oparin-Haldane theory of chemical evolution of life.
7. Distinguish between convergent and divergent evolution giving one example of each.
8. What is adaptive radiation? Explain with an example.

### SA – I (3 MARKS)

9.
  - (i) State the Hardy-Weinberg principle.
  - (ii) When there is a disturbance in the Hardy-Weinberg equilibrium, what would it result in?
  - (iii) According to this principle, what is the sum total of all allelic frequencies?
10. Classify the following as examples of homology and analogy–
  - (i) Hearts of fish and crocodile
  - (ii) Wings of butterfly and birds
  - (iii) Eyes of Octopus and Mammals
  - (iv) Tubers of Potato and sweet potato
  - (v) Thorns of *Bougainvillea* and spines of *Opuntia*
  - (vi) Thorn of *Bougainvillea* and tendrils of cucurbits.
11. Stanley Miller and Harold Urey performed an experiment by recreating in the laboratory the probable conditions of the atmosphere of the primitive earth.
  - (i) What was the aim of the experiment?

- (ii) In what forms was the energy supplied for chemical reactions to occur?
- (III) For how long was the experiment run continuously? Name two products formed.
12. 'Industrial Melanism' in peppered moth is an excellent example of 'Natural selection'. Justify the statement.
13. Fill up the blanks left in the table showing Era, period and organism.

<i>Era</i>	<i>Period</i>	<i>Organisms</i>
Cenozoic	<u>a</u>	Modern man, Mammals, Birds, rise of monocot
<u>b</u>	Tertiary	Rise of first Primate, angiosperm
Mesozoic	<u>c</u>	Gingko, Gnetales
<u>d</u>	Jurassic	Conifers, cycads, Reptiles
Paleozoic	<u>e</u>	Early reptiles (extinct)
<u>f</u>	Silurian	Psilophyton

14. (i) In which part of the world, Neanderthal man lived?
- (ii) What was his brain's capacity?
- (iii) Mention the advancement which Neanderthal man showed over *Homo erectus*.
15. Figures given below are of Darwin's finches?



Variety of beaks of Darwin's finches.

- (a) Mention the specific geographical area where these were found.
- (b) Name and explain the phenomenon that has resulted in the evolution of such diverse species in the region.
- (c) How did Darwin visit the particular geographical area?

### LA (5 MARKS)

16. Is evolution a 'process' or the end result of a 'process'? Discuss. Describe various factors that effect Hardy-Weinberg equilibrium.

## ANSWERS

---

### VSA (I MARK)

1. *Ichthyosaurs*.
2. Theory of Spontaneous generation; Louis Pasteur.
3. Very high temperature, volcanic storms, Reducing atmosphere containing CH<sub>4</sub>, NH<sub>3</sub>, H<sub>2</sub> and water vapours.
4. Thomas Malthus.
5. Alfred Wallace.

### SA - II (2 MARKS)

6. The first life form could have come from the pre-existing, non-living organic molecules (like RNA, Proteins, etc.) and the formation of life was preceded by chemical evolution.
7. Refer page 130, 131, NCERT book, Biology - XII
8. Refer page 133, NCERT book, Biology - XII

### SA - I (3 MARKS)

9. (i) The allele frequency in a population are stable and constant from generation to generation.  
(ii) Evolution.  
(iii) One.
10. (i) Homology (ii) Analogy (iii) Analogy (iv) Analogy  
(v) Analogy (vi) Homology
11. (i) To prove Oparin's theory of origin of life.  
(ii) Electric discharge using electrodes.  
(iii) One week; Amino acids and Sugar.
12. Refer Page 131, NCERT book.
13. (a) Quaternary (b) Coenozoic (c) Cretaceous  
(d) Mesozoic (e) Carboniferous (f) Paleozoic
14. (i) Near Eastern and Central Asia  
(ii) 1400 c.c.  
(iii) More brain capacity, use of hides to cover body and burial of dead.



15. (a) Galapagos Island.  
(b) Adaptive radiation – Refer page 133, NCERT book.  
(c) Through sea voyage in a sail ship called H.M.S. Beagle.

**LA (5 MARKS)**

16. Refer page 135, NCERT book, Biology - XII

## CHAPTER 8

---

# HUMAN HEALTH AND DISEASE

---

---

### POINTS TO REMEMBER

---

**Carcinogens** : Cancer causing agents. *e.g.*, gamma rays. UV rays, dyes and lead.

**Immunity** : Resistance to infection or antigen.

**Immuno Suppressant** : The chemical which suppress the immunity response to antigen partially or completely.

**Interferon** : The glycoproteins produced by our body cells in response to a viral infection.

**Incubation Period** : The time period between infection and the appearance of symptoms.

**Metastasis** : The property in which the cancer cells spread to different sites through blood and develop secondary tumors.

**Oncogenes** : Viral genome which causes cancer.

**Retrovirus** : A virus having RNA as genetic material and forms DNA by reverse transcription and then replicate *e.g.*, Human Immunodeficiency Virus (HIV).

**Sporozoites** : The infective stage of protozoa *Plasmodium* which is injected into human blood through saliva of female *Anopheles* mosquito.

**Syndrome** : Collection of disease symptoms responsible for a disorder or a disease.

**Vaccination** : Inoculation of a vaccine to stimulate production of antibodies and provide immunity for one or more disease.

---

### ABBREVIATIONS

---

<b>PMNL</b>	:	Polymorpho-Nuclear Leukocytes
<b>CMI</b>	:	Cell Mediated Immunity
<b>ELISA</b>	:	Enzyme Linked Immunosorbent Assay
<b>HLA</b>	:	Human Leukocyte Antigen
<b>MALT</b>	:	Mucosal Associated Lymphoid Tissue
<b>SCID</b>	:	Severe Combined Immuno Deficiency
<b>NACO</b>	:	National AIDS Control Organisation
<b>MRI</b>	:	Magnetic Resonance Imaging

## FACTOR AFFECTING HEALTH

---

- (a) **Genetic** : Child may inherits certain disorders from parents.
- (b) **Life Style** : Water/food intake, rest, exercise, personal hygiene.
- (c) Infection and Corresponding immunity.

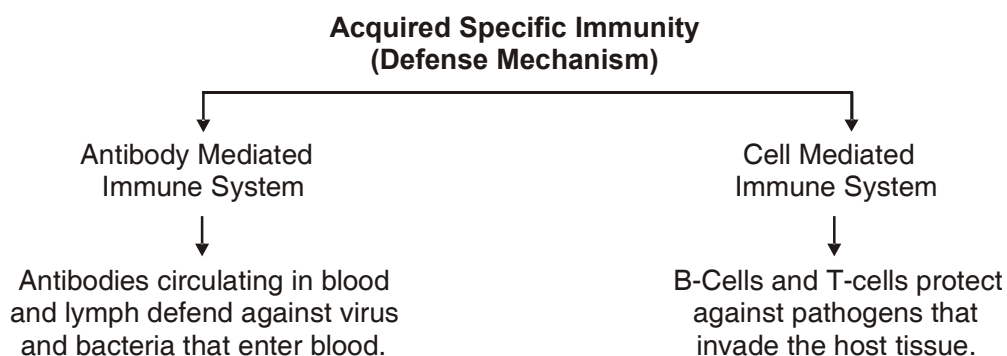

## PRODUCTION OF VACCINATION/IMMUNISATION

---

- ◆ It is based on the principle of memory and immunity.
- ◆ The antigenic preparations of proteins of pathogens or a solution of inactivated or weakened pathogens are introduced in the body.
- ◆ The antigenic properties are recognised.
- ◆ Cascade of reactions forms antibodies
- ◆ History of reactions is stored as memory.
- ◆ Subsequent exposures result in intensified response.

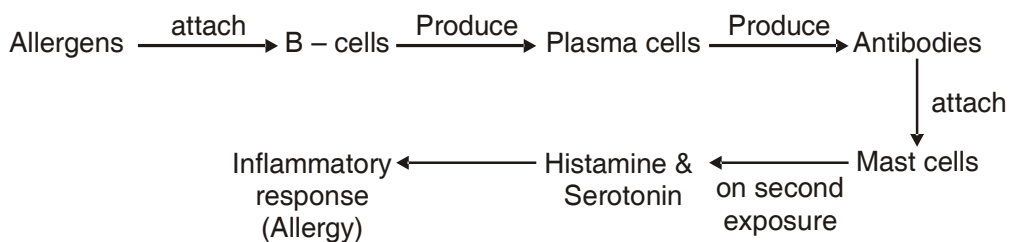

### Drugs

<i>Criteria</i>	<i>Opioids</i>	<i>Cannabinoids</i>	<i>Coca alkaloids</i>
Source	<i>Papaver somniferum</i> (Poppy Plant)	<i>Cannabis sativa</i> (Hemp Plant)	<i>Erythroxylum coca</i> (Coca plant)

Part of Plant	Fruits (Unripen Capsules)	Inflorescence, leaves, resin	Leaves and Young twigs
Product	Opium, Morphine Heroin/Smack	Charas, Ganja Hashish Marijuana	Cocaine (Coke/Crack)
Mode of Intake	Snorting, Injection	Oral, Inhalation	Snorting
Effects (Property)	Neuro depressant, Slow down the functions of the body	Interact with cannabinoid receptors, Cardiovascular system effects	Sense of euphoria interferes with neurotransmitters, Hallucination

## QUESTIONS

### VSA (I MARK)

- Name the diagnostic test which confirms typhoid.
- Name the two major groups of cells required to attain specific immunity.
- You have heard of many incidences of Chickengunya in our country. Name the vector of the disease.
- Breast fed babies are more immune to diseases than the bottle fed babies. Why?
- Name the pathogen which causes malignant malaria.
- Which microorganism is used to produce hepatitis B Vaccine?

### S.A. - II (2 MARKS)

- Where are B-cells and T-cells formed? How do they differ from each other?
- Given below are the pathogens and the diseases caused by them. Which out of these pairs is not correct matching pair and why?
 

(a) <i>Wuchereria</i>	–	Filariasis
(b) <i>Microsporium</i>	–	Ringworm
(c) <i>Salmonella</i>	–	Common Cold
(d) <i>Plasmodium</i>	–	Malaria
- What would happen to the immune system, if thymus gland is removed from the body of a person?
- Lymph nodes are secondary lymphoid organs. Describe the role of lymph nodes in our immune response.

### SA - I (3 MARKS)

- What are Cannabinoids? From which plant Cannabinoids are obtained? Which part of the body is affected by consuming these substances?

12. In the figure, structure of an antibody molecule is shown. Observe it and Give the answer of the following questions.

- (i) Label the parts A, B and C.
- (ii) Which cells produce these chemicals?
- (iii) State the function of these molecules.

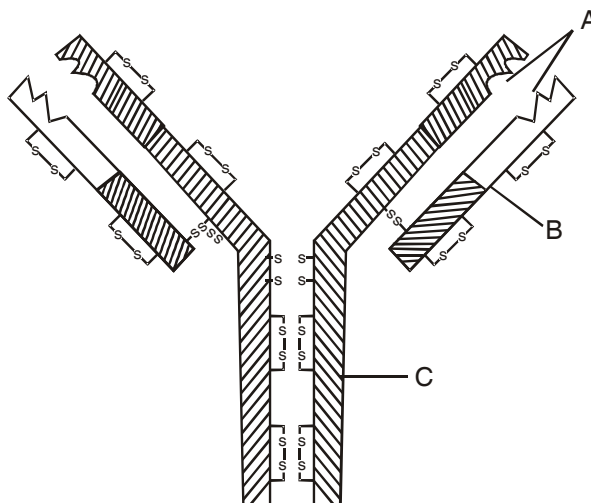

13. Mention any three causes of drug abuse. Suggest some measures for the prevention and control of drug abuse.

14. A person shows unwelcome immunogenic reactions while exposed to certain substances.

- (a) Name this condition.
- (b) What common term is given to the substances responsible for this condition?
- (c) Name the cells and the chemical substances released which cause such reactions.

15. Fill in the blanks in the different columns of the table given below to identify the nos 1 to 6.

<b>Name of disease</b>	<b>Causative organism</b>	<b>Symptoms</b>
1. Pneumonia	<i>Streptococcus</i>	(1)
2. Typhoid	(2)	High fever, weakness, headache, stomach pain
3. (3)	Rhinoviruses	Nasal Congestion, and discharge sorethroat cough, headache
4. Ascariasis	<i>Ascaris</i>	(4)
5. Ringworm	(5)	Dry, Scaly lesions on various body parts, Intense itching, redness.
6. (6)	<i>Entamoeba histolytica</i>	Constipation, cramps, abdominal pain, Stools with excess mucous and blood clots.

16. In the given flow diagram, the replication of retrovirus in a host cell is shown. Examine it and answer the following questions

- (a) Why is virus called retrovirus?
- (b) Fill in (1) and (2)
- (c) Can infected cell survive while viruses are being replicated and released by host cell?

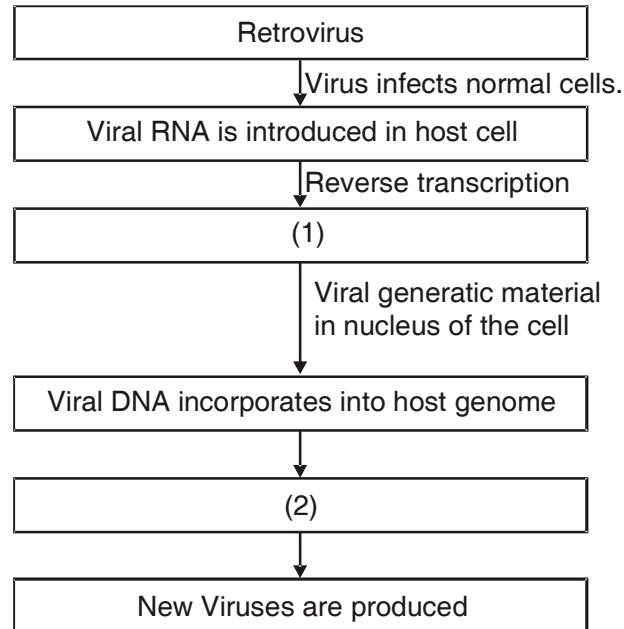

17. What is innate immunity? List the four types of barriers which protect the body from the entry of the foreign agents.

### LA (5 MARKS)

18. Answer the following with respect to Cancer.
- (a) How does a cancerous cell differ from a normal cell?
  - (b) Benign tumor is less dangerous than malignant tumor. Why?
  - (c) Describe causes of cancer.
  - (d) Mention two methods of treatment of the disease.
19. The pathogen of a disease depends on RBCs of human for growth and reproduction. The person with this pathogen suffers with chill and high fever.
- (a) Identify the disease.
  - (b) Name the pathogen.
  - (c) What is the cause of fever?
  - (d) Represent the life cycle of the pathogen diagrammatically.

20. The immune system of a person is suppressed. He was found positive for a pathogen in the diagnostic test ELISA.
- Name the disease, the patient is suffering from.
  - Which pathogen is identified by ELISA test?
  - Which cells of the body are attacked by the pathogen?
  - Suggest preventive measures of the infection.

---

## ANSWERS

---

### VAS (I MARK)

- Widal test
- B-lymphocytes and T-lymphocytes.
- Aedes* mosquitoes.
- The mother's milk consists of antibodies (IgA) such antibodies are not available to bottle fed babies.
- Plasmodium falciparum*.
- Yeast.

### SA - II (2 MARKS)

- B-cells and T-cells are formed in bone marrow. B-cells produce antibodies but T-cells do not produce antibodies but help B-cells to produce them.
- Salmonella* : Common cold is not a matching pair.  
*Salmonella* causes typhoid.
- T-lymphocytes are developed and matured in thymus gland. Immune system will become weak on removal of thymus gland.
- Lymph nodes provide the sites for interaction of lymphocytes with the antigen. When the microorganisms enter the lymph nodes, lymphocytes present there are activated and cause the immune response.

### SA - I (3 MARKS)

- ◆ Cannabinoids are a group of chemicals which interact with Cannabinoid receptors present
  - ◆ Principally in the brain Cannabinoids are obtained from the inflorescences of the plant *Cannabis sativa*.
  - ◆ The substances affect the cardiovascular system adversely.

12. (a) A-Antigen binding site B-Light chain  
 (b) B-lymphocytes.  
 (c) Heavy Chain  
 (d) Antibodies provide acquired immune response.
13. ♦ **Reasons to attract towards drug abuse** : Curiosity, peer pressure, escape from frustration and failure, family problems, false belief of enhanced performance.  
 ♦ **Preventive measures** :  
 – Avoid undue peer pressure  
 – Education and Counselling  
 – Seeking help from parents and peers.  
 – Looking for danger signs  
 – Seeking professional and medical help
14. (a) Allergy (b) Allergens  
 (c) Mast Cells – Histamine, Serotonin
15. (i) Alveoli filled with fluid, reduced breathing, fever, chills, cough and headache.  
 (ii) *Salmonella typhi*  
 (iii) Common Cold  
 (iv) Internal bleeding, muscular pain, anaemia, fever and blockage of the intestinal passage.  
 (v) *Microsporum species/Trichophyton species/Epidermophyton Species*.  
 (vi) Amoebiasis/amoebic dysentery
16. (a) HIV has RNA genome. It produces DNA by reverse transcription.  
 (b) 1 : Viral DNA is produced by reverse transcriptase.  
 2 : New Viral RNA is produced by the infected cell.  
 (c) Infected cell can survive.
17. Innate Immunity is non-specific type of defense that is present at the time of birth.  
 (i) **Physical Barriers** : Skin, mucous-coated epithelium or respiratory, digestive and urinogenital tract.  
 (ii) **Physiological Barriers** : Acidity of Stomach, lysozyme in saliva, tears, sweat.  
 (iii) **Cellular Barrier** : Macrophages, neutrophils, monocytes and natural killer lymphocytes.



- (iv) **Cytokine Barriers** : Interferons produced by Viral infected cells, protect the non-infected cells from further Viral infection.

**LA (5 MARKS)**

18. (a) In normal cells, growth and differentiation is highly controlled and regulated (contact inhibition). The cancerous cells have lost the property of contact inhibition, hence continue to divide giving rise to masses of cells (tumors).
- (b) The benign tumor remains confined in the organ affected as it is enclosed in a connective tissue sheath and does not enter the metastatic stage.
- (c) Cancer may be caused due to carcinogens which are physical (radiations), chemicals (Nicotine, Aflatoxin, Cadmium oxide, Asbestos) and biological (viral oncogenes).
- (d) Surgery, radiotherapy, Chemotherapy
19. (a) Malaria
- (b) Different species of *Plasmodium* viz *P. vivax*, *P. Malariae* and *P. falciparum*.
- (c) Malaria is caused by the toxins (haemozoin) produced in the human body by the malarial parasite. This toxin is released by the rupturing of RBCs.
- (d) Life cycle of *Plasmodium* : Fig. 8.1 Page 148, NCERT book, Biology - XII
20. (i) AIDS (Acquired Immuno Deficiency Syndrome)
- (ii) HIV (Human Immunodeficiency Virus)
- (iii) Helper T-cells, macrophages, B-lymphocytes.
- (iv) *Preventive measures* :
- (a) People should be educated about AIDS transmission.
- (b) Disposable needles and syringes should be used
- (c) Sexual habits should be changed immediately
- (d) High-risk groups should be discouraged from donating blood.
- (e) Routine screening may be done.

## CHAPTER 9

---

# STRATEGIES FOR ENHANCEMENT IN FOOD PRODUCTION

---

---

### POINTS TO REMEMBER

---

**Apiculture** : Rearing of honeybees for the production of honey, beeswax, royal jelly and bee Venom.

**Artificial insemination** : Introduction of semen of good quality of male into the vagina of female.

**Explant** : A part of plant excised from its original location and used for tissue culture.

**Germplasm Collection** : The entire collection having all the diverse alleles for all the genes in the given organism.

**Inbreeding depression** : Continued close inbreeding decreases the fertility and productivity.

**Inbreeding** : Inbreeding refers to the mating of more closely related individuals within the same breed for 4-6 generations.

**Out-breeding** : Out-breeding is the breeding of the unrelated animals, which may be between individuals of the same breed (but having no common ancestors), or between different breeds (cross breeding or different species (interspecific hybridisation)).

**Super Ovulation** : Stimulation of good female animal by administering hormones to produce more eggs.

**Mutation breeding** : Mutation in plants is induced artificially through use of mutagens to obtain desirable characters. These plants (as a source) are used in breeding.

**Totipotency** : The ability to generate a whole plant from any cell/explant.

---

### ABBREVIATIONS

---

<b>ET</b>	:	Embryo Transfer
<b>IARI</b>	:	Indian Agricultural Research Institute
<b>IRRI</b>	:	International Rice Research Institute
<b>ICAR</b>	:	Indian Council of Agriculture Research
<b>MOET</b>	:	Multiple Ovulation Embryo Transfer
<b>NDRI</b>	:	National Dairy Research Institute

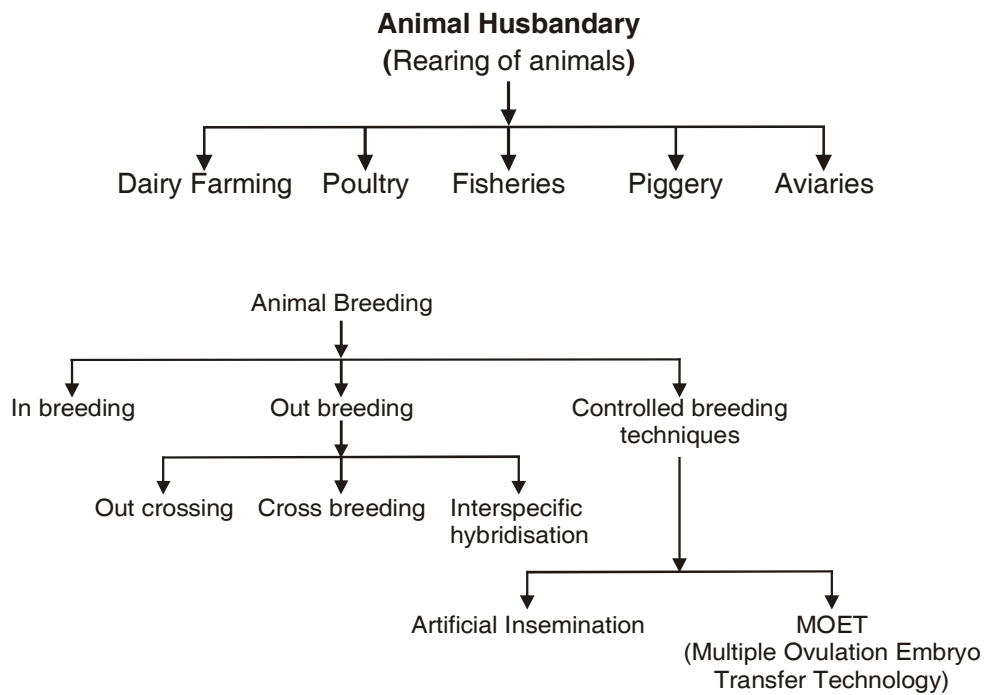

**Plant Breeding for Developing Disease Resistant Varieties**

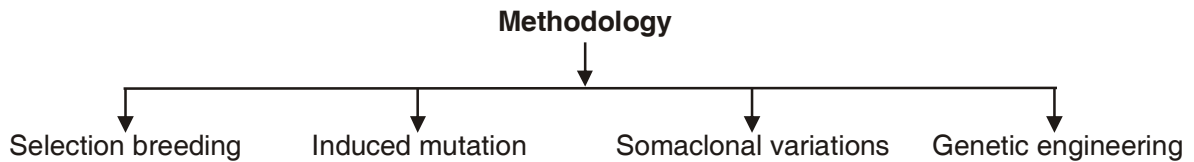
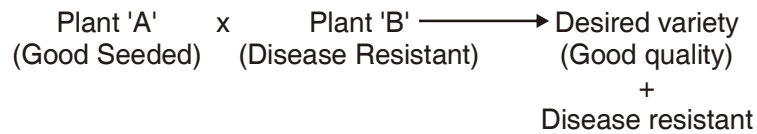

**Somatic Hybridisation**

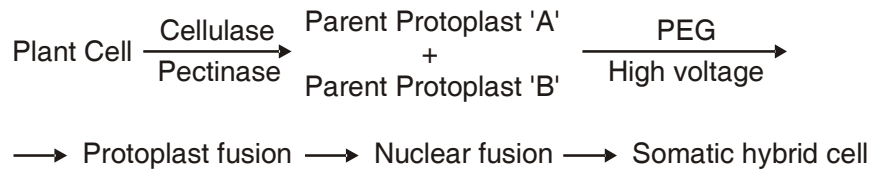

**QUESTIONS**

**VAS (I MARK)**

1. Why is inbreeding necessary in animal husbandary?

2. Name two fungal diseases of Crop plants.
3. Which product of Apiculture is used in cosmetics and polishes?
4. Semi-dwarf varieties of a crop plant were derived from IR-8. Name that crop.
5. Write two qualities of *Saccharum officinarum* (Sugarcane) grown in South India.

**SA - II (2 MARKS)**

6. A new breed of sheep was developed in Punjab by crossing two different breeds of Sheep. Name the two breeds which were crossed and the new breed developed.
7. Study the table given below and fill in the blanks marked A, B, C and D

S.No.	Crop	Variety	Resistant to Disease
1.	Wheat	Himgiri	(A)
2.	<i>Brassica</i>	(B)	White rust
3.	(C)	Pusa Komal	Bacterial blight
4.	Chilli	(D)	Chilly mosaic Virus, Tobacco mosaic Virus and leaf curl

8. Why are proteins synthesized from *Spirulina* called Single called Proteins? What is the significance of such a protein?
9. Differentiate between inbreeding and outbreeding in animals.
10. Observe the process of Somatic hybridisation given below and fill in the blanks.

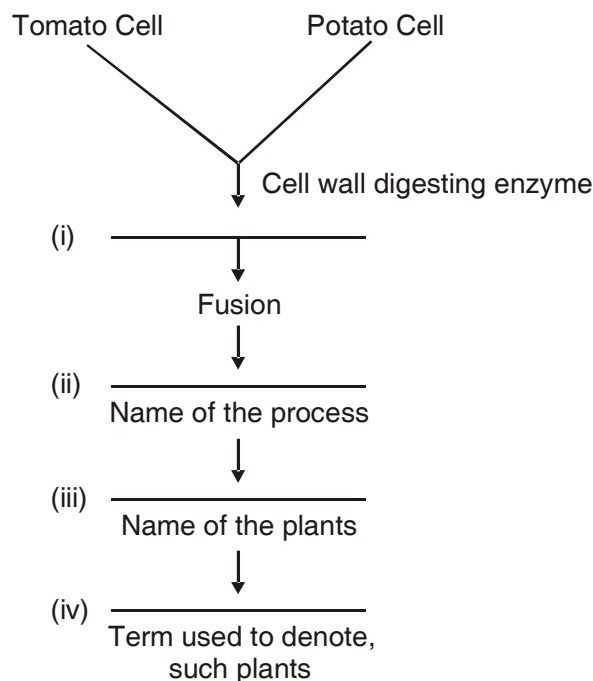

### SA I (3 MARKS)

11. What is micropropagation? Why are plants produced by this technique called somaclones? Name any two food plants which are produced on commercial scale using this method.
12. What is mutation? Explain the significance of mutation in plant breeding. Give an example of a disease resistant variety of cultivated plant induced by mutation.
13. How can we improve the success rate of fertilisation during artificial insemination in animal husbandry programmes?
14. Biofortification is the most practical means to improve public health. Justify the statement with examples.
15. What is meant by germplasm Collection? Describe its significance in plant breeding programmes.

### LA - I (5 MARKS)

16. Does apiculture offer multiple advantages to farmers? List its advantages, if it is located near a place of commercial flower cultivation. Name the most common species of bee which is reared in India.
17. What is somatic hybridisation? Describe the various steps in producing somatic hybrids from protoplasts. Mention any two uses of somatic hybridisation.

## ANSWERS

---

### VAS (1 MARK)

1. Inbreeding increases homozygosity.
2. Brown rust of wheat, Smut of wheat, red rot of Sugar cane, Late blight of potato.
3. Beewax.
4. Paddy crop (rice)
5. Thicker stem and higher sugar content.

### SA - II (2 MARKS)

6. By crossing Bikaneri ewes and Marino rams, the new breed *Hisardale* was developed.
7. A – Leaf and Stripe rust, hill bunt.  
B – *Pusa swarnim* (Karan rai).  
C – Cowpea  
D – *Pusa Sadabahar*

8. The protein rich food produced by microbes is called as single called protein (SCP) *Spirulina* is a microorganisms which has more protein. It is a quick method of protein production because the growth rate of microbes is enormous. Hence, it provides a protein rich diet for human beings.
9. When breeding is between animals of the same breed, it is called inbreeding, while cross between different breeds in called out breeding.
10.
  - (i) Isolation of protoplast of Tomato cell and Potato cell.
  - (ii) Somatic hybridisation.
  - (iii) Pomato
  - (iv) Somatic hybrid

### SA - I (3 MARKS)

11.
  - The method of producing many plants through tissue culture is called micropropagation.
  - The plants produced through micropropagation will be genetically identical to the original plant from which they were grown, hence are called somaclones.
  - Tomato, banana, apple are produced on commercial scale using this method.
12. **Mutation** : Sudden inheritable change in the characters of an organism due to change in the sequence of bases in the gene(s).
  - Mutation results in a new character or trait, not found in the parental type
  - It can also be induced by using mutagens like gamma radiations.
  - Such plant materials are used as such or used for breeding new varieties.
  - Mung bean resistance to yellow mosaic virus and powdery mildew.
13. The multiple ovulation Embryo Transfer (MOET) technology can improve the success rate of fertilisation.  
  
 In the procedure, a cow is given hormonal treatment (FSH), so that more than one ova/eggs (6-8) are produced per cycle. After mating or artificial insemination the embryos at 8-32 called stage are transferred to different surrogate mother cows. This technology has been successfully used for cattle sheep, rabbit, mares and buffaloes.
14. Biofortification is the plant breeding programme designed to increase Vitamins, minerals, heigher proteins and healthier fat content in crops. This programme improves the quality of food products. It is required to prevent hidden hunger. Some of the examples of fortified crops are:
  - (i) **New hybrid of maize** : had twice the amount of amino acid lysine and tryptophan.
  - (ii) **Wheat** : Atlas 66, having a high protein content.
  - (iii) **Rice** : 5 times iron than the normal amount. IARI Delhi has released several crops which are rich in vitamins and minerals. Consumption of such biofortified food will vastly improve the public health.

15. The collection of all the diverse alleles of all the genes of crop plant is called germ plasm collection.

In plant breeding programmes, the germplasm provides the entire of genes and alleles, and the characteristics which they express. The plant breeders select the most favourable characters of a particular gene and manipulate its transfer to a desirable parent.

### LA (5 MARKS)

16. Apiculture or Bee-Keeping is the maintenance of hives of honeybees for the production of honey. Apiculture is beneficial for farmers in many ways. Honey bee also produces beeswax which is used in industries, such as in preparation of cosmetics and polishes of various kinds. If Bee keeping is practiced in any area the commercial flowers are cultivated, it will be beneficial in the following ways.

- (i) Bees are pollinators of many crop species including flowering crops such as sunflower.
- (ii) It improves the honey yield, because honeybees collect the nectar from flowers for making honey.

*Apis indica* is the most common species which is reared in India.

17. **Somatic Hybridisation** : The process of fusing protoplasts of Somatic cells derived from different varieties or species of plants to produce a hybrid.

#### **Steps :**

- (i) Removal of cell wall of fusing cells by digestion with a combination of pectinase and cellulase to form protoplasts.
- (ii) Fusion between protoplasts of selected parents is induced by the use of polyethyleneglycol (PEG).
- (iii) The resulted product is cultured on a suitable medium to regenerate cell walls.
- (iv) The cells obtained begin to divide to produce plantlets called somatic hybrids.

#### **Uses/Applications :**

- (i) Somaclonal variations can be created
- (ii) Lines or varieties/species of plants which can not be sexually hybridised, they can be hybridised.
- (iii) Allopolyploids can be raised by the method.

## CHAPTER 10

---

# MICROBES IN HUMAN WELFARE

---

---

### POINTS TO REMEMBER

---

**Activated Sludge Process** : Aerobic sewage treatment process using aerobic micro-organisms present in sewage sludge to break down organic matter in sewage.

**Biofertilisers** : Microorganisms which produce fertilisers and enrich the soil *e.g.*, Bacteria, cyanobacteria and fungi.

**Bioactive Molecules** : Molecules produced for commercial use from microbes and used for various purposes *e.g.*, *Trichoderma polysporum* (fungus) is used to obtain immunosuppressive agent cyclosporin A.

**Biochemical Oxygen Demand (BOD)** : Total amount of oxygen consumed by bacteria for oxidation of organic matter present in one litre of water.

**Baculovirus** : Pathogens that attack insects and other arthropods. They are used to kill harmful pests and arthropods *e.g.*, *Nucleopolyhedrovirus*.

**Biocontrol Agents** : Use of biological methods for controlling plant diseases and pests

**Effluent** : The product of primary treatment of sewage which is passed into large aeration tanks for secondary treatment.

**Fermentation** : The process by which microorganisms turn organic materials such as glucose into products like alcohol.

**Fermentors** : A very large vessel used in industry where microbes are grown on an industrial scale.

**Flocs** : During secondary treatment of effluent, excessive growth of aerobic bacteria and fungi form a mass of mesh like structure called flocs.

**Immunosuppressive Agent** : Chemical substances which suppress the immunity against organ transplant.

**Lactic Acid Bacteria (LAB)** : Bacteria growing in milk and convert it into curd *e.g.*, *Lactobacillus*.

**Organic Farming** : Technique of farming, in which biofertilisers are used to enrich the soil.

**DO** : Dissolved Oxygen

**GAP** : Ganga Action Plan



- KVIC** : Khadi and Village Industries Commission  
**TMV** : Tobacco Mosaic Virus  
**YAP** : Yamuna Action Plan  
**IPM** : Integrated Pest Management.

- ♦ Microbes includes protozoa, bacteria, fungi, microscopic plants, viruses, viroids and prions.

#### Microbes in household products :

Milk  $\xrightarrow{\text{Lactobacillus}}$  Curd

Dough  $\xrightarrow[\text{Fermentation}]{\text{Yeast}}$  Swollen, Little fermented dough

Palm sap  $\xrightarrow{\text{Microbes}}$  Toddy (fermented drink)

#### Microbes in production of Biogas

- ♦ Some bacteria which grow anaerobically on cellulosic material produce large amount of Methane ( $\text{CH}_4$ ), along with Carbondioxide and hydrogen. These bacteria are called *methanogens e.g., Methanobacterium*.
- ♦ Methanogens are naturally found in rumen of cattle and sewage.

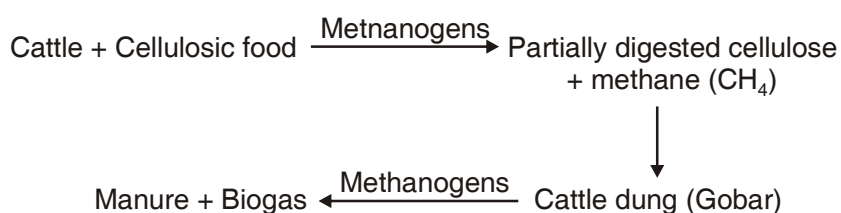

#### Microbes as Biocontrol Agents

Microorganisms	Category	Action
(i) <i>Trichoderma</i> Species	fungus	Kills pathogen in the root system
(ii) <i>Bacillus thuringiensis</i>	bacteria	Kills the insect pest (Bt-cotton)
(iii) <i>Nucleopolyhedrovirus</i> (Baculoviruses)	Virus	Kills insects and other arthropods.

#### Microbes as Biofertilisers

*Rhizobium, Azospirillum, Azotobacter* – (Bacteria) *Anabaena, Nostoc, Oscillatoria* (Cyanobacteria)  
 Genus *Glomus* (Mycorrhiza).

#### Microbes in Industries

- (a) Fermented Beverages : *Saccharomyces cerevisiae* a yeast is used to make bread, fermented fruit juice and alcohol.

(b) Antibiotics : *Penicillium notatum*

(c) Other chemicals /enzymes/Bioactive molecules Many organic acids, enzymes are also produced by microorganisms

S.No.	Microbe	Category	Product
1.	<i>Aspergillus niger</i>	Fungus (Yeast)	Citric Acid
2.	<i>Acetobacter aceti</i>	Bacterium	Acetic acid (Vinegar)
3.	<i>Saccharomyces cerevisiae</i>	Fungus	Ethanol
4.	<i>Lactobacillus</i>	Bacteria	Lactic acid
5.	<i>Streptococcus</i>	Bacteria	Streptokinase
6.	<i>Clostridium butylicum</i>	Bacteria	Butyric acid
7.	<i>Monascus purpureus</i>	Fungus (Yeast)	Statin (Blood cholesterol lowering agent)
8.	<i>Trichoderma polysporum</i>	Fungus	Cyclosporin A (Immunosuppressive agent)

### Microbes in sewage Treatment

Heterotrophic microbes present in the sewage are involved in the treatment of water. Some methanogenic bacteria are commonly found in the anaerobic sludge during sewage treatment.

## QUESTIONS

### VSA (I MARK)

1. How does a small amount of curd added to fresh milk convert it into curd? Mention a nutritional quality that get added to the curd.
2. Why is secondary treatment of water in sewage treatment plant called biological treatment?
3. An antibiotic called 'Wonder Drug' was used to treat the wounded soldiers of America during World War-II. Name the drug and the scientist who discovered it.
4. You have observed that fruit juice in bottles bought from the market are clearer as compared to those made at home. Give reason.
5. Alexander Fleming discovered 'Penicillin, but its full potential as an effective antibiotic was established by other scientists. Name the two scientists.
6. Name the plant whose sap is used in making 'Toddy'. Mention the process involved in it.

### SA II (2 MARKS)

7. Name two alcoholic drinks produced in each of the following ways.  
(i) by distillation and (ii) without distillation.
8. Lactic Acid Bacteria (LAB) is commonly used in the conversion of milk into curd. Mention any two other functions of LAB that are useful to humans.

9. How do mycorrhizae function as biofertilisers? Explain with example.
10. Cyanobacteria (Nostoc, Anabaena) are used as biofertilisers in certain crop fields. Name such one crop. Also, mention the names of two other microorganisms which perform the same function.
11. Which Ministry of Govt. of India had initiated Ganga Action Plan and Yamuna Action Plan? What are the objectives of these plans?

### SA I (3 MARKS)

12. Fill in the blanks spaces a, b, c, d, e, and f, given in the following table :

S. No.	Name of Organism	Commercial Product	Application
1.	<i>Penicillium notatum</i>	Penicillium	(a)
2.	(b)	Lactic acid	Making Curd.
3.	<i>Streptococcus</i>	Clot buster enzyme	(c)
4.	<i>Trichoderma polysporum</i>	(d)	Immuno suppressive agent
5.	<i>Saccharomyces cerevisiae</i>	ethanol	(e)
6.	(f)	Swiss cheese	Food Product

13. What is biochemical oxygen demand (BOD) test? At what stage of Sewage treatment this test is performed?

BOD level of three samples of water labelled as A, B and C are 30 mg/L, 10mg/L and 500 mg/L respectively. Which sample of water is most polluted?

14. Given below is the Flow chart of Sewage treatment. Fill in the blank spaces marked 'a' to 'f'.

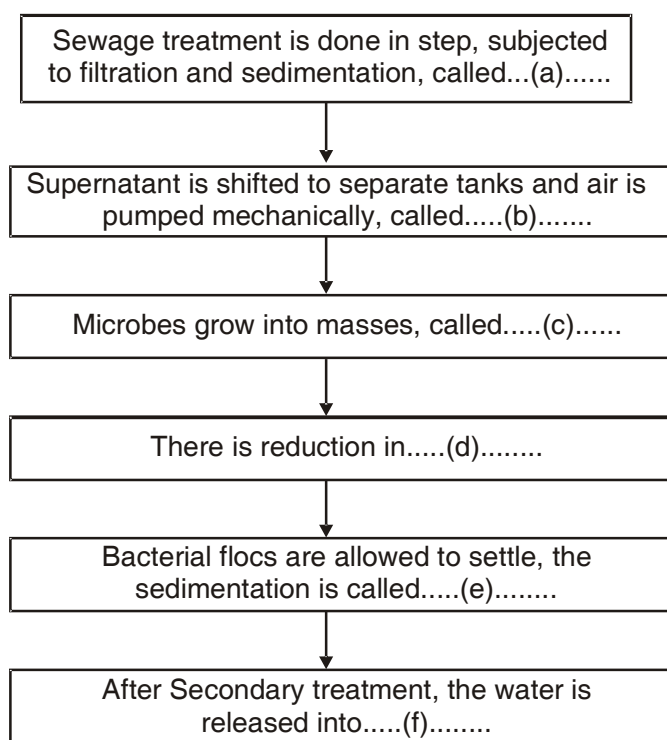

15. What are biofertilisers? A farmer is advised to add a culture of bacterium in the soil before sowing the crop. Name the bacterium in the culture. How is this bacterium useful to the crop?
16. What are statins? Name the microorganism that produces this substance. How is it medically important?

### LA (5 MARKS)

17. How does primary sludge differ from activated sludge? What type of changes in the sludge are carried out in anaerobic sludge digester? Give the composition of biogas produced in the sewage treatment plant.

## ANSWERS

---

### VSA (1 MARK)

1. A large number of lactic acid bacteria are found in small amount of curd which multiply and convert the milk into curd by producing the lactic acid. The nutritional quality improves by increasing Vitamin B<sub>12</sub>.
2. In this treatment Organic wastes of sewage water are decomposed by certain microorganisms in presence of water.
3. Penicillin, Alexander Fleming.
4. Bottle juices are clarified by the use of pectinase and proteases.
5. Ernest chain and Howard Florey.
6. Palm tree, by fermentation.

### SA II (2 MARKS)

7. (i) Whisky, brandy, rum – by distillation  
(ii) Wine, beer – without distillation
8. (i) LAB in human intestine synthesizes Vitamin B<sub>12</sub>.  
(ii) LAB in human stomach checks the growth of harmful microbes.
9. Mycorrhiza are fungi associated with the roots of plants. Many members of genus *Glomus* form mycorrhiza. These fungal symbiont absorbs water and minerals like phosphorus from the soil and provide them to the plant.
10. Peddy (Rice Crop), *Rhizobium* and *Azotobacter*.
11. ♦ The Ministry of Environment and Forests.  
♦ The objective of Ganga Action Plan and Yamuna Action Plan is to save these rivers from pollution. It was proposed to build a large number of sewage treatment plants. So that only treated sewage may be discharged into these rivers.

### SA – I (3 MARKS)

12. (i) to kill disease causing bacteria  
(b) *Lactobacillus*  
(c) remove clots from blood vessels  
(d) Cyclosporin A  
(e) Beverage/medicines  
(d) *Propionibacterium sharmanii*.
13. ♦ The BOD test measures the rate of uptake of oxygen by microorganisms in a sample of water.  
♦ Biological treatment or Secondary treatment  
♦ Sample 'C' is most polluted because it has highest BOD level among the three samples of water.
14. (a) Primary treatment (b) Aeration  
(c) Flocs (d) Biochemical Oxygen Demand (BOD)  
(e) Activated sludge (f) Water bodies like riverstream.
15. ♦ Biofertilisers are organisms that enrich the nutrient quality of the soil.  
♦ Azotobacter/Azospirillum (free living)  
♦ This bacterium fixes atmospheric nitrogen into organic forms, which is used by the plants as nutrient.
16. ♦ Statins are cholesterol reducing agents.  
♦ They are produced by *Monascus purpureus* (Yeast)  
♦ They act by Competitively inhibiting the enzymes responsible for synthesis of cholesterol and are used as blood cholesterol lowering agents.

### LA (5 MARKS)

17. Primary sludge is all solids like soil, small pebbles that settle down in settling tank during primary treatment of sewage.

Activated sludge is the sediment of bacterial 'flocs' in settling tank during biological treatment. Flocs are masses of bacteria held together by slime and fungal filaments. A part of activated sludge is used as inoculum in aeration tank and remaining is passed into a large tank called anaerobic sludge digester. In this tank, other kind of bacteria which grow anaerobically, digest the bacteria, fungi and biomass in the sludge. Biogas that produced in Sewage treatment plant is a mixture of methane, hydrogen and Carbon dioxide.

## CHAPTER 11

---

# BIOTECHNOLOGY : PRINCIPLES AND PROCESSES

---

### POINTS TO REMEMBER

---

**Amplification** : Formation of many copies of a DNA segment in *Vitro*.

**Bacteriophage** : A virus that infects bacteria.

**Bioreactor** : A large vessel in which raw materials are biologically converted into specific products under optimal conditions.

**Biotechnology** : It deals with techniques of using live organisms (Microbes, plants animals) or components for benefit to humans.

According to EFB (European Federation of Biotechnology) : Biotechnology in the integration of natural science and organisms, cells, parts thereof and molecular analogues for products and services.

**Cloning Site** : A location on a cloning vector into where a foreign gene can be inserted.

**Cloning Vectors** : A small, self-replicating DNA molecule into which foreign DNA is inserted in the process of cloning genes.

**Complementary DNA (cDNA)** : A DNA strand formed from mRNA by using the enzyme reverse transcriptase.

**Plasmid** : Extra chromosomal, self replicating circular DNA molecule found in certain bacteria. It has a few genes.

**Genetic Engineering** : The techniques to alter the chemistry of genetic material and introduction of it into organisms to change it phenotype.

**Gel Electrophoresis** : It is a technique to isolate fragments of DNA by forcing them to move through a medium under an electric medium.

**In Vitro** : Any process that is carried out in sterile cultures.

**Ligase** : An enzyme used by a genetic engineer to join the cut ends of the double stranded DNA.

**Palindromic Sequence** : Complementary DNA sequences that are the same when each strand is read in the same direction (5' → 3'). These sequences act as recognition sites for restriction endonuclease.

**Recombinant DNA (rDNA)** : The hybrid DNA formed by combining DNA segment of two different organisms.

**Restriction Enzymes** : The enzyme that cuts out a piece of DNA at a specific site.

**Selectable Marker** : It is a gene which helps in identifying and eliminating non-transformants from transformants (having recombinant DNA).

**Sticky Ends** : Single stranded portions of DNA which can form hydrogen bonds with their complementary cut DNA segments. These ends can be joined by enzyme ligase.

**Taq Polymerase** : A heat stable DNA polymerase isolated from a thermophilic bacterium *Thermus aquaticus* and used in PCR.

**Ti Plasmid** : An extrachromosomal, double stranded and self replicating DNA molecule found in *Agrobacterium tumefaciens* that causes tumor in plants.

**Tools of Recombinant DNA Technology** : Restriction enzymes, polymerase enzymes, ligases, vectors, and host organisms.

**Steps in Formation of rDNA by action of ECORI** : ECORI cuts the DNA between bases G and A only → sticky ends of cut DNAs are formed → DNA fragments join at sticky ends → Recombinant DNA is formed.

**Polymerase Chain Reaction (PCR)** : Denaturation of double stranded DNA → Primers Annealing → Extension → Amplified copies of DNA.

**Process of Recombinant DNA Technology** : Isolation of DNA → Cutting of DNA using restriction endonuclease → Amplification of Gene using PCR → Making rDNA and insertion of it into host cell/organism → obtaining the foreign gene product → Downstream processing.

(i) **Isolation of Genetic Material (DNA)**

- \* DNA can be obtained from the cell by treating with enzymes like, Lysozyme for bacteria, Cellulase for plant cell, Chitinase for fungus.
- \* Histone protein and RNA can be removed by treating with proteases and ribonuclease
- \* Purified DNA ultimately precipitated by the addition of chilled ethanol.

(ii) **Cutting of DNA at specific location** : The purified DNA is cut by the restriction enzymes. Agarose gel electrophoresis used to check the progression of restriction enzymes digestion.

(iii) **Amplification of gene of interest using PCR** : Amplification is the process of making multiple copies of desired DNA segment *in vitro*. Polymerase chain reaction involves three steps”

- (a) **Denaturation** : The target DNA is heated to high temperature (94°C), resulting the separation of two strands of DNA. Each strand acts as template.
- (b) **Annealing** : Two oligonucleotide primers anneal to each of the single stranded DNA template.
- (c) **Extension of primers** : DNA polymerase extends the primers using the nucleotide provided in the reaction.

- (iv) **Ligation** : The cut out 'gene of interest' from the source of DNA and cut vector with space and mixed and ligase enzyme is added—this results recombinant DNA (r DNA).
- (v) **Transfer for recombinant DNA into the host** : The ligated DNA is introduced into the recipient cell. The recipient cell makes itself 'competent' to receive and take up DNA present in the surrounding.
- (vi) **Obtaining the foreign gene product** : The cell containing the foreign gene is cultured on suitable medium and the product can be extracted from the medium.

Bio reactors are used for processing large volume of culture for obtaining products of interest in sufficient quantities.

- (vii) **Downstream Processing** : The products so obtained undergo a series of processes before putting them in market as a finished product. The processes include separation and purification.

The products are formulated with suitable preservation and subjected to quality control testing and clinical trials.

**Essential Feature of a cloning vector** : Ori, Selectable marker, Recognition site, small size.

**Some of the Biotechnological products and processes** : rDNA vaccines, Gene therapy, Test tube babies, syntheses of a gene and introduction of it into a target cell/organism.

**3-Steps in creating GMO** : Identification of gene of interest → Introduction of rDNA into host cell/organism → Maintenance of introduced DNA in the host and transfer of the DNA to its progeny.

**GEL Electrophoresis** : DNA fragments are separated by forcing them to move towards anode under an electric field through a medium. Agarose gel is used as medium. Ethidium bromide is used as stain for DNA, which on exposure to UV-light appear as orange coloured bands. Separated bands of DNA are cut out from agarose gel, this is called elution.

---

## QUESTIONS

---

### VSA (I MARK)

1. A restriction enzyme digests DNA into fragments. Name the technique used to check the progression of this enzyme and separate DNA fragments.
2. Name two commonly used vectors in genetic engineering.
3. Some enzymes are used to cut DNA into fragments. These are considered as molecular scissors. What is the name assigned to such enzymes.
4. Write conventional nomenclature of ECORI.
5. A linear DNA fragment and a plasmid has three restriction sites for ECORI how many fragments will be produced from linear DNA and plasmid respectively.
6. An extra chromosomal segment of circular DNA is used to carry gene of interest into the host cell. What is the name given to it?



7. Identify the recognition sites in the given sequences at which *E.Coli* will be cut and make sticky ends.

5'-GAATTC-3'

3'-CTTAAG-5'

**SA - II (2 MARKS)**

8. Name two main steps which are collectively referred to as down streaming process. Why is this process significant?
9. How does plasmid differ from chromosomal DNA?
10. A bacterial cell is shown in the figure given below. Label the part 'A' and 'B'. Also mention the use of part 'A' in rDNA technology.



11. Mention two classes of restriction enzymes. Suggest their respective roles.
12. In the given process of separation and isolation of DNA fragments, some of the steps are missing, Complete the missing steps –

A : Restriction digestion of DNA fragments
B : .....
C : Staining with ethidium bromide
D : Visualisation in U.V. Light
E : .....
F : Purification of DNA fragments.

**SA - I (3 MARKS)**

13. Since DNA is a hydrophilic molecule, it cannot pass through cell membrane. Name and explain the technique with which the DNA is forced into (i) a bacterial cell (ii) a plant cell (iii) an animal cell.
14. How will you obtain purified DNA from a cell?

15. Recombinant DNA technology vectors are used to transfer a gene of interest in the host cells. Mention any three features of vectors that are most suitable for this purpose.
16. Why is “*Agrobacterium*–mediated genetic engineering transformation” in plants considered as natural genetic engineering?
17. Observe the given sequence of nitrogenous bases on a DNA fragment and answer the following question –

5′ – CAGAATTCTTA – 3′

3′ – GTCTTAAGAAT – 5′

- (a) Name a restriction enzyme which can recognise this DNA sequence.
- (b) Write the sequence after digestion.
- (c) Why are the ends generated after digestion called sticky ends?
18. A selectable marker is used in the section of recombinants on the basis of their ability to produce colour in presence of chromogenic substrate.
- (a) Mention the name of mechanism involved.
- (b) Which enzyme is involved in production of colour?
- (c) How is it advantageous over using antibiotic resistant gene as a selectable marker?

### LA (5 MARKS)

19. The development of bioreactors is required to produce large quantities of products.
- (a) Give optimum growth conditions used in bioreactors.
- (b) Draw a well labelled diagram of simple stirred – tank bioreactor.
- (c) How does a simple stirred – tank’ bioreactor differ from sparged stirred – tank’ bioreactor.
20. In the given figure, one cycle of polymerase chain reaction is shown –

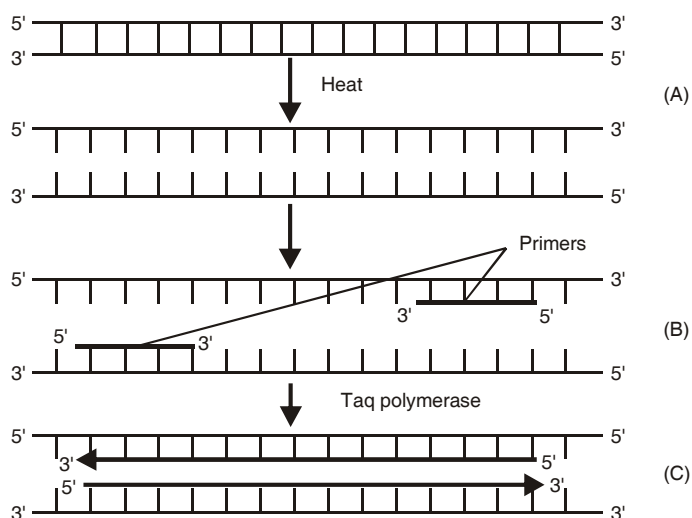

- (a) Name the steps A, B and C.
- (b) Give the purpose of each of these steps.
- (c) State the contribution of *Thermus aquaticus* in this process.
21. Study the figure of vector pBR322 given below in which foreign DNA is ligated at the Bam HI site of tetracycline resistance gene.

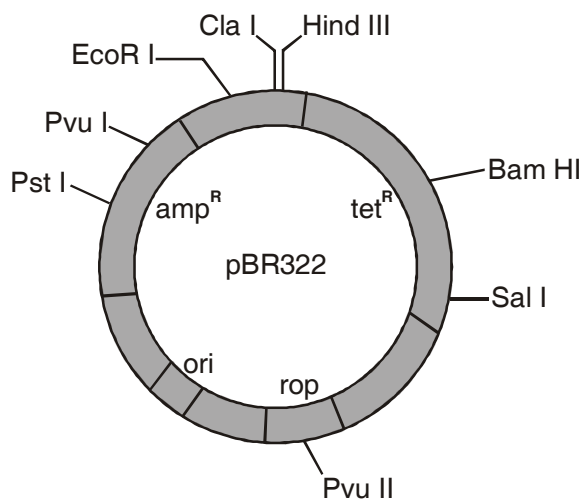

Answer the following questions :

- (a) Mention the function of rop.
- (b) What will be the selectable marker for this recombinant plasmid and why?
- (c) Explain transformation.

## ANSWERS

### VSA (I MARK)

1. Gel electrophoresis
2. Plasmid and Bacteriophage.
3. Restriction Enzymes.
4. E. – *Escherichia*; Co – *coli*; R – Name of Strain; I – order in which enzyme isolated from strain of bacteria.
5. Number of fragments of linear DNA = 4  
Number of fragments of plasmid = 3
6. Plasmid.
7.
 
$$\begin{array}{c}
 \downarrow \\
 5' - G AATTC \quad 3' \\
 3' - CTTAA G \quad 5' \\
 \uparrow
 \end{array}$$

## SA II (2 MARKS)

8. ♦ Separation and Purification
- ♦ This process is essential because before reaching into market, the product has to be subjected for clinical trial and quality control.
- 9.

<i>Plasmid DNA</i>	<i>Chromosomal DNA</i>
(i) Circular DNA	(i) Linear DNA
(ii) Occurs in bacterial cells	(ii) Occurs in nucleus of eukaryotic cells
(iii) Used as Vector	(iii) Not used as vector

10. A – Plasmid, B – Nucleoid

Plasmid is used as vector to transfer the gene of interest in the host cell.

11. ♦ Exonucleases and endonucleases
- ♦ Exonucleases remove nucleotides from the ends of the DNA.
- ♦ Endonucleases cut DNA at specific sites between the ends of DNA.
12. ♦ B – Gel Electrophoresis
- ♦ E – Elution

## SA I (3 MARKS)

13. (i) Chemical treatment and exposure to cold and high temp. (42°) alternatively.
- (ii) Biolistics or gene gun.
- (iii) Micro-injection.
14. ♦ Cells are treated with appropriate enzymes to release DNA.
- ♦ RNA and proteins are removed by treatment with ribonuclease and protease enzymes respectively.
15. (ii) Have origin of replication(Ori)
- (ii) Have a selectable marker
- (iii) Have at least one recognition site.
16. *Agrobacterium tumefaciens* is pathogen in many dicot plants. It is able to deliver a piece of DNA (T-DNA) to transform normal plant cell into a tumor and directs these tumor cells to produce the chemicals required by pathogen.

17. (a) ECORI

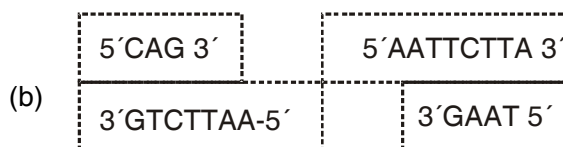

- (c) These are named sticky ends, because they form hydrogen bonds with their complementary cut parts.
18. (a) Insertional inactivation
- (b)  $\beta$ -galactosidase.
- (c) Selection of recombinants due to inactivation of antibiotics requires simultaneous plating on two plates having different antibiotics.

### LA (5 MARKS)

19. (i) Temperature, pH, substrates, salts, vitamins and oxygen.
- (ii) Figure 11.7(a) simple stirred-tank bioreactor Page No. 204 NCERT book, Biology - XII
- (iii) The stirrer facilitates even mixing and oxygen availability throughout simple-stirred tank bioreactor, whereas in case of sparged stirred-tank bioreactor, air is bubbled throughout the reactor for proper mixing.
20. (a) Denaturation – Heat denatures DNA to separate complementary strands.
- (b) Annealing : Primers hybridises to the denatured DNA strands.
- (c) *Extension* : Extension of primers resulting in synthesis of copies of target DNA sequence.
21. (a) 'rop' codes for the proteins involved in the replication of plasmid
- (b) Selectable marker – ampicillin resistance gene
- It will help distinguishing transformants from non-transformants after plating them on ampicillin containing medium.
- (c) *Transformation* – It is the phenomenon by which the DNA isolated from one type of cell and introduced into another type, is able to bring about some of the properties of former to the later.

## CHAPTER 12

---

# BIOTECHNOLOGY AND ITS APPLICATIONS

---

---

### POINTS TO REMEMBER

---

**Adenosine Deaminase (ADA) Deficiency** : ADA enzyme is required for proper functioning of immune system. This disorder is caused due to the deletion of gene for adenosine deaminase enzyme.

**Bt Cotton** : It is transgenic plant. Bt toxin genes were isolated from *Bacillus thuringiensis* and were incorporated into cotton plant.

**Biopesticides** : Biological agents that are used to control weeds, insects and other pests.

**Cry Gene** : The Bt toxins are coded for Bt toxins.

**Cry Protein** : The insecticidal protein which is produced by *Bacillus thuringiensis*.

**Green Revolution** : Substantial increase in crop yields due to use of high yielding varieties, use of fertilisers and pesticides, improved agricultural practices etc.

**Genetically Modified Organisms (GMO)** : The organisms which have altered genes in them. These are also known as transgenic organisms.

**Molecular Diagnosis** : Refers to early detection of diseases using recombinant DNA molecules and techniques like PCR and autoradiography.

**RNA Interference (RNA i)** : Process used to develop pest resistant plants. It involves silencing of a specific mRNA due to complementary double stranded RNA.

**Sustainable Agriculture** : It involves organic farming and other integrated management practices which maintain soil fertility while increasing crop productivity.

**Use of GM Plants** : Tolerant to abiotic stress, Reduced dependence on chemical pesticides, less post harvest-loss, Efficient use of minerals, enhanced nutritional value.

**Uses of Transgenic Animals** : To study normal physiology and development, to study diseases, to get biological products, To test vaccine and chemical safety testing.

**Gene Therapy** : It is a technique of inserting genes into the cells and tissue of an individual to treat a hereditary disease.

- ♦ The first clinical gene therapy was given in 1990 to a four year old girl with adenosine deaminase deficiency.
- ♦ This disorder is caused due to the deletion of the gene for adenosine deaminase.

- ♦ In some children ADA deficiency can be cured by bone marrow plantation. Lymphocytes from the blood of patient are grown in a culture. A functional ADA cDNA is then introduced into these lymphocytes. The lymphocytes are transferred into the body of patients.
- ♦ As these cells are not immortal, the patient required periodic infusion of such genetically engineered lymphocytes.

**Permanent Cure :** If a functional gene is introduced into a bone marrow cells at early embryonic stage. It could be a permanent cure.

**Bt. Cotton :** The soil bacterium *Bacillus thuringiensis* produced crystal protein called *cry protein* that kills certain insects larvae such as tobacco budworm armyworm, beetles and flies.

- ♦ Bt toxin protein exists as inactive *protoxins*, but once an insect ingest this inactive toxin it is converted into active form of toxin due to the alkaline pH of the gut which solubilise the crystal. This causes swelling and lysis of cell leading to death of insect larvae.
- ♦ Bt toxin genes were isolated from *Bacillus thuringiensis* and incorporated into the several crop plants such as cotton.
- ♦ The proteins encoded by *cryIAc* and *cryIIAb* control the cotton bollworms and *cryIAb* control corn borer.

**Pest Resistant Plant :** A nematode *Meloidogyne incognita* infects tobacco plants and reduces their yield.

- ♦ Nematode specific genes were into the host plant using *Agrobacterium* as vector.
- ♦ The introduction of DNA was such that it produced both sense and anti-sense RNA in the host cells.
- ♦ These two RNAs being complementary to each other formed a double stranded RNA (dsRNA) making it inactive.
- ♦ This dsRNA molecule binds to and prevents translation of mRNA of the nucleotide by the process called RNA interference (RNAi).
- ♦ The result was that the parasite could not survive in the transgenic host and the transgenic plant got protected for the parasite.

### Three Critical Research Areas of Biotechnology

- Providing best catalyst in the form of improved organism usually a microbe.
- Creating optimal conditions for a catalyst to act.
- Downstreaming processing technologies to purify the desirable product.

---

## QUESTIONS

### VSA (I MARK)

- Name the technique based on the principles of antigen-antibody used in detection of a virus.

2. Development of a transgenic food crop may help in solving the problem of night blindness in the developing countries, name this crop plant.
3. Which nematode infects the roots of tobacco plant and causes a great reduction in yield?
4. The first transgenic cow, produced human protein – enriched milk. Name the cow and the protein found in milk.
5. The insulin produced using recombinant DNA technology is more advantageous than the insulin extracted from pancreas of slaughtered cattle and pigs. How?
6. Name two pest resistant plants produced by using recombinant DNA technology.

### **SA – II (2 MARKS)**

7. What are the two methods for correcting ADA deficiency in a child?
8. Some crop plants are modified genetically by manipulating their genes. How are they made beneficial?
9. GEAC is one of the organization set up by Indian Government. Write its full form. Give its two objectives.
10. “Industrialised nations are exploiting the bioresources of under industrialised nations”. Justify the statement with a suitable example.

### **SA – I (3 MARKS)**

11. Some multinational companies and other organisations are using bioresources for commercial benefits, without proper authentication and compensation to concerned authorities.
  - (a) Give the term for this unauthorised act.
  - (b) Suggest any two ways to get rid of this.
12. A bacterium *Bacillus thuringiensis* produces a toxic protein named ‘cry protein’ that is lethal to certain insects but not to bacterium
  - (a) Why this toxin does not kill the bacteria?
  - (b) What type of changes occur in the gut of insects on consuming this protein?
  - (c) How man has exploited this protein for his benefit?
13. Given below is an incomplete flow chart showing the process of production of nematode resistant tobacco plants based on RNAi technique.
  - (i) Write the missing steps in proper sequence
  - (ii) At which level RNAi silences the gene



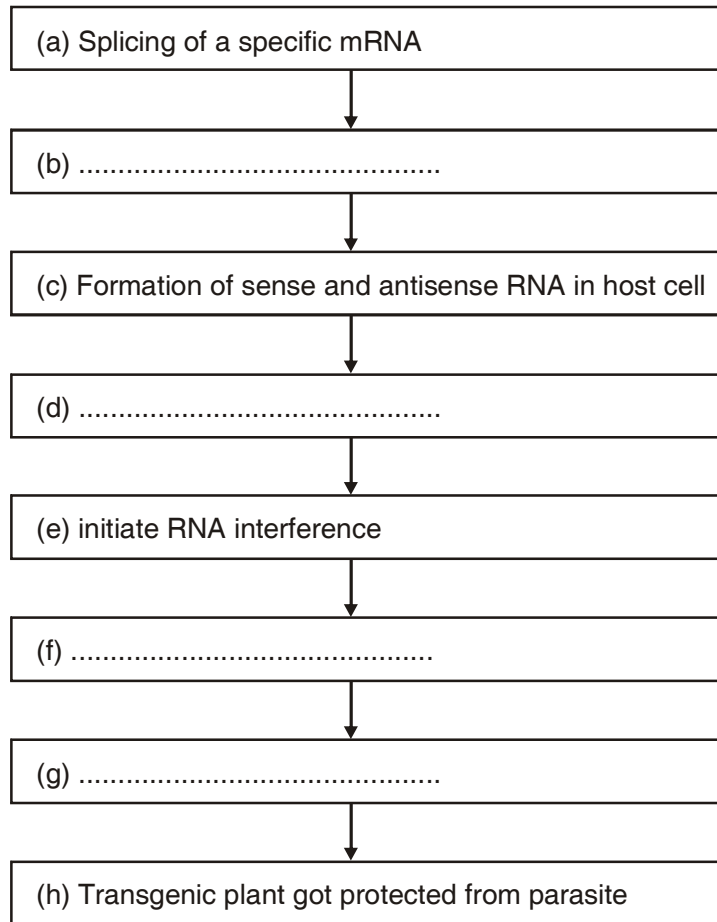

**LA (5 MARKS)**

14. The clinical gene therapy is given to a 4 years old patient for an enzyme which is crucial for the immune system to function.

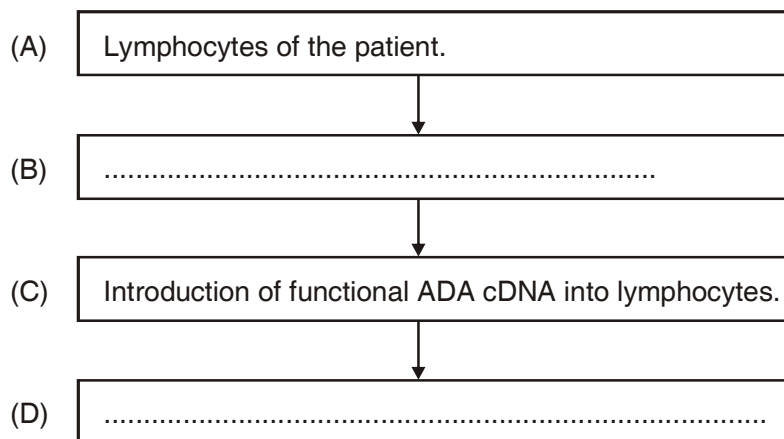

Observe the therapeutical flow chart and give the answer of the following :

(a) Complete the missing steps (B) and (D)

- (b) Identify the disease to be cured.
- (c) Why the above method is not a complete solution to the problem?
- (d) Scientists have developed a method to cure this disease permanently. How?
15. In the given figure, *Agrobacterium* is utilized for the production of a transgenic crop. Explain the steps a, b, c, d and e shown in the figure.

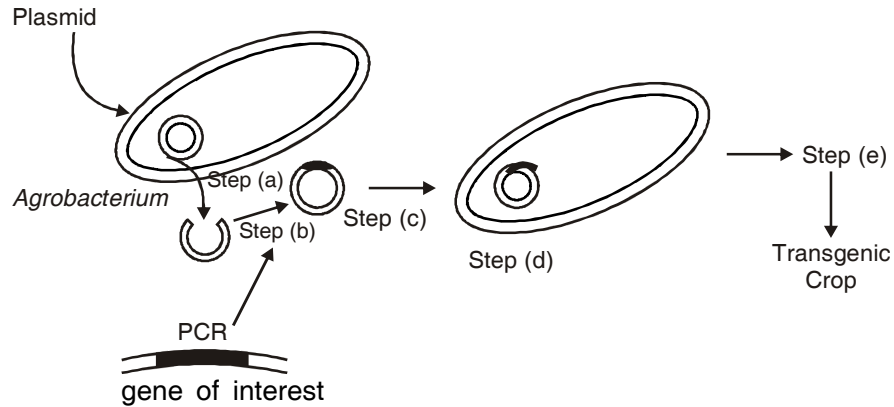

16. In the given figure, Form (A) and Form (B) represents different forms of a proteinaceous hormone secreted by pancreas in mammals.

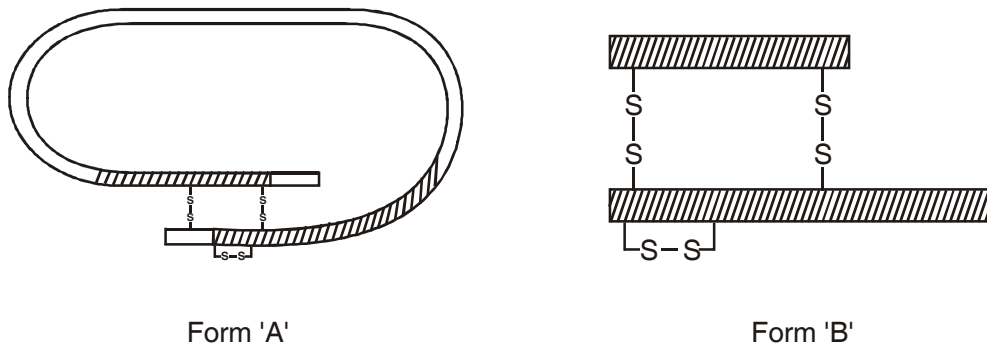

- (a) What type of bonding is present between chains of this hormone?
- (b) What are these form (A) and form (B). How these forms differ from each other?
- (c) Explain how was this hormone produced by Eli Lilly, an American company, using rDNA technology.

## ANSWERS

### VAS (I MARK)

1. ELISA
2. Golden Rice
3. *Meloidogyne incognita*.

3. Rosie, alpha-lactalbumin
4. Insulin obtained from animal source causes allergy.
5. Bt Cotton, Bt Corn, Bt Brinjal.

### **SA – II (2 MARKS)**

6. Bone marrow transplantation having functional ADA enzyme and Enzyme replacement therapy.
7. More tolerant to abiotic stresses; pest resistant; reduction in post harvest losses; increased nutritional value of food.
8. GEAC – Genetic Engineering approval committee. Objectives of GEAC are
  - (i) To make decisions regarding validity of GM research.
  - (ii) Safety of introducing GMO for public use.
9.
  - ♦ Industrialised nations are collecting and patenting the genetic resources of under industrialised country like India. An American Company got patent rights on Basmati rice.
  - ♦ Valuable biomolecules obtained from bioresources are patented and used for commercial purposes.

### **SA – I (3 MARKS)**

10. (a) Biopiracy
  - (b)(i) Benefits of bio resources should be shared between developed and developing nations
  - (ii) Laws should be developed to prevent unauthorised exploitation of them bio resources.
11. A crop that contain and express a transgene is called transgenic crop or genetically modified (GM) crop.
12. (a) Produced in inactive form as Prototoxins.
  - (b) Prototoxin becomes active toxin in alkaline pH of gut of insects. Toxins bind to surface of midgut and cause perforation, swelling, lysis of cells ultimately leading to death.
  - (c) Specific Bt toxin genes isolated from *Bacillus thuringiensis* and incorporated into several crop plants such as cotton and corn which become pest resistant against certain insects.
13. (i) (b) Using *Agrobacterium* as a vector, introduced into tobacco
  - (d) dsRNA (double stranded RNA)
  - (f) Silenced specific mRNA of the nematode
  - (g) Parasite could not survive.
- (ii) RNAi silences the gene at translation level

14. (a) Step (B) : Lymphocytes are grown in culture medium.  
Step (D) : Infusion of genetically engineered lymphocytes into patients.
- (b) Adenosine deaminase (ADA) deficiency.
- (c) As genetically engineered lymphocytes are not immortal, the patient requires periodic infusion of cells.
- (d) If the gene isolated from bone marrow cells producing ADA is introduced into cells at early embryonic stages, it could be a permanent cure.
15. **Step (a)** Plasmid is removed and cut open with restriction endonuclease.
- Step (b)** Gene of interest is isolated from another organism and amplified using PCR
- Step (c)** New gene is inserted into plasmid
- Step (d)** Plasmid is put back into *Agrobacterium*
- Step (e)** Agrobacterium based transformation.
- Mis-uses** : Favour rich industrialised nation, biopiracy, bio-war.
16. (a) Disulphide bonds
- (b) Form (A) – Proinsulin  
Form (B) – Mature insulin.  
Proinsulin contains an extra stretch called C – peptide which is absent in mature insulin.
- (c) Eli Lilly company prepared two DNA sequences corresponding to A and B peptide chains of human insulin and introduced them in plasmid *E. coli* to produce insulin chains. Chains A and B were produced separately, extracted and combined by creating disulphide bonds to form insulin.

## CHAPTER 13

---

# ORGANISMS AND POPULATIONS

---

---

### POINTS TO REMEMBER

---

**Adaptation** : Any attributes of the organism (morphological, physiological, behavioural) that enables the organism to survive and reproduce in its habitat.

**Aestivation** : Strategy to escape in time during summers (summer sleep). E.g., Snails and some fishes.

**Allen's Rule** : Mammals from colder climates generally have shorter ears and limbs to minimise heat loss.

**Carrying Capacity** : Maximum number of individuals of a population which can be provided with all the necessary resources for their healthy living.

**Commensalism** : One organism is benefitted while the other is neither harmed nor benefitted except to a negligible extent.

**Competition** : Rivalry between two organisms for obtaining the same resources.

**Ectoparasite** : Parasites which live on the surface of their host.

**Emigration** : Number of individuals of the population who have left the habitat and gone elsewhere during a given time period.

**Exponential Growth Curve** : Shows that if food and space for a population are unlimited and each species has the ability to grow, then the population grows in exponential or geometric ratio.

**Hibernation** : Strategy to escape in time during winters (winter sleep). E.g., Polar bears.

**Homeostasis** : Maintaining constancy of internal environment despite varying external environmental conditions.

**Immigration** : Number of individuals of the same species that have come into the habitat from elsewhere during a given time period.

**Ecology** : A branch of science that studies the reciprocal relationships between organism and their physical environment. Ecology is basically concerned with four levels of biological organisation—organisms, populations, communities and biomes.

**Organisms** : Organisms form the basic unit of study in ecology. Organisms with similar features and the potential interbreed among themselves and produce fertile offspring, constitute a species.

**Populations** : Population is a group of individuals of the same species, inhabiting in a given area. Interspecific competition for basic needs operate among the individuals of a population.

**Biological Community** : Biological community is constituted by an assemblage of the populations of all different species that live in an area and interact with each other. A biotic community has a distinct species composition and structure.

**Biomes** : Biome is a very large unit, constituting of a major vegetation type and associate fauna found in a specified zone. Annual variations in the intensity, duration of temperature and precipitation account for the formation of major biomes like desert, rain forest and tundra.

**Major Biomass of India** : Tropical rain forest, deciduous forest, desert, sea coast. Regional and local variations within each biome lead to the formation of a wide variety of habitats.

**Environment** : Environment is a sum total of all biotic and abiotic factors that surround and potentially influence an organism. Temperature, water, light and soil are the major abiotic factors.

**Response to Abiotic Factors :**

- (i) **Regulators** : Some organisms are able to maintain homeostasis by physiological (Some times behavioural) means which ensures body temperature, constant osmotic concentration. All birds and mammals, a very few lower vertebrates and invertebrates are regulators (Thermoregulation and osmoregulation). For example, human beings maintain their body temperature by sweating in summer and shivering during winter season. Plants do not have such mechanisms to maintain internal temperatures.
- (ii) **Conformers** : Majority of animals and nearly all plants cannot maintain a constant internal environment. Their body temperature changes with the ambient temperature. In aquatic animals the osmotic concentration of the body fluids change with that of the ambient water and osmotic concentration. Some species have evolved the ability to regulate, but only over a limited range of environmental conditions, beyond which they simply conform.

A diagrammatic representation of organismic response is shown below.

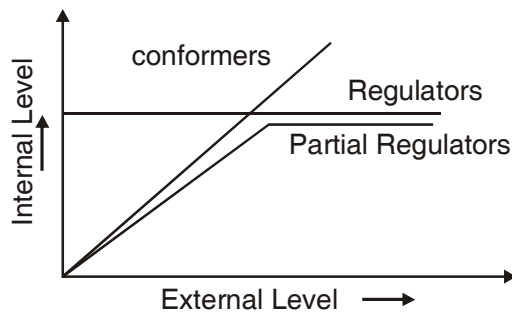

- (iii) **Partial regulators** : *Hair on the body* – Hair on body acts as heat insulator.  
*Surface area and volume ratio* – In smaller organisms the surface area is large as compared to the volume. But in large animal this ratio is small. So, the larger animals effectively controls the body temp.
- (iv) **Migration** : The organisms can move away temporarily from the stressful habitat to a more hospitable area and return when stressful period is over.
- (v) **Suspend** : The organisms may avoid the stress by escaping in time. Bears go into hibernation winter, some snails and fish go into aestivation in summer.

**Age Pyramids of Populations :** A population at any given time is composed of individuals of different ages. If the age distribution is plotted for the population, the resulting structure is called an age pyramid. The shape of the pyramids reflects the growth status of the populations (a) Whether it is growing (expanding) (b) Stable or (c) Declining. Age pyramids for human population (males and females) are represented below.

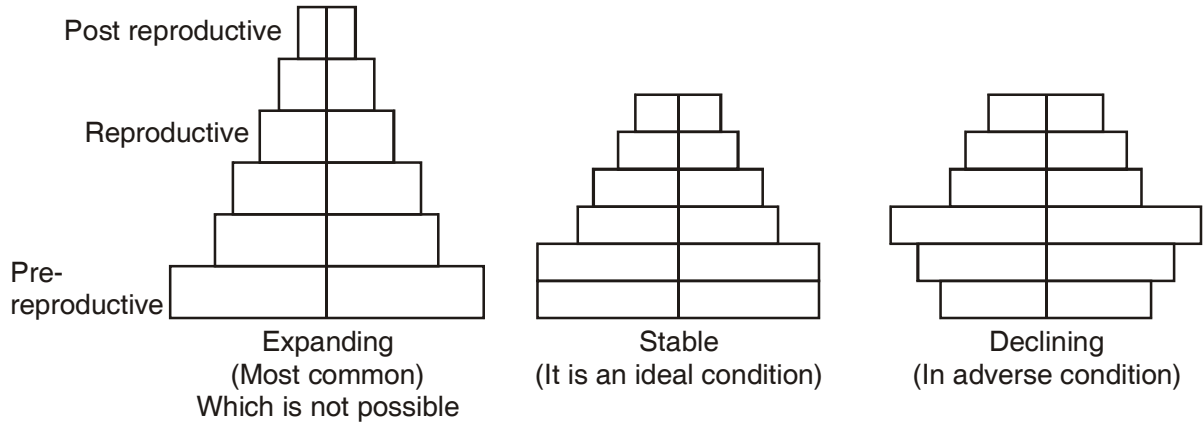

**Population Growth :** If 'N' is the population density at time 't', then its density at time t + 1 is :

$$N_{t+1} = N_t + [(B + I) - (D + E)]$$

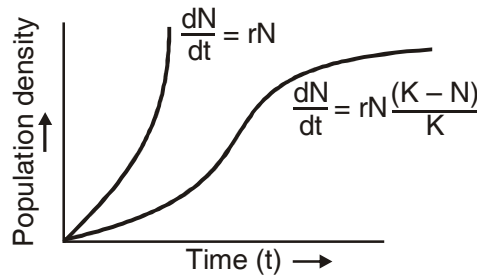

Where B = The number of births

I = The number of immigrants

D = The number of deaths

E = The number of Emigrants.

N = Population Density

r = Intrinsic rate of natural increase

t = Time period

K = Carrying capacity (The maximum population size that an environment can sustain)

### Population Interactions :

**Predation :** Interaction between species involving killing and consumption of prey is called predation. The species which eats the other is called the predator and the one consumed is termed the

prey. The predator keeps check on prey population. The reduction in predator population may lead to increase in prey population.

**Commensalism** : This is the interaction in which one species benefits and the other is neither harmed nor benefited under normal conditions.

**Parasitism** : Parasitism is a kind of relationship between two species in which one derives its food from the other (host). Parasitism also involves shelter, in addition to food obtained by a parasite. Parasites may be ectoparasites or endoparasites.

**Mutualism** : In mutualism both the interacting species are benefited mutually. It is also known as symbiosis.

**Amensalism** : Interaction between two different species, in which one species is harmed and the other is neither benefited nor harmed.

**Examples of Parasitism :**

- (i) *Cuscuta* growing in shoe flower plant
- (ii) Head louse and humans
- (iii) *Ascaris*, *Taenia*, *Plasmodium* causing diseases in humans

**Examples of Brood parasitism :**

- (i) Koel laying its eggs in crow's nest.

**Examples of Commensalism :**

- (i) Clown fish living among tentacles of sea anemone
- (ii) Pilot fish (*Remora*) accompanies sharks
- (iii) Orchid growing on mango tree
- (iv) Sea anemone on the shell of hermit crab
- (v) Barnacles on back of whales
- (vi) Egret and grazing cattle

**Examples of Mutualism**

- (i) Mycorrhiza living in roots of higher plants
- (ii) Rhizobium in root nodules of legumes
- (iii) Algae and fungi in lichens
- (iv) Orchid *Ophrys* and bee for pollination

**Example of Amensalism**

- (i) *Penicillium* whose toxin kills many bacteria is neither benefited nor harmed



## Examples of Predation

- (i) Biological control methods to control pests
- (ii) Carnivorous animals like tiger eating deers, snake eating frog
- (iii) Insectivorous plants like *Nepenthes*, *Drosera*, *Utricularia*

**Growth Models** : The two growth models are :

(i) **Exponential growth model**

**Exponential Growth Equation** is  $N_t = N_0 e^{rt}$

Where

$N_t$  = Population density after time t

$N_0$  = Population density at time zero

r = intrinsic rate of natural increase

e = the base of natural logarithms (2.71828)

(ii) **Logistic growth model**

*Verhulst-Pearl Logistic Growth* is described by the following equations :

$$dN/dt = rN (K-N / N)$$

Where N = Population density at time t

r = Intrinsic rate of natural increase

K = Carrying capacity

(i) **Exponential growth** (*'J' shape curve is obtained*).

- \* When responses are not limiting the growth.
- \* Any species growth exponentially under unlimited resources conditions can reach enormous population densities in a short time.
- \* Growth is not so realistic.

(ii) **Logistic Growth** (*Sigmoid curve is obtained*)

- \* When responses are limiting the Growth.
- \* Resources for growth for most animal populations are finite and become limiting.
- \* The logistic growth model is a more realistic one.

## QUESTIONS

---

### VSA (I MARK)

1. Which are the factor responsible for the wide variety of habitat formed within each biome?
2. Fresh water animals are unable to survive for long in sea water. Give reason.
3. With which population growth model is the Verhulst Pearl equation associated?
4. Define diapause. Which organisms exhibit it?
5. Calculate the death rate if 6 individuals in a laboratory population of 60 fruit flies died during a particular week.
6. In biological control method, one living organism is used against another to check its uncontrolled growth. Which kind of population interaction is involved in this?
7. An organism has to overcome stressful condition for a limited period of time. Which strategies can it adopt to do so?

### SA - II (2 MARKS)

8. What are the four levels of biological organisation with which ecology basically deals?
9. Differentiate between stenohaline and euryhaline organisms.
10. List four features which enable the Xeric plants to survive in the desert conditions.
11. Mention the attributes which a population has but not an individual organism.
12. Differentiate between stenothermal and eurythermal organisms.
13. What are the four ways through which the living organisms respond to abiotic factors?

### SA - I (3 MARKS)

14. How does the shape of age pyramid reflect the growth status of a population.
15. Darwin showed that even a slow growing animal like elephant could reach enormous number in absence of checks. With the help of your understanding of growth models, explain when is this possible? Why is this notion unrealistic?
16. How will you measure population density in following cases?
  - (i) fish in a lake
  - (ii) tiger census in a national park
  - (iii) single huge banyan tree with large canopy.
17. Species facing competition might evolve mechanism that promotes co-existence rather than exclusion. Justify this statement in light of Gause's competitive exclusion principle, citing suitable examples.

### LA (5 MARKS)

18. What is altitude sickness? What its causes and symptoms? How does human body try to overcome altitude sickness?
19. Orchid flower, Ophrys co-evolves to maintain resemblance of its petal to female bee. Explain how and why does it do so?

### ANSWERS

---

#### VSA (I MARK)

1. Regional and local variations
2. Due to osmotic problems.
3. Logistic Growth.
4. A stage of suspended development, zooplanktons.
5.  $6/60 = 0.1$  individuals per fruitfly per week.
6. Predation.
7. (i) Migration  
(ii) Suspension of active life by hibernation/aestivation/spore formation.

#### SA-II (2 MARK)

8. Organisms, population, communities and biomes.
9. **Euryhaline** : Organisms tolerant in wide range of salinities.  
**Stenohaline** : Organisms tolerant to narrow range of salinities.
10. (i) thick cuticle  
(ii) Stomata in deep pits  
(iii) Stomata closed during day time  
(iv) leaves reduced to spines (CAM photosynthetic pathway).
11. Birth rate, Death rate, Sex ratio, age groups.
12. **Eurythermal** : Organisms that can tolerate and thrive in wide range of temperatures  
**Stenothermal** : Organisms restricted to a narrow range of temperature.
13. (i) Regulate (ii) Conform (iii) migrate (iv) Suspend

### SA-I (3 MARKS)

14. Shape of pyramids reflects growth status of the population (a) growing (b) Stable (c) declining.  
Refer page 227, Fig. 13.4, NCERT book, Biology - XII
15. Possible if the growth model is Exponential, *i.e.*, having unlimited resources. Its an unrealistic situation because resources are limited. Hence, it follows logistic growth model.
16. (a) fish caught per trap.  
(b) number per unit area  
(c) percentage cover in biomass.
17. State Gause's competitive exclusion principle. Mechanisms is resource partitioning. *E.g.*, experiment of Mac Arthur on Warblers (Refer page 325, NCERT book, Biology - XII).

### LA (5 MARKS)

18. Breathlessness at high attitudes.

**Cause** : Low atmospheric pressure at high altitudes due to which body does not get enough oxygen.

**Symptoms** : Nausea, fatigue and heart palpitations.

**Body adapts by :**

- (a) increasing red blood cell production  
(b) decreasing binding affinity of haemoglobin  
(c) by increasing breathing rate.
19. ● employs 'sexual deceit'  
● one petal bears uncanny resemblance to female of the bee.  
● Male bee is attracted to what it perceives as a female 'pseudocopulates,' during which pollen dusted on male bee's body.  
● Male bee transfers pollen to another flower when the same bee pseudocopulates with another flower.  
● Ophrys does so because pollination success will be reduced unless it co-evolves with female bee.

## CHAPTER 14

---

# ECOSYSTEM

---

---

### POINTS TO REMEMBER

---

**Stratification** : Vertical distribution of different species occupying different levels in an ecosystem.

**Primary Production** : Amount of biomass or organic matter produced per unit area over a time period by plants during photosynthesis.

**Productivity** : Rate of biomass production. Its unit is  $g/m^2/year$ .

**Gross Primary Productivity** : Rate of production of organic matter during photosynthesis.

**Net Primary Productivity** : Gross primary productivity minus the respiration losses.

**Ecosystem** : Relationship between living organisms and their abiotic surroundings.

**Secondary Productivity** : Rate of formation of new organic matter by consumers.

**Detritus** : Dead leaves, twigs, animal remains etc. constitute detritus.

**Detritivore** : Organisms who break down detritus into smaller particles. *e.g.*, earthworm.

**Ecological succession** : The successive and orderly replacement of one community by the other community in an area, over a period of time.

**Ecological Pyramids** : The sequential graphic representation of an ecological parameter (number/biomass/energy) depicting different trophic levels in a food chain.

**Climax community** : The stable and final biotic community that develops at the end of ecological succession and is in perfect harmony with its physical environment.

**Pioneer species** : The species that invade a bare area at the onset of ecological succession.

**Process of Decomposition** : The decomposers break down complex organic matter into inorganic substances like carbon dioxide, water and nutrients. This process is called decomposition. Steps of decomposition are :

- (i) **Fragmentation** : Break down of detritus into smaller particles by detritivores (earthworm).
- (ii) **Leaching** : Water soluble inorganic nutrients go down into the soil horizon and get precipitated as unavailable salts.
- (iii) **Catabolism** : Bacterial and fungal enzymes degrade detritus into simple inorganic substances.

- (iv) **Humification** : Accumulation of a dark coloured amorphous substances called humus.
- (v) **Mineralisation** : The humus is further degraded by some microbes and release of inorganic nutrients occur.

**Energy Flow** : Energy flow is the key function in the ecosystem. The plants (producers) capture only 2 – 10 percent of the photosynthetically active radiation (PAR). Unidirection flow of energy is taken place from the sun to producers and them to consumers. About 10% energy flows from one trophic level to another.

**Grazing Food Chain** : It begins with producers.

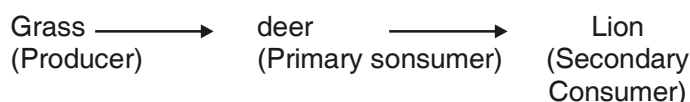

**Detritus Food Chain** : It begins with dead organic matter. It is made up of decomposes (Fungi, Bacteria).

### Ecological Pyramids

- (i) **Pyramid of Numbers** : (Grass land system)

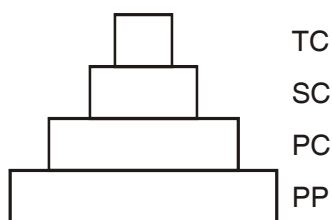

- (ii) **Pyramid of Energy** : (Always upright in all Ecosystems)

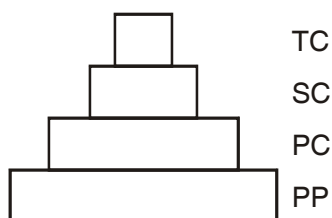

- (iii) **Pyramid of Biomass** :

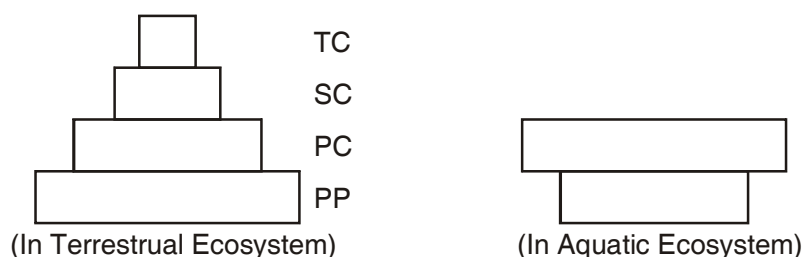

**Ecological Succession** : The gradual and fairly predictable change in the species composition of a given area is called ecological succession. The species that invade a bare area is called **pioneer species**. The final community is an ecological succession that is in near equilibrium with the environment is called **climax community**

*Secondary Succession* begins in the area where natural biotic communities have been destroyed (burned or cut forests, land that have been devastated by flood).

**Succession on a Bare Rock (Xerarch)**

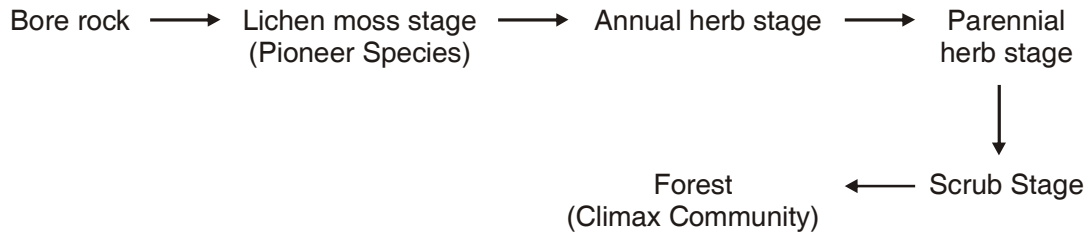

**Succession in Aquatic environment (Hydrarch)**

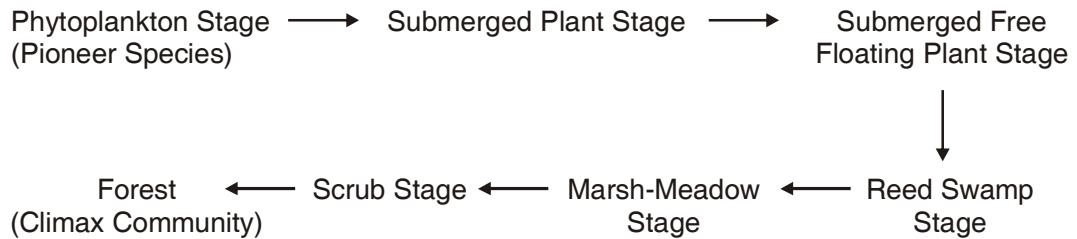

**ABBREVIATIONS**

---

<b>PAR</b>	:	Photosynthetically Active Radiation
<b>GAP</b>	:	Gross Primary Productivity
<b>NPP</b>	:	Net Primary Productivity
<b>DFC</b>	:	Detritus Food Chain
<b>GFC</b>	:	Grazing Food chain

**QUESTIONS**

**VSA (I MARK)**

1. Decomposition is faster if detritus is rich in nitrogen and water soluble substance like sugars. When is the decomposition process slower?
2. If we count the number of insects on a tree and number of small birds depending on those insects as also the number of larger birds eating the smaller, what kind of pyramid of number would we get?
3. Differentiate between Sere and Seral communities.
4. Who are generally the pioneer species in a Xerarch succession and in a Hyararch succession?
5. Which metabolic process causes a reduction in the Gross Primary Productivity?

**SA - II (2 MARKS)**

- What is the shape of pyramid of biomass in sea? Why?
- Give an example of an ecological pyramid which is always upright. Justify your answer.
- Differentiate between primary succession and secondary succession. Which one occurs faster?
- Gaseous nutrient cycle and sedimentary nutrient cycles have their reservoir. Name them. Why is a reservoir necessary?
- Fill up the missing links depicted as A, B, C and D in the given model of primary succession.

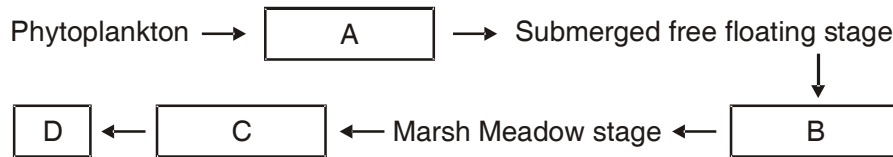

- In the model of phosphorus cycle given below, what does A, B, C and D refer to?

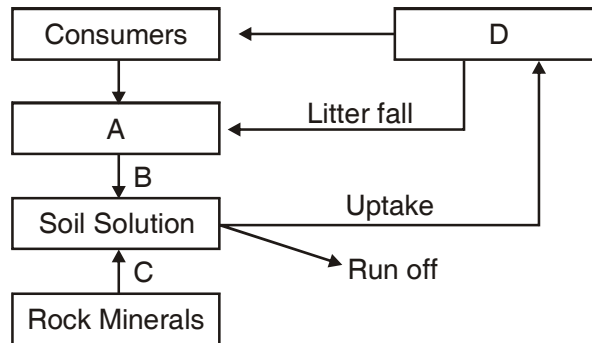

- Differentiate between Hydrarch and a Xerarch succession.

**SA - I (3 MARKS)**

- What are the limitations of ecological pyramids?
- Name any four ecosystem services. Who gave the price tags on nature's life support services? Which is the most important ecosystem service provider?
- Study the table given below and fill the blanks from 'A' to 'F'.

<b>S.No</b>	<b>Component of the Ecosystem</b>	<b>Position of the trophic level</b>	<b>Organism present in the Food chain</b>
1.	E	Fourth trophic level	F
2.	Secondary consumer	D	Bird, fish, wolf.
3.	B	Second trophic level	C
4.	Primary producer	A	Phytoplankton, grass, tree.





### SA-I (3 MARK)

13. (i) Does not take into account same species belonging to two or more trophic levels.  
(ii) Assumes simple food chain, does not accommodate food web.  
(iii) Saprophytes have not been given any place in ecological pyramids.
14. ♦ Forest (ecosystem) purify water and air ♦ Mitigate Droughts and floods  
♦ Nutrient cycling ♦ Generate fertile soil  
♦ Provide habitat for wildlife ♦ Pollinate flower  
♦ Maintain Biodiversity ♦ Provide aesthetic, cultural & spiritual values
- ♦ Robert Constanza gave price tags to ecosystem services.  
♦ Most important ecosystem services provider : Soil formation.
15. A = First trophic level  
B = Primary consumer  
C = Zooplankton, Cow, Grass hopper  
D = Third trophic level  
E = Tertiary consumer  
F = Man, Lion

### LA (5 MARKS)

16. The dead remains of plants and animals called detritus undergo decomposition and are converted into simpler substances. The steps of this process are :
- (i) **Fragmentation** : Breakdown of detritus into smaller pieces by detritivores like earthworm.
- (ii) **Leaching** : Water soluble inorganic nutrients go down into soil horizon and get precipitated as unavailable salts.
- (iii) **Catabolism** : Bacterial and fungal enzymes degrade detritus into simpler inorganic substances.
- (iv) **Humification** : It leads to accumulation of dark coloured amorphous substance called humus which is highly resistant to microbial action so decomposes at slow rate and is rich in nutrients.
- (v) **Mineralisation** : Humus is further degraded by some microbes and release of inorganic nutrients occurs.

## CHAPTER 15

---

# BIODIVERSITY AND CONSERVATION

---

---

### POINTS TO REMEMBER

---

**Biodiversity** : Term used to describe diversity at all levels of biological organisation. Term coined by socio-biologist Edward Wilson and was also used by Walter G Rosen for the diversity of life forms. Biodiversity refers to totality of genes in species and ecosystems of a region.

**Three inter-related levels of Biodiversity** : Genetic diversity, Species diversity, Ecological diversity.

- ♦ **Genetic diversity** : Diversity in the number and types of genes, as well as chromosomes present in different species and the variations in the genes and their alleles in the same species. It helps in speciation.
- ♦ **Species diversity** : Varieties in the number and richness of the species of a region.
- ♦ **Ecological diversity** : Variety in the types of ecosystems.

**IUCN** : International Union for Conservation of Nature and Natural Resources. Its situated in Morges, Switzerland.

**India has** : More than 50,000 genetically different varieties of rice; 1000 varieties of mango;

- ♦ India has 1,42,000 known species of plants and animals (Around 45,000 species of plants and rest of animals);
- ♦ India has 8.1% of share of global biodiversity.
- ♦ India is one of **12 Mega diversity** countries of the world.

#### **Latitudinal Gradients**

- ♦ In general, species diversity decreases as we move away from the equator towards the poles.
- ♦ With very few exceptions, tropics (latitudinal range of 23.5° N to 23.5°S) harbour more species than temperate or polar areas.
- ♦ Colombia located near the equator has nearly 1,4000 species of birds while New York at 41° N has 105 species and Greenland at 71° N only 56 species.
- ♦ India has more than 1,200 species of birds.
- ♦ A forest in a tropical region like Equador has up to 10 times as many species of vascular plants as a forest of equal area in a temperate region like the Midwest of the USA.

- ♦ The largely tropical Amazonian rain forest in South America has the greatest biodiversity on earth.

### **Species-Area relationships**

- ♦ German naturalist and geographer Alexander von Humboldt observed that within a region species richness increased with increasing explored area, but only up to a limit.
- ♦ The relation between species richness and area for a wide variety of taxa (angiosperm plants, birds, bats, freshwater fishes) turns out to be a rectangular hyperbola.
- ♦ On a logarithmic scale, the relationship is a straight line described by the equation

$$\log S = \log C + Z \log A$$

Where S = Species richness, A = Area; Z = slope of the line (regression coefficient)

C = Y – intercept.

- ♦ Value of Z lies in the range of 0.1 to 0.2, regardless of the taxonomic group or the region.
- ♦ The species-area relationships among very large areas like the entire continents has much steeper slope of the line (Z values in the range of 0.6 to 1.2).

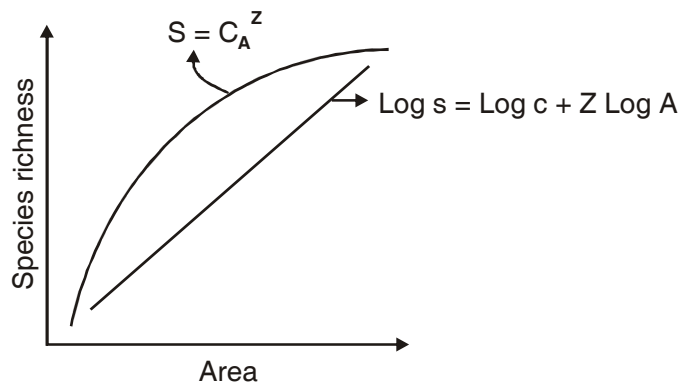

### **Causes of Biodiversity Losses**

1. **Habitat loss and fragmentation** : This is most important cause of plants and animals extinction. *For example* : Tropical rain forest being destroyed fast. The Amazonian rain forest is called the 'lungs of the planet'. It is being cut for cultivating soyabeans.
2. **Over-Exploitation** : Many species extinctions are due to over exploitation by humans.
3. **Alien Species Invasions** : When alien species are introduced some of them turn invasive and cause decline or extinction of indigenous species.
4. **Co-extinctions** : When a species becomes extinct, the plant and animal species associated with it in an obligating way also become extinct.

### **Reasons for Conservation of Biodiversity**

1. **Narrowly utilitarian** : Humans derive countless direct economic benefit from nature food (cereals, pulses, fruits), firewood, fibre, construction material, industrial products (tannins, lubricants, dyes,

resins, perfumes) and products of medicinal importance.

2. **Broadly utilitarian** : Biodiversity plays a major role in many ecosystem services that nature provides.
3. **Ethical** : every species has an intrinsic value, even if it may not be of any current economic value to us. We have a moral duty to care for their well-being and pass on our biological legacy in good order to future generations.

### **Types of Conservation Strategies**

**In-situ conservation** : Conservation and protection of the whole ecosystem and its biodiversity at all levels in order to protect the threatened species. Endangered species protected in natural conditions.

- ♦ **Sacred Groves** : Tracts of forest are set aside and all the trees and wildlife within are venerated and given total protection. *E.g.*, some forest in Khasi and Jaintia hills.
- ♦ **Hot Spots** : Areas with high density of biodiversity or mega diversity. *E.g.*, Out of 34 hot spots in world, 3 occur in India. *i.e.*, *Western Ghats and Sri Lanka, Indo-Burma (North-East India) and Himalaya.*
- ♦ **Protected Areas** : Ecological or Biogeographical areas where biological diversity with natural and cultural resources are protected. *E.g.*, National parks, sanctuaries and Biosphere reserves.

**Ex-situ conservation** : Conservation and protection of selected rare plants or animals in places outside their natural homes.

- ♦ **Offsite collections** : Live collections of wild and domesticated species in Botanical gardens, Zoological parks etc.
- ♦ **Gene Banks** : Institutes which maintain stock of viable seeds, live growing plants, tissue culture and frozen germplasm with the whole range of genetic variability.

**Cryopreservation** : Preservation of seeds, embryos etc. at  $-196^{\circ}\text{C}$  in liquid nitrogen.

**Co-extinction** : Extinction of a species can cause extinction of plants and species associated with it.

**National Parks** : Areas reserved for wild life where they are able to obtain all the required natural resources and proper habitats. India has 89 national parks at present.

**Sanctuaries** : Tracts of land with or without lake where animals are protected from all types of exploitation and habitat disturbance. India has 492 sanctuaries at present.

**Biosphere Reserves** : Large tracts of protected land with multiple use preserving the genetic diversity of the representative ecosystem by protecting wild life, traditional life styles of the tribals and varied plant and animal genetic resources. India has 14 biosphere reserves.

**Red Data Book** : Record of threatened species of plants and animals maintained by IUCN.

### **Important Wild Life Projects in India :**

- ♦ **Project tiger** : Started in 1973 to check depletion in population of tiger. Jim Corbett National

Park.

**Biodiversity Hotspots** : Regions of high endemism and high level of species richness.

**Endemic Species** : Species which are confined to a particular region and not found anywhere else.

**Exotic or Aliens Species** : New species which enter a geographical regions.

**Bio prospecting** : Exploration of molecular, genetic and species level diversity for products of economic importance.

**International Efforts for Biodiversity Conservation :**

- ♦ **World Conservation Union (formerly IUCN)** : provides leadership, common approach and expertise in the area of conservation.
- ♦ **The Earth Summit** : Historical convention on Biological diversity held in 1992 at Rio de Janeiro, Brazil.
- ♦ **The World Summit on Sustainable Development** : Held in 2002 in Johannesburg, South Africa to pledge to reduce biodiversity losses at global and local levels.

## QUESTIONS

---

### VSA (I MARK)

1. Habitat loss and fragmentation has caused severe damage to a particular type of ecosystem. Name it.
2. What trend is observed in respect of species diversity when we move from equator to poles?
3. Which region is considered as the one with highest biodiversity on earth? What is the name given to such region. forests?
4. Ecologists have discovered that value of 'Z' lies in range of 0.1 to 0.2 regardless of taxonomic group or region. When will the slope of line steeper in species area relationship?
5. Define cryopreservation. Why is it useful in conserving biodiversity?

### SA - II (2 MARKS)

6. How many species of plants and animals have been described by IUCN in 2004? What is global species diversity according to Robert May?
7. Explain co-extinction with a suitable example.
8. Study the pie-diagram and answer the questions which follows :  
What do A, B, C and D represent in these diagrams.

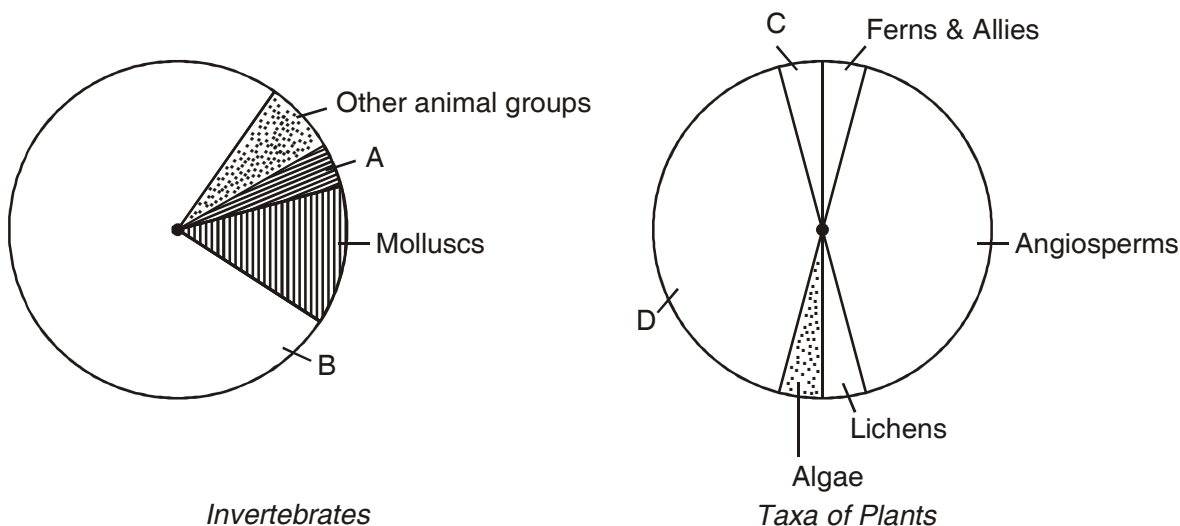

**SA I (3 MARKS)**

- Hot spots are the regions of exceptionally high biodiversity. But they have become regions of accidental habitat loss too. Name the three hot spots of our country. Why are they called 'Hot spot'?
- Study the diagram of the earth given below. Give the name of the pattern of biodiversity therein. Suggest any two reasons for this type of occurrence.

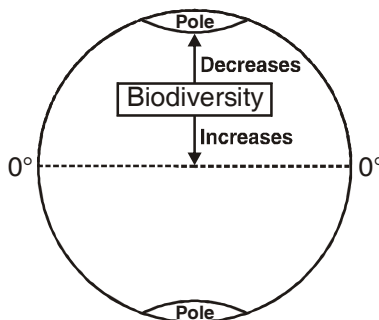

**LA - (5 MARKS)**

- Why is the sobriquet 'The Evil Quartet' used in context of biodiversity? Name the members of this quartet. Why do we grieve for the genes when a species is lost?
- Describe at least two approaches each for ex-situ conservation and in situ conservation as a strategy for biodiversity conservation.

**ANSWERS**

**VSA (1 MARK)**

- Tropical Rain Forest.
- In general, species diversity decreases as we move away from the equator towards poles.





- (v) We grieve for the loss of genes, because the wild forms are hardy and more resistant to pathogen attack and can be beneficial in crop breeding programmes.

12. **In situ conservation :**

- (i) Identification and maximum protection of 'hot spots'
- (ii) Legal protection to ecologically rich areas.
- (iii) Biosphere reserves, national parks and sanctuaries
- (iv) Sacred groves.

**Ex situ Conservation :**

- (i) Creation of zoological parks, botanical garden, wild life sanctuary
- (ii) Cryopreservation
- (iii) Seed bank.

## CHAPTER 16

# ENVIRONMENTAL ISSUES

### POINTS TO REMEMBER

**Pollution** : Undesirable physical/chemical/biological characteristics of air/water/land which cause damage to the animals/plants/humans and architectural structures.

**Pollutants** : Agents which cause pollution.

**Slash and Burn Agriculture (Jhum Cultivation)** : Farmers cut down trees and burn the plant remains. Ash is used as a fertiliser and the land is then used for farming or cattle grazing.

**Reforestation** : Process of restoring a forest that was removed at some point of time in the past.

**Effluents** : Something flowing over a large body of water (may be sewage or industrial effluents).

**CPCB** : Central Pollution Control Board

**BOD** : Biological Oxygen Demand

**CNG** : Compressed Natural Gas

**FOAM** : Friends of Arcata Marsh

**JFM** : Joint Forest Management.

### Biochemical Oxygen Demand (BOD)

- ♦ BOD refer to the amount of oxygen that would be consumed if all the organic matter in one litre of water were oxidized by bacteria. The BOD test measures the rate of uptake of oxygen by micro-organisms in a sample of water.
- ♦ Indirectly BOD is a measure of the organic matter present in the water. The greater the BOD of waste water, more is the its polluting potential.
- ♦ In the given figure the effect of sewage on some important characteristic of a river is shown.

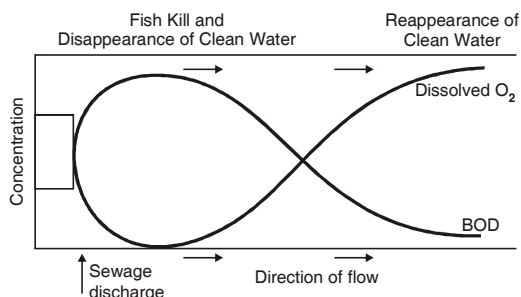

**Algal Bloom** : Presence of large amounts of nutrients in water causes excessive growth of algae, called an algal bloom.

Harmful effect of algal bloom are :

1. Fish mortality
2. Deterioration of water quality
3. Toxic to animals and human beings.

### **Biomagnifications**

- ♦ It refers to increase in concentration of toxic substances at successive trophic level.
- ♦ Biomagnifications of DDT in an aquatic food chain

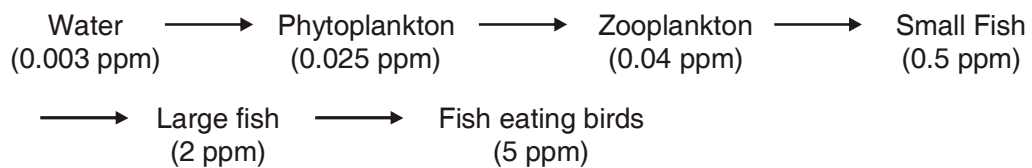

**Harmful Effect** : High concentration of DDT disturb calcium metabolism in birds, which causes thinning of egg shell and their premature breaking, causing decline in birds population.

**Eutrophication** : It the process of nutrient enrichment of water and subsequent loss of species diversity like fishes. Excess nutrients causes algal bloom which may cover the whole water surface in water body and release toxins. It causes oxygen deficiency in water that leads to the death of aquatic animals like fishes.

**Global Warming** : Increase in the level of greenhouse gases is mainly responsible for global warming. (Increase in mean global temperature due to trapping of infrared radiation). Carbon dioxide, Methane, CFCs, N<sub>2</sub>O are the main gases that causes greenhouse effect.

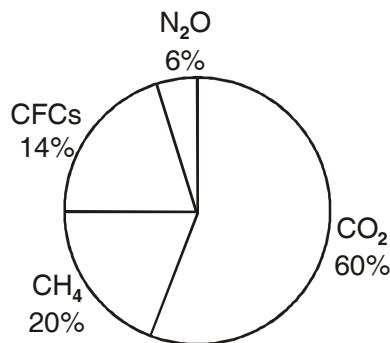

Harmful effects of global warming :

1. Melting of glaciers
2. Over many years, this will result in a rise in sea level that can flood the population coaster plains.

### **Measures of Control Global Warming**

1. Minimise the use of fossil fuel.
2. Improving efficiency of energy usage.
3. Reducing deforestation.
4. Planting trees.

### **Ozone Depletion :**

- ♦ Ozone gas is continuously formed by the action of UV rays on molecular oxygen and also degraded into molecular oxygen in stratosphere.
- ♦ The thickness of the ozone-layer in a column of air from the ground to the top of the atmosphere is measured in terms of Dobson units (DU).
- ♦ Ozone layer absorbs the harmful UV rays. These rays cause the skin cancer, damages genes inflammation of cornea.
- ♦ Chlorofluro Carbons deplete the ozone layer. The part of atmosphere with lesser concentration of ozone is called ozone hole.

### **Steps leading to ozone depletion**

- ♦ UV rays split CFCs and release atomic (Cl)
- ♦ UV rays also split ozone into oxygen.
- ♦ Chlorine atoms trap oxygen atoms and ozone is not formed again from oxygen. This leads to depletion of ozone in the stratosphere.

**Ozone Hole :** Large area of thinned ozone layer over Antarctica.

**Control of Vehicular Air Pollution in Delhi :** All the buses of Delhi were converted to run on CNG by the end of the 2002. Other steps to reduce air pollution in Delhi include.

1. Phasing out of old vehicles.
2. Use of unleaded petrol and low sulphur petrol and diesel.
3. Use of catalytic converters in vehicles.
4. Application of Euro-II norms for vehicles.

**Auto Fuel Policy :** The Government of India has laid out a road map to cut down the vehicular air pollution in many cities of India. The goal of this policy is to reduce Sulphur to 50 ppm in petrol and diesel and reduce to 3.5% of the fuel. The Bharat Stage II will be applicable to all automobiles in all cities April, 1, 2005. The cities (like Delhi, Mumbai, Chennai, Kolkata etc.) will have to meet Euro III emission norm from April 1, 2005 and Euro IV Emission norm from April 1, 2010.

## QUESTIONS

---

### VSA (I MARK)

1. Why should the velocity of air between the plates of an electrostatic precipitator be low?
2. PM<sub>2.5</sub> is responsible for causing greatest harm to human health. What is it? How is it harmful?
3. What is the noise level that can cause permanent impairment of hearing ability of human beings?
4. Why was the Montreal Protocol signed?
5. Jhum cultivation has been in practice from earlier days, but its considered more problematic these days. Why?
6. A radiation causes ageing of skin, skin cancer, and inflammation of cornea called snow blindness. it also damages DNA. Name the radiation.

### SA – II (2 MARKS)

7. Electrostatic precipitator can remove over 99% particulate matter present in exhaust from a thermal power plant. How?
8. Why is a scrubber used? Which spray is used on exhaust gases passing through a scrubber?
9. There is a sharp decline in dissolved oxygen downstream from the point of sewage discharge. Why? What are its adverse effects?
10. Catalytic converters use expensive metals as catalysts.
  - (a) Name the metals generally used.
  - (b) What precaution should be observed while using catalytic converter.
11. What are e-wastes? Why are they creating more problem in developing countries in comparison to developed countries?
12. Water logging and salinity are some of the problems that have come in the wake of Green revolution. How does water logging create problems of salinity?

### SA – I (3 MARKS)

13. Deforestation is creating a lot of problems in the environment. List the consequences of deforestation.
14. Enlist four harmful effects caused to the humans living in polluted air. Suggest two measures to reduce air pollution.
15. People have been actively participating in the efforts for the conservation of forests.
  - (i) Name the award instituted in respect of Amrita Devi to promote such efforts.

- (ii) Name the movement launched to protect the trees by hugging them.
- (iii) Name the step Government of India has undertaken in 1980's to work closely with the local communities for protecting and managing forests.

### **LA – (5 MARKS)**

16. Pollutant from man's activities like effluents from industries and homes can radically accelerate the ageing process.
- (a) Explain how does this process occurs during natural ageing of lake.
  - (b) Give the term used for accelerated ageing of water bodies. Also give the term used for the natural ageing of lake.
17. In Arcata, the towns people have created an integrated waste water treatment process within a natural system. A citizen group called FOAM helps in upkeep of this project.
- (a) What are the main steps in waste water management done in this way?
  - (b) 'Ecosan' in Kerala and Sri Lanka is also an initiative for water conservation. How?

## **ANSWERS**

---

### **VSA (I MARK)**

1. To allow the dust to fall.
2. PM2.5 stands for particulate matter of size 2.5 micrometers or less in diameter. Its responsible for causing greatest harm to human health as it can be inhaled deep into lungs and cause breathing problems.
3. 150 dB or more
4. To control emission of ozone depleting substances.
5. Enough time gap is not being given for the natural process of recovery of land from the effect of cultivation.
6. Ultraviolet B rays (UV-B rays)

### **SA II (2 MARKS)**

7. Electrode wire at thousand volts, produce corona to release electrons, electrons attach to dust particules giving them net negative charge, charged dust particules attracted/collected by collecting plates which are grounded.
8. To remove gases like sulphur dioxide. Spray of water or lime is used.
9. Following discharge of sewage into river, micro organisms involved in biodegradation of organic matter present in sewage consume more oxygen. This cause mortality of fish and other aquatic creatures.

10. (a) Catalysts : platinum - palladium and Rhodium  
(b) Motor vehicles equipped with catalytic converters should use unleaded petrol as lead inactivates the catalysts.
11. (a) Irreparable computers and other electronic wastes.  
(b) Recycling in developing countries involves manual participation thus exposing workers to toxic substances. In developed countries its mechanised so less dangerous.
12. Water logging draws salt to surface of soil. Salt deposited on land surface as a thin crust or at the roots of the plants.

### **SAI (3 MARKS)**

13. ♦ Enchanged CO<sub>2</sub> concentration in atmosphere  
♦ Loss of biodiversity  
♦ Soil erosion  
♦ Desertification  
♦ Disturbed hydrological cycles.
14. Breathing problems, irritation and inflammation, Damage to lungs, Premature death.  
♦ Reduce emission of automobile exhaust  
♦ Growing more trees.
15. (i) Amrita Devi Bishnoi Wildlife Protection Award.  
(ii) Chipko movement  
(iii) Joint Forest Management (JFM).
16. (a) The phenomeon is eutrophication. More nutrients in water, aquatic life increases organic remains deposited on lake bottom, lake grows shallower and warmer, gradually transforms into land due to deposition of silt and organic debris.  
(b) Cultural or Accelerated eutrophication  
Natural ageing is Eutrophication.
17. (a) Conventional sedimentation, filtering and chlorine treatment. Absorption and assimilation of pollutants by algae fungi and bacteria.  
(b) 'Ecosan' derived from ecological sanitation. Handling human excreta using dry composting toilets. Its practical, hygienic and cost effective method.

---

## CLASS - XII

---

### MODEL PAPER – 1 (Unsolved)

---

#### BIOLOGY (THEORY)

---

Time : 3 hours

Maximum Marks : 70

**General Instructions :**

1. All questions are compulsory.
2. This question paper consists of four sections A, B, C and D. Section A contains questions of 1 mark each. Section B is of 10 questions of 2 marks each. Section C has 9 questions of 3 marks each, whereas section D is of 3 questions of 5 marks each.
3. There is no overall choice. However an internal choice has been provided in one question of 2 marks, one question of 3 marks and all the three questions of 5 marks weightage. A student has to attempt only one of the alternative in such questions.
4. Wherever necessary, the diagrams drawn should be neat and properly labelled.

#### SECTION A

---

1. State competitive exclusion principle (Gause's principle).
2. Why. 'Asexual reproduction does not produce the genetic variability'?
3. Name the insecticidal protein which is produced by *Bacillus thuringiensis*.
4. Thorns of *Bougainvillea* and tendrils of *Cucurbita* are considered as homologous organs. Give reason.
5. Expand IUD and MTP.
6. Which category of adaptive immunity is provided by vaccination?
7. Why is male *Drosophila* fly referred to as heterogametic?
8. What is meant by juvenile phase of an organism?

#### SECTION B

---

9. Observe the following pie-chart showing contribution of green house gases to global warming. Name the gases denoted as A and B.



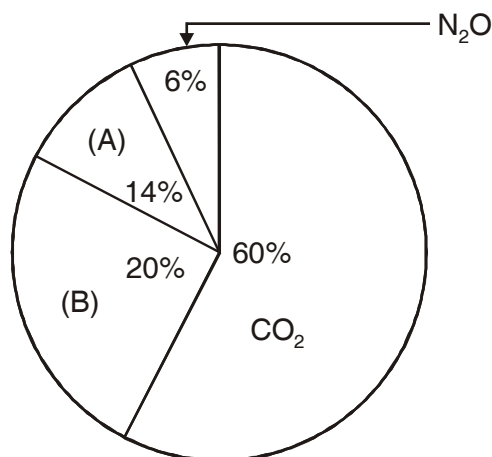

10. Mention two strategies evolved by flowers to prevent self pollination.
11. What would happen to the successive trophic level in the pyramid of energy, if the rate of reproduction of phytoplankton was slow down? Suggest two factors which could cause such a reduction in phytoplankton reproduction.
12. Frederick Giffith carried out his experiments on *Diplococcus pneumoniae* using R-Strains and S-Strains. What is meant by R-strains and S-Strains? What did he prove from these experiments.
13. List any four factors which may lead to loss of biodiversity.
14. Differentiate between convergent and divergent evolution.
15. What is single cell protein? What is the significance of such a protein?
16. Name the endocrine structure found in empty Graafian follicle. What role does it play during pregnancy?
17. What does S-Shaped pattern of population growth represent? How is J-shaped pattern different from it and why?

**OR**

What type of conservation measures, *in situ* or *ex situ* will help the larger number of species to survive? Explain.

18. Fill in the blanks A, B, C and D in the following tables

S. No.	Methods of birth Control	Contraceptive/device
1.	Natural	A
2.	B	Vasectomy
3.	C	Saheli
4.	Implants	D

## SECTION C

19. The following figure represents rDNA technology. Observe the figure and give answer of the questions given below :

- (a) Identify A, B, C and D      (b) Write two applications of this technique.

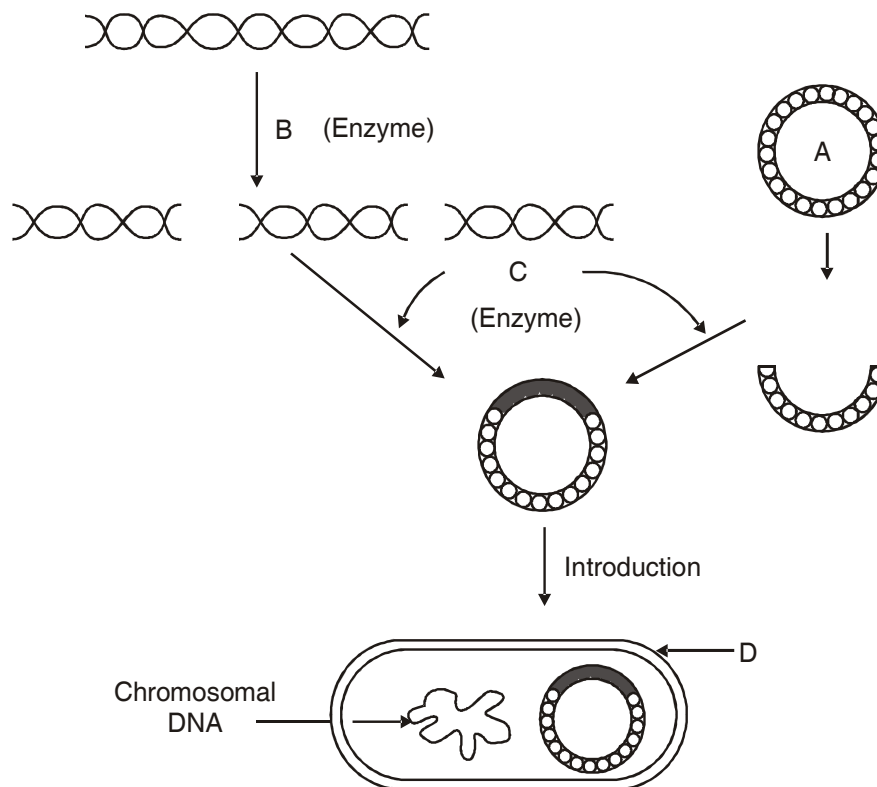

20. In snapdragon (*Antirrhinum majus*) a plant with red flowers was crossed with a plant with white flowers. Work out all the possible genotypes and phenotypes of  $F_1$  and  $F_2$  generations. Comment on the pattern of inheritance in this case.
21. Describe various steps involved in the treatment of sewage before it is discharged into a water body like a river.
22. With the help of a labelled diagram, explain the typical structure of female gametophyte of an angiosperm.
23. What is an operon? Who first proposed this concept? Describe the major steps involved in *lac* operon.
24. A sperm has just fertilised a human egg in the fallopian tube. Trace the events that the fertilised egg will undergo upto the implantation of the blastocyst in the uterus.

**OR**

Briefly describe the stages of spermatogenesis in humans.

25. Describe how nematode resistant transgenic plants have been produced.

26. How did Urey and Miller prove the abiotic synthesis of organic molecules that must have been formed on the primitive earth? Name any two such molecules obtained?
27. Represent diagrammatically the *E. Coli* cloning vector pBR 322.

## SECTION D

---

28. (i) What are allergens? Give an example.
- (ii) Write two common symptoms of allergy.
- (iii) Write the full name of the organism that causes AIDS. Mention the category of people who are at high risk of getting this disease.

OR

- (i) What is a protoplast?
- (ii) Name the two enzymes used in producing protoplasts.
- (iii) Describe the steps in producing somatic hybrids from protoplasts.
- (iv) Mention the usefulness of somatic hybridisation.
29. (i) Represent the change of base (point mutation) that causes sickle cell anaemia. Represent diagrammatically the Hb<sup>A</sup> and Hb<sup>S</sup> polypeptides.
- (ii) Write two symptoms exhibited by Turner's syndrome sufferer. Explain the cause of this disorder.

OR

Describe in detail the steps involved in the technique of DNA fingerprinting.

30. (i) Define decomposition and describe the process of decomposition.
- (ii) Draw schematically the phosphorus cycle in nature.

OR

- (i) Describe in detail the species area relationship of biodiversity.
- (ii) The Amazonian rain forest in South America has the greatest biodiversity on earth sustainable with numbers of different species of organisms. Give reasons.

---

## CLASS - XII

---

# BIOLOGY (Solved)

---

Time allowed : 3½ hours

Maximum marks : 70

### **General Instructions**

1. All questions are compulsory.
2. This question paper consists of four Sections A, B, C and D. Section A contains 8 questions of one mark each, Section B is of 10 questions of two marks each, Section C is of 9 questions of three marks each and Section D is of 3 questions of five marks each.
3. There is no overall choice. However, an internal choice has been provided in one question of 2 marks, one question of 3 marks and all the three questions of 5 marks weightage. A student has to attempt only one of the alternatives in such questions.
4. Wherever necessary, the diagrams drawn should be neat and properly labeled.

### **SECTION A**

1. When does an oocyte complete oogenesis? When does oogenesis begin in a human female?
2. Which organisms are usually the pioneer species in a (i) Hydrarch and (ii) Xerarch succession?
3. Give an example to show how the same species can occupy more than one trophic level in the same ecosystem.
4. Cucurbits and coconut bear unisexual flowers but are monoecious. Why?
5. Define allelomorphs.
6. DNA in chromosomes also replicates semi-conservatively. How did Taylor and colleagues prove it?
7. Besides converting the milk to curd, which are the two other roles played by LAB?
8. What are baculoviruses?

### **SECTION B**

9. (i) Very small animals like shrews and humming birds are rarely found in Polar Regions. Why?  
(ii) Define Diapause.

10. Read the graph given below and correlate the uterine events that take place according to the hormonal levels on
- 6-15 days
  - 16-25 days
  - 26-28 days (if ovum is not fertilized)

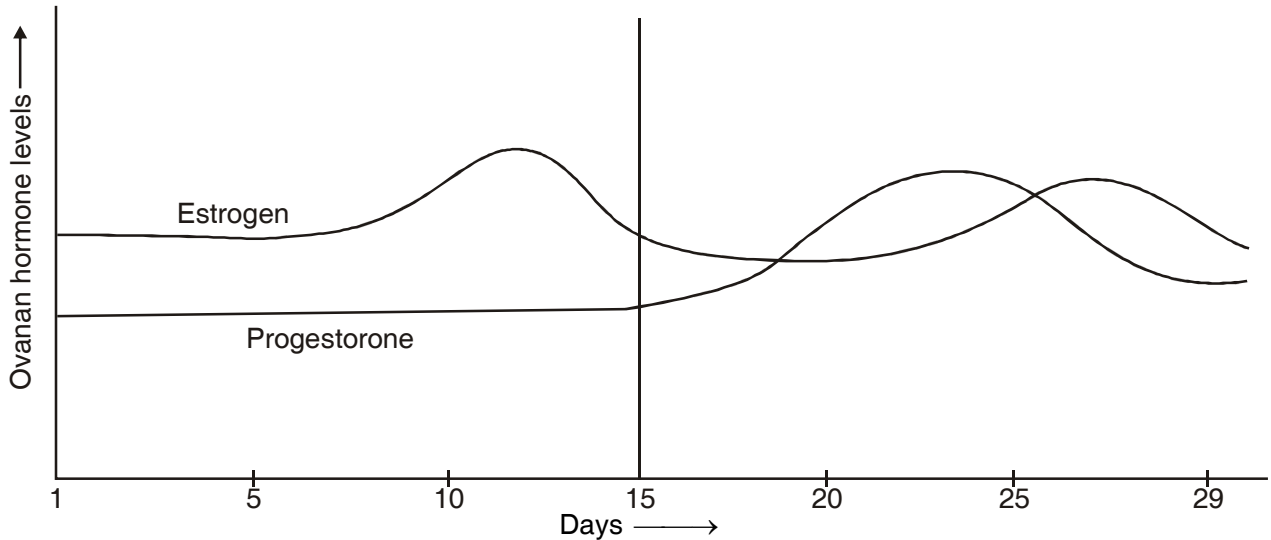

11. Draw the structure of initiator t-RNA molecule. Why is t-RNA called as an adapter molecule?

**OR**

Lactose plays a dual role in the *lac*-operon. How? Why is *lac*-operon said to be under negative regulation?

12. (a) The graph below represents the growth patterns of two types of aquatic organisms over a brief period of time in a water body surrounded by an agricultural land extensively supplied with fertilisers. Identify the organisms that would represent (i) A and (ii) B.
- (b) State the reason for such a change in the water body and also write the term given to it.

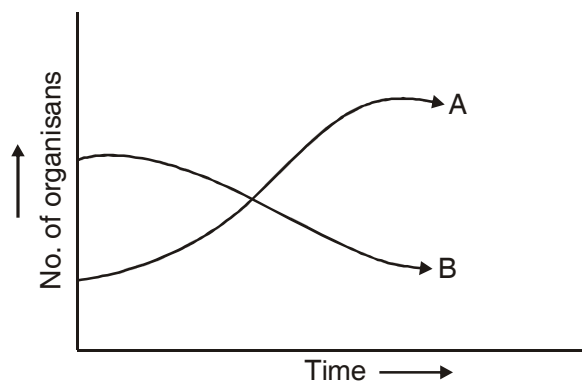

13. How do Cu 7 or Multiload 375 and Progestasert or LNG-20 differ in their contraceptive action?
14. Inbreeding is necessary and useful in some cases. How? Name the problem which can be caused due to close inbreeding and the way to get rid of the problem.
15.  $\alpha$ -Interferons are helpful in controlling a very fetal disease. Name the disease and ways to detect it. How do the  $\alpha$ -interferons help in such cases?
16. How is a divalent cation like Calcium useful in making the host cell competent for transformation with rDNA? What is biolistics?
17. Approval of which organization is needed for getting a clearance for mass production of a genetically modified organism? What can be the any two possible reasons for the need of such organization?
18. IgE antibodies are usually produced in response to certain substances. What are such substances called? What is the condition caused due to such substance and mention the cell and its chemical which causes such condition?

### SECTION C

19. An ecologist wants to explore an area with a higher biodiversity. Suggest whether he/she should explore a tropical region or a temperate region? Why?
20. Million of gamete mother cells have been formed in the fetal ovary of a human female. Trace the events which will follow till the formation of mature female gamete (Ovum).
21. Explain with a suitable example the phenomenon of incomplete dominance.
22. Draw the schematic structure of a transcription unit. What is the convention in defining the two strands of DNA in such case? What will be the bases in the coding strand if template strand reads 3'-ATGCATGCATGCATGCATGC-5'?
23. Using algebraic equations prove that the frequency of occurrence of alleles of a gene or a locus is fixed and remain same for generations in a given population. Who proposed this? What factors effect it?
24. Explain the working of Sewage treatment plants and define primary sludge, flocs and activated sludge.
25. With the help of a flow chart show the multiplication of a retrovirus which can cuase a deficiency of immune system which is acquired during life time of an organism.
26. Write the missing steps in the following flowchart :

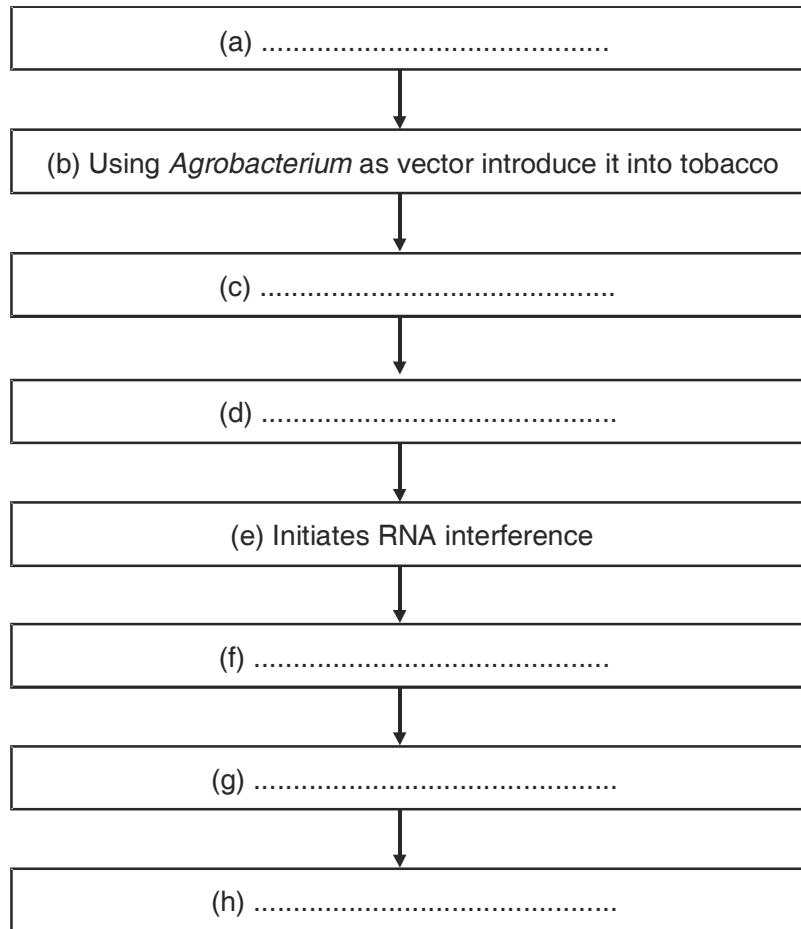

**OR**

What are the features of cloning vectors? How will you distinguish recombinants from non-recombinants?

27. Explain with reference to PCR

- (a) A specific enzyme helps in amplification in PCR. Name the bacterium from which it is isolated and state how its thermostable nature is helpful.
- (b) Explain its use in molecular diagnosis

### **SECTION D**

28. Domestic and sewage effluents can cause algal bloom, biomagnification, eutrophication. How? What effect does it have on BOD? What is cultural eutrophication?

**OR**

How is the “sixth episode of extinction” of species on earth, now currently in progress, different from the five earlier episodes? What is it due to? Explain the various causes that have brought about this difference.

29. (a) Explain the process of megasporogenesis.  
 (b) Name any three outbreeding devices. What is self incompatibility?

**OR**

Show diagrammatically the stages of embryonic development from zygote upto implantation in humans.

30. (a) Show diagrammatically the results of dihybrid cross carried out by T.H. Morgan to show linkage.  
 (b) What is pedigree analysis and its use? What will be the genotype of each of the individuals in the following pedigree chart :

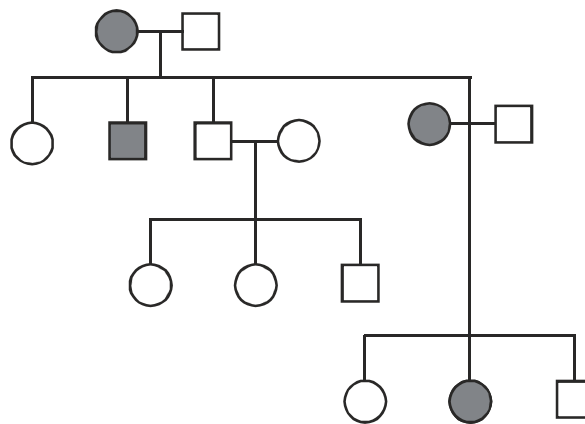

**OR**

- (a) Explain the technique in which VNTRs can be used in ascertaining the genetic diversities.  
 (b) What are the differences between prokaryotic and eukaryotic transcription?



---

# SAMPLE PAPER (SOLVED)

---

## ANSWERS

---

### SECTION A

1. Oogenesis completed when sperm comes in contact with zona pellucida of ovum. Oogenesis is initiated during embryonic development.
2. **Hydrarch Succession** : Usually small phytoplanktons.  
**Xerarch Succession** : Usually lichens.
3. Sparrow is primary consumer when eats seeds and secondary consumer when it eats worms.
4. They are Monoecious as both male and female flowers occur on same plant.
5. **Allelomorphs** : Various or slightly different forms of a gene having same position on chromosome.
6. Used radioactive thymidine on DNA of chromosomes in *Vicia faba*.
7. (i) Improves nutritional quality by increasing vitamin B<sub>12</sub>  
(ii) Check disease causing microbes.
8. **Baculoviruses** : Pathogens that attack insects and arthropods.

### SECTION B

9. They have large surface area relative to their volume so lose body heat very fast in colder regions. Hence, occur rarely in polar region.  
**Diapause** : A stage of suspended development shown by many zooplanktons in lakes and ponds.
10. (i) Regeneration of endometrium.  
(ii) Uterus gets high vascularised, ready for embryo implantation.  
(iii) Disintegration of endometrium.
- 11.

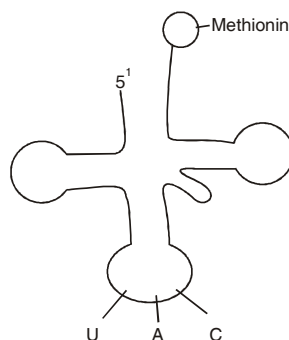

Adaptor molecule because

- (i) on one hand reads the code,
- (ii) on the other hand binds to specific amino acid.

**OR**

Lactose plays as inducer as well as substrate in the lac-operon. Lac-operon is under negative regulation as the presence of repressor prevents the transcription in the operon.

12. a (i) Water hyacinth/algal growth  
(ii) Fish/Aquatic animals.  
b (i) Excessive growth of algae triggered by nitrates and phosphates from agricultural land run off water.  
(ii) algal bloom/eutrophication

13. Cu7 and Multiload 375 → copper releasing IUD's  
Progestasert, LNG - 20 → hormone releasing IUD's

Both increase phagocytosis of sperm and affect sperm motility. Hormone releasing also make uterus unsuitable for implantation and cervix hostile to the sperms.

14. Inbreeding  
(i) increases homozygosity, so helps in creating pure lines,  
(ii) exposes lethal genes.

**Problem Caused** : Inbreeding depression.

**Remedy** : Mating with unrelated superior animals of the same breed.

15. **Disease** : Cancer

**Ways to Detect** : Biopsy, MRI, Radiography, CT  $\alpha$ -interferons activate immune system and helps in destroying the tumor.

16. Divalent cations increases efficiency with which DNA enters the bacterium through pores in its cell wall.

**Biolistics** : Bombarding the cells with high velocity micro particles of gold or tungsten coated DNA.

17. **GEAC** : Genetic, Engineering, Approval committee

- to check validity of GM research,
- to ensure safety of introducing GM organisms for public services.

18. IgE are produced against allergens.

Condition is called allergy.

Mast cells cause the allergic response by secreting histamine and serotonin.

## SECTION C

19. He should explore tropical region because tropical regions have higher diversity due to :
- More speciations as remained undisturbed for millions of year.
  - Less seasonal so more niche specialisation for species.
  - More solar energy so more productivity.
20. Refer figure 3.8(b), NCERT-Bio text book class XII on page no. 49.
21. Refer Page 76 NCERT–Bio Text Book

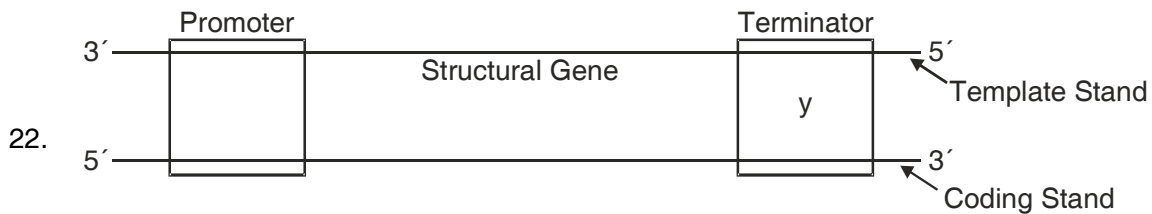

**Convention :** All reference point while defining a transcription unit is made with respect to coding strand. Promoter region is towards 5' end of coding strand.

Coding Strand 5' TACGTACGTACGTACGTACG 3'

23. Sum total of all allelic frequencies is one.
- Let  $p$  and  $q$  represent the frequency of alleles  $A$  and alleles ' $a$ ' respectively. So  $p + q = 1$ . for a monohybrid cross, the frequency of  $AA$  is  $p^2$  and ' $aa$ ' is  $q^2$  and that of  $Aa$  is  $2pq$ .
- Hence,  $p^2 + 2pq + q^2 = 1$
- This is a binomial expansion of  $(p + q)^2$
- i.e.* it remains constant at 1.
- This was proposed by Hardy and Weinberg.
  - Gene flow, genetic drift, mutation, genetic recombination and natural selection effect it.
24. Refer page 184, NCERT - Biology Class XII.
25. Refer fig 8.6, page 155, NCERT - Biology Class XII.
26. (a) Isolate nematode specific genes.  
(b) Produces sense and anti sense RNA in host cells.  
(c) Forms double stranded RNA (due to being complementary).  
(d) Silence the specific mRNA of the nematode.  
(e) Transgenic tobacco plant is protected against nematode.

OR

- **Features of Cloning Vectors**

- (a) Ori site
- (b) Selectable marker
- (c) Cloning sites.

- Recombinant and non-recombinants can be distinguished by using insertional inactivation method in which recombinant DNA is inserted in coding sequence of an enzyme  $\beta$ -galactosidase.

This results into inactivation of the enzyme. Presence of chromogenic substrate gives blue coloured colony if plasmid does not have an insert but no colour is produced if insert there (as  $\beta$ -galactosidase becomes inactivated).

27. (a) Taq Polymerase obtained from bacterium called as *Thermus aquaticus*.
- (b) Very low concentration of bacteria or virus can be detected by amplifications of their nucleic acid by PCR.

### SECTION D

28.
  - Refer page 276, NCERT - Class XII, Biology.
  - It increases the BOD of water.
  - Human activities have accelerated the rate of eutrophication. This is called cultural eutrophication.

### OR

- Its occurring at a faster rate.
- Its due to human activities.
- Causes are
  - (i) Habital loss and fragmentation
  - (ii) Over exploitation.
  - (iii) Alien species invasions.
  - (iv) Co-extinctions

Refer page 264, NCERT-Bio Class XII

29.
  - Refer page 25-27, Class XII-NCERT (Biology).
  - Three outbreeding devices
    - (a) Pollen release and stigma receptivity are not synchronised.
    - (b) Anther and stigma are placed at different position.
    - (c) Self-incompatibility.

**Self-Incompatibility** : Genetic mechanism which prevents self pollen from fertilising the ovule by inhibiting pollen germination or pollen tube growth in the pistil.

**OR**

Refer Fig 3.11, page 52, NCERT-Biology Class XII.

30. (a) Refer Fig. 5.11. page 84-Biology Class XII  
(b) Analysis of traits in several of generations of a family is pedigree analysis.

Use : To trace inheritance of a specific trait, abnormality or diseases.

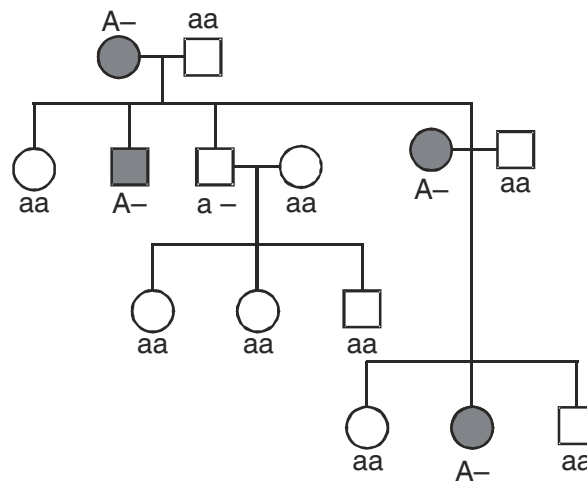

**Or**

- (a) The process/technique is DNA fingerprinting (Refer page No. 122, NCERT-Biology Class XII).  
(b) Refer page No. 110-111, NCERT-Biology, Class XII.