

BECKHOFF

PCcontrol

The New Automation Technology Magazine

Packaging Special 2014

www.pc-control.net

PACKAGING SPECIAL

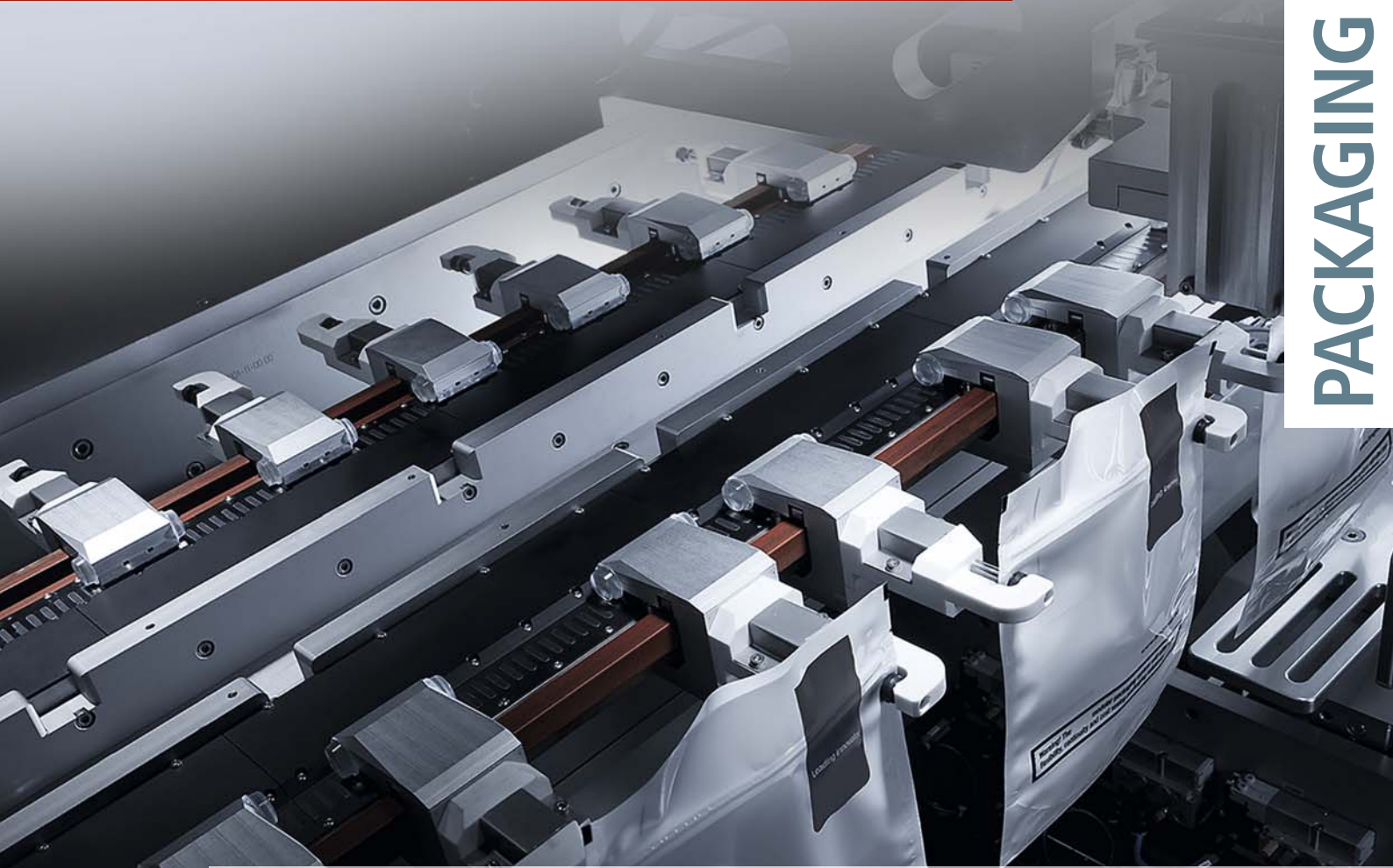

18 | cover

XTS revolutionizes machine design in the packaging industry



22 | worldwide

MULTIVAC: TwinCAT robot kinematics and servo drive technology promote efficiency in food packaging



34 | worldwide

Bosch Packaging: PC- and EtherCAT-based control improve performance and flexibility



5

PC Control drives innovation in packaging machine design



14

XTS: Software replaces mechanical components while adding functionality and flexibility

26

KOCH Pac-System: Modular control technology for compact packaging lines, including in cleanrooms



46

Galdi: Twelve-thousand cartons filled with fresh milk per hour

4 | editorial

Frank Würthner: Sustainability and resource efficiency are shaping the future of packaging technology

5 | interview

PC Control drives innovation in packaging machine design

14 | products

XTS: Software replaces mechanical components while adding functionality and flexibility

18 | cover

Technical Development Corporation, the Netherlands: Implementation of one of the first applications based on the eXtended Transport System (XTS)

22 | worldwide

MULTIVAC Sepp Haggenmüller, Germany: TwinCAT robot kinematics and servo drive technology promote efficiency in food packaging

26 | KOCH Pac-Systeme, Germany: Interview with Jürgen Welker on the design requirements of special machines for the packaging industry

30 | TVI Entwicklung & Produktion, Germany: Automating meat processing centers to be more flexible and precise

34 | Bosch Packaging, USA: PC- and EtherCAT-based control improve the performance and flexibility of packaging machines

38 | Matrix Packaging, USA: AM8000 servo motors with One Cable Technology save cabinet space and reduce costs

41 | Edson Packaging, Canada: Multi-touch panels enable intuitive operating concepts for packaging machines

44 | interview

The packaging industry is characterized by customized machine designs

46 | worldwide

Galdi, Italy: PC-based control meets all requirements for modular packaging machines

50 | Rohrer, Switzerland: Integrated PC-based control solution powers blister packaging machine for the pharmaceutical industry

54 | Eco-Dex, France: Automated medication management in hospitals

56 | Foshan Yinghui Packaging, China: Shrink film packaging machine for PET and glass bottles

58 | Further references from the global packaging industry

imprint

PC Control –
The New Automation Technology Magazine

Published:
Beckhoff Automation GmbH
Eiserstraße 5
33415 Verl/Germany
Phone: +49 (0) 52 46 9 63-0
Fax: +49 (0) 52 46 9 63 -1 98
info@beckhoff.com
www.beckhoff.com

Editor-in-Chief:
Frank Metzner

Project management:
Martina Fallmann

Editors:
Gabriele Kerkhoff
Stefan Ziegler
Phone: +49 (0) 52 46 9 63 - 1 40
Fax: +49 (0) 52 46 9 63 - 1 99
editorial@pc-control.net
www.pc-control.net

Picture Proof:
Bosch Packaging Technology Inc. USA
Edson Packaging Machinery Ltd, Canada
Eco-Dex, France
Galdi S.r.l., Italy
KOCH Pac-Systeme GmbH, Germany
Matrix Packaging Machinery, LLC, USA
MULTIVAC Sepp Haggenmüller GmbH & Co. KG, Germany
Technical Development Corporation, Netherlands
TVI Entwicklung & Produktion GmbH, Germany

Graphic Design: www.a3plus.de

Printed by: Richter Druck- und
Mediencenter, Germany

Circulation: 12,000



Frank Würthner, Business Management
Packaging, Beckhoff

Sustainability and resource efficiency are shaping the future of packaging technology

According to the National Geographic Society, Earth's population will increase by another billion people over the next 15 years, which means that the challenge to provide this many people with life's necessities will be huge, as will the demand to meet increases in the standards of living as economies develop. Packaging technology plays a significant role in this endeavor, because it ensures that all goods arrive at their destination undamaged and in hygienically safe condition.

Hygienically packaged consumer goods are a prerequisite for health and safety

Particularly in countries where the infrastructure for even basic necessities like water, food and medicine leaves a lot to be desired, better goods packaging can make a significant contribution to raising people's standard of living. For goods that must travel over long distances in difficult climatic conditions, modern, high-quality packaging is essential to ensure that products arrive safely and in good hygienic condition.

As a result, packaging technologies and materials are essential to assure cleanliness and hygiene even in the world's poorest regions. Considering the rapidly-growing world population, the packaging industry must tackle extra challenges as well. Although modern packaging machines can already perform feats that were nearly impossible not long ago, process workflows still harbor plenty of potential to combine high product quality and production efficiency with sustainability and resource conservation.

Powerful control technology drives innovation

Handling resources in a responsible manner is particularly important for the packaging industry, with its intensive use of energy and materials. To maximize the existing potential, all components of the process must be seamlessly integrated in order to create solutions for higher sustainability.

The starting point for packaging solutions that are efficient across their entire lifecycle, from production to shipping to recycling, is the engineering of the machine, which is supported by powerful control and drive technologies. While packaging technology requirements may differ between industries such as consumer goods, food and pharmaceuticals, what they all have in common is the need for better, more flexible, and most of all, more resource-efficient packaging solutions. PC Control is the ideal way to meet this demand for maximum sustainability with lower costs. For example, packaging machine manufacturers can employ eXtreme Fast Control (XFC) technology to implement process sequences with extreme precision, thus minimizing the use of resources such as the foil needed to seal blister packs, for example. Considering the huge quantities of materials involved in an entire production facility, the savings can be immense.

PC Control also supports the issue of process optimization, which has recently moved to the forefront in connection with the "Industry 4.0" campaign for Smart Factories. With its openness towards modern information technologies and consistent communication capabilities up to the ERP level and across company borders, Industry 4.0 makes the engineering and operation of such machines much more efficient. As a result, the packaging machine can be an important part of Industry 4.0-based production processes today with minimized energy and production costs thanks to integrated power management and condition monitoring.

Automation and motion control solutions for the packaging industry

PC Control drives innovation in packaging machine design

With PC-based control and EtherCAT technology from Beckhoff you can manage and monitor the entire packaging process, from individual packaging machines to complete packaging lines. Michael Jost, Roland van Mark, Michael Pfister, Uwe Prüßmeier and Frank Würthner – all Beckhoff experts in the field – explain from various perspectives the role PC Control plays as a driver of innovation for the design of packaging machines.



PC Control from Beckhoff offers a complete automation solution for all packaging tasks, from forming, filling and sealing to collecting, boxing, labeling and palletizing.



What are the most important current requirements in the packaging industry, and how do they affect the world's machine builders?

Frank Würthner: Packaging technology requirements vary from industry to industry. For example, the needs in the consumer goods industry are different from those in the food or pharmaceutical industries. What they all have in common, however, is an increased focus on quality, flexibility, and most of all, resource efficiency. In particular, the packaging machine industry must accommodate the trend to minimize the use of raw materials and other resources, which means delivering maximum sustainability and reduced manufacturing costs. The best way to do this is with eXtreme Fast Control (XFC) technology from Beckhoff, which, as the name implies, can implement process sequences with extreme speed and precision. When sealing blister packs, for example, XFC helps users minimize the consumption of plastic film, which can lead to significant cost savings considering the large quantities involved. At the end of the day, PC Control opens the door to many potential innovations and new ways forward in machine design. This is due in large part to the high performance of PC-based control technology and the openness of TwinCAT towards established IT tools and high-level programming languages as well as the integration of measurement and simulation technologies. PC Control is particularly well-suited for applications where products must be packaged at very high speeds or applications that involve complex motion control interactions. Additional safety benefits are provided by the fully integrated TwinSAFE solution, ranging from the TwinCAT Safety Editor and Safety-over-EtherCAT to TwinSAFE terminals and drive-integrated safety technology.



Frank Würthner, Business Management
Packaging, Beckhoff:

"PC-based control technology provides the ideal foundation for high-performing, flexible and resource-conserving packaging processes."

Quality management and traceability are becoming more and more important, particularly in the food and pharma industries. How does this affect the machines and automation technologies in general?

Frank Würthner: "Good manufacturing practice" (GMP) is the key. Needless to say, any packaging machine must make it possible to properly manage quality and workflows in accordance with GMP guidelines. Our TwinCAT automation software provides the best possible support for this approach with features like the TwinCAT Database Server which facilitates communication with all relevant databases.

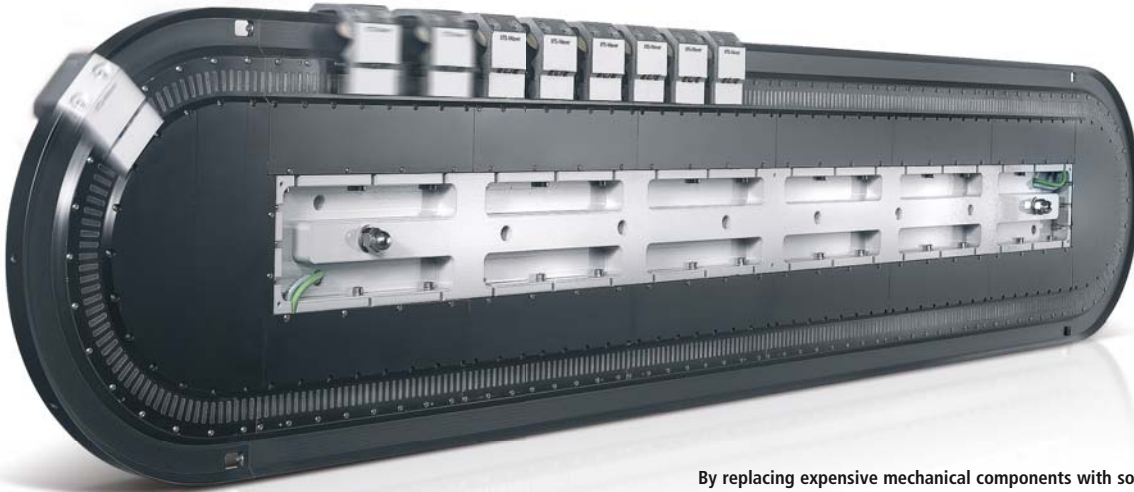

By replacing expensive mechanical components with software functionality, the eXtended Transport System (XTS) opens the door to new capabilities in packaging machine design.

A completely new approach is the eXtended Transport System (XTS), which combines the benefits of rotary and linear drive principles in a single system. What does this entail for packaging machines?

Uwe Průbmeier: Where rotary systems hit a wall previously, XTS now adds the properties of a linear drive system, thus opening the door to a new world of solutions for highly dynamic machine concepts. Particularly in the packaging industry, the combination of clocked processing with continuous flow delivers great benefits. With the compact design of the XTS, machine builders can create much more space-efficient systems. In addition, our TwinCAT automation software delivers easy engineering capabilities, because all "movers" in an XTS system are mapped as "normal" servo-axes, and software functions like automatic buffering, and collision and jerk avoidance have already been integrated. With flexibility regarding lengths and curves, the design features all the benefits of direct drive technology such as high accuracy and dynamics, low vibration tendency, freedom from wear, and low energy consumption.

The systems are becoming more flexible and complex, but should still be easy to operate. What roles do the new multi-touch Control Panels and Panel PCs from Beckhoff play in this context?

Roland van Mark: The packaging industry in particular places great value on Control Panels with an attractive design and a high degree of functionality. That's why our new multi-touch panels are a great success. Another great sales point in this context is our long experience with customer-specific HMIs, i.e. customer-specific touch-screen solutions – from the design of the panel front to standard keyboard extensions to a completely new generation of housings. That's why nearly all machine developments now also include new and innovative operating concepts with multi-touch features. Examples include the ability to zoom into the process and rotate components more effectively as well as the freedom to use several fingers, for example, to change several parameters at the same time. Features like these are considered clear advantages for the end customer.



Uwe Průbmeier, Product Manager Fieldbus Systems and Drive Technology, Beckhoff:

"XTS now also offers a 'fast mode' for dynamically moving a fixed group of multiple movers."

EtherCAT communication features exceptional performance and flexibility. What benefits does it deliver to makers of packaging equipment?

Michael Jost: The packaging industry is characterized to a large extent by its dependence on cycle times. What matters most is how many products you can package per minute or second, which is why an extremely fast communication system with outstanding synchronization capabilities represents true innovation. This is precisely what EtherCAT offers, especially in connection with XFC (eXtreme Fast Control) technologies like "distributed clocks" for synchronized system time, "time stamping" for user data, and "oversampling" for checking process data multiple times within the communication cycle. The flexibility of the EtherCAT system provides additional benefits. On the one hand, you can select the best possible topology – star or ring – for each machine type. On the other hand, you can integrate special functionalities like safety, measurement technology or condition monitoring directly into the control system via the modular



Roland van Mark, Product and Marketing Management Industrial PC, Beckhoff:

“Nearly all new packaging systems also include innovative multi-touch operating concepts.”

EtherCAT I/O system. One example that’s particularly interesting for packaging applications is the integrated weighing technology you can implement with our analog EL3356-0010 input terminal.

Packing technology relies on highly dynamic motion control. What features does Beckhoff drive technology offer in this context?

Michael Pfister: For the packaging industry, Beckhoff offers a complete portfolio of drive solutions ranging from 50 W to 120 kW, i.e. servo drives, motors, and matching planetary gear units. The AX5000 servo drives are available in single-axis models and as space-saving dual-axis models in a single housing. The innovative AX bridge solution simplifies the DC link system, which eliminates the need for expensive braking resistance. The drives, which feature EtherCAT by default, can also be fully integrated into safety concepts via the AX58xx TwinSAFE cards. In the secondary-packaging field, you typically require more low-power applications. Here we also offer an optimized portfolio with our EL72xx servo drive terminals with ratings of up to 250 W as a complement to our AX5000 servo drives. Our motors in sizes 1 through 7 are also ideal for packaging applications because of their low rotor inertia, compact dimensions and smooth

housing design. Implementing multi-axis packaging applications is no problem. In addition, all motors can be equipped with absolute encoders, which simplify synchronization. With our AM8800 series and the matching AG2800 planetary gear units, we also offer drive technology in “hygienic design” that complies with EHEDG Class 1. The AISI316L (V4A) motors with protection class IP 69K are well-suited for extra-demanding applications, for example, in the food industry. Another truly innovative feature in terms of machine design and cost reduction is the One Cable Technology (OCT) available in our motor and drive products.

What characterizes a PC Control solution for the packaging industry from a practical viewpoint?

Frank Würthner: With PC Control we offer all the components you need for a practice-oriented packaging solution. On the hardware side, this ranges from Control Panels, control cabinets, Panel PCs and our extremely broad I/O spectrum, also in high protection categories, to our especially dynamic servo drive technology. We also accommodate special requirements, such as stainless-steel housings, FDA conformity and EHEDG certification. On the software side, we offer many packaging-relevant libraries within TwinCAT, such as dancer control,



Michael Jost, Product Manager Fieldbus Systems and EtherCAT, Beckhoff:

“For packaging technology, which is characterized by its dependence on short cycle times, the extremely fast EtherCAT communication system with its outstanding synchronization capabilities is a significant driver of innovation.”

camming, print mark control or cross-cutters. The PackML OMAC standard is also fully supported. What machine builders especially like about PC Control includes outstanding software and hardware scalability, openness for integrating their own expertise (for example, a specific closed-loop temperature controller), and its extremely powerful EtherCAT communication capabilities, especially when XFC technology is involved.

Michael Jost: Since synchronizing the various workflows is particularly important in packaging processes, packaging machine builders benefit from the speed of our data transmission, especially with the XFC technologies. EtherCAT enables easy and precise sensing of the positions within the packaging process with a standard I/O module. With the EL2521 pulse train output terminal, for example, you can simulate encoder signals that used to be external. Another concrete advantage for the machine designer: The EtherCAT I/O system is extremely compact and saves a great deal of space in control cabinets. Examples include the HD EtherCAT Terminals with their enhanced signal density and the EtherCAT Box Modules in protection categories IP 65, IP 66 and IP 67 for installation outside of control cabinets. Then there are also the EQ series IP 69K modules in 4-, 8- and 16-channels versions, which are ideal for hygienic design

applications in V2A housings with widths of only 39 mm or 72 mm.

Roland van Mark: As far as the practical benefits of our multi-touch devices are concerned, the focus is clearly on the highly ergonomic and safe machine operations they make possible. In addition, the Control Panels and Panel PCs feature an elegant, low-depth design and an optimized price-to-performance ratio with cost savings of up to 28 percent compared with previous units. This means that even price-sensitive packaging applications can offer added value with innovative operator interfaces. We offer these panels in a broad range of models for a uniform look and feel on the machine, or even as customized versions at the cost of a standard single-touch device. Additional cost and design benefits can be leveraged with the new CP-Link 4 connection technology. With this single-cable solution, which lets you install Beckhoff multi-touch Control Panels up to 100 meters (330 feet) from the Industrial PC, the video signal, USB 2.0 signal and power are transmitted via a standard CAT.6A cable, which reduces the cabling and installation costs significantly. Another benefit is the ability to install purely passive displays.



Michael Pfister: The AX5000 EtherCAT servo drives are ideal for high-speed machines, because with their current control of up to 62.5 μ s, you can implement the fastest possible positioning tasks. They are supported by the AM8000 motors, which make even extreme acceleration possible with low rotor inertia in combination with their up to five-fold overload capability. Our One Cable Technology (OCT) delivers additional benefits in real-life applications. The average packaging machine today has eight moving axes. If you can cut the number of cables down by half, you also cut costs while opening up new avenues in machine design. Even with lengths as short as 5 meters, OCT is less expensive than the traditional feedback system while delivering 10 times the resolution, a fully integrated electronic name plate, and motor diagnostics.

Uwe Prübmeier: Especially considering the XTS, the main advantages come from replacing mechanics with software functionalities. This enables the machine builder to implement motion profiles much more flexibly while eliminating expensive mechanical components. It also reduces the development time. If necessary, subsequent functionality enhancements can even be delivered to the end customer via remote access. This reduces costs significantly, because you can use the XTS as a standard element for wide ranging and diverse tasks. The modules are easily integrated into the machine, and any application



Michael Pfister, Product Manager
Drive Technology, Beckhoff:

"In terms of cost reductions and design options, our One Cable Technology represents a real milestone for the packaging machine industry."



modifications involve only additions to the mover. Packaging applications that have already been implemented include filling bags, sorting product streams, synchronizing asynchronous product streams with a cyclical product stream, intelligent and dynamic product carriers, and the inline assembly of packages.

What benefits do these features deliver for the end user's packaging process?

Uwe Prüßmeier: XTS makes it easy to implement lot sizes of 1 or special runs such as „5-plus-1“ packaging, because the mechanical modifications for a product are largely made by adjusting parameters in TwinCAT. This results in much faster product changeovers. You can simply save the parameters for a product and call them up for another run without having to make any mechanical modifications. It also requires less maintenance and cleaning, which means that you don't need highly skilled workers for these tasks. Additional savings are provided by predictive maintenance capabilities, because a direct drive “knows” all current operating values, such as the power input of each mover. This enables it to recognize overloads and vibrations at a very early stage.



Universal multi-touch panel series: Among the new items that Beckhoff is presenting at Interpack are the CP3915 and CP3918 Multi-touch Panels, which are optimized for packaging machines.

Interpack News 2014

What will be the focus of the Beckhoff presence at Interpack 2014?

Frank Würthner: At Interpack 2014 we will show all the advantages of PC Control as a flexible and scalable control solution for packaging lines. As a special focus, several XTS solutions will demonstrate the innovation potential of PC Control for the packaging machine industry. Other major topics include increased engineering efficiency with TwinCAT 3 and the role packaging machines play in Industry 4.0 scenarios.

Uwe Prüßmeier: With regard to XTS, our visitors expect to see many enhancements and adaptations in detail, most of which were developed in close collaboration with machine builders and end customers. One such example is the so-called "fast mode" as an advanced development of the energy-optimized "queue" function, which lets you form a group of several movers at equal distances and with very high speed.

Roland van Mark: We will also present our very flexible multi-touch panel range with the CP2xxx and CP3xxx Control Panel and Panel PC series at this year's Interpack. The many housing models, either "built-in" style for cabinets or other versions for installation on mounting-arms feature screen sizes ranging from 7 to 24 inches in 16:9, 5:4 and 4:3 aspect ratios as well as in landscape or portrait modes. These are supplemented by a broad range of processors up to 4th generation Intel® Core™ i processors. We will also demonstrate the capabilities of CP-Link for remote installation of multi-touch panels as well as the fanless CX5100 Embedded PC series with the latest Intel® Atom™ CPUs, introducing multi-core technology in what we consider "medium-range" controllers. Another highlight is the CP39xx multi-touch Control Panel with an IP 65 housing and a display that is laminated for extra shatter protection.

Michael Jost: Our innovations include the EL2522 pulse train output terminal in a 2-channel version, which – unlike the 1-channel terminal – features a third differential output as a reference pulse signal. Another highlight is the EL9576 brake chopper terminal, which can be used in connection with stepper motor terminals, DC motor terminals and servo motor terminals to store back currents or discharge feed-back energy via a ballast resistor. The servo motor terminals, which are available with a resolver or in OCT versions, also include an advancement: the double-width (24 mm) EL7211 with its effective current output of up to 4.5 A significantly expands the areas in which terminal-based servo drive technology can be used.

Michael Pfister: The new AM811x and AM801x servo motors with their scalable output ranging from 50 W to 250 W feature single-turn or multi-turn encoders with 15-bit resolution and One Cable Technology. With a flange of 40 mm, they are designed for extremely small spaces. Industry-standard rotating quick-connectors simplify cabling efforts. The available lengths and an optional zero-play permanent-magnet brake cover a broad spectrum of applications. Especially the combination of AM811x motors with the new EL7211-0010 servo motor terminal for an output of up to 4.5 A_{RMS} at 50 V DC represents an exceptionally compact and affordable servo system.



With the introduction of the CX5100 Embedded PC series, Beckhoff makes multi-core technology now also available for controllers in the medium performance class.

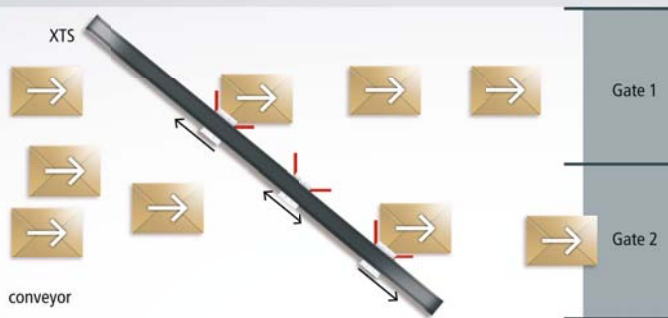

Figure 2: Functioning as a distribution system, the XTS splits an incoming product stream into multiple streams (two in this case) inexpensively and with great flexibility.

as lower costs and significantly simplified product changeovers and process adjustments. In addition, the customer benefits from short response times, for example, when a feeder component fails. The software responds by redirecting the product stream automatically or at the push of a button. The high functionality and cost efficiency of the XTS also makes it possible to implement workflows that were too expensive and/or complex in the past.

All these benefits don't just reduce costs and increase the machine's availability, but raise the overall level of equipment performance. Here, the XTS provides another opportunity for maximizing performance: Since a machine's slowest processing unit determines its overall speed, potential improvements in the faster units tended to go unrealized in the past. With the XTS, the slowest station can operate faster or be used multiple times, thus eliminating previous bottlenecks. The following six practical applications illustrate how these benefits can be leveraged on the shop floor.

Product stream separator

Figure 2 shows the XTS being used as a sorter that separates a stream of small boxes. The vertical XTS is positioned diagonally over the conveyor belt. Based on the information gleaned from an object recognition system, a mover travels to an arriving box and uses an attached angled gripper to push it up or down on the belt. When the box is properly positioned to enter one of the gates, the gripper releases it, and the box travels down the belt in a straight line.

This simple yet extremely effective XTS application features much more flexibility than traditional mechanical solutions, because the boxes can be distributed freely, whether you want to alternate them between the two gates or fill a certain recipe or sequence. Driven by software, the boxes can be easily distributed over the two gates (for example, in a 2:1, 3:2 or 4:1 ratio). You can also set desi-

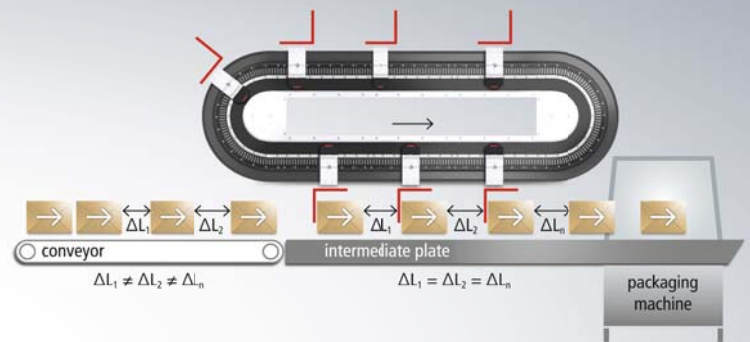

Figure 3: The XTS makes it easy to implement a feeder with distance adjustment that synchronizes products arriving at different intervals with the downstream process.

red distances between the boxes. There is no need to change any mechanical components or tools, which raises the machine's overall availability significantly. The solution is also very fast. In an existing application, the conveyor moves at speeds of up to 3.5 meters per second, which poses no problem for the XTS. In addition, the control electronics are able to respond easily to speed changes – for example, when the machine starts up. That way, the XTS is always perfectly synchronized with the conveyor.

Feeder with distance adjustment

The XTS arrangement shown in Figure 3 is the ideal solution for synchronizing a totally irregular stream of products with a downstream process – in this case, a machine that packages small boxes. Many systems such as blister pack machines or assembly installations cannot be arbitrarily stopped and started, which is why they need precisely defined and regular distances between products. To make this application work, however, the average stream of incoming products must match the processing capacity of the downstream system. The XTS mover with its attached pusher or gripper shoves one of the irregularly arriving boxes from the conveyor belt to an intermediate buffer area and moves or accelerates in such a way that it re-enters it at the preset distance to the preceding box.

What sounds fairly easy with XTS was very difficult in the past and could not always be accomplished in an economically feasible manner. In conventional systems, the boxes are initially accumulated against a barrier, with the conveyor belt continuing to move (and slip) under the stopped boxes. At the right moment, the barrier is removed long enough for a single box to pass through. A typical example of this approach is a bottle conveyor in a brewery, because bottles can tolerate rough handling. With more sensitive products, such as cardboard boxes with heavier contents, this procedure would cause unacceptable damages, however. It also would cause major problems with sticky items such



Figure 4: As a carousel-type solution, the XTS is ideal for bottling applications that must process a continuous product stream in a discontinuous fashion.

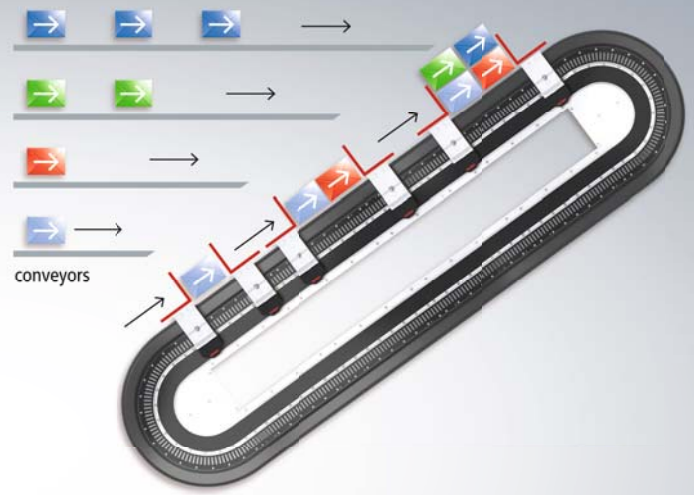

Figure 5: Used as a grouping system, the XTS can easily combine products arriving on multiple conveyor belts into predefined and easily changed groups and move them to the next station.

as cold-cut slices or chocolate bars, because the friction from the conveyor belt would be too strong and cause the products to stick together. For products this sensitive, two conveyor belts are usually employed, with the second belt running faster and the distance between products being regulated via a mechanical adjustment of the belt lengths. This requires a buffer belt between the conveyor belts that is very complex and hard to clean, particularly for food industry applications. Needless to say, an XTS solution is much less cumbersome and less expensive.

Carousel for asynchronous transport with synchronous feed-in

A bottling machine is a prime example of an XTS application using a carousel with asynchronous product transport and synchronous product feed-in (Figure 4). Thanks to the separately controllable movers, the machine can grab the continuously arriving bottles, accelerate them individually, and move them as quickly as possible (even with a head start) to the more time-consuming filling station. The flexibility of the XTS also makes it easy to install several instances of the slower subprocesses such as the filling stations and supply them continuously with bottles. That way, the bottling line can be operated very efficiently and with maximized capacity by installing expensive, but fast subprocesses, such as weighing and labeling, only once, while having several instances of slow units, such as the filling process.

Without the XTS, this would be very complex and expensive. In the simplest case with a traditional system, the entire product stream would have to be stopped and started continuously – with the result that the entire line can only be as fast as its slowest unit. Accordingly, the other stations would have to wait, which would reduce their efficiency considerably.

Individual and varying product grouping

The benefits and simplicity of the XTS are especially apparent in the setup for individual product groupings shown in Figure 5. In this example, different-color boxes (or bags with different kind of chips or candies, for example) arrive at the XTS on four separate conveyor belts. Using two movers to grab each item, the system arranges them in predefined groups and transports them to the next process step, for example, the boxing station. Even the distance between the groups can be controlled.

The benefits of software-based control over mechanical control are particularly apparent in this application. On the one hand, defining new product groups is very easy. For example, all it takes to change the quantity of certain items is to instruct the pairs of movers to grab them in a different order. Changing the total number of items in a group is just as easy. This capability also makes it easy to accommodate temporary offers such as “3+1” specials. On the other hand, if you have multiple conveyors, there is always a risk that one of them fails. With the XTS, this is no problem – at least not if all conveyors deliver the same product. All you need to do is program the software to skip the failed conveyor and pick up more items from a functioning conveyor.

Gantry system for individual track profiles

The advantage of having individually controllable and coordinated movers is also apparent in applications where the XTS is used as a gantry system for individual track profiles (Figure 6), because two movers can be synchronized not only within the same system, but between two different XTS systems, which in this case are installed side-by-side. In connection with matching kinematics

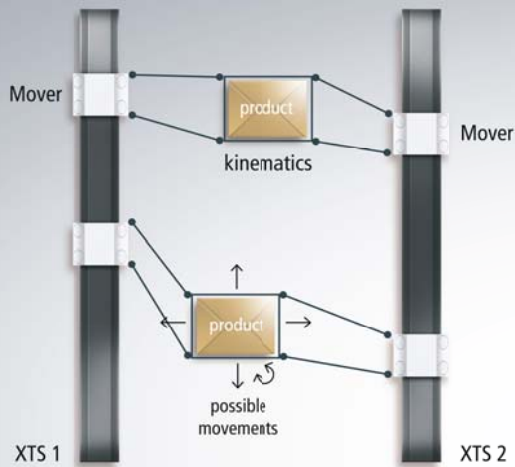

Figure 6: By using two synchronized XTS movers arranged in parallel and employing simple kinematic components, the products can be routed along freely programmable travel profiles.



Figure 7: The combination of a horizontal XTS and vertical systems – here a demo application from the 2014 Hannover Messe – is a great way to separate specific elements from the product stream and rearrange the stream in accordance with the desired criteria.

components (for example, hinged levers), such a setup makes it possible to transport products in ways other than just in a straight line. This ability comes in handy when you need to travel along a product's edge or execute a rotating motion, such as screwing on a lid.

In another concrete application, a box could be grabbed via levers and moved underneath a glue jet, for example. Once it arrives there, the movers use the attached levers to guide the product with great precision underneath the glue jet. What makes this solution so special and less expensive is the fact that the usually heavy glue jet is not required to move over the product with the help of an expensive robot; instead, the jet is stationary while the product itself travels through the transport unit.

Sorting in accordance with defined and flexible patterns

Figure 7 shows a demo installation from the 2014 Hannover Messe that sorts balls based on their color. It consists of a combination of one rotary-table-type machine from which the balls are picked up and two vertical XTS systems that hold, buffer and dispense the balls as needed.

This is an efficient method for removing bad parts from a product stream or – as in the demo installation – for sorting incoming products based on certain characteristics. Here, too, the advantage of replacing traditionally mechanical functions with software is readily apparent, because the process can instantly adapt to changing selection criteria.

Further Information:

www.beckhoff.com/xts

Two movers hold the bag firmly and open it by driving a little towards one another while the outside edges of the bag are held by a vacuum.

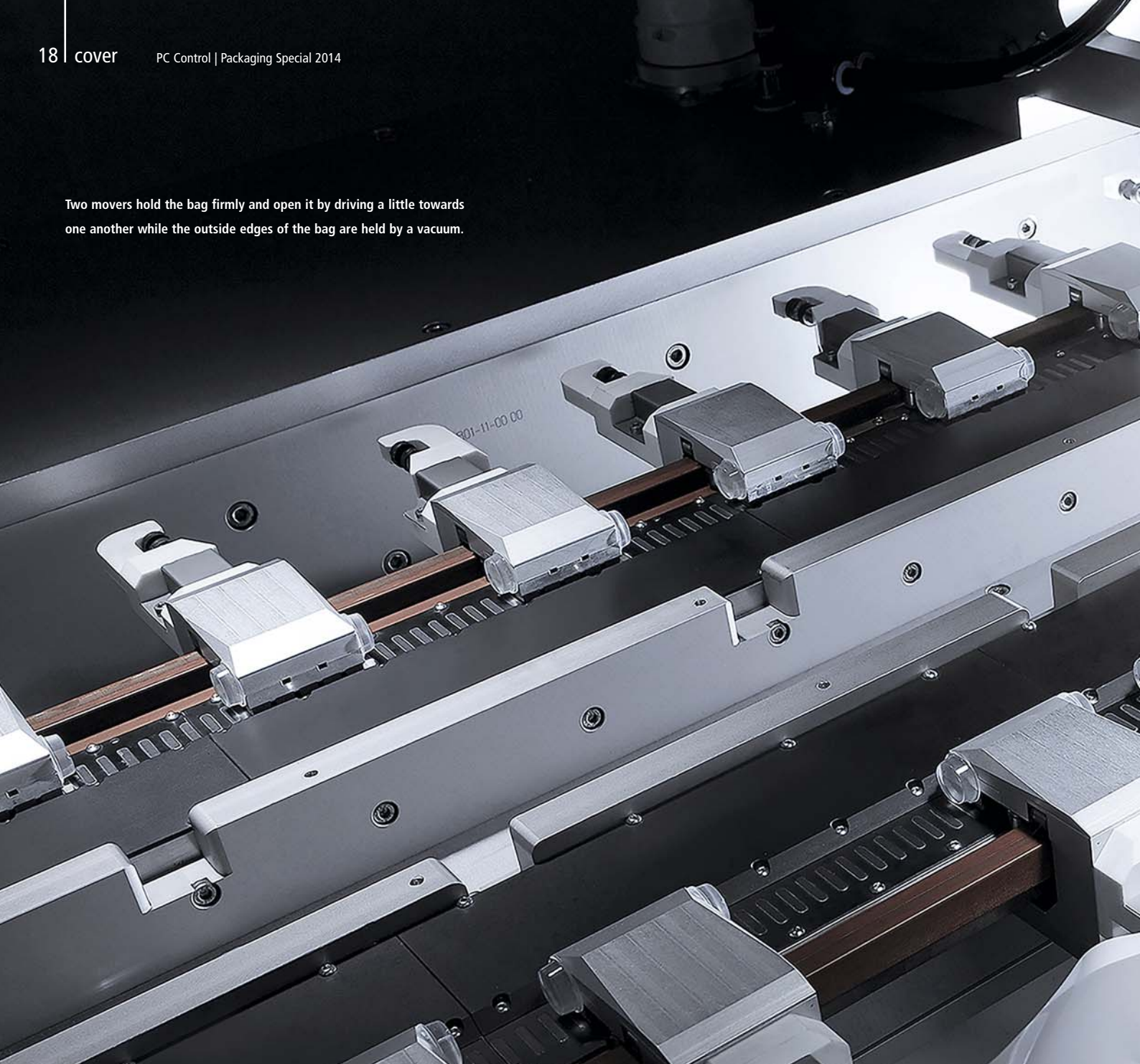

Technical Development Corporation develops one of the first applications on the basis of the eXtended Transport System (XTS)

XTS revolutionizes machine design in the packaging industry

Specializing in machines for the processing and packaging of tobacco, the Dutch company TDC (Technical Development Corporation), has realized a pilot project that leverages the flexibility of the eXtended Transport System (XTS), which is a linear drive solution from Beckhoff: 'Doysis' is a machine for forming, filling and sealing stand-up pouches for tobacco packaging.



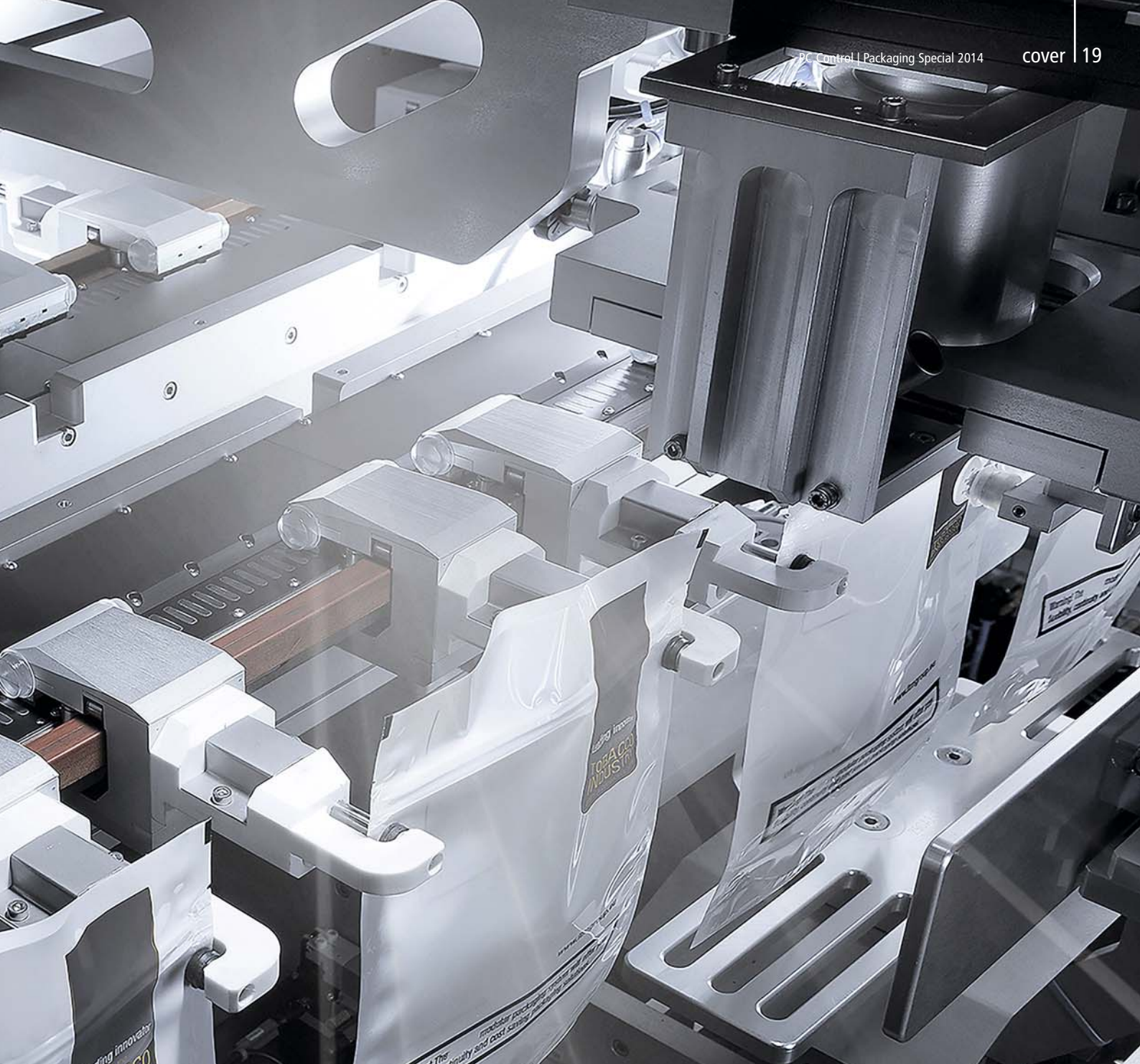

The Doysis packaging line project kicked off in December 2012. That was when TDC received an order from a Polish tobacco manufacturer for the development of a plant to fill tobacco into stand-up pouches – so-called doypacks. The packaging of tobacco is a demanding process, since the natural raw material can vary with regard to dimensions, form, density and bulk weight.

The drive and control system of the Doysis are completely based on standard Beckhoff components: a C6930-0040 Industrial PC with powerful dual-core processor, a Control Panel, EtherCAT I/O terminals, TwinCAT 3 and the XTS linear transport system. The entire machine uses EtherCAT for communication.

Complex production process

At the start of the process, tobacco is weighed outside the filling machine and transported in containers to a pressure chamber, where it is pressed so that the amount to be placed into the bag always has the same size and form. The Doysis production process starts with the manufacturing of the stand-up pouch from plastic film, which is formed into a U-shape, and a zip fastener is attached for reclosing the bag. Subsequently, the sides are sealed together. In the next step the bag goes through a labeler or a text printer, is provided with a notch and cut to size. Afterwards, two XTS movers take each bag and open it by driving a little towards one another while the outside edges of the bag are held by a vacuum. Via a buffer station four bags are placed at the same time under one pressure chamber. These modules de-



The Technical Development Corporation is one of the first companies worldwide to use the eXtended Transport System XTS.

veloped by TDC place the quantity of tobacco, which has been compressed into a small package, into the bags. After filling and buffering again, the bags are shaken, blown clean with ionized air and sealed. Afterwards a hole is punched in the bag for hanging on retail fixtures and an adhesive layer is applied for the revenue (tax) stamp. The presence of the revenue stamp and its correct position are checked by a vision system. Incorrect product packages are unloaded from the machine; correctly manufactured bags are placed on a conveyor belt and transported further.

XTS: optimum flexibility and minimum installation space

In previous machine generations from TDC the filling process was mechanically driven. The major disadvantage of this was that the process took place according to a set pattern and with a fixed cycle time. The development of the new filling line was based on the concept that it should be as flexible and modular as possible. In the search for a suitable transport system with which the packaging concept for stand-up pouches could be realized, TDC came across the eXtended Transport System XTS. The concept of the XTS, a linear motor that drives in a circle with separately controllable, flexible movers, perfectly suited the idea that TDC had in mind for its new machine: in this way, for example, it is possible to attach several pressure chambers or process modules along the line so that its capacity can be increased.

One of the big advantages of the XTS is that the rigid clocking of the production process can be dispensed with. In order to achieve a high production output with a mechanical solution, many stations would have to be implemented twice or more. By using XTS, the number of stations can be reduced considerably. This leads not only to a cost savings with regard to the required hardware, but it also means that there are fewer mechanical components to be maintained.

When changing the product or bag format, the machine also no longer needs to be mechanically retooled; instead, the settings for the movers and

the process sequence will simply be changed in the software, which requires much less effort. Thanks to the individual programming of the movers, the bags can be positioned, filled and handled individually. In principle, the manufacturing of various compositions and filling weights of the tobacco in different sequences, i.e. a lot size of one, is possible with XTS. In the future it will also be possible to move the filling stations together with the movers according to the 'flying saw' principle, resulting in a continuous flow of product.

Over and above that, the compact XTS drive system creates dramatic space savings: a conventional machine that does what the Doysis does would be considerably larger, since virtually all stations would have to be implemented several times. With the reduced footprint of the machine, enabled by the XTS, the end user gains a clear cost benefit.

Efficient engineering with TwinCAT

In terms of software, the Doysis is a sophisticated project: the application software was created using object oriented programming in the engineering environment of TwinCAT 3.1. The XTS is structured on the software side as an object, i.e. each mover is regarded as a servomotor. TwinCAT contains all drivers and routines for every mechanical, magnetic and electrical implementation. The software was developed by the Dutch software specialists Gain Automation Technology who had already carried out several TwinCAT pilot projects and had experience with IEC 61131-3 programming. An important advantage of TwinCAT 3 is that all the processor cores of a CPU can be fully utilized, which is of great importance for the performance of the machine.

All challenges overcome in record time

TDC is pleased with the results in every respect: thanks to close cooperation between TDC, Gain and Beckhoff, it was possible to implement the entire machine, from the concept to delivery – i.e. development,



The Doysis filling line is very complex, but was completed in just eight months. Thanks to its modular and flexible design it is also suitable for other industries in addition to the tobacco industry.

engineering, construction of the machine and the writing of the software – in just eight months.

The Doysis was put into operation by the customer in September 2013 with 32 movers. The machine fills 50 bags per minute. It is planned to increase that to 60 bags per minute, which has already been accomplished with the second filling line, which is standing at the ready in the TDC Innovation Center in Kampen for further development. TDC assumes the machine, thanks to its flexible and modular structure, can be marketed in other industries and packaging applications, too.

Technical Development Corporation (TDC)

The Technical Development Corporation (TDC) was originally based in Switzerland, but was taken over in 1995 by the Dutch company SCM (Sluis Cigar Machinery). The main line of business of this company at that time was the production of tobacco weighing equipment and filling lines. When TDC's head office was relocated to Kampen in the Netherlands, all activities in the 'hand-rolled tobacco' field were concentrated in this group company. TDC's product range extends from the individual machine module up to a complete production line for the tobacco industry.

Further Information:

www.itmgroup.eu

www.gain.nl

www.beckhoff.nl



The multi-robot H 240 handling module automates handling in packaging processes effectively, efficiently and extremely dynamically with up to 240 pick-and-place cycles. It is also extremely hygienic through the use of AM8800 stainless steel servomotors.

TwinCAT robot kinematics and servo drive technology promote efficiency in food packaging

MULTIVAC: Optimal hygiene safety ensured right down to the stainless steel motors

MULTIVAC successfully fulfills extremely strict hygiene requirements with its expertly-designed packaging systems for the food industry. This also applies to the company's handling modules with proprietary pick-and-place robots. In terms of control technology, the solutions are based on TwinCAT automation software with its robot kinematics as well as the ultra-fast EtherCAT communication system. Not only do AM8800 servomotors ensure highly dynamic movements, their "Hygienic Design" helps enable handling robots with a completely open construction that makes them effortlessly easy to clean.

MULTIVAC Sepp Haggenmüller GmbH & Co. KG, with its headquarters in Wolfertschwenden, Germany, is a full-range supplier of packaging solutions for the food, medical and consumer goods industries. In addition to packaging machines, the MULTIVAC portfolio includes handling modules for loading, unloading and channeling, inspection systems for quality control and detection of foreign bodies as well as marking and labeling solutions for different package types. The food sector represents the most important user industry for MULTIVAC solutions, where efficient, accurate, and above all, hygienic packaging of goods such as meat, fish, cheese, vegetables and ready-to-eat meals is imperative.

PC-based control technology for efficient packaging processes

MULTIVAC relies on PC-based control technology from Beckhoff to automate all of its standard packaging machines. Back in 2005 the company replaced microprocessor-based controllers in order to meet the growing demands of increasingly complex machines with ever greater functionality through more computing power and memory. Added to that, PC Control permitted communication connections, for example via Ethernet and OPC, to be simplified considerably through standard interfaces and standard software libraries, reducing the development overhead to a minimum as a result.

According to Alois Allgaier, who heads up the MULTIVAC Control Technology Division, another advantage of PC-based control technology lies in the excellent scalability: "On one hand we can always use exactly the right Embedded PC for machines whether small or large, but with the same functionality offered on the software side every time. On the other hand, the I/O equipment can be adapted exactly and cost-efficiently to the requirements of the application thanks to the modular and versatile EtherCAT I/O system." Optimal adaptability for Alois Allgaier means that the packaging machines can be modularized very efficiently by means of the flexible EtherCAT terminal system: "Our machines are controlled centrally from a CX1020 or CX1030 Embedded PC, but are split between three decentralized control cabinets at the I/O level. This means, for example, that all data acquisition and communication for one forming station can be realized in the associated control cabinet module. The required communication with the central controller is handled by the extremely fast EtherCAT system, which was also an important aspect when deciding in favor of PC Control. Ultimately, the clock speeds that can be achieved by the packaging machines depend directly on ensuring shortest possible cycle times of the control technology."

Flexible handling modules with numerous available robot types

The MULTIVAC handling modules automate a broad range of packaging tasks. This includes the loading of products, separation and orientation of packs, rejection of defective packs and box loading of packs. Depending on requirements, the systems can be equipped with robots that have two, three or four axes and can be used flexibly, for example, with a wide range of products, pack formats, weights and cycle times.

The handling systems can generate practically any pack pattern to ensure that the capacity of secondary packs is optimally used. Interlayers and dividers can also be inserted automatically. Thanks to this versatility as well as the hygienic and FDA-compliant stainless steel machine construction, which allows wet cleaning of the entire handling unit, the MULTIVAC modules are ideal for all products and production environments in the food industry.



The AM8800 stainless steel motors can be used in open designs, i.e. without protective housings, facilitating optimal cleaning of pick-and-place robots.

Hygiene benefits from open frame construction and stainless steel motors

There were a number of reasons why MULTIVAC developed their own handling modules and robots explains Alois Allgaier: "We have implemented extremely strict hygiene requirements with our packaging machines for the food industry, which were also our benchmark in the area of handling and robotics. Because there were no suitable systems available on the market, we developed our own robot arm for the infeed area based on our own ideas and objectives. The result is a stainless steel frame construction that can be optimally cleaned because it is completely open. The FDA-compliant AM8800 stainless steel servomotors from Beckhoff also played their part as they can be installed simply without an additional protective housing."

The servomotors in the AM8800 series have a stainless steel housing that is designed according to the EHEDG (European Hygienic Engineering Design Group) guidelines in "Hygienic Design". The lubricants used are certified food-safe (FDA). The motor windings are implemented using salient pole-wound technology. This results in a high copper space factor and correspondingly high

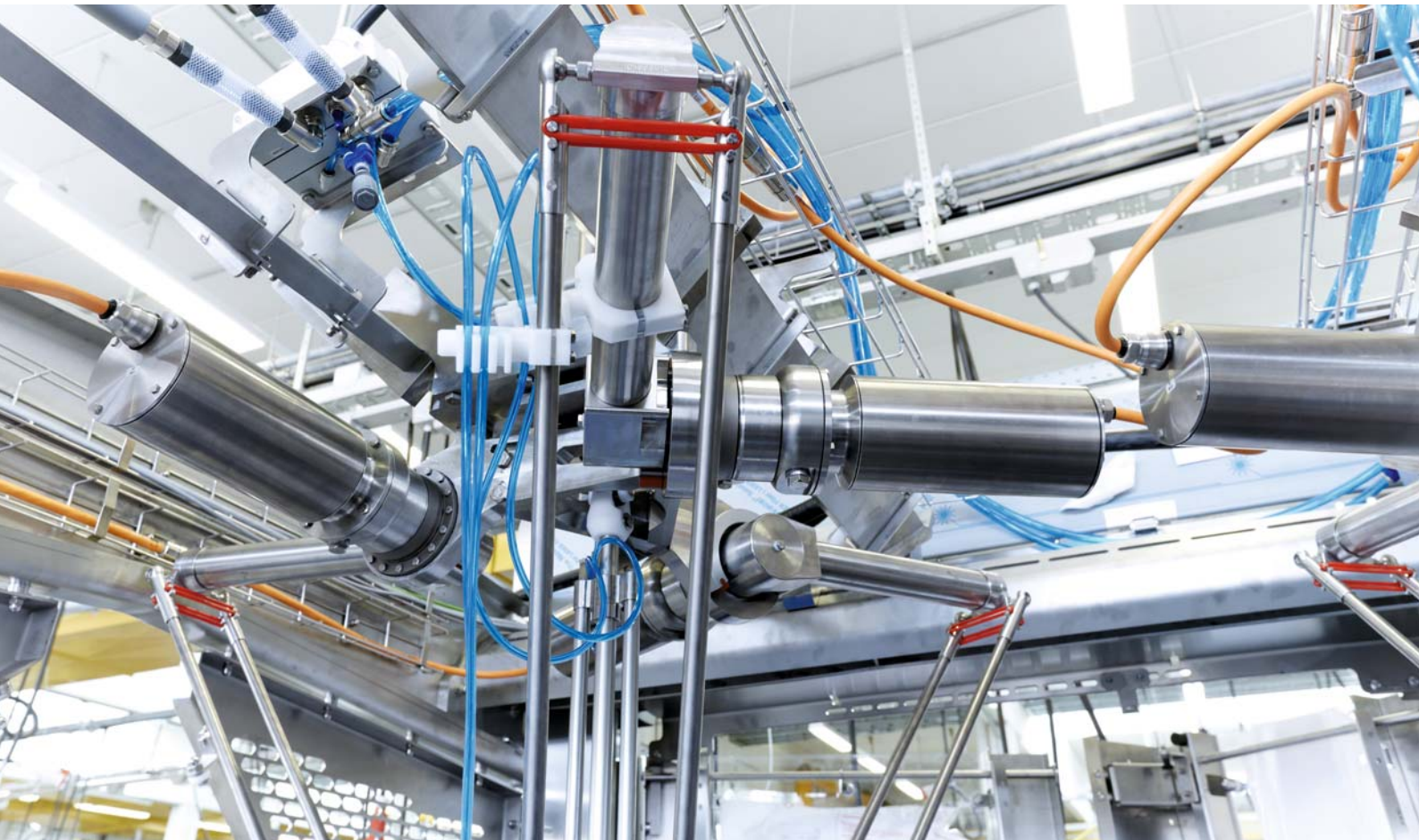

One Cable Technology (OCT) offered in the AM8800 motors not only reduces the cabling overhead, it also minimizes the risk of dirt deposits by eliminating 50 % of the motor cables and connectors.

continuous torque. The fully potted stator provides a thermally ideal transition of the winding to the housing. A further advantage of this is the mechanical protection of the winding wires against vibrations. Since the housing and motor shaft are manufactured from scratch-proof stainless steel (AISI 316L), no corrosion creep or damage to the finish is possible. The motors are manufactured with standard IP 69K protection, allowing the use of steam and high pressure cleaners. An optional sealing air connection is also available to prevent the formation of condensation.

MULTIVAC uses the 2-channel AX5206 EtherCAT servo drive from Beckhoff for motor control with the pick-and-place systems, which enables operation of two of the same or even differently sized motors. The stainless steel servomotors used include the AM8843 types with 3.9 Nm rated torque, 4.5 Nm standstill torque and 16.5 Nm peak torque as well as the AM8852 with 5.1 Nm rated torque, 6.0 Nm standstill torque and 22.5 Nm peak torque. This enables the implementation of highly dynamic and precise handling tasks in conjunction with the fast EtherCAT communication.

One Cable Technology improves hygiene and reduces costs

The cable gland of the servomotors is also implemented in "Hygienic Design" just like the housing. In terms of hygienic safety, One Cable Technology (OCT) from Beckhoff provides yet another advantageous point for Alois Allgaier

when connecting the AM8800 servomotors: "As one of the usual motor connection cables is not needed, there is also one less place for pockets of contaminants to form. That was another important factor for us when opting to use OCT."

In addition, the fundamental advantages of OCT such as reduced component and commissioning costs can be leveraged. Finally, because motor feedback signals are sent directly along the conductor to the power supply, a cable and plug can be omitted, which saves both material costs and cabling overhead.

Robotics, motion control and PLC on one dynamic software platform

TwinCAT automation software from Beckhoff combines PLC, motion control and robotics in one integrated platform, which was a decisive advantage of PC Control in Alois Allgaier's point of view from the very outset: "Even when developing the robot arm we were certain we did not want to use a separate robot controller. TwinCAT enables the entire control technology to be fully implemented in one software system and for commissioning to be performed extremely quickly. For example, the stainless steel motors can be incorporated with ease into the software by means of the servo amplifiers and the motion sequences of our applications can be realized very efficiently using TwinCAT NC PTP and the kinematics library."

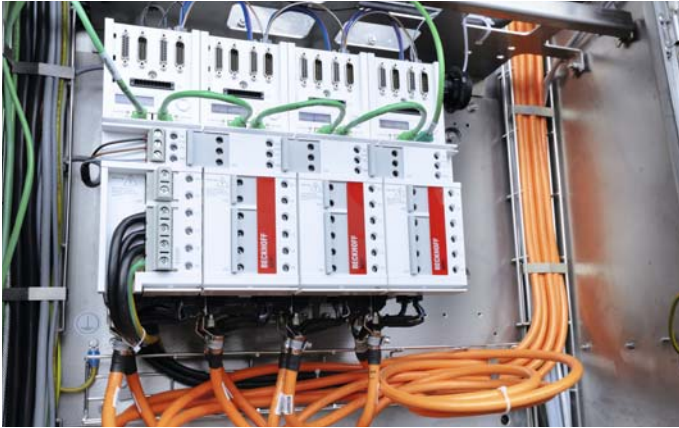

MULTIVAC uses the 2-channel AX5206 EtherCAT servo drive for precise pick-and-place tasks.



A CX1030 Embedded PC, TwinCAT NC PTP and EtherCAT communication ensure fast and precise control sequences for the handling modules.

Alois Allgaier, Head of the MULTIVAC Control Technology Division: "Thanks to our own robotic system, we can offer excellent hygiene safety standards in our packaging and handling systems."



Robot functions can be mapped easily in the automation software using "TwinCAT Kinematic Transformation". This TwinCAT supplement integrates transparently into existing motion control systems. Robotic and motion control functions can therefore be synchronized optimally in one harmonious environment. For example, the 3D delta kinematics can be coupled without great difficulty with the "flying saw" functionality in order to synchronize with conveyor belts to pick or place packs. Various types of robot kinematics can be realized, with the movements programmed in Cartesian coordinates either with DIN-66025 commands or with the PLCopen-compliant components from the PLC. An integrated dynamic pre-controller ensures very precise movements even at high accelerations and speeds. TwinCAT Kinematic Transformation contains Cartesian portals, 2-D parallel kinematics, shear kinematics, crane and roller kinematics, 3-D delta and SCARA kinematics.

Intuitive operator interface via FDA-compliant stainless steel Panel PC

The benefits offered by PC control to Alois Allgaier in terms of system flexibility are not limited to the control software: "We can offer the handling modules with two different control concepts, entirely according to demand: On the one hand this could be a modular system, in other words, with its own Embedded PC. On the other hand, the module could take the form of an element integrated at a deeper level into the packaging system, and running as software on the controller in the main packaging machine. Beckhoff automation technology offers a major advantage through this flexibility. The handling robot is operated accordingly, either by means of its own HMI or via the packaging machine terminal."

A custom-designed CP7201 Panel PC with 12-inch touchscreen in a high-quality stainless steel design is used as the display and operating terminal with an IP 65 rating. The Panel PC is characterized by its "Hygienic Design" as with the stainless steel servomotors, in other words, by gap-free housing design in a flush-fitting touch panel. The HMI 2.0 user interface from MULTIVAC allows simple, intuitive and reliable operation of the handling modules as well as the entire packaging machine. The plain text information display, rich graphics and video sequences, 200 freely assigned program presets, 36 available interface languages as well as a multi-level access rights management also contribute to intuitive and secure operation around the world.

The handling modules can either be operated via the HMI 2.0 user interface of the packaging machine or equipped with their own MULTIVAC-specific CP7201 Panel PC from Beckhoff.



Further Information:
www.multivac.com

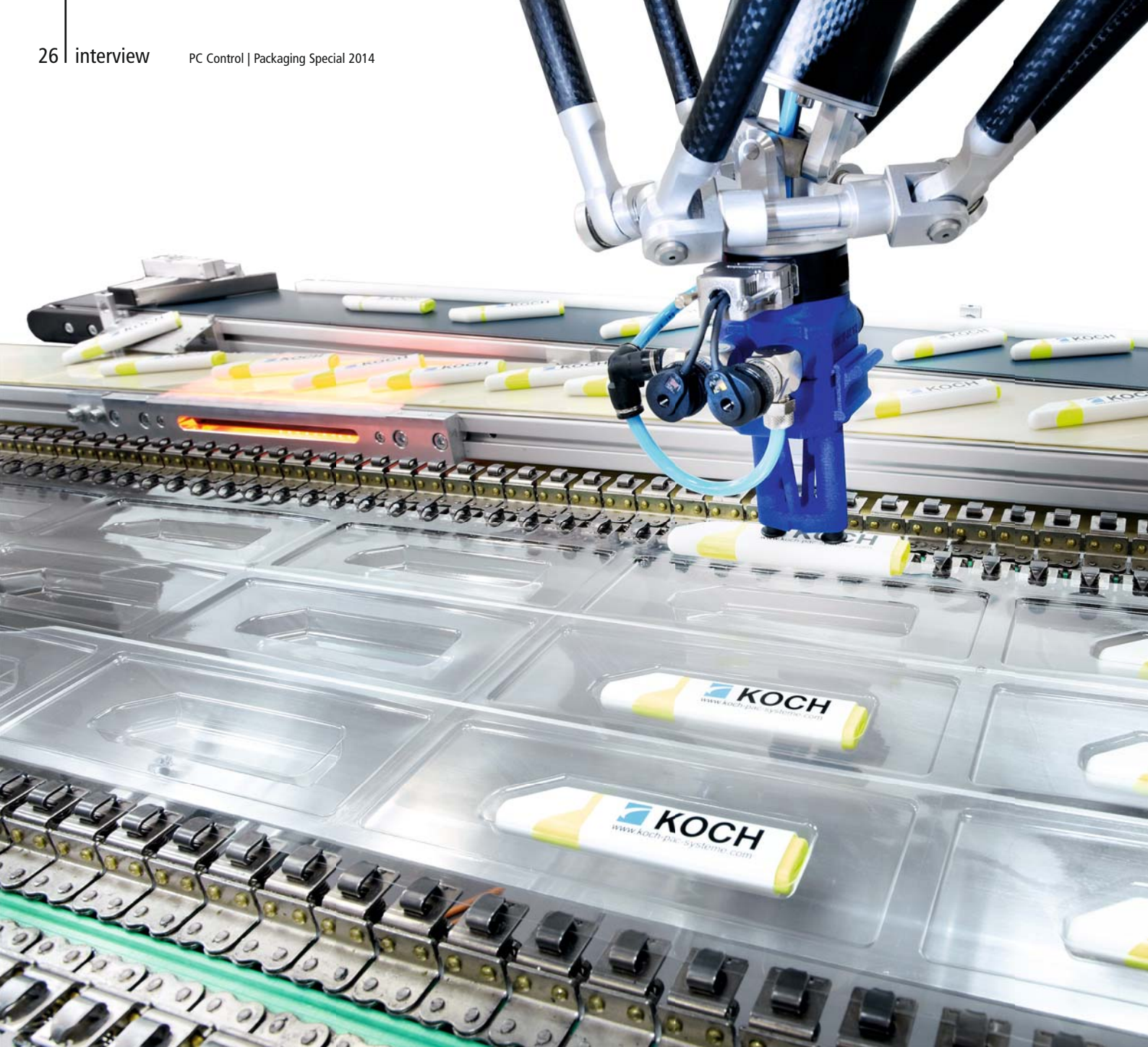

Interview with Jürgen Welker of KOCH Pac-Systeme on the design requirements of special machines for the packaging industry

Modular control technology for compact packaging lines, including in cleanrooms

KOCH Pac-Systeme, based in Pfalzgrafenweiler, Germany, specializes in customer-specific blister packaging machines and plants. A prerequisite for the flexible and efficient implementation of specific application requirements is a consistently modular machine design that is ideally supported by the finely scalable and open control and drive technology from Beckhoff. Jürgen Welker, Head of the Automation and Service Division at KOCH, explains where the specific advantages of PC control help, in particular in the demanding field of medical technology.



Jürgen Welker, Head of the Automation and Service Division at KOCH, in front of the new KDT medplus rotary table machine, which is conceived for cleanroom use in medical fields.

Which markets are most important for KOCH Pac-Systeme and what distinguishes your portfolio of solutions?

Jürgen Welker: KOCH offers packaging solutions for the most diverse industries, in particular for hard blister packs. We are clearly specialized in the design of special machines, that is to say, customer-specific machines and plants. It is precisely this flexibility and individuality that makes our products stand out as unique. We distinguish between three target markets – consumer goods, cosmetics/hygiene and medical technology, in which cleanroom requirements play a major part. In addition to that, KOCH considers not just the packaging machine itself, but also the entire process. Functionally, this ranges from the blister design and quality assurance to tracking and tracing, and on the plant side from the deep-drawing station, depalletizing robot, pick & place handling and sealing, up to the grouping of individual blisters and their final packaging.

How important is modularized machine design for custom packaging solutions and to what extent does Beckhoff control technology support you in that?

Jürgen Welker: A consistently modularized machine design is the prerequisite for packaging solutions that are tailored to precise customer specifications, but are nevertheless inexpensive. For example, our rotary table machine with sealing station can be extended by cover foil feeding, a back and front card inserter or automatic product feeding, depending on requirements. On the control side this is optimally supported by Beckhoff technology. We benefit here from efficient and flexible EtherCAT communication in conjunction with the wide range of digital and analog EtherCAT Terminals. Although the controller itself is still implemented using a central Beckhoff Industrial PC in order to minimize hardware costs as well as software and commissioning efforts, it would be equally simple to modularize with Beckhoff Embedded PCs.

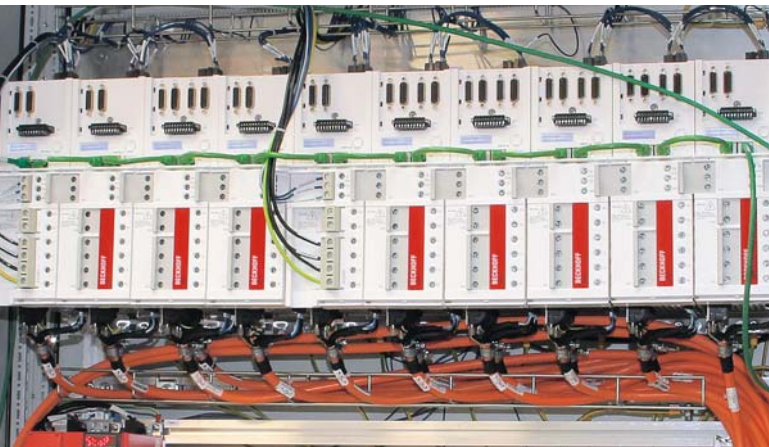

The AX5000 EtherCAT servo drives are connected to the AM8000 servomotors via the OCT (One Cable Technology) solution, which saves around 40 % of the installation time.



The I/O data points are acquired for the most part via EtherCAT Box Modules with IP 67 protection for a space-saving and flexible architecture as well as for a minimization in the number of switchboxes.

How long have you been using PC control as the control platform?

Jürgen Welker: KOCH has been using PC control since 1996, and including servo drive technology since 2011. One of the main reasons for this is that back then we had to implement our machine controllers with the most diverse PLC systems according to the customers' wishes. With the very flexible Beckhoff technology, which is fully open for the world of automation, we could finally replace the wide range of PLCs that had to be supported up to then. In addition, the openness of the PC provided simple connections to higher-level systems. Considering the flexibility of TwinCAT PC-based control software, no traditional PLC programming tools could compete in any way. We still benefit greatly from the system openness, even today. An example of this is the established communication standard EtherCAT, which enables connectivity with all required components up to printers and scanners.

Your machines are flexible and yet simple to commission. What parts do PC control and TwinCAT play in this?

Jürgen Welker: For the machine manufacturer a huge advantage of Beckhoff automation technology, and especially of TwinCAT, is the very flexible system. For the controls programmer, of course, the software is still very structured in its organization. Another benefit is the simple communication with ERP systems, for example, via the SAP interface implemented by the TwinCAT OPC Server. This is especially useful for end users. We use TwinCAT NC PTP in our plants, plus TwinCAT NC I for the delta kinematics functionality which is automated using Beckhoff drive and control technology. We benefit here once again from the system openness, because many functions such as the heating PID controllers can be implemented using preconfigured TwinCAT libraries. If necessary, however, we can also integrate our own expertise - for example, our delta kinematics.

What unique advantages does the PC control hardware offer from your point of view?

Jürgen Welker: One very important item for our compact machines is the OCT (One Cable Technology) solution, which offers not only reduced installation

effort but also the advantages of the electronic name plate and the integrated absolute encoder. The main advantage is in the commissioning, however, due to the extreme reduction in the frequency of cabling errors. Specifically, OCT saves us around 40 % of the installation time and approximately 25 % of the costs. Another big advantage with regard to the flexibility and compactness of our plants is offered by the Beckhoff I/O system with its EtherCAT Box Modules in IP 67 protection. These I/O modules now acquire well over half the data points in the plants and they do so extremely efficiently, directly on the spot in the process, without the need for bulky terminal boxes.

In the 'medplus' line, you offer packaging machines specially designed for the medical industry. How do these differ from the standard offerings?

Jürgen Welker: Our new 'medplus' brand primarily features machine design in GMP (Good Manufacturing Practice), the cleanroom-compatible machine design, the calibration of relevant process parameters and machine construction according to GEP standards (Good Engineering Practice). The latter means, among other things, ease of cleaning, avoidance of hollow spaces, special lubricants, closed cable ducts and medically-compatible materials as well as qualification and validation documents compliant with GMP, GAMP 5 and ISO. In addition, the individual projects are attended to by a team of specialists. The result of all this is not only that a product is packed without errors, but also that the product quality is perfect and that the product reliably matches the respective packaging. At the end of the day it would be fatal if, for example, the plant were to swap a medication for raising blood pressure with one to lower it, or if a replacement knee joint of the wrong size were packed.

What do the requirements of medical and cleanroom technology mean for the automation technology?

Jürgen Welker: The special requirements for the automation technology are defined in the GAMP guidelines (Good Automated Manufacturing Practice). For example, how does a program have to look or how is a program modification recorded? Accordingly, a considerably greater number of monitoring mechanisms have been implemented in the 'medplus' version than in the standard

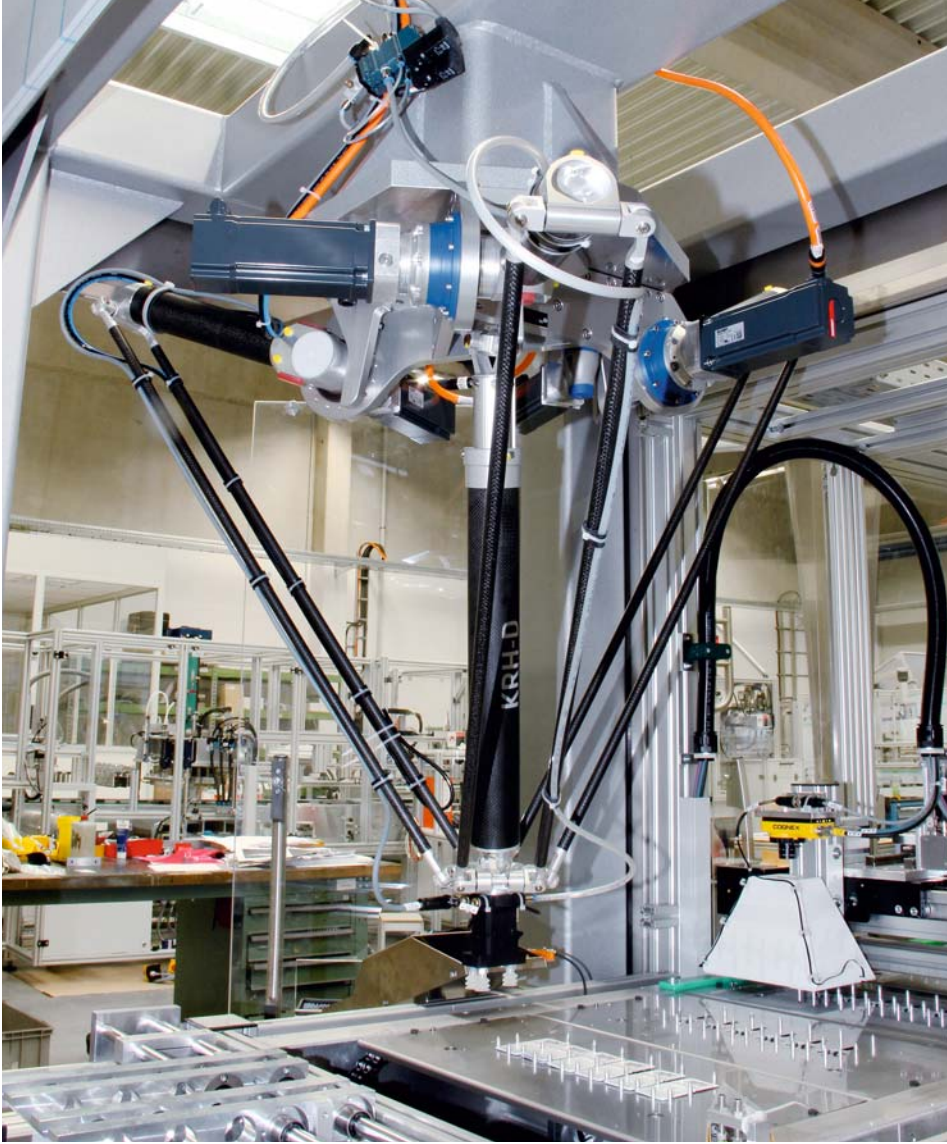

The KOCH delta robot also benefits from the high dynamics of the AM8000 servomotors.

versions. For instance, the printing on each package is inspected again afterwards to ensure that the product and the packaging information correspond. The 'medplus' know-how, thus has less to do with machine design and more to do with automation technology. Apart from these guidelines, the machine footprint is always an important issue in medical technology, because the plants are operated in expensive cleanrooms with limited space. For us as machine manufacturers this means that extremely compact systems are required, which we can achieve in large part due to the Beckhoff technology. As already mentioned, the EtherCAT Box Modules help, but so do the space-saving servo drives. We benefit in particular from the compact EL72xx servomotor terminals, which create enormous space savings.

For which applications did you conceive the KDT medplus rotary table machine presented at the Interpack 2014?

Jürgen Welker: The KDT medplus rotary table machine was specially designed for medical applications with a low throughput, say around five to ten products per minute. The packaging of knee and hip joints is a typical example of this. It is a semi-automatic machine in which the products are placed into the blister packs by hand. Of course, automatic product feeding can also be added if necessary and entirely in keeping with the modular machine design philosophy. An advantage for the end customer is that the KDT medplus makes do with only four tools, which keeps investment costs low and ensures short changeover times when switching products. The machine is automated via two NC servo

axes – AX5000 EtherCAT servo drives and AM8000 servomotors for the rotary table and the cover foil feeding – as well as around 80 I/O data points. The KDT medplus is thus a small system in comparison with our large machines, such as the current KOCH packagingLine for batteries with about 60 servo drives and 3,000 I/O data points.

Where do you see further optimization potential through PC control in future projects?

Jürgen Welker: In one of our current projects we are already using TwinSAFE as an integrated safety solution. We plan to implement this as standard in the future, because in the case of small systems with around 10 protective doors and large systems with up to 60 protective doors, an immense optimization potential arises in comparison to the previously used conventional safety technology. In order to investigate a switch to TwinCAT 3 we have successfully ported existing TwinCAT 2 projects with no great effort. We are expecting TwinCAT 3 to give us significant advantages in the modularization of our machines, in particular, through object-oriented programming.

Further Information:

www.koch-pac-systeme.com



Automating meat processing centers to be more flexible and precise

Highly efficient meat portioning using PC Control

TVI Entwicklung und Produktion GmbH in Irschenberg, Germany, makes machines and production lines for all areas of meat portioning and processing – ranging from meat tempering to transferring cut portions to packaging machines. TVI benefits from its own long-term expertise in the industry as well as from the performance and flexibility of the Beckhoff controllers and drivers it installs on its machines to meet the steadily rising requirements of customers with regard to process speed and accuracy.

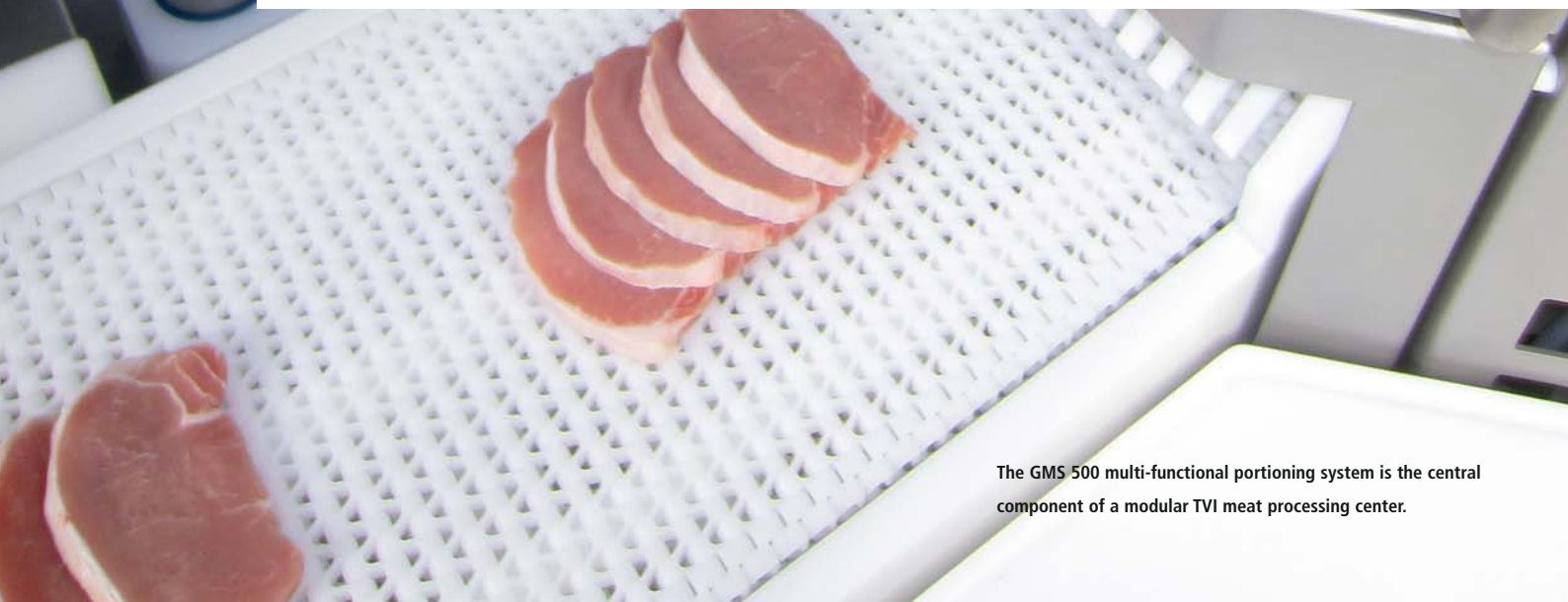

The GMS 500 multi-functional portioning system is the central component of a modular TVI meat processing center.

TVI machines are flexible meat processing centers that can be adapted to any portioning task with standard modules and customer-specific programs. Because the continuing consolidation of the food processing industry exerts enormous pressure to drive down costs, process efficiency is becoming increasingly important. Thomas Völkl, managing partner of TVI, references his company's motto to explain the rising requirements his company's solutions must meet: "Our machines portion any kind of red meat, of any consistency and cut type. We ensure optimum results in terms of weight accuracy and minimization of product waste along with maximum efficiency in terms of labor and energy." Just as important is the ability to offer comprehensive solutions for meat portioning and processing. This spectrum, says Völkl, comprises provisioning, tempering (warming up frozen meat and lightly freezing fresh meat), portioning (slicing, portioning, shingling), traying (manual or automatic), inspecting, and transferring the product to the packaging machine.

Machine expertise reinforced with flexible control technology

The use of energy-efficient and precisely controlled servo drives as well as pneumatic valves, which are optimized through precise and fast control, are just two examples of how demanding customer requirements can be fulfilled with PC-based control. This applies to individual machines as well as entire lines, as Thomas Völkl explains: "Thanks to our modular concept, we can build production lines with great flexibility from our individual components such as shock freezers, portioning machines and automatic tray fillers with tray dispensers and leftover disposal units. The modules are then linked with matching conveyors. By selecting the right individual components we can adapt the line to meet each customer's requirements. The control technology from Beckhoff has proven to be exceptionally flexible and suitable for all our applications – from the smallest system, the TDS 300 tray dispenser with just two pneumatic valves, up to the GMS 500 portioning system with its seven high-precision servo axes."

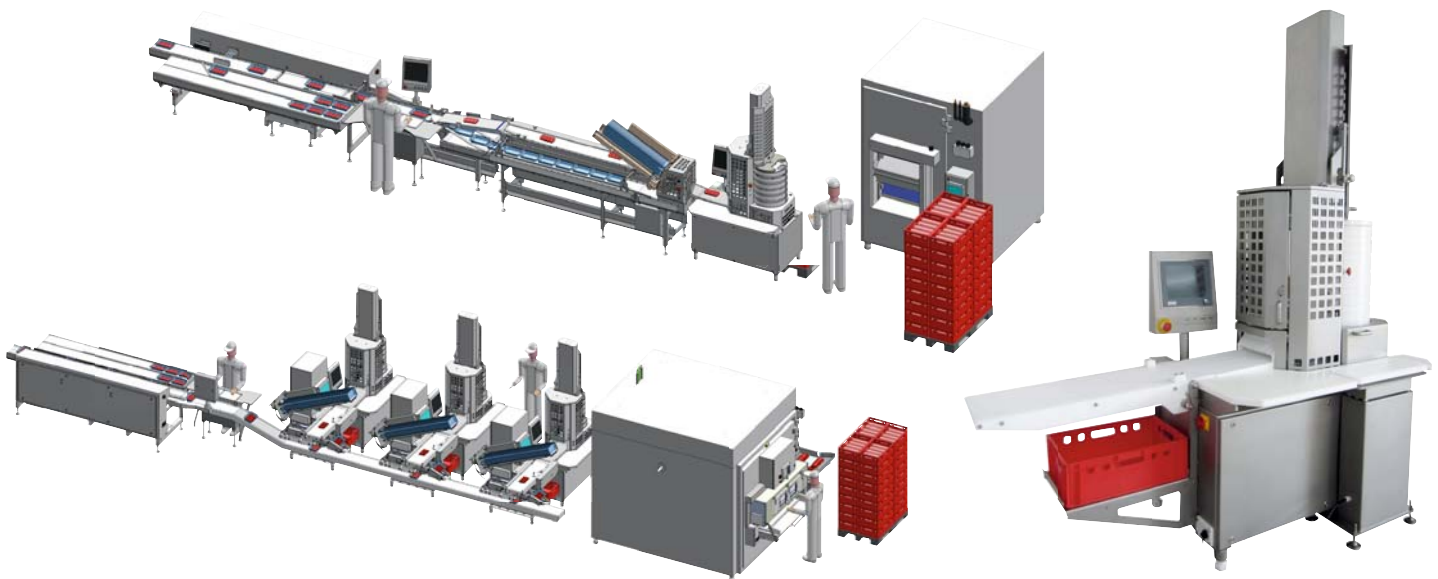

Both the Euroline (top) and the AIR Line (bottom) can be adapted to the customer's specific requirements.

The GMS 500 portioning system forms the core of a meat processing center.

Maximum energy efficiency is ensured in two ways: On one hand, servo drives replace most pneumatic and hydraulic actuators; this dramatically reduces the energy consumption of the machines. On the other hand, TVI's shock freezers are extremely efficient. Since the meat is removed seconds before the portioning process, the tempering crust needs to be only 2 to 3 millimeters thick and not 5 to 10 millimeters as is the case with most other systems. This cuts the energy consumption by roughly 80 percent. Most importantly, the shock freezer operates with conventional compressor-based cooling technology while most other systems continuously consume CO₂. This reduces the energy costs per kilogram of meat from the customary 5 to 10 cents to a substantially lower 0.4 cents.

The first component in a TVI meat processing line is the CBF Cyclefreeze, a rotary shock freezer. The meat is fed and discharged semi-automatically. Using a flap mechanism, the operator places the meat into one of the machine's baskets before pulling the drawer back again. The transport chain then advances the next basket. The CX9020 Embedded PC controller with its 1-GHz ARM Cortex™ A8 CPU moves the baskets through the freezer in such a way that the tempered meat is ejected after the specified time has elapsed (for example, 8 minutes). The shock freezer operator interface is implemented via a built-in, customer-specific CP6907 Control Panel that features a stainless-steel bezel and a flush 5.7-inch touch display. The panel is equipped with DVI/USB extension technology that allows it to be installed at a distance of up to 50 meters from the PC.



The portioning system (above) is operated via a customer-specific CP6901 12-inch Control Panel. The shock freezer (below) is operated via a built-in CP6907 Control Panel with a 5.7-inch screen..



Multi-functional portioning system is the heart of the line

At the core of most TVI meat processing centers and located directly adjacent to the shock freezer is the company's greatest revenue-maker, the multi-functional GSM 500 portioning system. The machine is controlled via a powerful CX1030 Embedded PC and TwinCAT NC I software. The Control Panel is an integrated CP6901, also with a stainless-steel bezel and a flush 12-inch touch display panel. Four compact AX5206 EtherCAT servo drives and five pole-wound AM3021 synchronous servo motors with AG2210 planetary-gear units ensure accurate motion control. Designed for highly accurate workflows, the GSM 500 carries out the following process steps:

- The operator places one or more pieces of meat into a mold.
- The machine rotates the mold to the cutting position and the appropriate piston is activated.
- The meat is perfectly formed and measured in the longitudinal direction.
- The machine portions the meat with no or minimal leftovers. The knife cuts the first slice after a linear unit has determined the slice's thickness in accordance with the target weight. The machine then continuously cuts the rest of the slices. Immediately after the last cut, the mold revolver moves the next piece of meat into position, and the process is repeated.

At the end of the meat portioning center sits the FPS 500 Euroline traying system, which places the meat into trays for catch-weight or fixed-weight portions. It consists of three coordinated modules: the MIS 3000-4000 manual inlay area with the TDS 300 tray dispenser, the automatic AIF 500 tray-filler, and the GMI 500 weighing and sorting unit. First, the portioned meat slices coming from the GSM 500 are placed on the conveyor belt of the MIS 3000-4000. From there they are placed into trays either manually or automatically with the AIF 500. The filled trays then move to the GMI 500, where they are buffered and weighed on a dynamic scale. Portions that are too light or too heavy are automatically pushed to separate buffer conveyors and moved to a rework station. Trays with correct weights continue directly to the packaging machine. All of these units are again automated with controller and drive technology from Beckhoff, such as the CP6901 12-inch control panel, four AX5206 EtherCAT servo drives and five AM3021 synchronous servo motors with AG2200 planetary-gear units.

Flexible and precise servo drives

The performance of servo drive technology from Beckhoff is evident in a wide variety of motion control tasks. In the GSM 500 portioning system, servo drives and servo motors ensure that the mold revolver and the spacer plate are rotated into exact position. The entire meat processing center operates with a wide range of rotating and pivoting movements – in the conveyor belts or the toothed-belt feeders for the trays, for example.

A special new development at TVI is the AIR 250 inlay machine with four servo axes that move a flap for leftovers, the conveyor and a so-called spring belt, and the toothed-belt feeder for the empty trays. On this machine, TVI also employs the new One Cable Technology (OCT) solution from Beckhoff where the feedback signals and power are directly transmitted via one cable. This eliminates the need for several wires and connectors on the motor and drive sides, resulting in significant component and commissioning savings. The OCT system is

implemented with two AX5206 servo drives and two AM8021 or AM8022 servo motors, each with AG2210 and AG2310 planetary-gear units.

Thomas Völkl believes that Beckhoff drive technology offers exciting potential for the future: "In our future developments we will integrate even more safety technology, and TwinSAFE offers a consistent system for drives and I/O with great implementation benefits. Accordingly, we will predominantly employ servo technology from Beckhoff."

PC Control offers speed and a broad spectrum of applications

TVI decided already in 2008 to replace conventional PLC technology with PC-based control systems. Thomas Völkl explains why: "Back then we ran into performance limitations, particularly when several synchronously operating axes had to be controlled. We initially programmed these applications in C++ and implemented them on an industrial PC. But we realized very quickly that the combination of PC and PLC technology slows the process down unnecessarily. Switching to an entirely PC-based control system was therefore an easy choice. Also, Beckhoff was the ideal supplier because their system is not only very fast, but open and extremely flexible." The Beckhoff system also allowed TVI to implement the necessary hydraulics controllers very effectively, adds Völkl. In addition, PC Control works equally well for small applications like the tray dispenser with its single air cylinder, vacuum valve and small control panel as it does for complex control tasks.

The flexible Beckhoff I/O system, with over 300 EtherCAT Terminals, opens up a wide range of applications and meets all of TVI's requirements. Its space-saving design is particularly important for Thomas Völkl: "Since our machines are very compact, the high density of the I/O terminal system is of great benefit for us. In our shock freezer, for example, we employ the EL2809 EtherCAT HD terminal, which features 16 digital outputs in a housing that is only 12 millimeters wide." Other benefits include the many terminals with special integrated functions. The EL3356-0010 dynamic scale sensor, for example, will make it easier to integrate the weight into the machine control, while EL34xx power monitoring terminals will document the shock freezer's low energy consumption.

For Völkl, the term systems supplier also covers another important aspect: "Beckhoff delivers the entire control technology pre-assembled in control cabinets as a value-added service. This is a huge benefit for us, because we no longer have to keep these components in inventory – unlike in the past, when we worked with a supplier who did nothing but build control cabinets. The fact that electrical and electronic components account for 30 to 50 percent of a machine's value today demonstrates how important this has become."

New TwinCAT 3 software generation offers higher potential for more efficiency

Thomas Völkl wants to continue on the successful path of making his machines and systems more modular in order to enable more efficient customization of meat processing centers with as little engineering effort as possible. The mechanics are already quite advanced, but the software development still has the potential to become even more modular,



Thomas Völkl, managing partner of TVI Entwicklung und Produktion GmbH in Irschenberg, Germany, shows off the multi-functional GMS 500 portioning system.

says Völkl. He believes that the new TwinCAT 3 software generation offers the right tools to increase efficiency: "Having the kind of object-orientation that TwinCAT 3 supports so effectively is essential for making electronics and programming more modular. TwinCAT 3 delivers two major benefits: object-oriented programming requires a lot less effort and it easily accommodates multiple developers' work on the same project simultaneously. That's why we will implement TwinCAT 3 on the next generation of our portioning machines."

Further Information:

www.tvi-gmbh.de



PC- and EtherCAT-based control improve the performance and flexibility of packaging machines

Bosch Packaging: Traditionally innovative



For over 70 years, Bosch Packaging Technology Inc., based in New Richmond, Wisconsin, has employed state-of-the-art technology in its products. Since 2004, the company has used the PC- and EtherCAT-based Beckhoff control platform on most of its product lines. With its CCM 3100, Bosch Packaging has introduced a modular case packer for the food and candy industries to the U.S. market that fits seamlessly into a fully automated packaging line. Other benefits of the CCM 3100 include its exceptional operating efficiency, its ease of use and flexibility during product changeover.

Bosch Packaging Technology, which is part of Germany's Bosch Group, was originally a well-known developer and producer of band sealers under the Dobby name in the 1940s. The company's products made it possible to package cereal products in cellophane bags to keep them fresh. Today, Bosch Packaging specializes in serving the food and snack industries. Its wide-ranging product portfolio includes machines for horizontal and vertical bagging applications, closing and sealing units, forming and sealing machines for boxes or trays, as well as feeder systems and pick-and-place robots. Typical applications include the packaging of fresh and frozen foods, cereals, snacks, candy, pasta, rice, flour, coffee, pet food, and many more.

More flexible forming, filling and sealing operations

As one of the highlights at Pack Expo 2013 in Las Vegas, Bosch Packaging Technology introduced its newly developed CCM 3100 case packer, which fits seamlessly into vertical and horizontal bagging lines. The CCM 3100 accelerates production workflows and improves the flexibility of the packaging process. "With its ability to be combined with other Bosch packaging machines, the CCM 3100 expands our portfolio of flexible and adaptable secondary packaging solutions that can be tailored to the users' needs with regard to bag shapes, ready-to-display arrangements and packaging formats," explains Craig Collett,



Capable of picking and placing up to 180 bags per minute, the Bosch CCM 3100 machine's single frame is attached to an infeed system that accepts products from VFFS and HFFS primary packaging machines

director of HFFS and secondary packaging systems at Bosch Packaging Technology. The CCM 3100 handles a broad spectrum of bag and box sizes and types, including regular-slotted containers, half-slotted containers and other shelf-ready packaging styles.

To be able to pick and place up to 180 bags per minute, the machine's single frame is attached to an infeed system that accepts products from VFFS and HFFS primary packaging machines. Depending on their properties, the products can be handled individually or in groups. They are picked and placed by a dual-axis robot with vacuum nozzles or gripper end effectors. The setup of the CCM 3100 can be quickly changed to accommodate vertical or horizontal bag orientation, a different bag recipe or a different machine configuration. The machine's data storage capacity makes this possible by providing room for over 1,000 recipes as well as a recipe wizard.

The open frame of the CCM 3100 also ensures easy access for quick and tool-less setup changeovers along with high production capacity. A built-in inspection station on the infeed conveyor lets the user control the quality prior to the packaging process and makes sure that all bags are properly shaped and aligned for easy boxing. "Built for ease of use and long life, the CCM 3100 can run 24 hours a day, seven days a week, with operators being able to switch quickly between vertical and horizontal packaging modes in order to optimize the secondary packaging process," says Collett.

PC-based control platform as an established standard

Bosch Packaging Technology started employing Beckhoff control devices in 2004. Since then, the company has implemented CX-Series Embedded PCs and EtherCAT I/O technology in several generations of its machines. The CCM 3100, for example, features a robust CX5020 with a 1.6-GHz Intel® Atom™ processor as its central automation and motion control platform and uses EtherCAT to communicate with its servo drives. The CX5020 is connected to a control panel for machine operation, recipe management and troubleshooting. Machine controls and robot programming are handled via TwinCAT automation software. The system can also communicate with older machines via the TwinCAT virtual serial driver software. "For most applications, Bosch Packaging has developed a standard control solution on the basis of the CX5020 Embedded PC and EtherCAT that is being used on many of our machine lines," says Phil Koehler, engineering manager at the company. "Bosch Packaging Technology has standardized on EtherCAT as bus system because of its high speed and broad acceptance in the market, as well as its wiring flexibility and ease of implementation."

Another benefit of the Beckhoff control platform, adds engineering manager Koehler, are its 16-channel high-density (HD) terminals, which reduce the electrical cabinet space requirements for the machine's I/O equipment by up to 75 percent: "The HD terminals contribute to the machine's smaller footprint, which is increasingly becoming a selling point. Using EtherCAT and the CX5020 enables us to offer a control system with exceptional performance and flexibility at a competitive price point."

Joe Franek, engineering supervisor at Bosch Packaging Technology, agrees: "Beckhoff is currently the standard PC control platform for most of our product lines ranging from horizontal and vertical form, fill and seal machines to delta

The CCM 3100 packer uses a CX5020 Embedded PC featuring a 1.6-GHz Intel® Atom™ processor as its central automation and motion control platform.



robotics to box forming and closing.” Phil Koehler summarizes: “By utilizing a PC-based motion control system with EtherCAT we are able to achieve faster scan times and higher axis counts in our motion systems. And we accomplished

all of this while at the same time reducing our control costs when compared to our previous PLC vendor.”

The new CCM 3100 case packer from Bosch Packaging Technology is designed to increase flexibility in secondary packaging, meeting manufacturers’ needs for shorter production runs and more frequent changes in packaging styles.



Further Information:

www.boschpackaging.com

www.beckhoffautomation.com



The Metis™ continuous motion machine is one of the latest technological developments from Matrix Packaging.

Matrix Packaging: PC Control, EtherCAT and AM8000 servo motors with One Cable Technology save cabinet space and reduce costs

Vertical form-fill-seal machine: PC-based control technology provides compelling advantages

Matrix Packaging, based in Saukville, Wisconsin has over 20 years of experience in developing vertical form-fill-seal machines. The company's new Metis™ model, which was unveiled at Pack Expo 2013 in Las Vegas, sets new milestones in efficiency and performance. With its PC-based control technology, the machine can flexibly fill between 1 and 180 bags per minute, depending on the product and the packaging line.

"The new Matrix Metis represents a new generation of vertical form, fill and seal (VFFS) machines," says Marc Willden, Vice President & General Manager of Matrix Packaging Machinery. "The Metis was designed for the diverse needs of the food industry, in which we have a strong position, and is ideal for packaging cheese, coffee, snacks, candy, etc." Matrix customers also include companies that package items such as hardware for home improvement stores.

"What makes the Metis so special is the fact that it operates with continuous motion, which significantly increases its capacity and throughput. On the other

hand, it also requires a much higher degree of automation," explains Willden. Because the bag film moves continuously, the mechanical jaws that seal the bags operate on the fly as well, synchronized via EtherCAT. The Metis is particularly well suited for the processing of small and thin bag films at high speed. Depending on the line, the machine is able to process between 1 and 180 bags per minute. This level of flexibility ensures the best possible product flow and higher quality packaging.

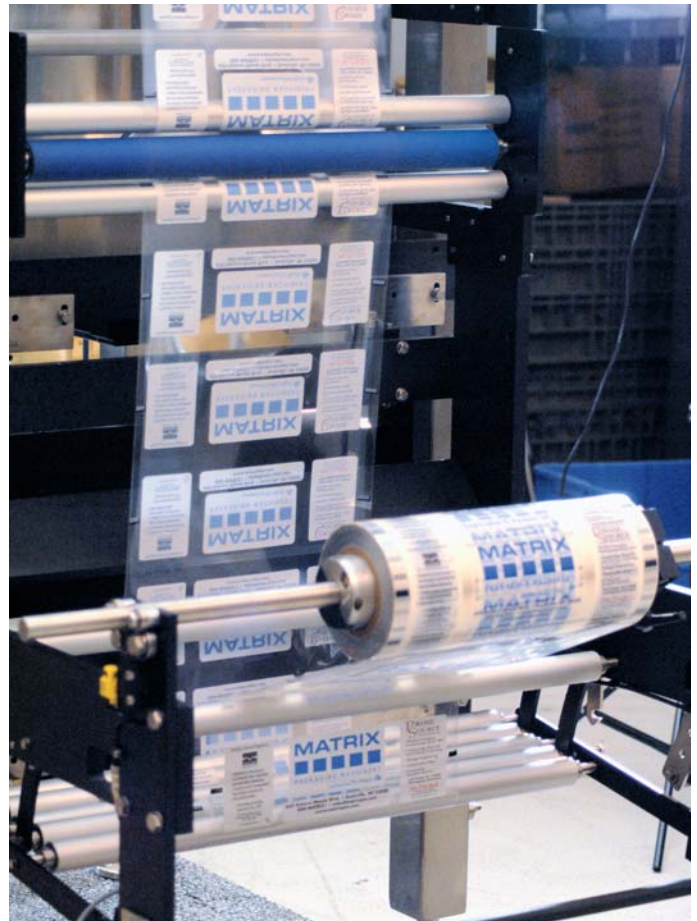

Depending on the line, the vertical form-fill-seal machine can process between 1 and 180 bags per minute.

Standardization based on PackML enables easier engineering and creates transparency

The control system architecture consists of a CX5020 Embedded PC, an integrated 15-inch CP2915 multi-touch Control Panel, EtherCAT I/O terminals, AX5000 EtherCAT servo drives and AM8000 servo motors with One Cable Technology, as well as TwinCAT NC.

The result is a state-of-the-art machine on the basis of the OMAC PackML standard. "Since October 2011 Matrix Packaging has been part of the Pro Mach group, which has over 20 brands dedicated to packaging technology. Pro Mach is a big believer in the PackML standard. With features like standardized operating mode management and communication structures, PackML provides immediate clarity. It also reduces the engineering and integration costs, increases productivity, and provides improved diagnostics. All these benefits deliver real added value to our customers," says Marc Willden.

Modern multi-touch HMI concept

"We decided to use multi-touch technology because of the bright, high quality displays that are available from Beckhoff," says Mike Krummy, who is in charge of electrical engineering at Matrix Packaging. He adds: "PackML requires a fairly large user interface, and implementing this on a traditional 6-inch screen would have been difficult. The Metis is now equipped with a 15-inch diagonal

multi-touch screen, the CP2915, at nearly the same cost as our previous panels, which were much less elegant with their single-touch interface and conventional plastic housing." The Matrix Packaging team is highly impressed by the multi-touch functionalities such as the enhanced ability to scroll and use two hands. "If an operator has accidentally removed the protective barriers on the machine, his hands are always in a safe position, even when the machine is running," as Krummy points out.

Integrated platform for PLC, motion control and visualization

The compact, DIN rail-mountable CX5020 Embedded PC serves as the integrated platform for PLC, motion control and visualization. It controls all the programs that facilitate the communication with downstream components on the line, synchronize the feeder with the Metis machine processes, trigger the mechanical bag sealing jaws, etc. It also controls the two AX5000 EtherCAT servo drives that handle three axes of motion. Matrix Packaging only needed two servo drives to run three motion axes by utilizing a 2-channel AX5000 drive and a 1-channel AX5000 drive. The motion profile is implemented via the NC camming function, which is part of TwinCAT.

OCT reduces cabling

"By selecting servo motors from the AM8000 series with One Cable Technology (OCT), we streamlined the motion control even more. OCT is efficient and fits into our machine concept," explains Mike Krummy. "Through the use of One

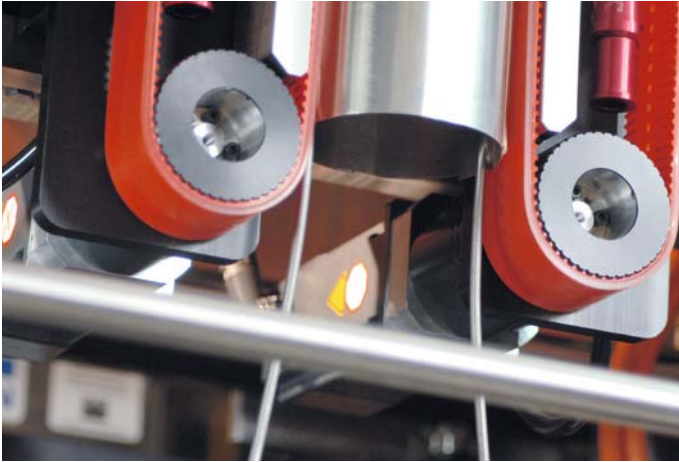

By leveraging One Cable Technology from Beckhoff, Matrix Packaging was able to reduce its motor cabling by 50 percent.



The high-quality 15-inch Control Panel with modern multi-touch technology is another highlight of the Metis™.



One CX5020 Embedded PC controls the entire machine, including motion control and visualization. The motion system has been implemented using AX5000 EtherCAT servo drives and AM8000 servo motors with One Cable Technology.

Cable Technology and the elimination of several smaller parts, our cabling effort has been reduced by 50 percent.”

EtherCAT delivers unlimited expandability and interoperability

In addition to the high performance of EtherCAT as an I/O and motion control bus system, Matrix Packaging appreciates the system’s expandability and interoperability as well as the wide range of EtherCAT I/O terminals for special functions. One of these is the EL3681 digital multimeter terminal for cost-effective power supply monitoring. “For example, if an operator runs the VFFS machine with insufficient voltage, an alarm monitor triggers an emergency stop and reports that there is a problem with the power supply,” explains Mike Krummy. “Compared with a separate stand-alone solution, the integrated terminal is a much more cost-effective option.”

Any concerns that the machine controller and fieldbus won’t be able to keep up with the inventiveness and development potential of Matrix Packaging are now a thing of the past. “It’s quite impressive that our Metis machine uses less than 1 percent of the new control platform’s capacity,” adds Marc Willden. “The PC-based controller and EtherCAT have plenty of reserves for all future requirements.”

New platform saves space and money

Reducing the footprint of machines is another major goal of Matrix Packaging that was achieved by using the Beckhoff control platform. Taking advantage of the compact design of the control components, the electrical cabinet of the Metis is roughly 6 inches (15 cm) shorter than that of the prototype, which was equipped with a traditional PLC. “Control cabinet assembly takes much less time now, not just because of the One Cable Technology of the motors, but also because of the intelligent design of the EtherCAT Terminals. EtherCAT has reduced our control cabinet wiring costs by 30 to 40 percent,” says Mike Krummy.

“Although the Metis delivers much more performance and functionality, the PC-based controller costs us approximately 10 percent less than the originally planned PLC solution – even with the addition of the multi-touch user interface,” says Marc Willden. “The Beckhoff approach to automation with its focus on accepted standards is similar to the philosophy of Matrix Packaging. We avoid using any proprietary mechanical or electrical components, as we prefer standard products and technologies that are proven in the industry.” Accordingly, Matrix Packaging is thinking about migrating additional machine lines to the PC Control platform from Beckhoff.

Further Information:

www.matrixpm.com

www.beckhoffautomation.com

Multi-touch panel redefines machine operation

Edson Packaging turns the page to a new era of multi-touch enabled machinery



Edson Packaging, based in Hamilton, Ontario, Canada, specializes in packaging machines for a wide range of industrial applications, but particularly for paper and tissue products, food products, pharmaceuticals, and consumer goods.

Through smartphones and tablets, virtually everyone is familiar with intuitive interfaces with multi-touch display functionality. Following this trend, Edson Packaging Machinery Ltd., a Canadian manufacturer of case packaging systems, now employs multi-touch panels to once again solidify its reputation as a company that leverages the power of modern technologies.



Right: With gestures for zooming in, scrolling and paging, multi-touch technology features the same ease of use as smartphones and tablets.

With its IntelVüe and multi-touch technology, Edson Packaging improved not only the user interface and access to machine data, but the level of operator safety. The operator can monitor the machine and make many adjustments via the Control Panel.

Edson Packaging, based in Hamilton, Ontario, specializes in case packers for a wide range of industrial applications, but particularly for paper and tissue products, food products, pharmaceuticals, and consumer goods. Since 2012 the company has been part of Pro Mach Inc., one of the largest packaging machinery consortiums in North America.

Innovative operating concept

With its IntelSuite™, Edson has introduced a series of solutions to the market that support various forms of machine connectivity in the packaging industry. Based on the near-field communication (NFC) standard, IntelLink provides direct access to videos, PDF files and pictures as well as wireless telephone contact with Edson Packaging's customer service department. Users simply tap on their NFC-capable smartphone or tablet to display the desired information. IntelVüe transmits live videos to the CP3924 Multi-touch Control Panel via a standard webcam. The Edson solution also includes an RFID-based tracking system for machine tools that makes sure the correct tool is mounted on the machine, thus avoiding costly problems and downtime.

The SR3550 high-speed horizontal case packer features a 24-inch CP3924 Control Panel with multi-touch technology. "This panel recognizes the same gestures for zooming in, scrolling and paging that people are already familiar with from their consumer devices," explains Brianne Moar, who handles sales and marketing at Edson Packaging. "The installation of IntelVüe in combinati-

on with the HMI software on the C6930 Industrial PC allows us to store many different types of files. For example, we can save videos and make them available for the machine installation process as well as for training, operator guidance or troubleshooting. Live videos that display machine processes can also be implemented."

The C6930 Industrial PC features a third-generation Intel® Core™ i7 processor (2.3 GHz, 4 cores). "This powerful IPC has been designed to perfectly meet Edson Packaging's requirements with regard to vibration and heat resistance," says Calvin Wallace, sales manager for western Ontario at Beckhoff Canada. "The C6930 is not only compact and saves cabinet space, it also includes various options for SSDs. Edson employs a 64-GB SSD in their C6930, which increases its stability and reliability considerably while delivering immense storage capacity."

Easier to use with more functionality

"The five-finger multi-touch capability of the display panel enabled us to significantly expand the functionality of the user interface and add useful functions such as dials for servo axis control, fine-grained speed adjustments, etc. Another feature is the ability to use both hands on the screen," adds Jeff Werner, vice president of technology at Edson Packaging. "Particularly important for us is the fact that we can easily integrate videos and various machine data into the user interface with IntelVüe. By leveraging the high resolution of the 24-inch panel we can even display informative trend information on the screen. By



integrating various multimedia applications, Edson offers its customers a great deal of added value,” says Werner. The elegant design of the Beckhoff Control Panels was another critical factor for Edson: “Like our customers, we prefer slim displays. Also, the 24-inch screen features a much larger interface area than traditional single-touch control panels.

Multi-touch panels add safety

With its IntelVüe and multi-touch technology, Edson Packaging improved not only the user interface and the access to machine data, but the level of operator safety. Since webcams and/or high-speed cameras provide a large amount of information on the Control Panel, operators have to enter the machine much less often to change the setup or perform maintenance. They can see many of the operations safely from the outside on the CP3924 Control Panel.

The fact that the operator can observe the machine’s operation without having to pass protective barriers also means that various servo motors have to be shut off much less frequently. Having fewer ON/OFF cycles means that the machine components last longer. “Because of the video feed images on the CP3924, the number of ON/OFF cycles has dropped by at least 25 percent,” explains Jeff Werner.

Further Information:

www.edson.com

www.beckhoff.ca



Interview with Erwin A. Fertig: The packaging industry is characterized by customized machine designs

Motor design with packaging in mind

With a global market share of 22 percent, Germany is (according to German Engineering Association VDMA) the world leader in packaging machine engineering, followed by Italy with 16 percent, the United States with 12 percent, Japan with 10 percent, and China with 6 percent. Because the market is split into food, pharmaceuticals, chemicals, cosmetics and non-food segments, the packaging industry is highly diverse. Accordingly, it is dominated by medium-sized, specialty machine builders which are frequently owner-operated, who custom-design most of their products for the respective goods being packaged or the application. The market's size and wide spectrum of requirements also make it quite attractive for suppliers of automation technology.

Automation for packaging technology

The importance of electrical automation technology in packaging machine engineering became apparent quite early. In the early 1990s, while I was still the owner of Elau AG, machine designs began to move from mechanical drive solutions (upright shafts) to electrical drive technology. The trend towards combining PLCs with motion control units, or different programming platforms, also started at this time. These approaches can be optimally implemented today using PC-based control solutions from Beckhoff.

There is still plenty of room for growth for suppliers of modern drive and control technologies. The global packaging market keeps growing at an annual rate of 5 percent, with significant increases expected due to the integration of actuators and sensors in the field.

Motor development with built-in packaging know-how

Fertig Motors GmbH was founded in March 2010 as a joint venture with the Beckhoff Group. Our goal was – and still is – to develop the latest generation of innovative servo motors that feature exceptional dynamics, energy efficiency and cost-effectiveness, and to design them especially for PC- and EtherCAT-based control technologies from Beckhoff. Needless to say, the vast experience we gained in the demanding packaging industry contributed a great deal to the features now included in these new motors.

When you develop servo motors for packaging machines, it is particularly important to deliver the right ratio of inertia and peak torque. Since the mostly non-continuous movements in packaging processes are frequently characterized by rapid acceleration and rapid braking, we paid special attention to these requirements when we developed the Beckhoff AM8000 series servo motors. These advanced motors feature One Cable Technology (OCT), which

combines the feedback and power systems into one cable. Most packaging machines are run in two-shift or three-shift environments, which is why we also built these Beckhoff motors with extra-strong motor shafts and bearings. Also, with the typically very large number of servo motors in a packaging machine, giving them plug-and-play capability reduces commissioning time and costs. For us, "plug-and-play" means giving the motor an electronic name plate so that the drive controller receives all motor data automatically.

In addition to the standard AM8000 series, we introduced the AM8800 stainless steel servo motor series. It meets EHEDG requirements and is used predominantly in the pharmaceutical and beverage industries to facilitate high pressure wash cleaning procedures and prevent the build-up of bacteria.

Industry 4.0: Communication from the drive to the web

The packaging machine industry, which must continuously adapt to changing package designs and shapes, is an ideal proving ground for Industry 4.0 concepts. Accordingly, the packaging machine of the future must meet a demanding set of requirements. It must be intelligent, quickly adaptable, and efficient. The production processes should even be controllable by the products themselves and for this purpose provide web connectivity. This requires machines to have actuators and sensors that are fully automated and able to communicate with one another. Accordingly, many primitive motors and actuators that currently don't have these capabilities will have to be replaced with modules that can be integrated into the automation network. With PC-based control and EtherCAT, and the matching drive technologies, Beckhoff already offers fully vertical and horizontal integration capabilities today, thus providing the ideal platform for Industry 4.0 concepts in the packaging industry.

Erwin A. Fertig, Managing Director Fertig Motors GmbH



Galdi: PC-based control meets all requirements for modular packaging machines

Twelve-thousand cartons filled with fresh milk per hour

The strength of Galdi's packaging machines is their high flexibility: The filling machines can fill 1,000 to 12,000 gable-top cartons per hour with carton base measurements ranging from 57 x 57 mm to 95 x 95 mm and volumes ranging from 250 milliliters to 2 liters. In order to be able to meet the high requirements in the packaging market regarding openness towards common standards, flexibility and reliability the machine builder chose to employ PC-based control from Beckhoff. With this modular control technology Galdi can adapt its standard machine designs quickly and easily to varying customer specifications.





Galdi offers a broad portfolio of filling machines for milk, dairy products and fruit juices.



Company founder Galdino Candiotto. His success story began in the 1970s, when he developed a filling machine for the dairy owned by his family.

It all started over 40 years ago, when Galdino Candiotto developed a semi-automatic filling machine to make the milk packaging operation in his family-owned dairy more efficient. When other milk producers who also wanted to automate their filling operations besieged him with inquiries about his invention, he decided to enter the machine manufacturing business. Today the company employs 70 people and exports 90 percent of its machines all over the world. Galdi's core business consists of equipment for filling gable-top cartons of many types with a wide range of dairy products, fruit juices, as well as liquid and semi-liquid food products. The company's wide product portfolio also includes machines for filling plastic (PET) bottles and cups.

Standard model fulfills individual customer requirements

"For us, as a maker of packaging machines, the challenge involves creating ever more powerful and customized machines in a market that demands flexibility and user-friendliness," explains Galdi marketing manager Alessandro Ferraris. "Our key technology is the filling machine – its modularity enables our solutions to meet the widest possible range of customer requirements." Galdi sells a broad portfolio of standard machines with a modular design that can be adapted to each customer's specific needs. This approach makes it possible to deliver "quasi-customized" models at the price of a standard machine.

"Our machines cover a wide performance range from 1,000 to 12,000 cartons per hour, with various container formats and volumes. While the basic chassis of the machine remains unchanged, we can meet the customer's individual requirements by integrating additional modules such as those for filling cold milk or warm fruit juices, for ultra-clean filling applications (UCS), or for applying screw-caps," explains Ferraris. "The openness of the PC Control solution from Beckhoff matches our approach perfectly."

To deliver constant quality on time and be able to accommodate future requirements, Galdi operates in accordance with the "lean thinking" concept. "This also applies to the project and product development phases," emphasizes Alessandro Ferraris. "That's why we work only with partners who support this approach, that is, we expect from them the same level of openness and flexibility that our customers expect from us."

PC-based control meets all requirements in terms of openness, flexibility and modularity

Galdi is currently developing two new filling systems for gable-top cartons that are equipped exclusively with Beckhoff control technology. "We looked at several control technology providers, but when tests of Beckhoff's controller platform delivered consistently positive results in several beta projects, we decided to deploy this solution in future developments," says Ferraris.

A control cabinet with a C69xx Industrial PC running TwinCAT 3 automation software, a CP6902 15-inch "Economy" control panel, three local EtherCAT terminal stations with a total of 450 I/Os, and four AX5000 EtherCAT servo drives for controlling seven motors are used as an integrated platform for PLC, motion control and HMI applications. Galdi uses EtherCAT as its communication system and Safety-over-EtherCAT for highly secure safety communication.

The system meets all of Galdi's requirements, which included a fanless PC platform with an embedded operating system and solid-state storage media,

- 1) The Ultra Clean System (UCS), which was developed in cooperation with the University of Udine, makes it possible to fill and sterilize containers in a monitored ultra-clean environment in order to make products last longer.



Marketing Manager Alessandro Ferraris at Galdi: "For Galdi, the challenge involves producing ever more powerful and highly customized machines in a market that demands flexibility and user-friendliness. We chose to work with Beckhoff as our partner, because the openness of their PC-based control solution fits perfectly with our approach."

the ability to upgrade software, firmware and setups via memory modules without external devices. Other needs included the ability to decentralize peripherals for applications like motion control, which reduces control cabinet size, using a real-time Ethernet fieldbus, compliance with the IEC 61131 and PLCopen programming standards, axis control with support for advanced algorithms, as well as the possible integration of advanced safety systems. "The openness and flexibility of the Beckhoff solution is also reflected in our ability to use motors from other manufacturers if the customer makes such a request," says Alessandro Ferraris.

Another feature in favor of the Beckhoff technology were the company's stainless-steel motors, providing a hygienic design according to EHEDG guidelines, which makes them ideal for use in food packaging applications. "On top of all that, the One Cable Technology of the Beckhoff drive technology reduces our wiring costs," adds Ferraris.

"In addition, the TwinCAT development environment provides excellent debugging features that enable us to trace all signals and the corresponding alarms clearly and completely. One of the absolute strengths of the Beckhoff solution, however, is the potential prototyping, i.e. the development and testing in the project phase, which has turned out to be a fantastic benefit for us," adds Alessandro Ferraris.

The format and volume of the gable-top carton are the most relevant parameters for the filling process. "With the standard carton base dimensions of 70 x 70 millimeters, for example, we can handle volumes ranging from 250 milliliters to 1 liter on a single machine. The customer can run various filling processes with great flexibility and does not even have to initiate cleaning procedures when



An intelligent metering system with a flow meter makes it possible to package liquids like milk or fruit juice, while a piston-based high-viscosity metering system is available for semi-liquid products like yogurt.

the carton size is the only thing that changes," explains Galdi's marketing manager.

"The Beckhoff PC-based control platform provides not only the necessary flexibility, but also the precision and repeatability which make our 100 % compliance with the customer's required tolerances possible," explains Ferraris. This kind of performance improves Galdi's strategic position in the highly competitive packaging equipment market, but that's not all: in addition to an attractive price-to-performance ratio, the complete openness for the world's most important standards, the flexible and user-friendly development environment, and the ability to integrate even proprietary software without losing any know-how are additional reasons why Galdi owner Galdino Candiotto is so pleased with his partnership with Beckhoff.

Further Information:

www.galdi.it

www.beckhoff.it



PC-based control solution powers blister packaging machine for the pharmaceutical industry

PC Control for fast, error-free and compact pill packaging

Switzerland's Rohrer AG exclusively employs PC-based control systems from Beckhoff in its new R760 blister packaging machine, which was designed especially for the pharmaceutical industry. By leveraging the powerful and highly accurate EtherCAT I/O system and the dynamic and compact drive components from Beckhoff, Rohrer was able to develop a machine that operates not only in a fast and error-free manner, but takes up very little space.

Rohrer AG specializes in machines for developing and configuring flexible films and foils and the products made from them. To produce its customized tools and machines, the company works closely with its customers from the initial idea to the final realization. Its support services range from developing samples, to building prototypes, to configuring the production equipment.

Modular blister packaging machine

The customizable R760 machine is used to produce packaging for small to medium lot sizes. It can be used for all stages ranging from the development to the mass production of blister packs from flexible film. The machine handles the entire manufacturing process, meaning it can thermoform, seal, perforate

The R760 machine covers the entire manufacturing process, i.e. it can thermoform, seal, perforate and stamp blister packs.



The powerful PC-based control technology from Beckhoff allowed Rohrer to achieve an output rating of 40 double blister packs per minute for the first time with its R760 machine.

The new R760 blister packaging machine from Rohrer serves as a development platform for the packaging of so-called orally disintegrating tablets (ODTs).



and stamp blister packs. Camera systems inspect the packs to ensure that they are properly filled and automatically discharge any rejects. If space is tight, the number of machine modules can be reduced. And thanks to its GMP-conforming design (good manufacturing practice), it is even suitable for installation in cleanrooms.

The R760 blister packaging machine can process aluminum foil and plastic film for pharmaceutical, cosmetics and healthcare applications. The project being covered here involves a machine used by a large packaging service provider for the pharmaceutical industry. The machine is used to evaluate new products and packaging types. The pills being packaged in this case are so-called orally disintegrating tablets (ODTs), which are freeze-dried with the patented Lyopan process and can be taken without water. The machine's design and automation

technology had to meet extra-high requirements in terms of speed and size. The result was the first system featuring 40 cycles, i.e. an output capacity of 40 double blister packs per minute.

All control technology is PC-based

Rohrer gained its first experience with PC-based control technology from Beckhoff as early as 2008, when the company installed integrated CP6200 Panel PCs and cabinet-mounted C6920 Industrial PCs (IPCs) for the first time. In 2012, Rohrer decided to switch completely to PC Control. Bernd Esch, controls manager in Rohrer's Processing & Packaging unit, explains the reasons: "The previous control architecture had a few disadvantages. For example, it required multiple bus systems. Ensuring that the safety technology met the performance level required by the EN ISO 13849

As the all-encompassing control solution for the R760, PC Control handles all the safety functionalities and the Ethernet communication.



standard was also quite complex. In addition, customers demanded more compact systems – something we would not have been able to provide with the relatively large drives at the time and the additionally required EMC filters. The AX5000 drives from Beckhoff, on the other hand, are very compact and include integrated EMC filters. They reduced the cabinet space by roughly 30 percent.”

In addition, the CP6200 display Panel PCs and the C6920 IPCs already provided sufficient computing power for the automation tasks. Bernd Esch continues: “The TwinCAT automation software offered not only the required PLC functionality, but also a powerful software-based NC system. This meant that we did not need an extra controller besides the space-saving IPC from Beckhoff. I should also mention that Beckhoff Switzerland provided us with very good local application support for the PC Control solution.”

Another significant advantage, says Esch, is the openness of PC Control: “We must be able to connect our machine controllers to any network. The broad spectrum of EtherCAT Bus Couplers and fieldbus terminals gives us complete flexibility in this regard. We can also communicate easily with the IT system, because with the integrated Ethernet interface and the TwinCAT ADS layer we can call up any control data we need without having to make a change in the PLC program.” Connecting the visualization system was just as easy, because – like most systems on the market – it already had a driver for TwinCAT. The communication with Java-based programs for the web visualization and with a MySQL database for things like batch parameters and error messages also works extremely well, says Esch.

At the core of the PC Control solution for the R760 machine is the C6920 control cabinet IPC with its 1.9-GHz Intel® Celeron® processor, multilingual Windows

XP Professional operating system and TwinCAT NC PTP. The operator controls the machine via an arm-mounted CP7902 Control Panel that features a 15-inch touchscreen, customized screen film and a customized keyboard extension. The motion control functions are performed by eight servo drives of types AX5112, AX5140 and AX5206, including an AX5805 TwinSAFE card, and 10 servo motors from the AM8000 series. The roughly 150 I/O data points are collected by approximately 100 EtherCAT analog/digital and TwinSAFE terminals and are integrated into the control technology via four EK1100 EtherCAT Couplers.

Highly dynamic drives require minimum installation effort

Besides being very compact, the servo drive technology from Beckhoff features outstanding dynamic characteristics, says Bernd Esch: “By adjusting the production parameters accordingly, we were able to quickly achieve the exceptionally high output of 40 double blister packs per minute. We did this without reaching the limits of the machine’s servo drive technology.” Rohrer achieved this level of performance with the help of AM8000 high-performance motors, which are characterized by their low rotor inertia and up to five-fold overload capacity. They drive three servo axes for opening and closing the presses, two axes for the foil transport, one axis for feeding and positioning the trays into the machine, two axes for handling the blister output, as well as adjustment axes that move the processing stations into their proper position relative to the product.

Rohrer also benefitted substantially from the One Cable Technology (OCT) made by Beckhoff, which combines the power supply and the feedback system into a single motor cable. The single-cable solution transmits the information reliably and protected from interference via a digital interface. This eliminates the need for wires and connectors on the motor and controller sides, which in turn produces significant component and commissioning savings. Bernd Esch realized this

With the customized design of the CP7902 Control Panel, Bernd Esch, Controls Manager of Rohrer AG's Processing & Packaging Technology unit was able to optimally implement his requirements.

Through the use of Beckhoff drive technology with one-cable technology (OCT), Rohrer was able to design an uncluttered control cabinet and reduce its installation and material costs by approximately 25 percent.



as well: "With its reduced cabling requirements, OCT delivered huge savings for us, particularly since two drives employ power track chains. It enabled us to make everything a little smaller, which also helps with the overall machine design. All in all, OCT reduced our installation and material costs by roughly 25 percent. It also makes the commissioning process a lot easier. In the past, running a completely new encoder line was the standard solution when malfunctions occurred. Now that they are integrated into the motor cable, we no longer have to engage in long discussions about rerouting the wiring."

Integrated safety technology provides new options

Other features that simplified the engineering of the machine are the automation system's integrated safety functions, ranging from the TwinCAT Safety Editor to the Safety over EtherCAT communication protocol to the TwinSAFE terminals and the AX5805 TwinSAFE drive option card. They allowed Bernd Esch to design the safety functionalities with much more flexibility: "We can design the safety system with much more openness. For example, each safety door now has its own TwinSAFE terminal, which eliminates the previously common serial connection of safety switches or emergency stops."

The flexibility of the TwinSAFE system also simplifies the selective execution of safety functions for individual machine modules. For example, certain machine components can remain "live" when the machine starts up, while others are safely shut off when a safety door is open. Bernd Esch: "Implementing something like this was extremely difficult in the past and only possible with enormous amounts of wiring. With TwinSAFE we can handle this with a much more elegant and compact solution that also requires fewer components and costs less."

Speedy and highly deterministic control technology delivers precision

The foil used to seal the trays and the trays themselves have fiducials (visual reference points) which are read as they move through the machine. Depending on the relative position of the tray, the machine reads the exact end position in the conveyor system and computes the relative position of the processing units. Through the use of fast EtherCAT communication components, Rohrer was able to move the products at the high speed of approximately 250 mm (10 inches) per second and even double it with Beckhoff eXtreme Fast Control (XFC) technology. Bernd Esch: "With the XFC terminals and the matching sensors, we achieve speeds of up to 500 millimeters (20 inches) per second. Despite this enormous speed, the system detects the fiducials reliably and performs its calculations and closed-loop control operations accurately. XFC is also a very interesting feature for us because it can be used to let the moving products trigger the inspection cameras with exceptional accuracy."

Further Information:

www.rohrerag.com

www.beckhoff.ch



Error-free and time-saving:
The Eco-Dex machine automatically
deals with patient-specific medication
management.

Automated medication management in hospitals

Individual medication management for hospital patients is time-consuming and error-prone. To better protect patients, France adopted a new regulation in 2010 that obliges hospitals to administer drugs daily, in single doses, and identified with the patients' names. In order to make compliance as efficient and economical as possible, the company Eco-Dex developed a machine with Beckhoff control technology to help manage these requirements.

Eco-Dex was established by Loïc Bessin and Stéphane Ouvrard in response to the new regulation for individual medication management. With their combined expertise from 10 years experience in the design of packaging robots and the production of tools for the pharmaceutical industry, they went about developing an efficient and cost-effective solution that relieves nursing staff from the time-consuming task of medication management while eliminating errors.

Robots deal with individualized drug dosing

The standard model of the Eco-Dex machine consists of two feeding stations, each equipped with a Panel PC and a camera that reads bar codes and Data Matrix codes. The first station with a supply management database handles the drug supply, the second feeds the pill dispensers. "First the product is identified via the bar code on the drug packaging. The packing characteristics are transmitted to the robotic cell, which then executes suitable cuts for opening the



pack,” said Jérôme Cassin, project manager at Eco-Dex. The blister packs are then separated and packed in pouches that are labeled with the name of the drug, the expiration date, the batch number and a Data Matrix code. The second feeding station mimics the work of a pharmaceutical assistant processing prescriptions by distributing the individual drug doses in personally identified dispensers for each patient.

TwinCAT as the integrated control platform

TwinCAT NC PTP automation software from Beckhoff acts as the integrated control platform for PLC and Motion Control. In collaboration with Asprod, a systems integrator, Eco-Dex developed specific application software for controlling and monitoring orders and supplies, the interface with the hospital’s prescription program and preparation of goods receipt lists, etc. All machine processes are coordinated by a built-in CP6202 Panel PC, which controls the whole motion system including nine servomotors from the AM3000 series, AX5000 EtherCAT servo drives, linear motors, six cameras as well as 30 optical and inductive sensors. Eco-Dex uses EtherCAT as the communication system. “A big advantage of EtherCAT is the wide range of fieldbus interfaces, enabling integration of peripherals such as the robotic cell, and also the fact that EtherCAT is so widely used these days. This means we can easily integrate the linear motor from another manufacturer as an EtherCAT slave, for example,” said Jérôme Cassin.

The machine is modular, so that up to three cutting modules and two collection modules can be combined. The modules are standardized and can be customized to the specific requirements of the respective hospital via the software. Functionality can be extended with various software interfaces as required, to integrate pharmacy management, for example.

“Another advantage of the PC-based control platform is the possibility to rectify malfunctions very quickly (the time limit specified by hospitals is six hours) through remote diagnostics and access,” said Stéphane Ouvrard. In addition, new product data such as cutting methods, verification procedures, images, etc. can be provided via remote data transmission whenever new drugs are to be processed or when the packaging of existing drugs has changed.

Further Information:

www.eco-dex.fr

www.asprod.fr

www.beckhoff.fr



PC-based shrink film packaging machine for PET and glass bottles

High-precision film cutting control with TwinCAT

Chinese machine builder, Yinghui Packaging Mechanical Equipment, based in Foshan in Guangdong province, specializes in industrial equipment for packaging applications such as fully automatic shrink film wrappers, carton strappers, palletizers, carton loading and unloading systems and labelers. Yinghui uses integrated PC-based control technology from Beckhoff in order to meet the requirements of the international ISO9001 quality standard for its machines.

Clients of high-quality Yinghui packaging machines for beverage, food and chemical products include large Chinese companies such as the Yanjing and Tsingtao breweries and the Hainan Coconut Palm Group.

Shrink film packaging machine bundles bottles

The P series shrink film packaging machine is one of Yinghui's big sellers: The machine separates bottles and wraps them horizontally. Changeovers are quick and easy, and the machine is therefore suitable for processing a wide range of bottle types. A special film feeding and cutting machine ensures exact film lengths. The biaxial protector device facilitates film changes. To ensure a visually attractive finish, uniform film shrinking takes place in a carton feeding channel with a hot air device.

The control platform for the machinery consists of: a CX1010 Embedded PC, AX5000 series EtherCAT Servo Drives, AM8000 servomotors with One Cable Technology (OCT) and TwinCAT PTP automation software.

Precise I/Os in conjunction with high-performance sensors ensure perfect film cutting

High-performance sensors are used at critical points in shrink wrapping machines where the position of objects must be picked up quickly and precisely. For example, the film feed unit for the Yinghui shrink film packaging machine for 60 units reaches a speed of more than 2 m/s. This means that the film markings must be sampled at high speeds in order to ensure precise cuts.

The respective axis position is logged in real-time via the measuring probe functions of the AX5000 EtherCAT Servo Drives and is stored with a timestamp. In the drives, a relevant event may be the edge of an input signal for an optical high-speed switch, for example. The drives store the data for this position immediately, independent of the PLC cycle time. Activation of the measuring probe function requires configuration of the relevant parameters in the drives. To this end the measuring probe is linked with the function block MC_TouchProbe in TwinCAT and managed via this function. It determines when the measuring

Yinghui Packaging uses Beckhoff AM8000 servomotors. In conjunction with the camming function in TwinCAT automation software, the servomotors ensure jerk-free movement of the bottles.



The shrink film packaging system is operated via a built-in "Economy"-type Control Panel.



AX5000 series EtherCAT Servo Drives are used for exact positioning of the motors. The axis positions are sampled in real-time via the measuring probe functions of the AX5000 Servo Drives.

probe function is activated, or whether the trigger window must be set or not. The position of the film marker is precisely sampled by the measuring probe function. If a deviation is detected, the alignment is rectified in advance. The cut deviation is then adjusted in real-time, based on the online edit function of the NC CAM table. This ensures that the markings of all films are identical.

Jerk-free motion during bottle separation via TwinCAT Camming

The electronic gearing ensures appropriate transformation of the slave axis speed relative to the master axis. The cam plate is used to determine the relationship between slave and master axis positions. The TwinCAT motion control package offers a variety of motion functions, which can be edited and configured with the TwinCAT CAM Design Editor. The TwinCAT NC Camming library is used to execute the motion functions and modify them online. In this way, it is possible to not only specify the position of a slave axis relative to a master axis, but also the motion function between two adjacent points, so that sections for "smooth speed" or "smooth acceleration" can be defined.

High-precision bottle separation, which is the key and most difficult part of the whole machine, takes place via the TwinCAT cam plate function and is jerk-free thanks to the flexible cam plate algorithm. A beneficial side effect is enhanced service life of the motors. If different clamping jaws are used, the bottle separation system can offer different offsets via online modification of the cam plate function. Therefore, it is possible to correct deviations relating to the mechanical configuration in order to make bottle separation more stable and precise. The system (with offset function) can stabilize the process significantly, particularly for smaller or squared bottles. If the motors for bottle separation and the spindle motor are coupled, the speed of the bottle separation motor can be adjusted automatically to different operating speeds of the whole machine.

Further Information:

www.china-yh.net

www.beckhoff.com.cn

References

PC- and EtherCAT-based control technology from Beckhoff is in use in packaging machines worldwide. Below please find a choice of customer references showing the wide range of possible applications. The QR codes link to the respective application report on www.pc-control.net.



Baader-Johnson: Industrial processing and packaging of poultry, fish and meats



Further Information:
www.baader.com



ITEC: Automatic systems that cut, print, unclip, sort or convey sausage products



Further Information:
www.itec.de



VMS Maschinenbau:
Filling machine for polishing paste



Further Information:
www.vms-maschinenbau.de

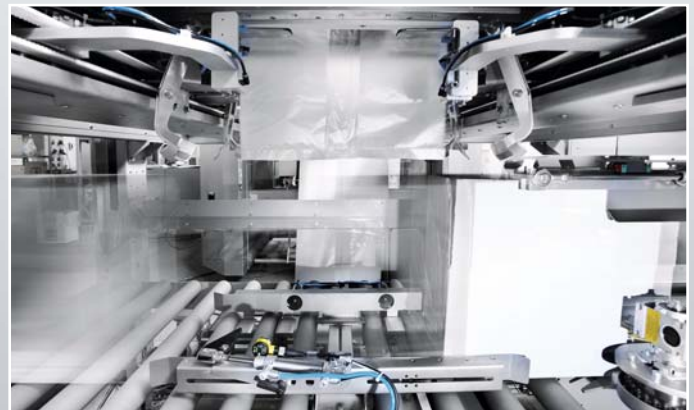

Pattyn Packing Lines:
Bag-in-box foodstuff packaging



Further Information:
www.pattyn.com



KOCH Pac-Systeme: High-end solution for blister packaging



Further Information:
www.koch-pac-systeme.com



Paktech: Handle applicator for applying plastic handles on bundles of PET bottles and plastic containers



Further Information:
www.paktech-opi.com



Velteko: Vertical hose packaging machine for packaging viscous, liquid or solid goods



Further Information:
www.velteko.com

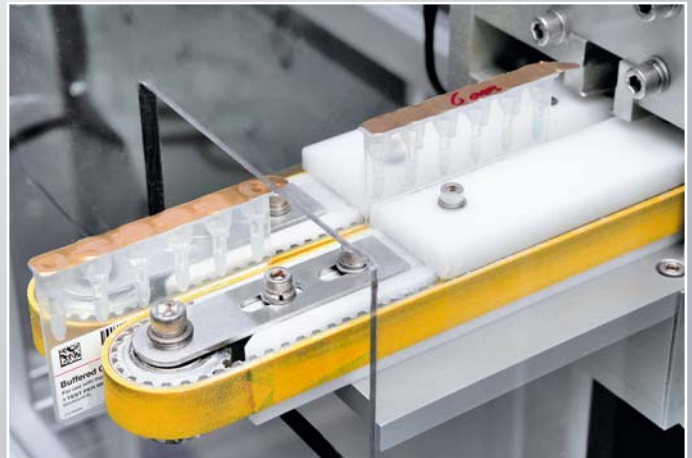

Wierciszewski Controls: Packaging and visual inspection of blood testing products



Further Information:
www.wcontrols.embarqspace.com



www.beckhoff.com/packaging

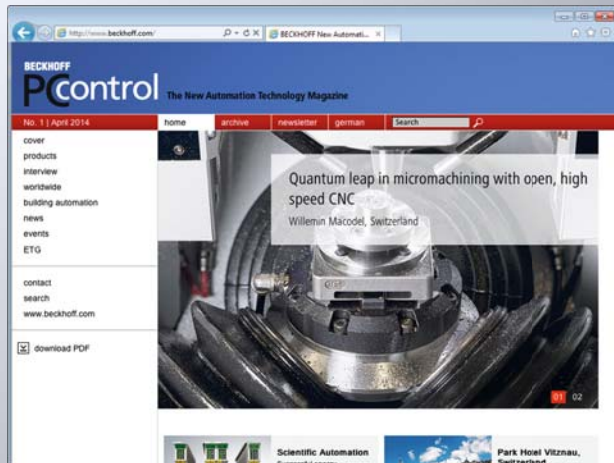

www.pc-control.net

