



Two-Stage Snow Blower

Operator's Manual

MODEL NUMBER

YB5765

SERIAL NUMBER

PURCHASE DATE

Both model number and serial number may be found on the main label. You should record both of them in a safe place for future use.

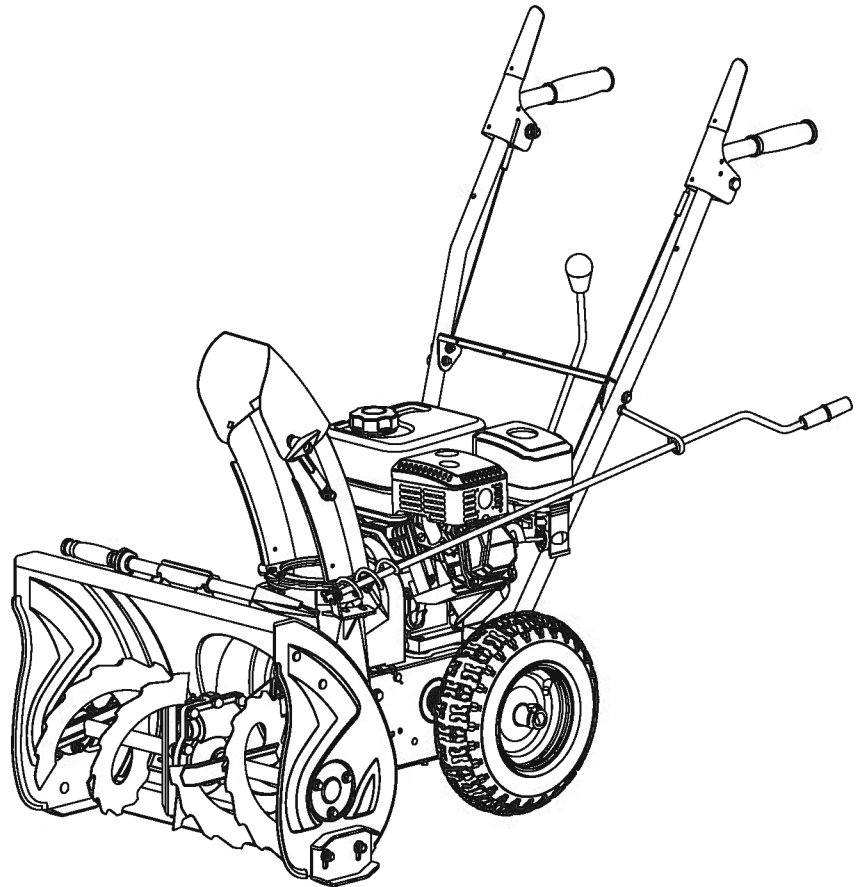

FOR YOUR SAFETY

READ AND UNDERSTAND THE ENTIRE MANUAL BEFORE OPERATING MACHINE

Your new YARDMAX® snow blower offers quality construction, and is easy and safe to operate. With proper use and care, it is designed to give you many years of dependable service.

Prepare to experience the durability to take on any job with the ease, portability, and convenience of your new snow blower!

Discover the YARDMAX Advantage

At YARDMAX, we understand that land ownership definitely has its privileges, but it also comes with a great deal of responsibility. When duty calls and you need to respond, will you have what it takes to tame the great outdoors?

When looking for outdoor power equipment (OPE) to get the job done right, at the right price, YARDMAX delivers the perfect combination of performance and practicality. YARDMAX has a solution that’s right for you.

MAX Performance, MAX Value, MAX Support – that’s YARDMAX

- ✓ Backed by decades of proven manufacturing expertise
- ✓ Enhanced design features come standard
- ✓ Engineered for the best user experience
- ✓ Quality metal parts are used instead of plastic
- ✓ A robust warranty supports all products
- ✓ Budget-friendly prices make it practical



Up for the job? YARDMAX is.

TABLE OF CONTENTS

Introduction	1
Specifications	3
Symbols	4
Safety	4
Contents Supplied	7
Assembly	8
Know Your Machine	13
Adjustment	16

Operation	18
Maintenance	20
Service	21
Storage	24
Troubleshooting	25
Parts Diagram	27
Parts List	29



Carefully read through this entire operator's manual before using your new unit. Pay attention to all cautions and warnings.

This unit is a gasoline engine driven snow blower. It is perfect for tackling medium snowfall – easily able to cut through snow in excess of a foot or more. It is easy and safe to operate. With proper use and care, it should give you many years of dependable service.

ENGINE MANUAL

Please refer to the **Engine Manufacturer's** owner/operator's manual, packed separately with your unit, for more information.

EMISSION CONTROL SYSTEM

This equipment or its engine may include exhaust and evaporative emission control system components required to meet U.S. Environmental Protection Agency (EPA) and/or California Air Resources Board (CARB) regulations. Tampering with emission controls and components by unauthorized personnel may result in severe fines or penalties. Emission controls and components can only be adjusted by an authorized engine manufacturer's service center.

CALIFORNIA PROPOSITION 65 WARNING

Engine exhaust, some of its constituents and certain product components contain or emit chemicals known to the state of California to cause cancer and birth defects or other reproductive harm. For more information, go to www.P65Warnings.ca.gov.

ENVIRONMENTAL



Recycle unwanted materials instead of disposing of them as waste. All tools, hoses, and packaging should be taken to the local recycling center and disposed of in an environmentally safe way.

MODEL AND SERIAL NUMBERS

Record the model and serial number as well as date and place of purchase for future reference. Have this information available when ordering parts, optional accessories and when making technical or warranty inquiries.

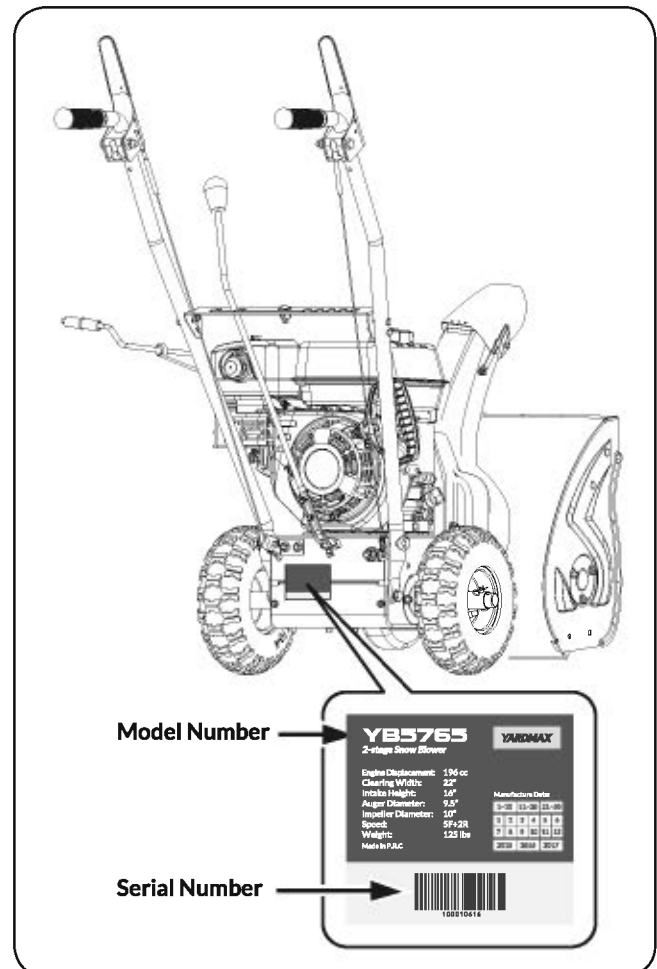

DISCLAIMER

YARDMAX reserves the right to discontinue, change, and improve its products at any time without notice or obligation to the purchaser. The descriptions and specifications contained in this manual were in effect at printing. Equipment described within this manual may be optional. Some illustrations may not be applicable to your unit.

SUPPORT

Have questions about your YARDMAX equipment? Call us at 847-327-0566 or 844-YARDMAX, email us at support@yardmax.com, or contact us via your favorite social media site.

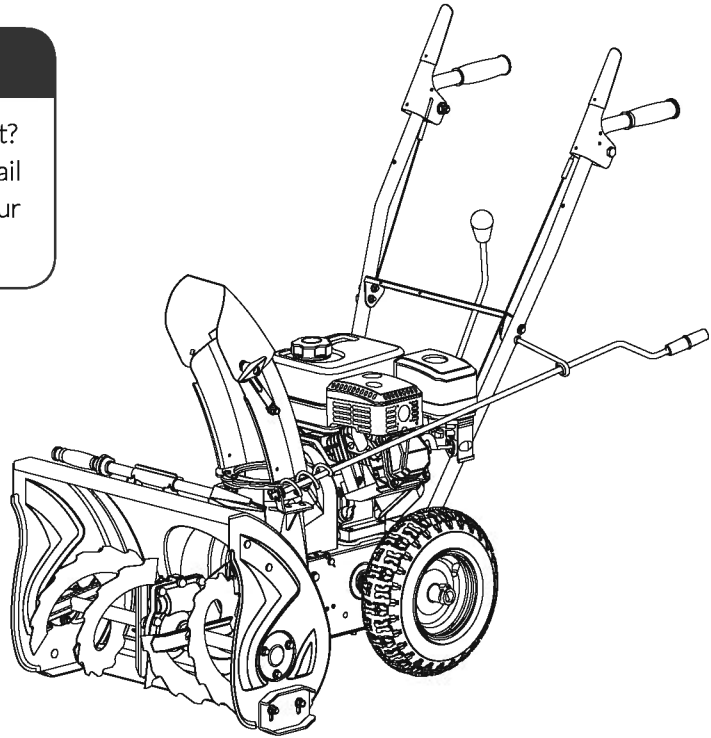



SPECIFICATIONS

Model Number	YB5765
Clearing Width	22"
Engine	YARDMAX
Displacement	196 cc
Start Type	Recoil
Auger Diameter	9.5"
Impeller Diameter	10"
Chute Control	Crank
Chute Type	Steel
Intake Depth	16"
Tires	13" x 4"
Forward Speeds	5
Reverse Speeds	2
Product Weight	127 lbs

SYMBOLS

The rating plate on your machine may show symbols. These represent important information about the product or instructions on its use.

	Read these instructions carefully.		No smoking, sparks, or flames.
	Wear eye protection.		Do not touch parts which are hot from operation. Serious burns may result.
	Wear safety footwear.		Stop engine, remove key, read manual before making any repairs or adjustments.
	Keep children and bystanders off and away.		Keep hands out of the inlet and discharge openings while machine is running.
	Stop engine and remove ignition key prior to leaving the operator's position.		Stay away from rotating augers.
	Only use clean-out tool to clear blockage. Never use your hands.		Never direct discharge towards persons or property.
	Do not remove or tamper with the protection and safety devices.		

SAFETY

GENERAL SAFETY RULES

UNDERSTAND YOUR MACHINE

Read this manual and labels affixed to the machine to understand its limitations and potential hazards.

Be thoroughly familiar with the controls and their proper operation. Know how to stop the machine and disengage the controls quickly.

Make sure to read and understand all the instructions and safety precautions as outlined in the **Engine Manufacturer's** manual packed separately with your unit. Do not attempt to operate the machine until you fully understand how to properly operate and

maintain the engine and how to avoid accidental injuries and/or property damage.

If the unit is to be used by someone other than original purchaser or loaned, rented, or sold, always provide this manual and any needed safety training before operation. The user can prevent and is responsible for accidents or injuries that may occur to themselves, other people, and property.

Do not force the machine. Use the correct machine for your application. The correct machine will do the job more efficiently and safer at the rate it was designed.

PERSONAL SAFETY

Do not permit children to operate this machine at any time.

Keep children, pets, and other people not using the unit away from the work area. Be alert and shut off unit if anyone enters work area. Keep children under the watchful care of a responsible adult.

Do not operate the machine while under the influence of drugs, alcohol, or any medication that could affect your ability to use it properly.

Dress properly. Wear heavy long pants, boots, and gloves. Do not wear loose clothing, short pants, or jewelry of any kind. Secure long hair so it is above shoulder level. Keep your hair, clothing, and gloves away from moving parts. Loose clothes, jewelry, or long hair can be caught in moving parts.

Protect eyes, face, and head from objects that may be thrown from the unit. Always wear safety goggles or safety glasses with side shields when operating.

Wear appropriate hearing protection.

Always keep hands and feet away from all moving parts during operation. Moving parts can cut or crush body parts.

Always keep hands and feet away from all pinch points.

Do not touch parts that might be hot from operation. Allow parts to cool before attempting to maintain, adjust, or service.

Stay alert, watch what you are doing, and use common sense when operating the machine.

Do not overreach. Do not operate the machine while barefoot or when wearing sandals or similar lightweight footwear. Wear protective footwear that will protect your feet and improve your footing on slippery surfaces. Keep proper footing and balance at all times. This enables better control of the machine in unexpected situations.

INSPECT YOUR MACHINE

Check your machine before starting it. Keep guards in place and in working order. Make sure all nuts, bolts, etc., are securely tightened.

Never operate the machine when it is in need of repair or is in poor mechanical condition. Replace damaged, missing, or failed parts before using it. Check for fuel leaks. Keep the machine in safe working condition.

Do not use the machine if the engine's switch does not turn it on or off. Any gasoline powered machine that can't be controlled with the engine switch is dangerous and must be replaced.

Regularly check to see that keys and adjusting wrenches are removed from the machine area before starting it. A wrench or a key that is left attached to a rotating part of the machine may result in personal injury.

Avoid accidental starting. Be sure the engine's switch is off before transporting the machine or performing any maintenance or service on the unit. Transporting or performing maintenance or service on a machine with its switch on invites accidents.

If the machine should start to vibrate abnormally, stop the engine (motor) and check immediately for the cause. Vibration is generally a warning sign of trouble.

ENGINE SAFETY

This machine is equipped with an internal combustion engine. Do not use on or near any unimproved, forest covered, or brush covered land unless the exhaust system is equipped with a spark arrester meeting applicable local, state, or federal laws.

In the state of California, a spark arrester is required by law. Other states have similar laws. A spark arrester, if used, must be maintained in effective working order by the operator.

Never start or run the engine inside a closed area. The exhaust fumes are dangerous, containing carbon monoxide, an odorless and deadly gas. Operate this unit only in a well-ventilated outdoor area.

Do not tamper with the engine to run it at excessive speeds. The maximum engine speed is preset by the manufacturer and is within safety limits. See engine manual.

Keep a Class B fire extinguisher on hand when operating this snow blower in dry areas as a precautionary measure.

FUEL SAFETY

Fuel is highly flammable, and its vapors can explode if ignited. Take precautions when using to reduce the chance of serious personal injury.

When refilling or draining the fuel tank, use an approved fuel storage container while in a clean, well-ventilated outdoor area. Do not smoke, or allow sparks, open flames, or other sources of ignition near the area while adding fuel or operating the unit. Never fill the fuel tank indoors.

Keep grounded conductive objects, such as tools, away from exposed, live electrical parts and connections to avoid sparking or arcing. These events could ignite fumes or vapors.

Always stop the engine and allow it to cool before filling the fuel tank. Never remove the cap of the fuel tank or add fuel while the engine is running or when the engine is hot. Do not operate the machine with known leaks in the fuel system.

Loosen the fuel tank cap slowly to relieve any pressure in the tank.

Never overfill the fuel tank. Fill the tank to no more than 1/2" below the bottom of the filler neck to provide space for expansion as the heat of the engine can cause fuel to expand.

Replace all fuel tank and container caps securely and wipe up spilled fuel. Never operate the unit without the fuel cap securely in place.

Avoid creating a source of ignition for spilled fuel. If fuel is spilled, do not attempt to start the engine but move the machine away from the area of spillage and avoid creating any source of ignition until fuel vapors have dissipated.

When fuel is spilled on yourself or your clothes, wash your skin and change clothes immediately.

Store fuel in containers specifically designed and approved for this purpose.

Store fuel in a cool, well-ventilated area, safely away from sparks, open flames, or other sources of ignition.

Never store fuel or a machine with fuel in the tank inside a building where fumes may reach a spark, open flame, or any other source of ignition, such as a water heater, furnace, or clothes dryer. Allow the engine to cool before storing in any enclosure.

SPECIFIC SAFETY RULES

Do not operate without wearing adequate winter outer garments.

Do not use the machine on a roof.

Do not run the engine indoors, except when starting the engine and for transporting the snow thrower in or out of the building. Open the outside doors; exhaust fumes are dangerous.

Always check overhead and side clearances carefully before operation. Always be aware of traffic when operating along streets or curbs.

Thoroughly inspect the area to be worked. Keep the working area clean and free of toys, doormats, newspapers, sleds, boards, wires and other foreign objects, which could be tripped over or thrown by the auger/impeller. Check for weak spots on docks, ramps or floors.

Plan your snow-throwing pattern to avoid discharge toward people or areas where property damage can occur.

Do not operate near drop-offs, ditches, or embankments. Machine can suddenly turn over if a wheel is over the edge of a cliff or ditch, or if an edge caves in.

Keep all bystanders, children, and pets at least 75 feet (23m) away. If you are approached, stop the unit immediately.

Use a grounded three-wire extension cord and receptacle for all machines with electric start engines.

Check clutch and brake operation frequently. Adjust and service as required. All motion of drive wheels and auger/impeller must stop quickly when control levers are released.

Let engine and machine adjust to outdoor temperature before starting to clear snow.

Stay alert for hidden hazards or traffic.

Do not overload machine capacity by attempting to clear snow at too fast of a rate.

Do not throw snow any higher than necessary.

Adjust auger housing height to clear gravel or crushed rock surfaces. Exercise extreme caution when operating.

Exercise caution to avoid slipping or falling, especially when operating in reverse. Never operate machine at high transport speeds on slippery surfaces. Always look down and behind before and while backing.

Do not operate on steep slopes. Do not clear snow across the face of slopes. Keep all movement on slopes slow and gradual. Do not make sudden changes in speed or direction. Use a slow speed to avoid stops or shifts on slopes. Avoid starting or stopping on a slope. Do not park machine on a slope unless absolutely necessary. When parking on a slope, always block the wheels.

Disengage power to the auger/impeller when transporting or not in use.

Disengage all control levers and stop engine before you leave the operating position (behind the handles). Wait until the auger/impeller comes to a complete stop before unclogging the chute assembly, making any adjustments, or inspections.

Hand contact with the rotating impeller inside the discharge chute is the most common cause of injury associated with snow throwers. Do not unclog chute assembly while engine is running. Shut off engine and remain behind handles until all moving parts have stopped before unclogging. Never put your hand in the discharge or collector openings. Always use the clean-out tool provided to unclog the discharge opening.

CONTENTS SUPPLIED

Your YARDMAX snow blower comes partially assembled and contains the following:

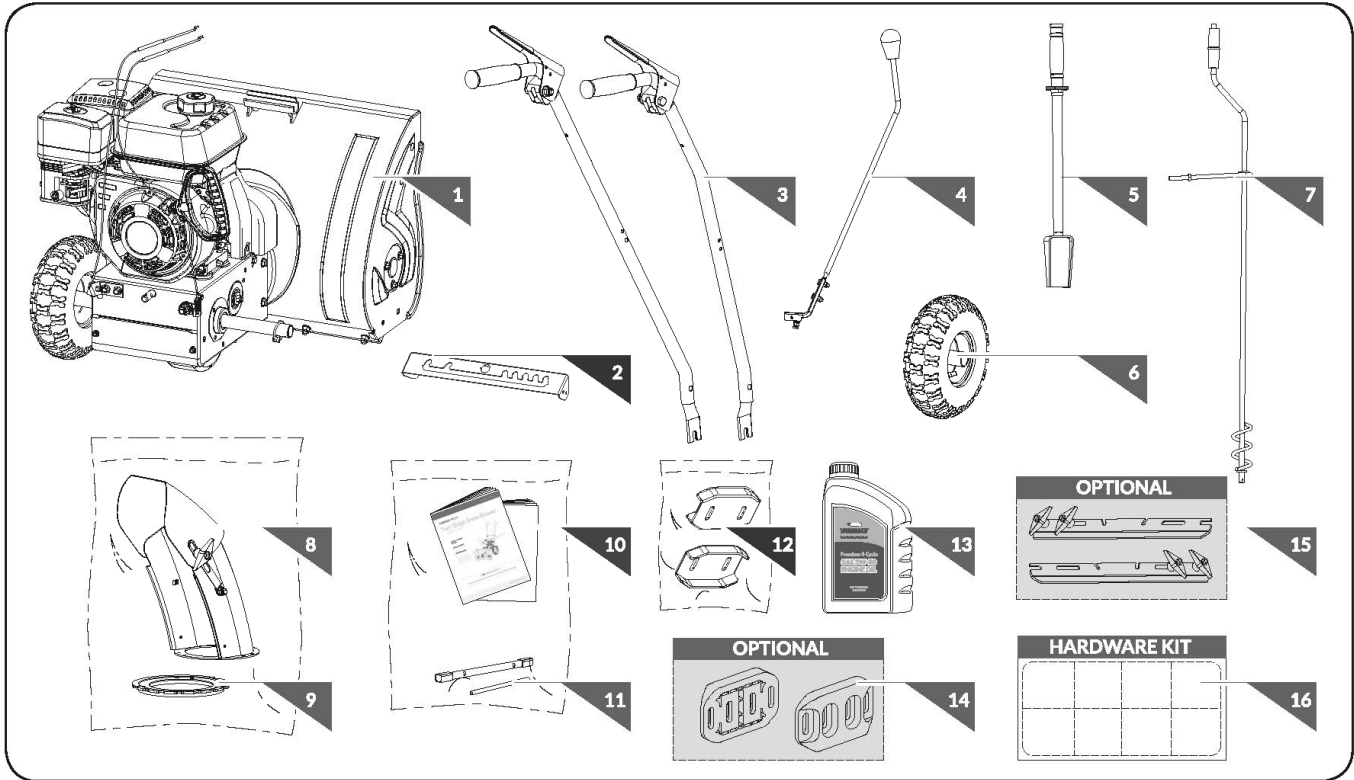

1. Main Machine
2. Control Panel
3. Handlebars
4. Shift Lever
5. Chute Clean-Out Tool
6. Wheel
7. Directional Chute Control
8. Discharge Chute
9. Chute Crank Flange
10. Operator's Manual & Engine Manual
11. Tools for Spark Plug Assembly
12. Skid Shoes
13. Engine Oil
14. Plastic Skid Shoes (Optional)
15. Drift Cutters (Optional)
16. Hardware Kit, Including

	M6 X 40	X 3	2
	M6 X 30	X 1	3
	M6 X 30	X 6	4
		X 3	4
	M8	X 1	5
		X 1	5
	M8 X 25	X 2	6
	M8 X 20	X 2	6

	M10 X 40	X 2	1
--	----------	-----	----------

REPLACEMENT PARTS			
		X 2	7
		X 2	
	6 X 37	X 2	8

ASSEMBLY

This snow blower was partially assembled at the factory. To assemble your machine follow the below instructions.

ENGINE AIR FILTER COVER

1. Remove wing nut from the air filter cover.
2. Rotate the air filter cover by 180° so that the primer faces outside.
3. Install air filter cover and tighten wing nut. (See **Figure 1**)



The engine is not equipped with an air filter. **DO NOT** use this engine for anything other than snow removal.

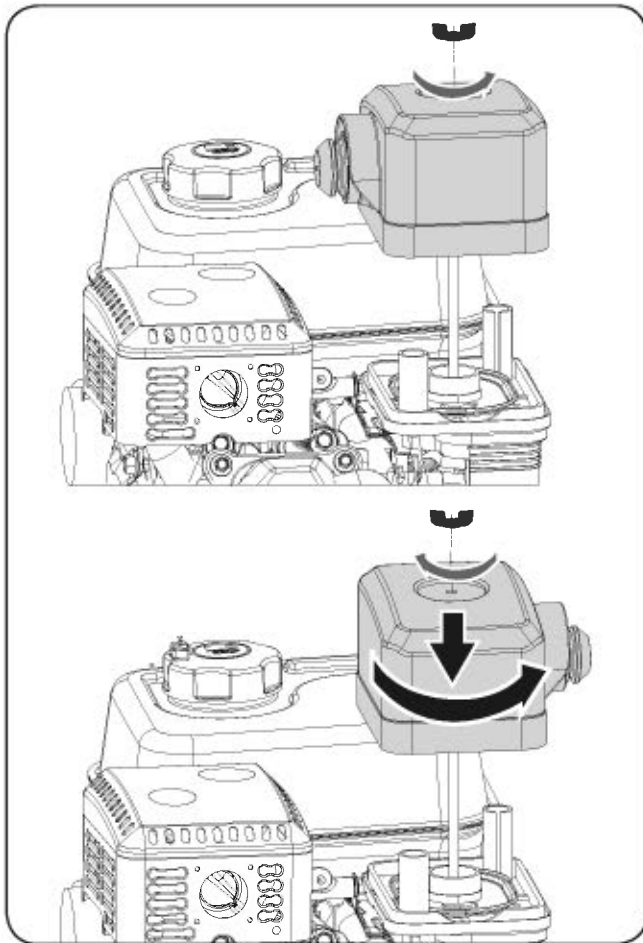

Figure 1

HANDLEBARS

1. Remove the axle pin from the axle. (See **Figure 2a**)
2. Remove the wheel from the axle.
3. Loosen the two bolts on the sides of the transmission housing.
4. Slide the handlebar slots in-between the transmission housing

YB5765PM01 - 1612

and the washer. Finger tighten the bolts to hold the handle in place. The handle with the chute crank sticker should be installed on the left side.

5. Align the holes in the handlebars with the upper holes on both sides of the transmission housing. Insert the bolts and curved washers and finger tighten to hold in place. (See **Figure 2b**)
6. Ensure the handlebars are at the same height, then tighten all four bolts from the previous steps.

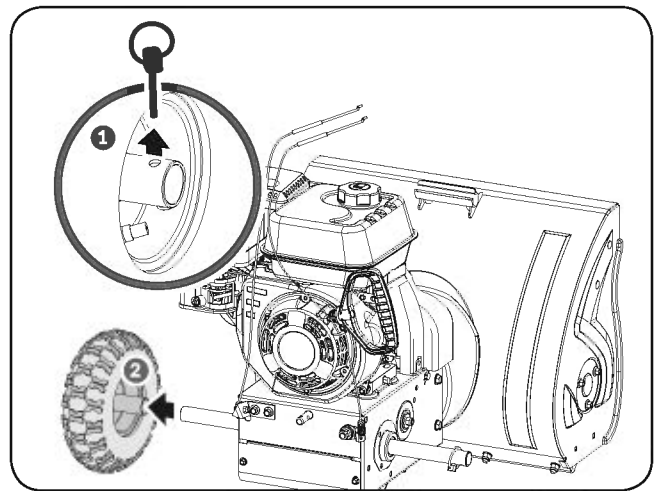

Figure 2a

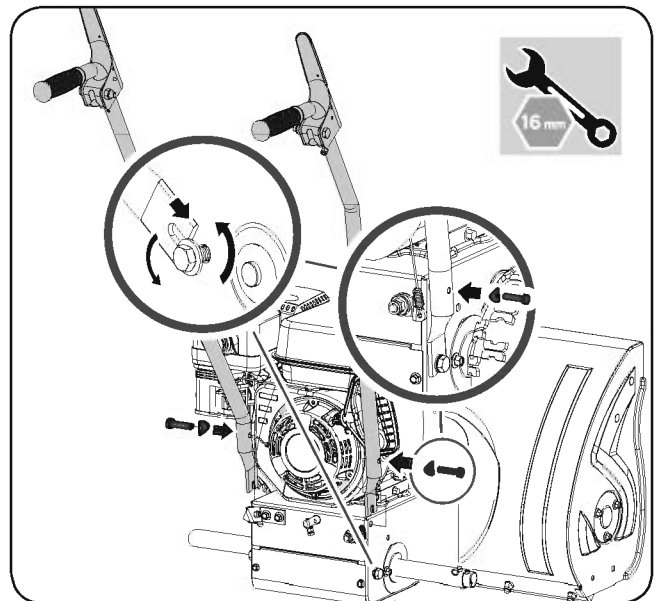

Figure 2b



M10 X 40

X2



Assembly |

WHEELS

1. Remove the axle pin from the axle.
2. Slide the wheel on the axle.
3. Insert the axle pin through the hole in the wheel hub and through the inside hole in the axle. When inserting the pin into the wheel, place the hole side of the pin block towards the outside for easier installation.

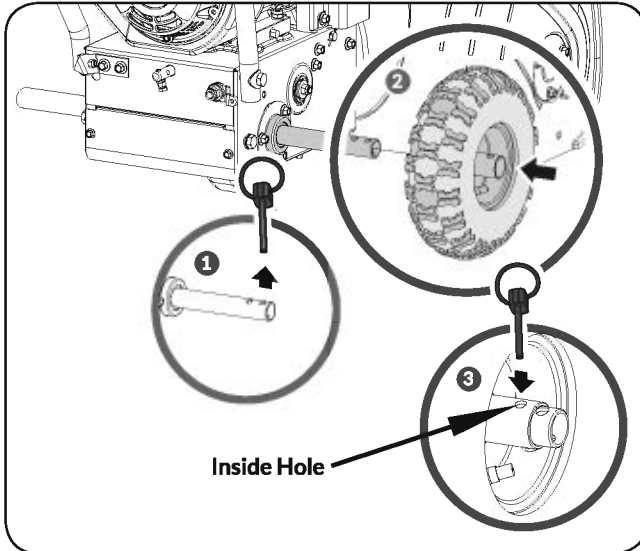

Figure 3

4. Follow the steps 1-3 to assemble the other wheel.

CONTROL PANEL

1. Place the control panel between the handle bars. Slide the three bolts and washers through the two holes on the right side of the handlebar and the left upper hole. Secure them by finger tightening the nuts. Leave the lower hole on the left hand side without a bolt. This will be used to secure the directional chute control assembly later. (See **Figure 4**).

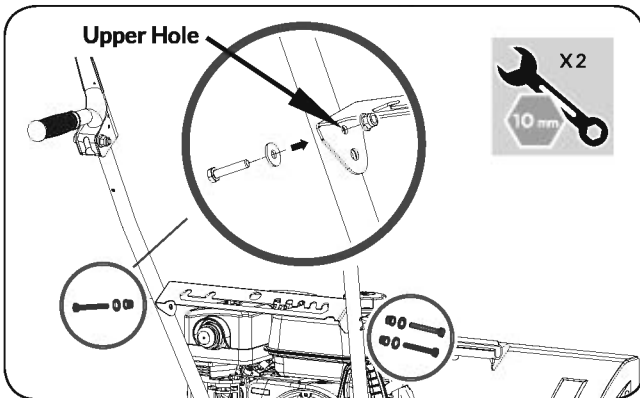

Figure 4

2. Once control panel is installed. Securely tighten lower handle and control panel bolts.

SPEED SHIFT LINKAGE

1. Remove the knob to slide the shift lever through the slot in the control panel.
2. The adjusting bolt will need to be loosen to install shift arm (See **Figure 5a #2**). Secure shift lever to the shift arm with screw and nut.
3. Reattach the knob.

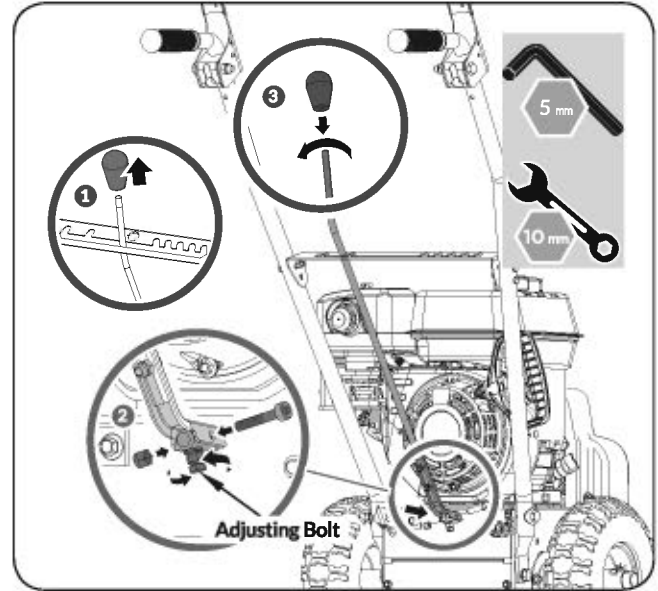

Figure 5a



4. Slowly tighten the adjusting bolt until the shift lever has tension with a spring action when shifting from Neutral to a Drive Gear position.

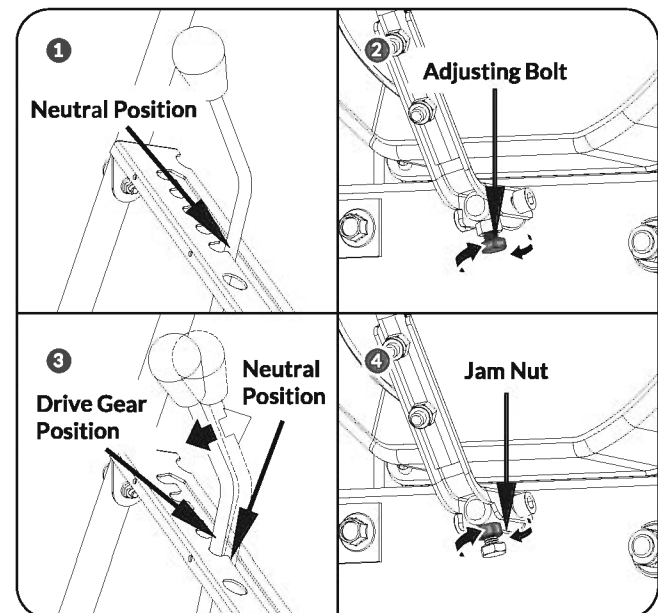

Figure 5b

CONTROL CABLES

Disconnect the Z-fittings from the turnbuckles and hook them into the lower holes in the clutch levers. Thread the turnbuckles without turning the cables onto Z-fittings until there is no slack in the cables. Do not overtighten the cables. Hold the flats on the turnbuckles with pliers and tighten the jam nuts against the turnbuckles. (See **Figure 6b**)

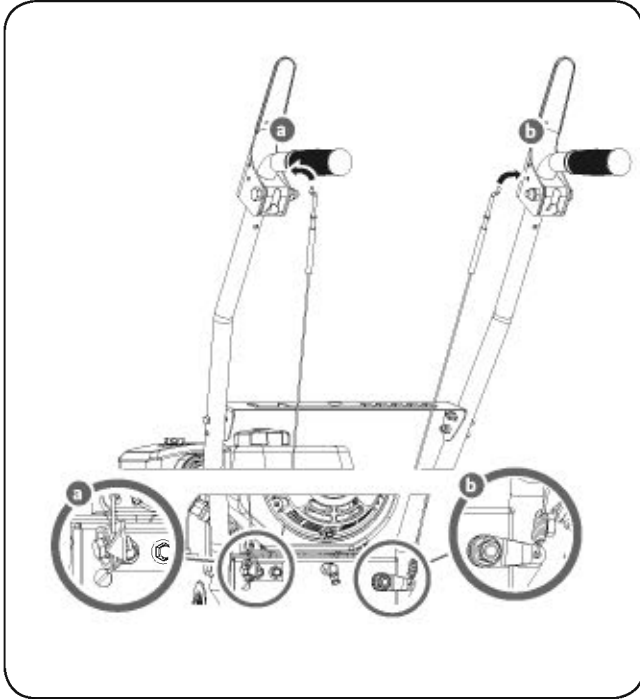

Figure 6a

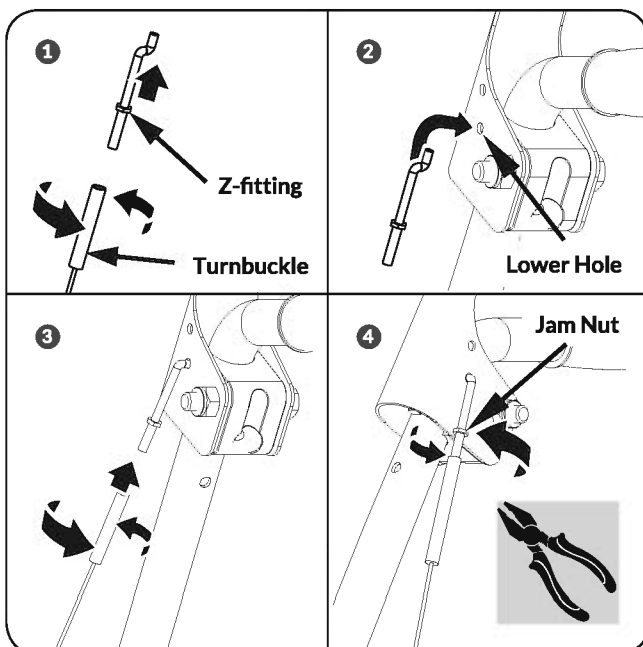

Figure 6b

CHUTE CLEAN-OUT TOOL

Fasten the clean-out tool to the mounting clip on the rear of the auger housing. (See **Figure 7**)

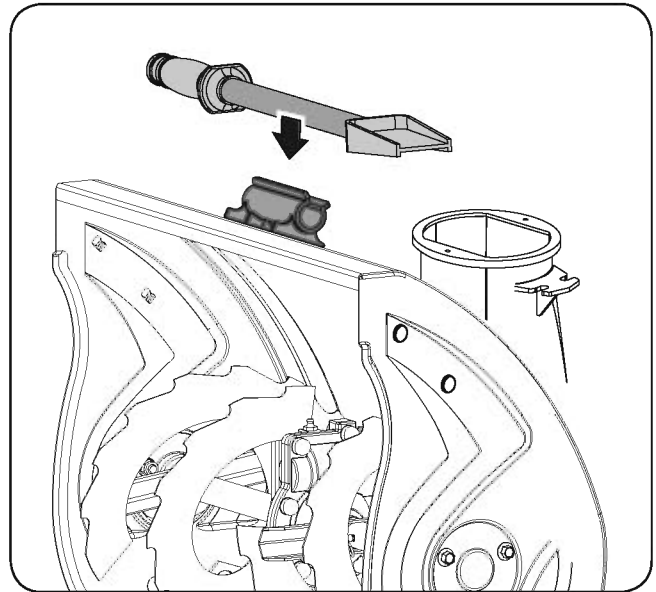

Figure 7

DISCHARGE CHUTE

1. Sit the chute crank flange on top of the impeller housing. Make sure the notched edge is on the left side and the pre-greased surface is on the bottom. (See **Figure 8a**)

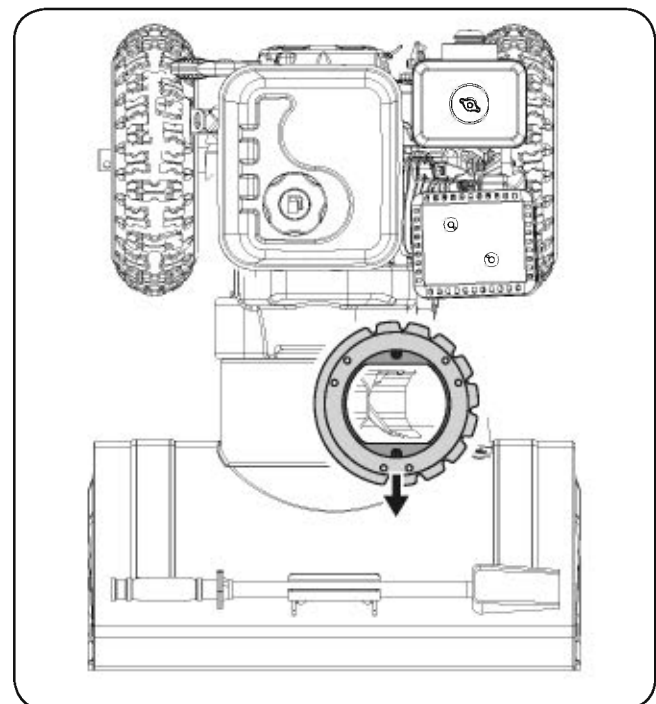

Figure 8a

- Place the discharge chute facing it forward over the chute crank flange. (See **Figure 8b**)

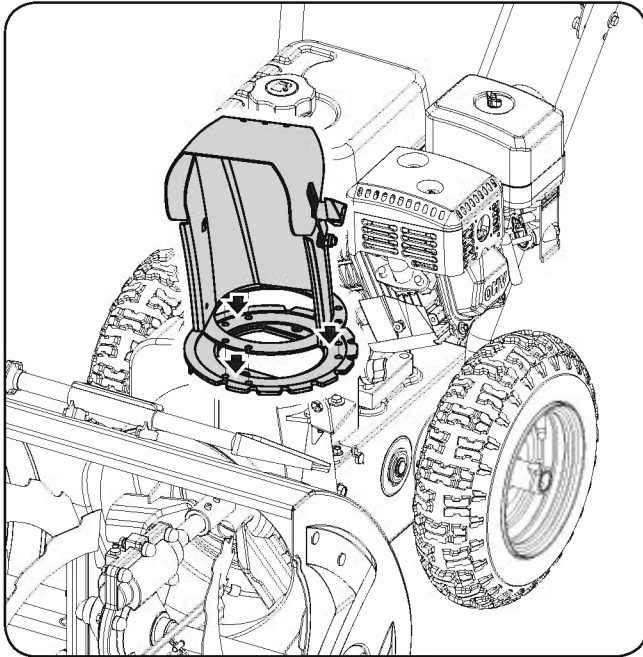

Figure 8b

- Secure the three flange keepers to the bottom of the chute crank flange by sliding the bolts through the chute base holes, sliding the keepers up from the bottom, then securing them with the included nuts. (See **Figure 8c**)

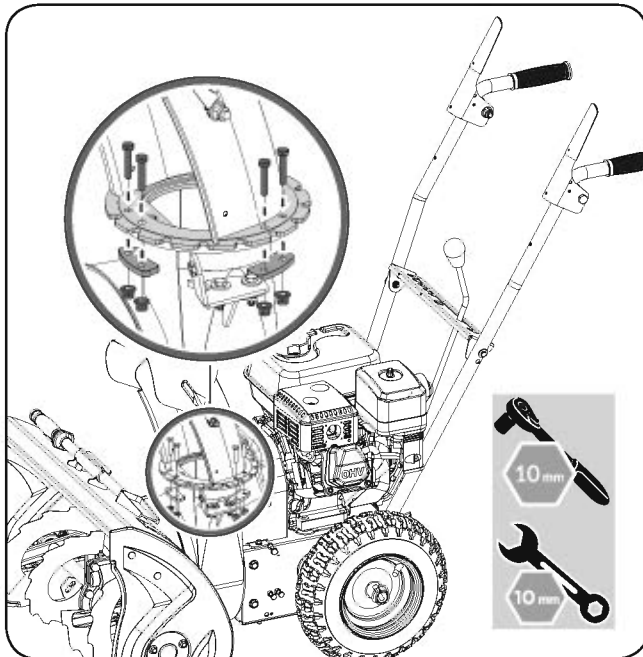

Figure 8c

	M6 X 30	X6	4
		X3	

DIRECTIONAL CHUTE CONTROL

- Slide the spiral end of the directional chute control lever into the chute bracket.
- Attach the directional chute control lever to the handlebar through the upper holes on the left handle by sliding the bolt thru the hole. Use the curved washer and nut to secure it to the handlebar. Leave it finger tight for easier alignment later.
- Secure the spiral end on the chute bracket by sliding on the flat washer and clevis pin. (See **Figure 9a**)

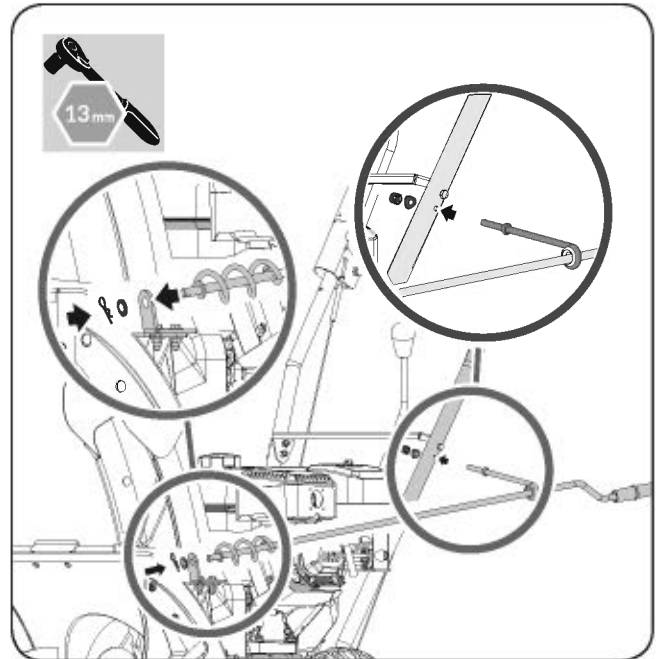

Figure 9a

	M8	X1	5
		X1	

- Make sure the spiral at the bottom is fully engaging with the chute crank flange and tighten the two bolts on the chute bracket. (See **Figure 9b**)

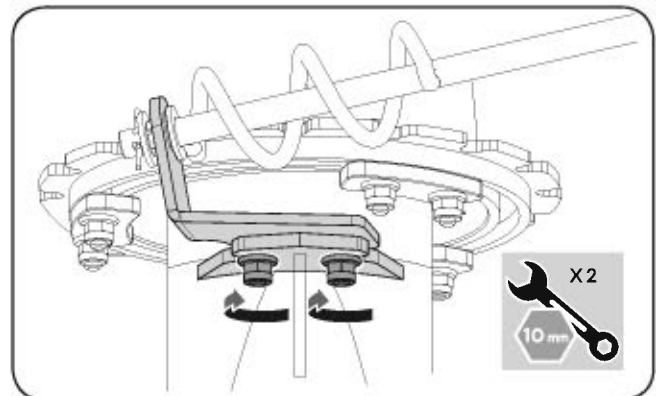

Figure 9b

- Tighten the nut which secures the directional chute control on the handlebar.

SKID SHOES

1. Place the machine is on a level and solid surface.
2. Lift the machine so that the scraper blade is 1/8" (3mm) above the ground, ensuring it is level. A piece of cardboard half the thickness of the snow blower packaging placed under the scraper blade is recommended.
3. Attach the skid shoes to the sides of auger housing with the bolts and nuts. The shorter M8X20 bolts should be in the front holes while the longer M8X25 bolts in the rear holes. Move the skid shoes down as far as possible. Be sure both skid shoes are adjusted evenly. Tighten securely. (See **Figure 10**)

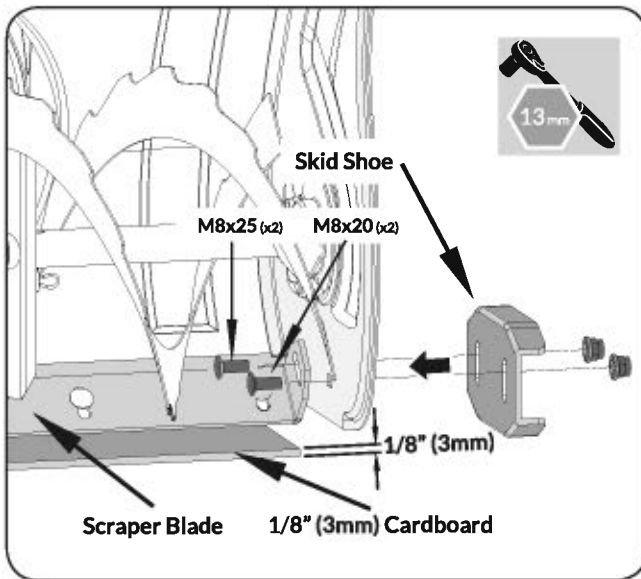

Figure 10

	M8 X 25	X 2	6
	M8 X 20	X 2	

4. Remove the 1/8" (3mm) spacer you used from under the scraper blade.

TIRES

The tires are over-inflated at factory for shipping purposes. Check the pressure in the tires prior to usage. Reduce or increase air pressure to ensure equal tire pressure to the manufacturer's recommended pressure. The recommended air pressure can be found on the tire sidewall.



Under any circumstance do not exceed manufacturer's recommended pressure. Excessive pressure when seating beads may cause tire/rim assembly to burst with force sufficient to cause serious injury. Refer to side wall of tire for recommended pressure.



Equal tire pressure should be maintained at all times. If the tire pressure is not equal in both tires, the machine may not travel in a straight path and the scraper blade may wear unevenly.



Keep tires free of gasoline and oil, which can harm rubber.

KNOW YOUR MACHINE

FEATURES AND CONTROLS

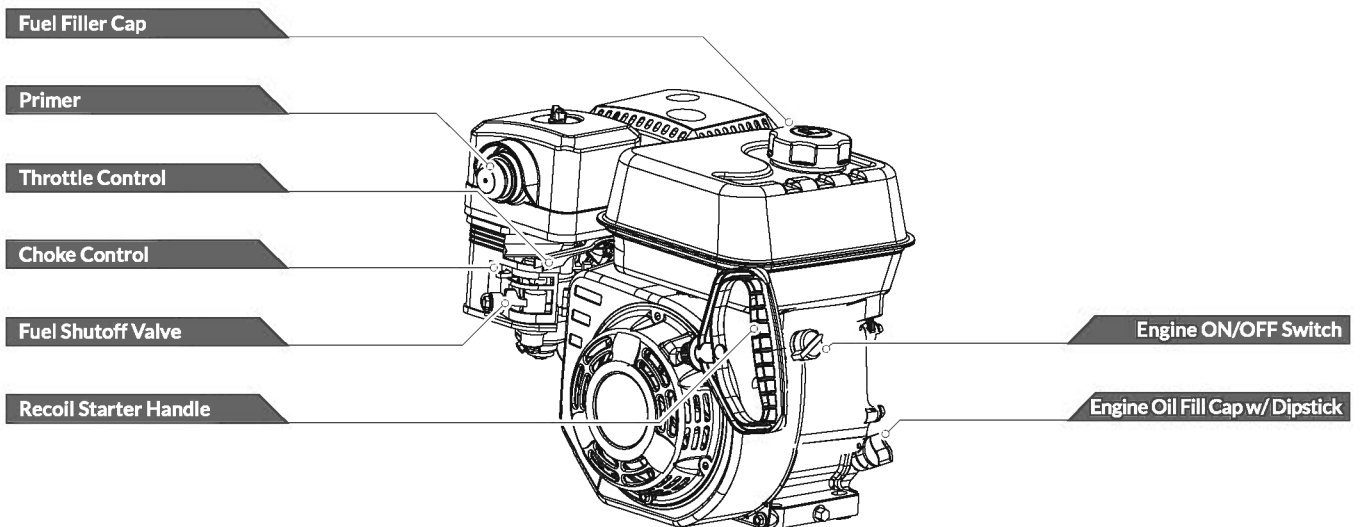
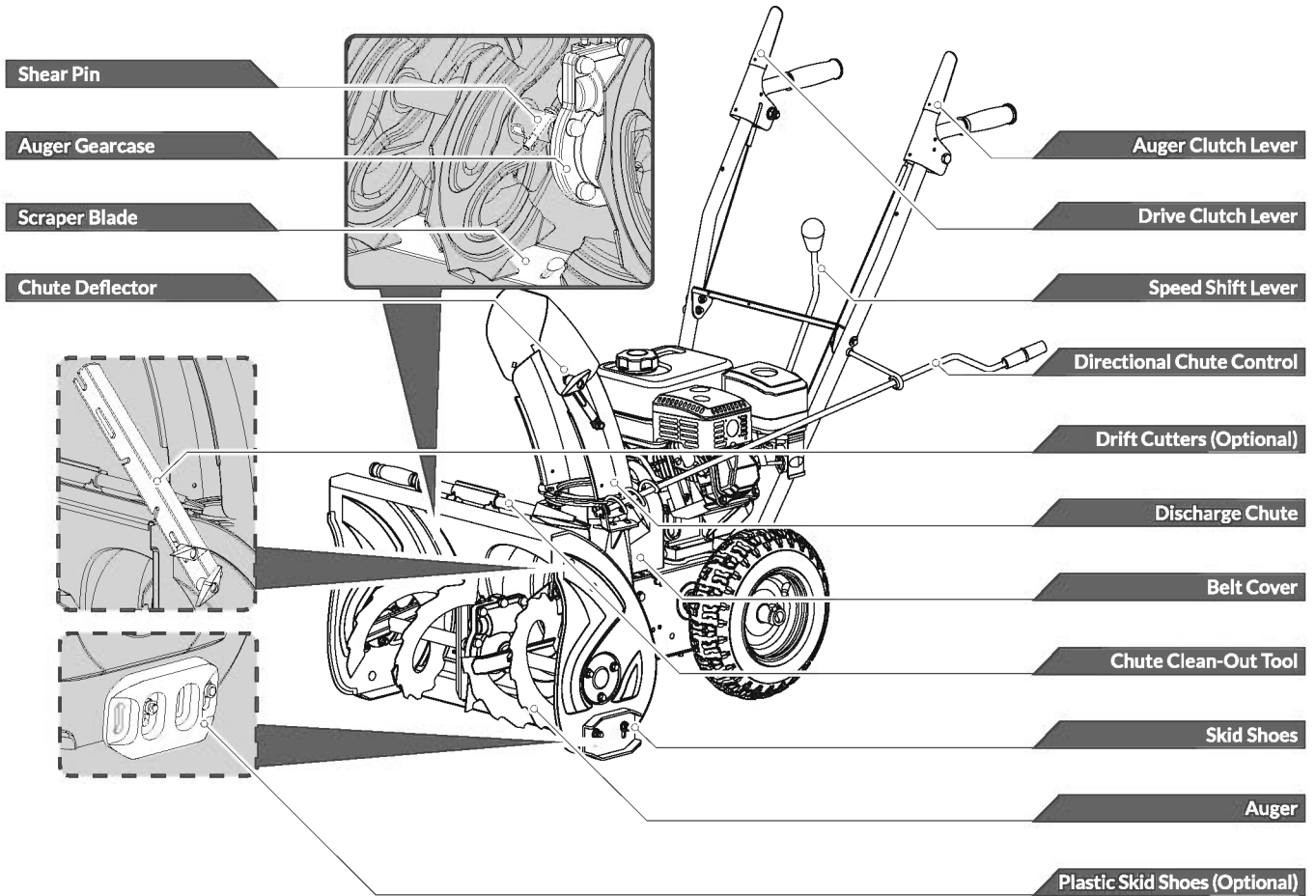

SPEED SHIFT LEVER

- » The speed shift lever has 7 positions: 5 forward speeds and 2 reverse. To change speeds, move the speed shift lever to the desired position. The lever locks in a notch at each speed selection.



 *Always release the drive clutch lever before changing speeds. Failure to do so will result in damage to the snow blower.*

- » Slower speeds are for heavier snow and faster speeds are for light snow and transporting the snow blower.
- » It is recommended that you use a slower speed until you are familiar with the operation of the snow blower.
- » If the engine slows down under a load or the wheels slip, shift the machine into a lower gear.
- » If the front of the machine rides up, shift the machine into a lower gear. If the front continues to ride up, lift up on the handles.

DIRECTIONAL CHUTE CONTROL

- » Rotate the directional chute control clockwise to move the discharge chute to the left; counterclockwise to move the chute to the right.



CHUTE DEFLECTOR

- » Move the deflector handle forward to move the snow stream down; move it rearward to move the snow stream up.

DRIVE CLUTCH LEVER

- » Squeeze the clutch lever against the handgrip to engage the wheel drive. Release to disengage.



 *Always release the drive clutch lever before changing speeds. Failure to do so will result in damage to the snow blower.*

AUGER CLUTCH LEVER

- » Squeeze the clutch lever against the handgrip to engage the auger and start snow throwing action. Release to disengage.



SCRAPER BLADE & SKID SHOES

- » The scraper blade allows better contact with the surface being cleared. It also prevents damage to the housing from normal use.
- » The skid shoes are located on each side of the auger housing and control the distance between the scraper blade and the ground. Adjust skid shoes equally to keep the scraper blade level with the ground.
- » The scraper blade & skid shoes are subject to wear and damage. Both scraper blade and skid shoes are adjustable to compensate for wear. They should be checked and adjusted periodically. Replace when necessary.

 *Damage to auger housing will result if scraper blade wears down too far.*

- » Both scraper blade and skid shoes have two wear edges. When one side wears out, they can be rotated 180° to use the other edge.

SHEAR PINS

- » The augers are secured to the auger shaft with shear pins and clevis pins. If the auger should strike a foreign object or ice jam, the snow blower is designed so that the pins may shear, preventing damage to any other components. If augers will not turn, check to see if the pins have sheared. Replace the shear pins if necessary.

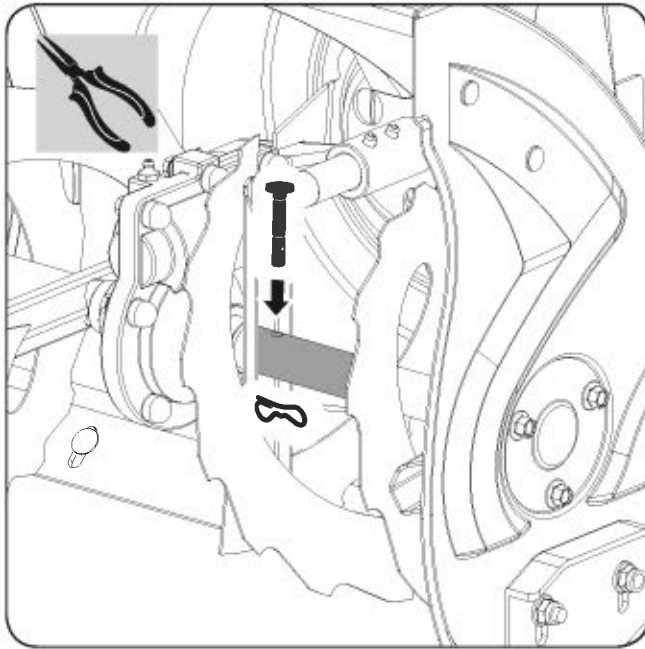

Figure 11



Do not substitute. Use only original equipment shear pins as supplied with your snow blower.

AUGER

- » When engaged, the augers rotate and draw snow into the auger housing.

DISCHARGE CHUTE

- » Snow drawn into the auger housing is discharged out the discharge chute.

CHUTE CLEAN-OUT TOOL



Never use your hands to clear a clogged discharge chute. Shut off engine and remain behind handles until all moving parts have stopped before unclogging.

1. Release the auger clutch lever and shut off the engine.
2. Remove the clean-out tool from the clip which secures it to the rear of the auger housing.

3. Grasp the tool firmly by the handle and push and twist the tool into the discharge chute to dislodge the blockage.
4. Refasten the clean-out tool to the mounting clip on the rear of the auger housing.
5. Make sure the discharge chute is pointed in a safe direction (no vehicles, buildings, people, or other objects are in the direction of discharge). Restart the engine. While standing in the operator's position (behind the snow blower), engage the auger control for a few seconds to clear any remaining snow and ice from the auger housing and the discharge chute.

ENGINE ON/OFF SWITCH

- » The engine switch has two positions. OFF - engine will not start or run. ON - engine will start and run.

RECOIL STARTER HANDLE

- » The handle is used to start the engine.

FUEL SHUT-OFF VALVE

- » The fuel shut - off has two position. **CLOSED** (⊞) - use this position to service, transport, or store the unit.
- » **OPEN** (⊞) - use this position to run the unit.

THROTTLE CONTROL

- » The throttle control regulates the speed of the engine and will shut off the engine when it is moved to the **STOP** position. The throttle control moves between **FAST** (↶), **SLOW** (↷), and **STOP** positions.

CHOKE CONTROL

- » The choke control is used to choke the carburetor and assist in starting the engine. The choke control slides between the **CHOKE CLOSED** (↘) and **CHOKE OPEN** (↙) positions.



Never use choke to stop engine.

ADJUSTMENT

SKID SHOES

- Position the skid shoes based on surface conditions. For removal of snow in normal conditions, such as a paved driveway or sidewalk, place skid shoes in the higher position to give a 1/8" (3mm) clearance between the scraper blade and the ground. Use a middle or lower position when the area to be cleared is uneven.



It is not recommended to operate the snow blower on gravel as it can easily pick up and throw by the impeller, causing personal injury or damage to the snow blower and surrounding property.

- If you choose to operate the snow blower on a gravel surface, use extra caution and keep the skid shoes in position for maximum clearance between the ground and the scraper blade.



Always adjust skid shoes after adjusting scraper blade to prevent premature wear to scraper blade or damage to auger housing.

- To adjust the skid shoes:
1. Loosen the four hex nuts (two on each side) and carriage bolts. Move skid shoes to desired position.
 2. Make sure the entire bottom surface of skid shoe is against the ground to avoid uneven wear on the skid shoes.
 3. Retighten nuts and bolts securely.

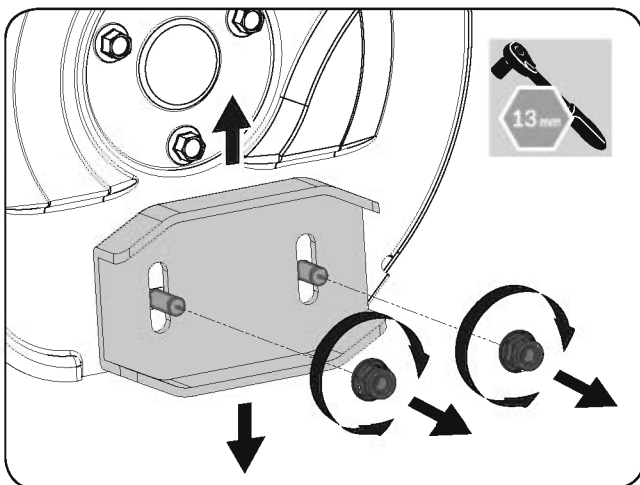

Figure 12

AUGER CLUTCH AND DRIVE CLUTCH

- When auger clutch lever or drive clutch lever is released and in the disengaged position, the cable should have very little slack.

- Auger must stop within 5 seconds when the auger clutch lever is released. If auger clutch does not engage or disengage properly, adjust auger clutch before operation.

- If the snow blower's drive is disengaging intermittently during operation, or it drives when you release the drive clutch lever, adjust the drive clutch before operation.

- Both auger clutch and drive clutch can be adjusted as follows:

1. Loosen lock nut on adjustment turnbuckle.
2. Turn the adjustment turnbuckle up and down to increase cable tension or provide more slack.
3. Retighten lock nut.

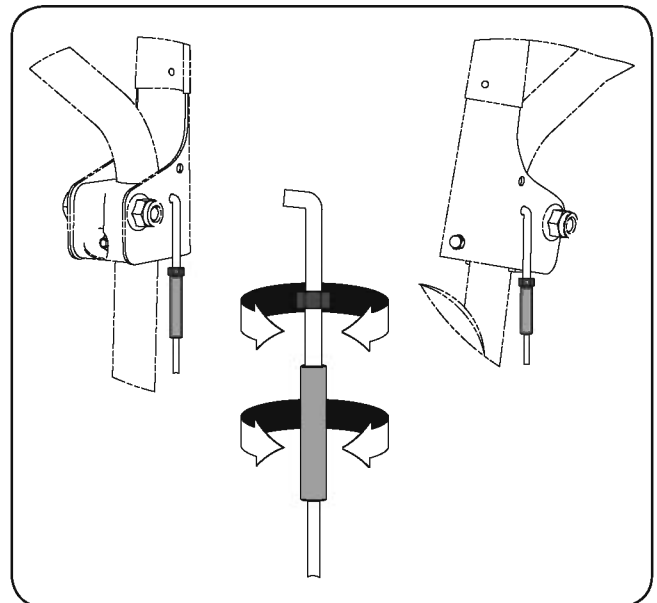

Figure 13

CHUTE BRACKET

- If the spiral at the bottom of the chute crank lever is not fully engaging with the chute assembly, the chute bracket can be adjusted.

» To do so:

1. Loosen the two nuts which secure the chute bracket and reposition it slightly.
2. Retighten the nuts.

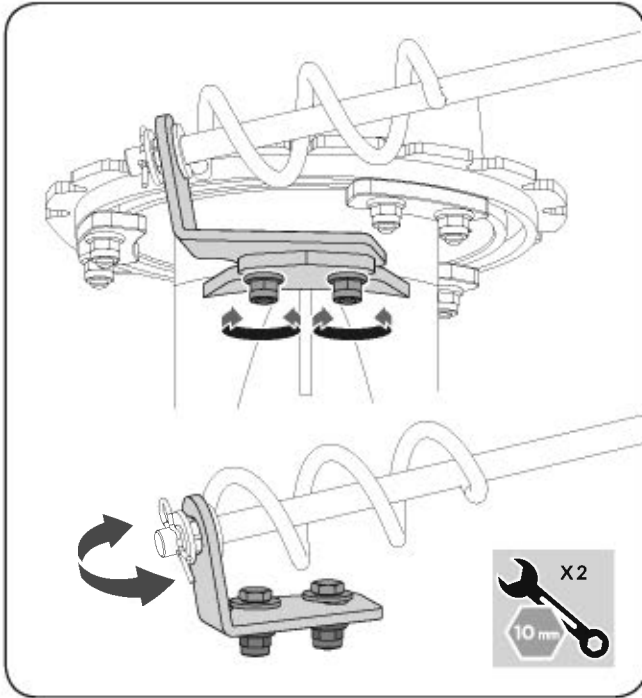

Figure 14

DRIFT CUTTERS (OPTIONAL)

Drift cutters break up snow drifts that are taller than the auger housing and direct the snow into the auger. Store the drift cutters on the auger housing when not in use. Reposition drift cutters so they face forward as shown. Wing nuts should be fastened on the outside of the auger housing.

»

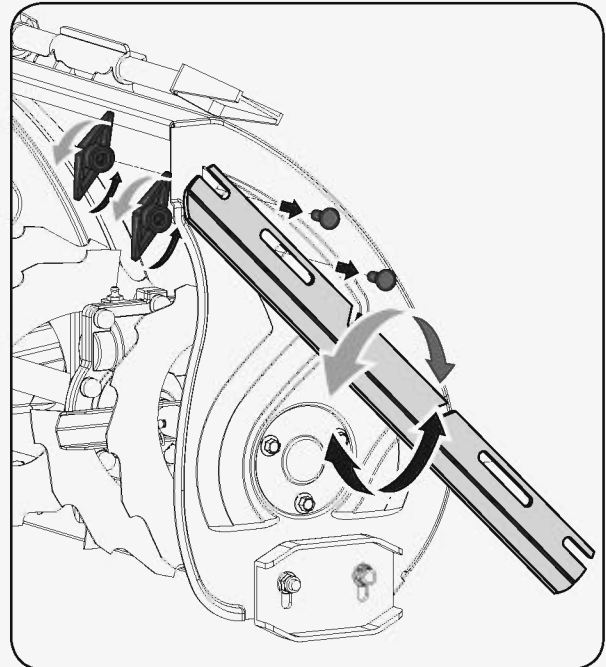

Figure 16a

PLASTIC SKID SHOES (OPTIONAL)

» Optional reversible poly skid shoes protect decorative surface.

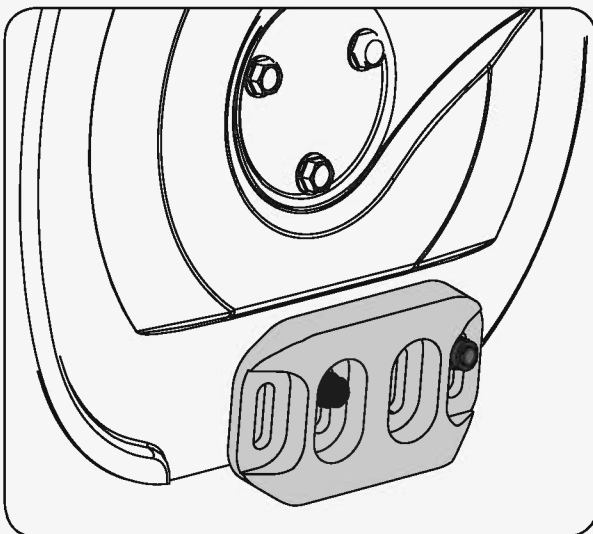

Figure 15

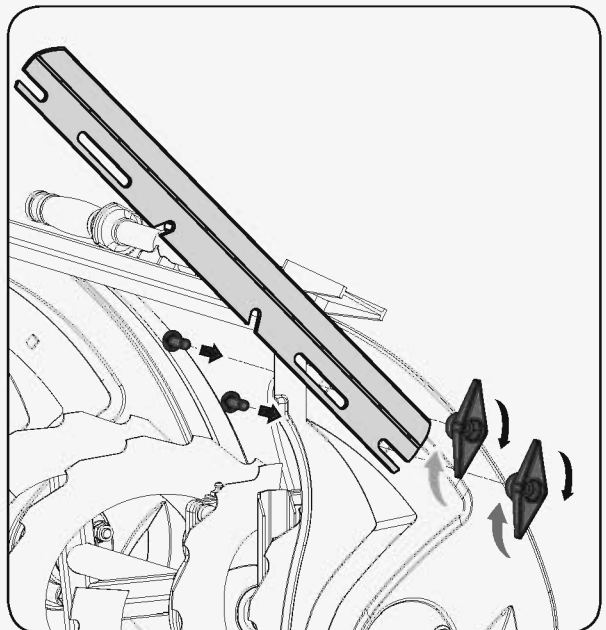

Figure 16b

OPERATION

FREEWHEELING AND SELF-PROPELLING

Left wheel equipped with the axle lock pin can be completely released by removing the pin and installing it in the outer axle hole. Unlock the left wheel to allow for easier turning of the unit.

To unlock the left wheel, remove the pin from the inner hole and insert the axle pin through the outer axle hole, but not through the wheel hub.

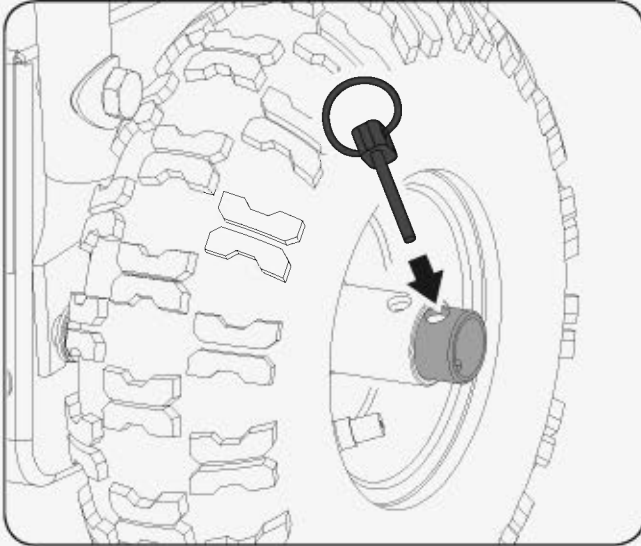

Figure 17a

To lock the left wheel, insert the pin through the wheel hub and the inner axle hole.

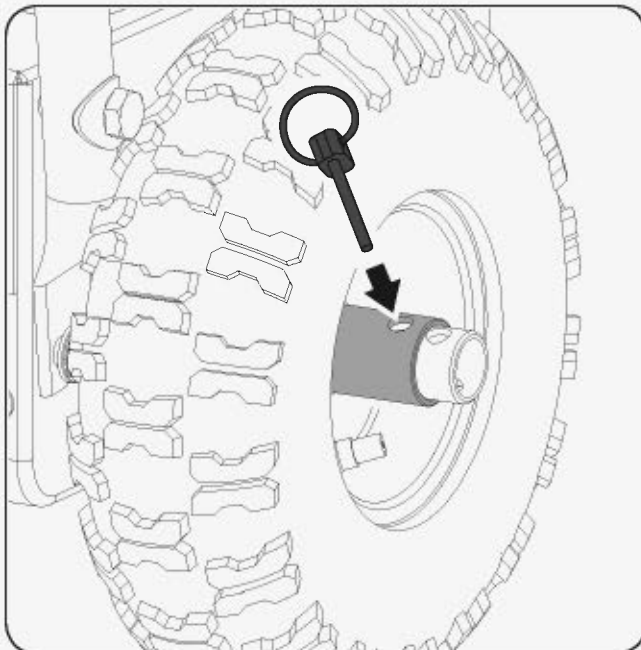



Figure 17b

STARTING AND STOPPING THE ENGINE



*Before starting the engine, check engine oil level and ensure the engine is served as described in the **Engine Manual** with the snow blower.*

COLD START - RECOIL STARTER

1. Be sure fuel shutoff valve is in the OPEN position.
2. Place ON / OFF switch in ON position.
3. Rotate choke control to CLOSED  position.
4. Push the primer 2 or 3 times. When temperature is below 15°F (-25°C), additional priming may be needed. When temperature is above 50°F (10°C), priming is not necessary.

» Over priming may cause flooding, preventing the engine from starting. If you do flood the engine, wait a few minutes before attempting to start and do not push the primer.

5. Grasp recoil starter handle and pull rope out slowly until it pulls harder. Let rope rewind slowly.
6. Pull rope with a rapid continuous full arm stroke. Do not allow starter rope to snap back.
7. Repeat steps 5 and 6 until engine starts.
8. When the engine starts, release the recoil starter handle and slowly move the choke control to the OPEN  position.

WARM START

Follow the steps above, keeping the choke control in the OPEN  position and do not use primer.

» Allow the engine to warm up for a few minutes, engine will not develop full power until it has reached normal operating temperature.

» In snowy and cold conditions, some controls and moving parts may freeze. Do not use excessive force when trying to operate frozen controls. If you have difficulty operating any control or part, start the engine and let it run for a few minutes.

SNOW BLOWING TIPS

It is easier and more efficient to remove snow immediately after it falls.

The best time to remove snow is the early morning. At this time the snow is usually dry and has not been exposed to the direct sun and warming temperatures.

Slightly overlap each successive path to ensure all snow will be removed.

For large areas, start in the middle and throw snow to each side, so snow is not cleared more than once.

For extremely heavy snow, reduce the width of snow removal by overlapping previous path and moving slowly.

Throw snow downwind whenever possible.

Keep engine clean and clear of snow during use. This will help air flow and extend engine life.

After snow-throwing is completed, let the engine run for a few minutes to help dry off the moisture on the engine and prevent moving parts from freezing. Engage the auger to clear any remaining snow from inside the housing. Rotate the discharge chute to prevent it from freezing. Stop the engine, wait for all moving parts to stop, and remove all ice and snow from the snow blower. With the engine off, pull the recoil starter handle several times to prevent the recoil starter from freezing up.

TRAVELING

To travel from one work area to another:

1. Set throttle to slow or part-throttle position.
2. Press down on handle bars enough to raise front of unit slightly off surface.
3. Engage drive clutch without engaging auger clutch.

TRANSPORT



Always shut off engine, remove key, and close fuel shut-off valve when transporting unit on a truck or trailer. Do not transport machine while engine is running.

Use extra care when loading or unloading unit onto trailer or truck.

Secure unit chassis to transport vehicle. Never secure from rods or linkages that could be damaged.

MAINTENANCE

ENGINE

Refer to the Engine Operator's Manual.

AUGER GEARBOX

The gearbox was filled with lubricant to the proper level at the factory. Unless there is evidence of leakage or service has been performed on the gearbox, no additional lubricant should be required. If lubricant is required, use GL-5 or GL-6, SAE85-95, EP gear oil lubricant. Do not use synthetic oil.

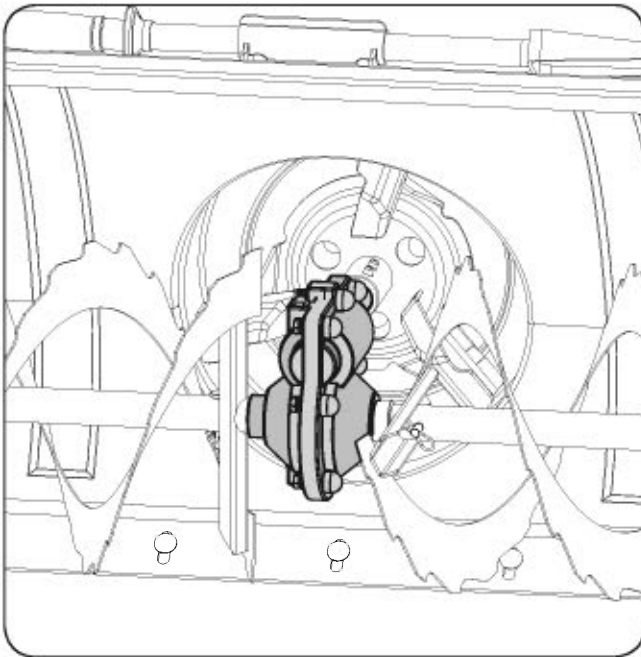

GENERAL LUBRICATION

Lightly lubricate all moving parts of the machine at the end of the season or every 25 operating hours.

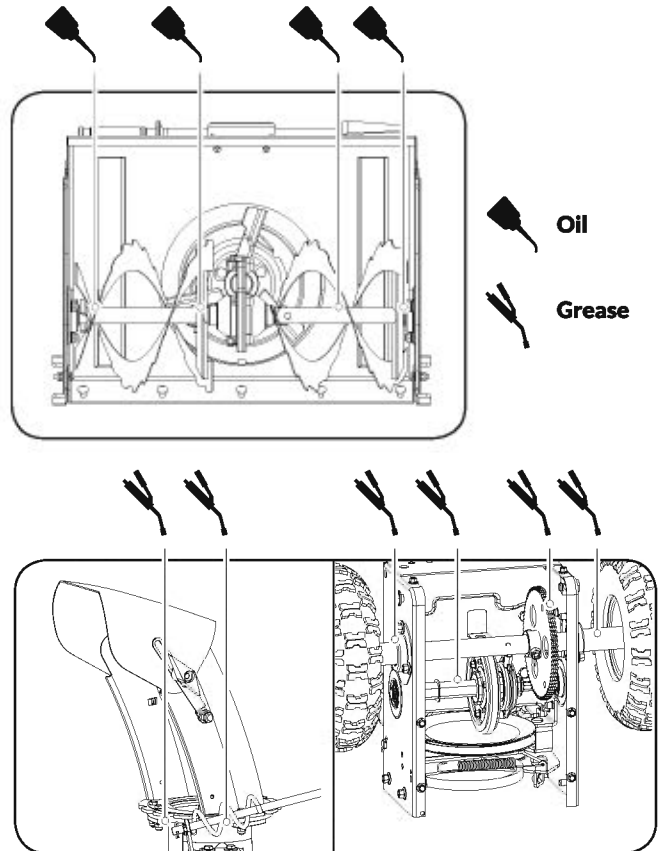

Do not allow grease or oil get on friction disc, friction plate or belts. Do not excessively oil the machine; extra oil may enter the traction drive and cause the traction drive belt to slip.

- » When lubricating auger shaft, remove shear pins to apply oil inside the shaft and around spacers and flange bearings found at either end of the shaft.
- » Remove the wheels to apply grease the wheel shaft.

SERVICE

REPLACEMENT SHEAR PINS

A pair of replacement auger shear pins and clevis pins are included with your snow blower. Store them in a safe place until needed.

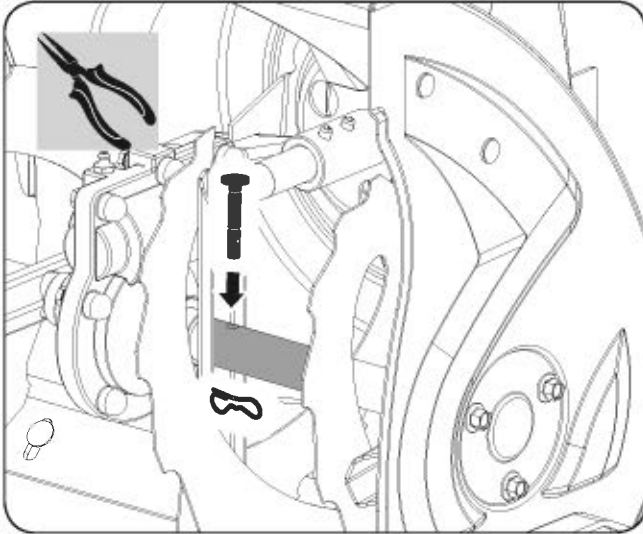

Figure 18



SPARE ROLL PINS

A pair of replacement impeller roll pins are included with your snow blower. Store them in a safe place until needed.

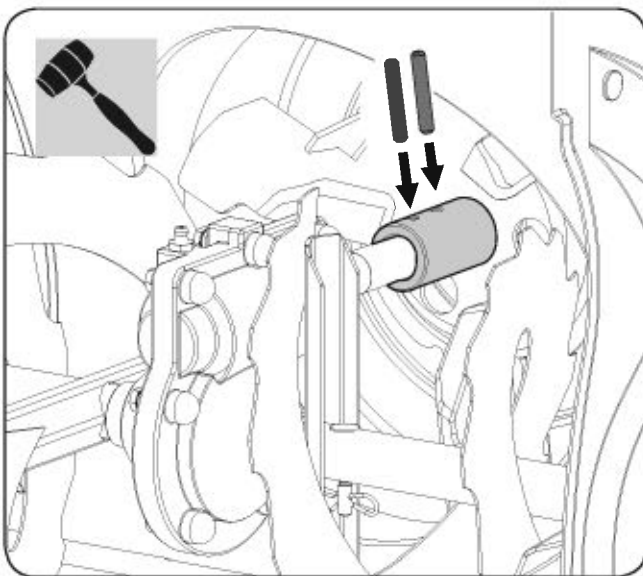

Figure 19



AUGER BELT REPLACEMENT

If the auger belt becomes worn, oil-soaked, or otherwise damaged, proceed as follows to replace the belt.

1. To prevent spillage, remove all fuel from tank by running engine until it stops. Remove the key to avoid unintended starting and allow unit to cool completely.
2. Remove the two screws that hold the belt cover in place and set the cover aside. (See **Figure 20a**)

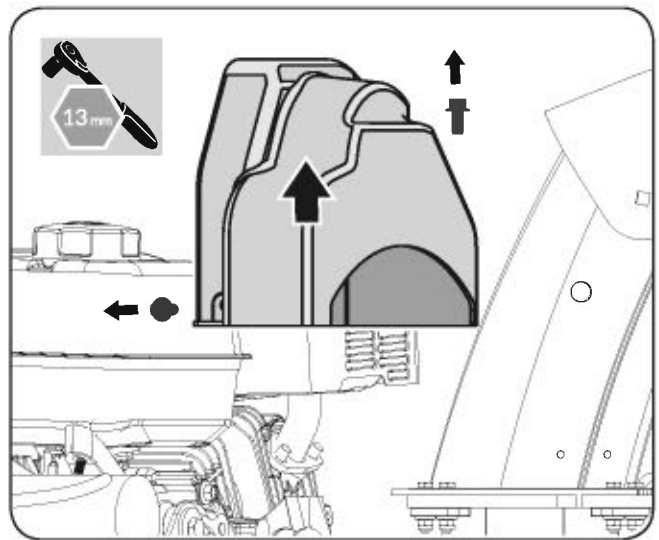

Figure 20a

3. Roll the auger belt(s) off the engine pulley. (See **Figure 20b**)

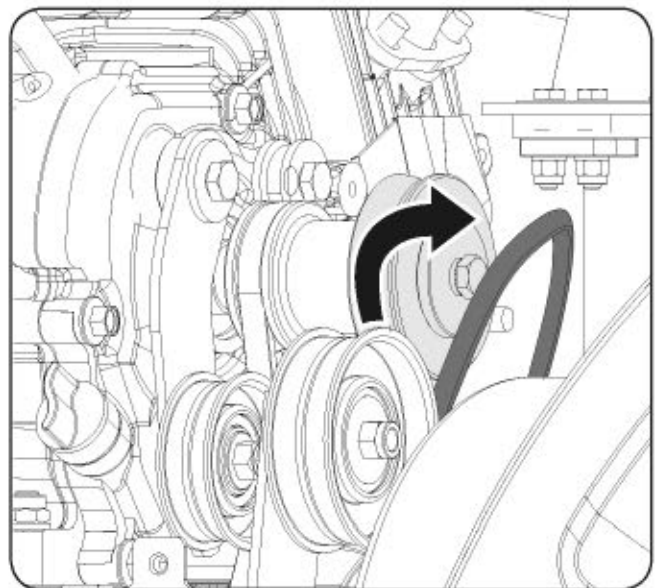

Figure 20b

- Carefully pivot the snow blower up and forward so that it rests on the auger housing.
- Remove the frame cover from the underside of the snow blower by removing the screws which secure the cover. (See **Figure 20c**)

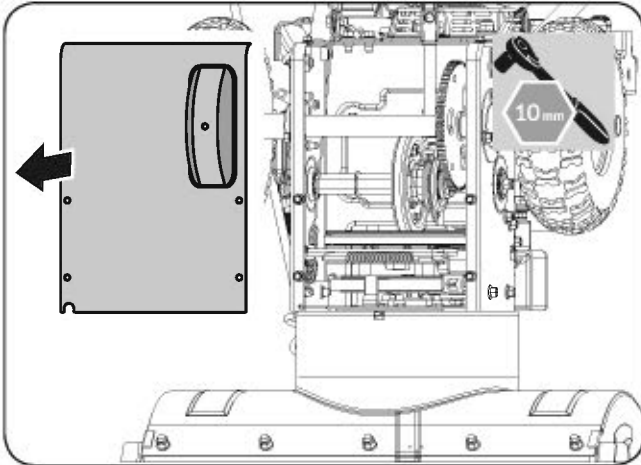

Figure 20c

- Release the spring from the connecting hole in the braking bracket. Bend the belt blocker a bit and move the braking bracket away from the belt. Remove the belt from around the auger pulley, and slip the belt between the support bracket and the auger pulley. (See **Figure 20d**)

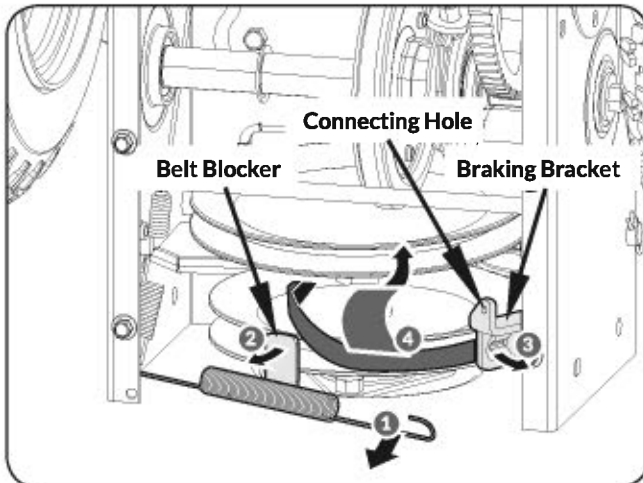

Figure 20d

- Replace the auger belt by following instructions in reverse order.
- Bend the belt blocker to the home position.

DRIVE BELT REPLACEMENT

If the drive belt becomes worn, oil-soaked, or otherwise damaged, proceed as follows to replace the belt.

- To prevent spillage, remove all fuel from tank by running engine until it stops. Remove the key to avoid unintended starting and allow unit to cool completely.

- Remove the two screws that hold the belt cover in place and set the cover aside. (See **Figure 20a**)
- Remove the belt as follows.
 - Roll the auger belt off the engine pulley. (See **Figure 20b**)
 - Pivot the idler pulley toward the right to relieve tension. (See **Figure 21a**)
 - Lift the drive belt off engine pulley. (See **Figure 21a**)

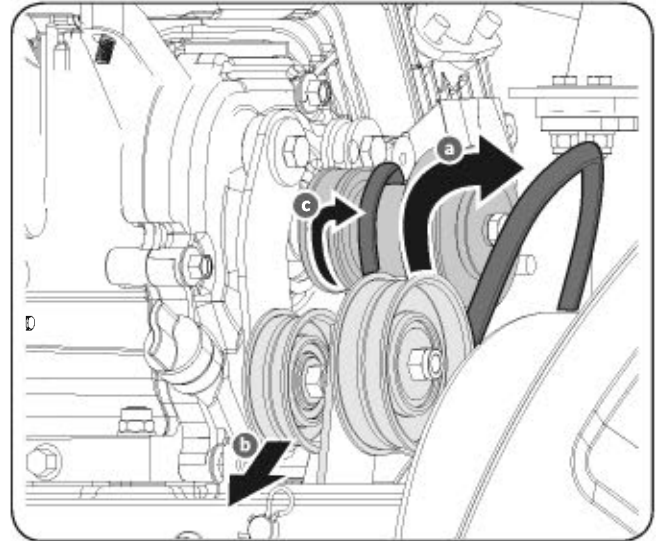

Figure 21a

- Carefully pivot the snow blower up and forward so that it rests on the auger housing.
- Remove the frame cover from the underside of the snow blower by removing the screws which secure the cover. (See **Figure 20c**)
- Slip the drive belt off the pulley and between friction wheel and friction wheel disc. (See **Figure 21b**)

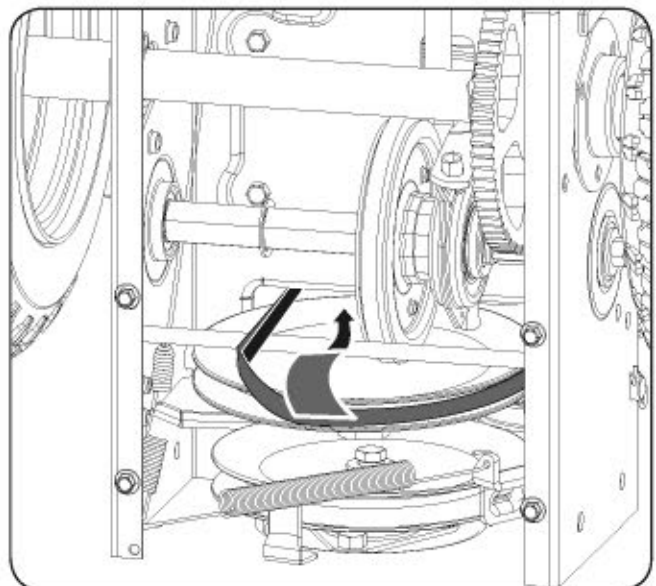

Figure 21b

- Remove and replace belt in the reverse order.

» Holding down the drive clutch lever will ease reinstallation of the belt.

If an assistant is available, you can also separate the auger housing from the frame assembly to replace belts.

- Shut off engine, remove key, disconnect spark plug wire and allow unit to cool completely.
- Remove belt cover. (See **Figure 20a**)
- Remove the clevis pin and washer from the directional chute control to remove it from the lower bracket.
- Remove bottom cover to avoid bending it when tipping unit apart. (See **Figure 20c**)
- Remove the screws securing auger housing to the frame (two on each side). Tip auger housing and frame apart. (See **Figure 21c**)

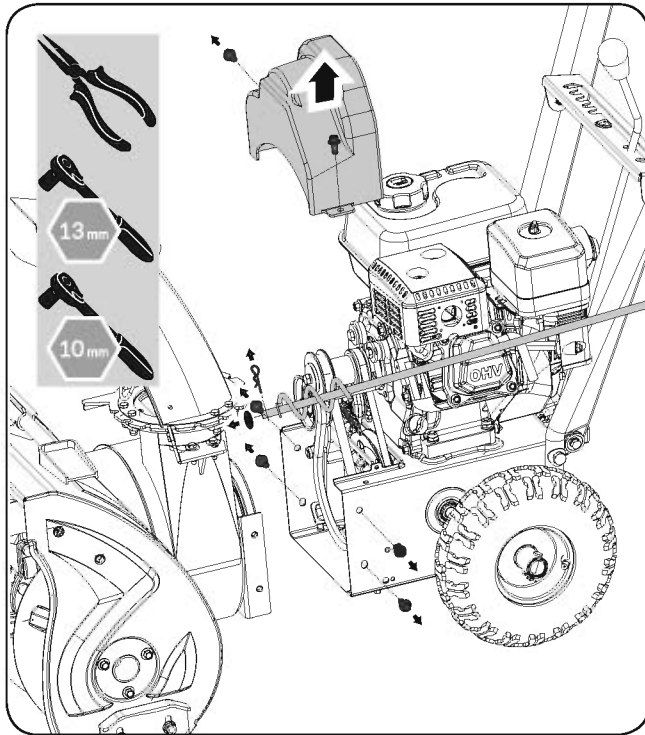

Figure 21c

- Replace auger belt or drive belt.
- Tip auger housing and frame back together and secure with screws.

» Holding down the auger clutch lever will ease reconnection of the auger housing and frame.
- Place belt(s) onto engine sheave(s).
- Reinstall the directional chute control.

FRICITION WHEEL REPLACEMENT

If the snow blower fails to drive with the drive clutch engaged, and performing the clutch control cable adjustment fails to correct the problem, the friction wheel may need to be replaced.

- To prevent spillage, remove all fuel from tank by running engine until it stops. Remove the key to avoid unintended starting and allow unit to cool completely.
- Carefully pivot the snow blower up and forward so that it rests on the auger housing.
- Remove the frame cover(s) from the underside of the snow blower by removing the screws which secure the cover(s). (See **Figure 20c**)
- Remove the right-hand wheel by removing the axle lock pin. (See **Figure 22a**)

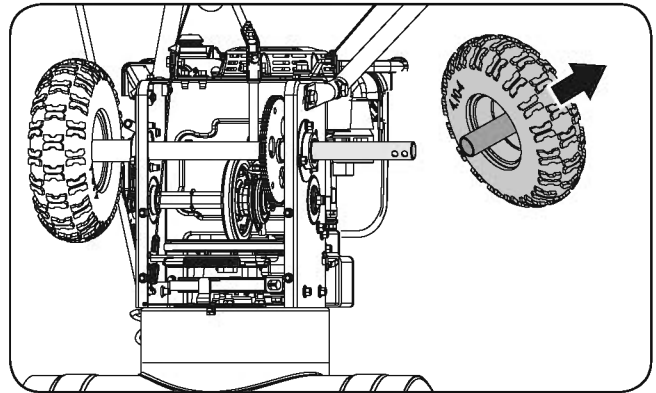

Figure 22a

- Carefully remove the hex nut which secures the hex shaft to the snow blower frame and lightly tap the shaft's end to dislodge the ball bearing from the right side of the frame. Be careful not to damage the threads on the shaft. (See **Figure 22b**)

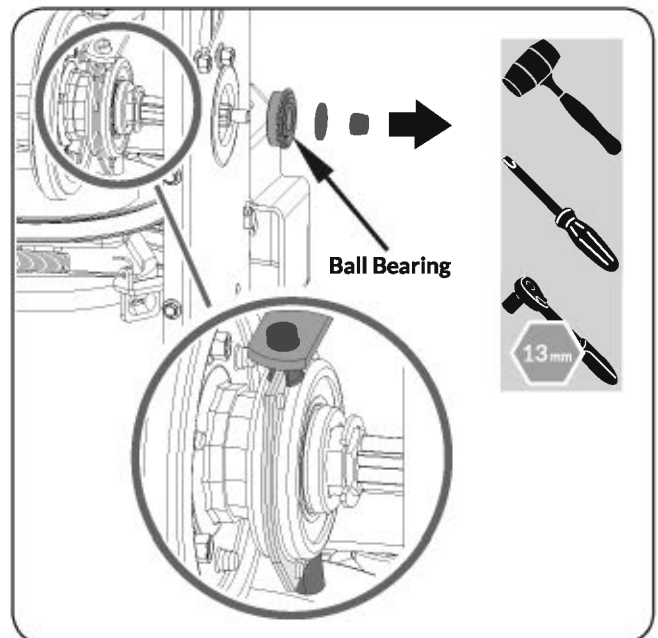

Figure 22b

6. Remove the other bearing from the left side of the frame by removing the snap ring.

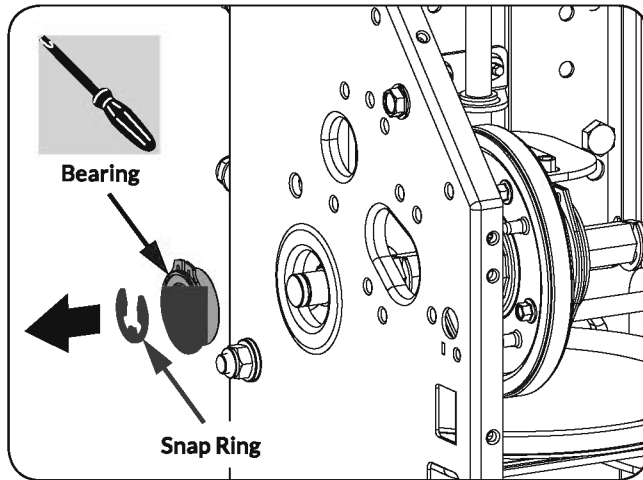

Figure 22c

7. Carefully position the hex shaft downward and to the left before carefully sliding the friction wheel assembly off the shaft.

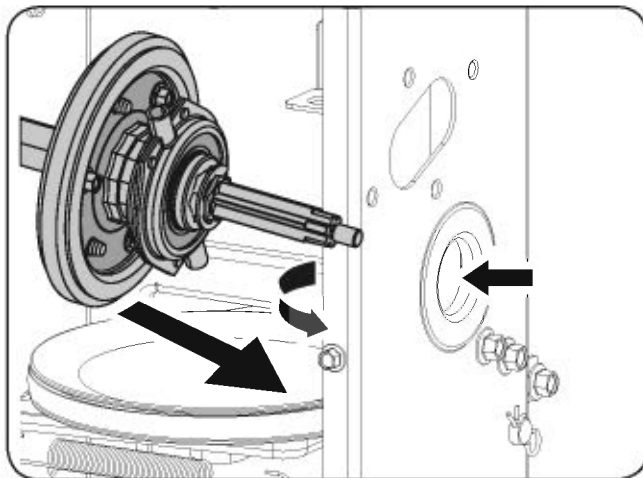

Figure 22d

8. Follow the previous steps in reverse order to reassemble.

If you only want to replace the rubber ring, proceed as follows:

1. Remove the six screws which secure the friction wheel's side plates together. (See **Figure 22e**)

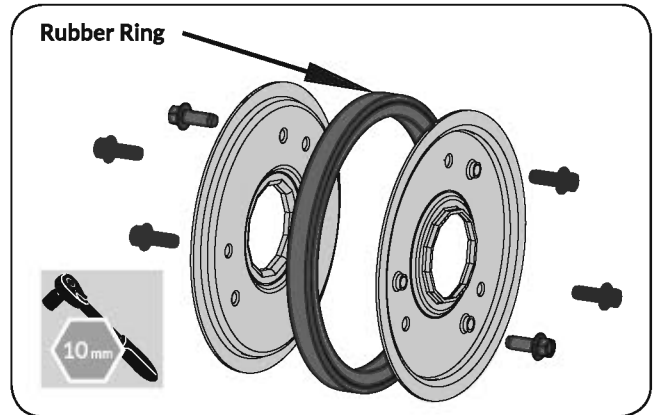

Figure 22e

2. Remove the rubber ring from between the plates.
3. Reassemble the side plates with a new rubber ring.

When reassembling the friction wheel assembly, make sure that rubber ring is centered and seated properly between the side plates. Tighten each screw only one rotation before turning the wheel clockwise and proceeding with the next screw on the other side of the wheel. Repeat this process several times to ensure the plates are secured with equal force between 6 ft-lbs(90N.m) and 9 ft-lbs(130N.m).

4. Slide the friction wheel assembly back onto the hex shaft. Make sure the shift lever pin is in place in the bearing housing. Follow the steps above in reverse order to reassemble components.

STORAGE



Refer to the Engine Manual for information on storing your engine.

At the end of the season or if the snow blower will not be used for 30 days or longer, follow the storage instructions below.

1. Run the engine until the fuel lines and carburetor are empty and it stops due to lack of fuel.
2. Remove the safety ignition key and allow the engine to cool.
3. Lubricate the machine as instructed.
4. Clean the exterior of the engine and the snow blower thoroughly.
5. Touch up all rusted or chipped paint surfaces; sand affected areas before painting, and use a rust preventative to prevent the metal parts from rusting.
6. Tighten all loose screws, bolts, and locknuts. Repair or replace any damaged parts.
7. Cover the machine and store it in a clean, dry place out of the reach of children.

TROUBLESHOOTING

Problem	Cause	Remedy
Engine fails to start	<ol style="list-style-type: none"> 1. Choke not in CHOKE position 2. Engine not primed 3. Engine is flooded 4. Fuel shut-off valve closed 5. Throttle in STOP position or RUN/STOP switch is STOP 6. Spark plug wire loose or disconnected 7. Fuel tank empty or stale fuel 8. Faulty spark plug 9. Safety ignition key is not inserted 10. The engine oil level in the engine crankcase is too low or too high 	<ol style="list-style-type: none"> 1. Move choke to CHOKE position 2. Prime engine as instructed in this manual 3. Wait a few minutes before restarting, do not prime 4. Open fuel shut-off valve 5. Move throttle to FAST position or RUN/STOP switch to RUN Position 6. Connect or tighten spark plug wire 7. Fill tank with clean, fresh gasoline and stabilizer 8. Clean, adjust gap, or replace 9. Insert safety ignition key 10. Add or drain oil to adjust the oil level in the engine crankcase
Engine idles or runs roughly	<ol style="list-style-type: none"> 1. Engine running on CHOKE 2. Fuel tank is nearly empty or stale fuel 3. Contaminated fuel supply 4. Carburetor out of adjustment 5. Engine over-governed 6. The fuel shutoff valve is not completely open or blockage in fuel line 7. Spark plug wire loose 8. Faulty spark plug 9. The engine oil level in the engine crankcase is too low or too high 	<ol style="list-style-type: none"> 1. Move choke lever to RUN position 2. Fill tank with clean, fresh gasoline 3. Replace with clean fuel 4. Contact a qualified repair personnel 5. Contact a qualified repair personnel 6. Open the fuel shutoff valve or clean fuel line 7. Tighten spark plug wire 8. Clean, adjust gap, or replace 9. Add or drain oil to adjust the oil level in the engine crankcase
The engine overheats	Carburetor not adjusted properly	Contact a qualified repair personnel
Excessive vibration	Loose parts or damaged parts	Tighten all fasteners or replace damaged parts
Loss of power	<ol style="list-style-type: none"> 1. Spark plug wire loose 2. Gas gap vent hole plugged 3. Dirty or clogged muffler 	<ol style="list-style-type: none"> 1. Tighten spark plug wire 2. Clean or replace fuel cap 3. Clean or replace muffler

Problem	Cause	Remedy
Loss of traction drive	<ol style="list-style-type: none"> 1. Drive control cable not adjusted properly 2. Drive belt loose or damaged 3. Friction wheel worn 	<ol style="list-style-type: none"> 1. Adjust drive control cable 2. Replace drive belt 3. Replace friction wheel
Loss of snow discharge or slowing of snow discharge	<ol style="list-style-type: none"> 1. Discharge chute clogged 2. Augers or impeller jammed 3. Auger control cable not adjusted properly 4. Auger belt loose or damaged 5. Shear pin(s) sheared 6. Throttle not in FAST position when throwing snow 7. Moving too fast to clear the snow 8. Throwing too much snow 9. Trying to remove extremely heavy or wet snow 10. Auger is frozen in place 	<ol style="list-style-type: none"> 1. Unclog discharge chute 2. Remove debris or foreign object from augers or impeller 3. Adjust auger control cable 4. Replace auger belt 5. Replace with new shear pin(s) 6. Move throttle to FAST position 7. Shift into a lower gear 8. Reduce speed and width of swath 9. Do not overload with extremely heavy or wet snow 10. Move unit to a warm place to thaw
Discharge chute either does not lock into place or does not move	<ol style="list-style-type: none"> 1. The discharge chute control not adjusted properly 2. Chute assembly incorrectly 	<ol style="list-style-type: none"> 1. Adjust the discharge chute control 2. Disassemble chute control and reassemble as instructed in this manual
Machine does not properly clear the snow of the surface	<ol style="list-style-type: none"> 1. The skid shoes and/or scraper blade not adjusted properly 2. The pressure in the tires not equal 	<ol style="list-style-type: none"> 1. Adjust the skid shoes and/or the scraper blade 2. Check and adjust the pressure in one or both tires

PARTS DIAGRAM

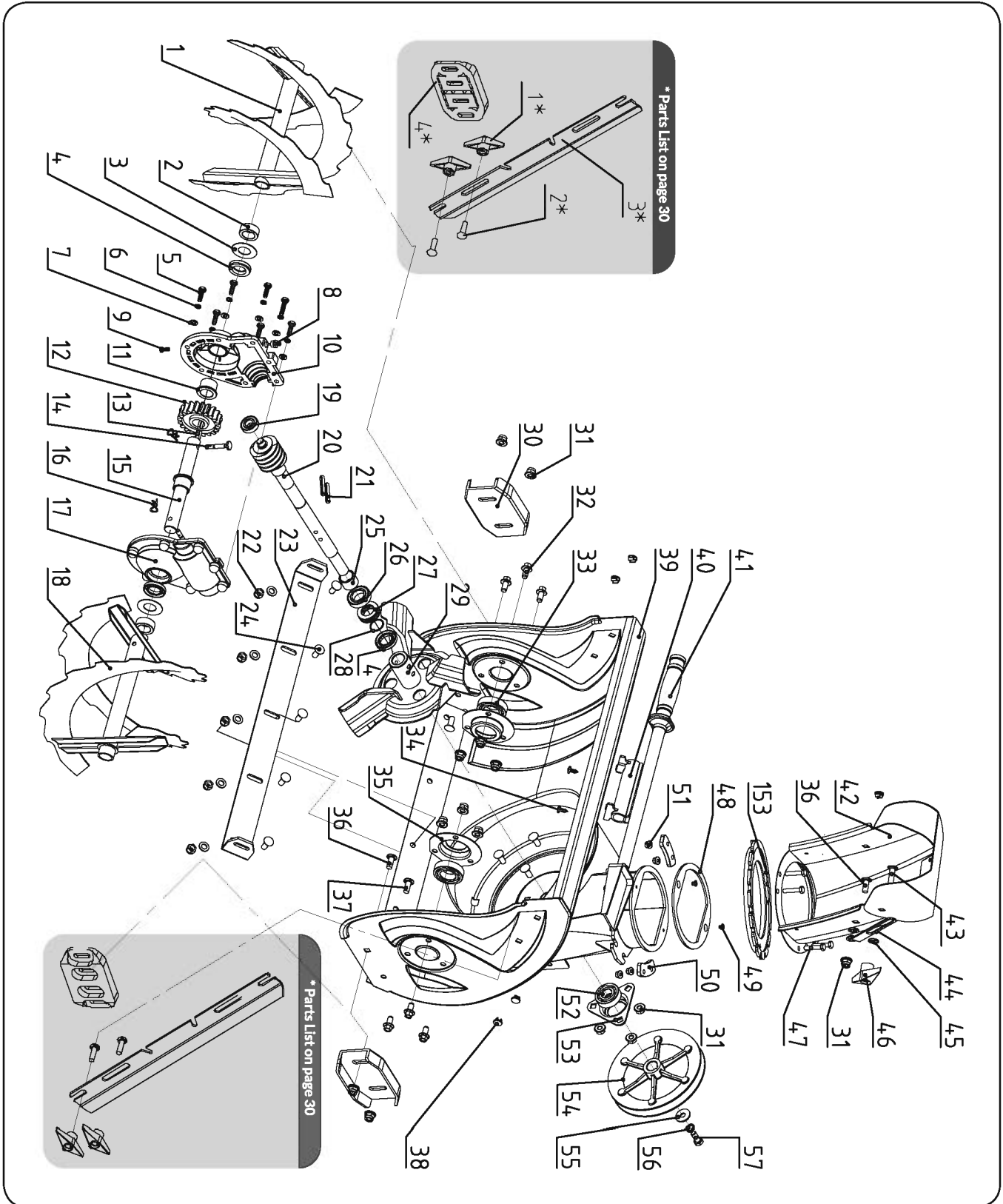

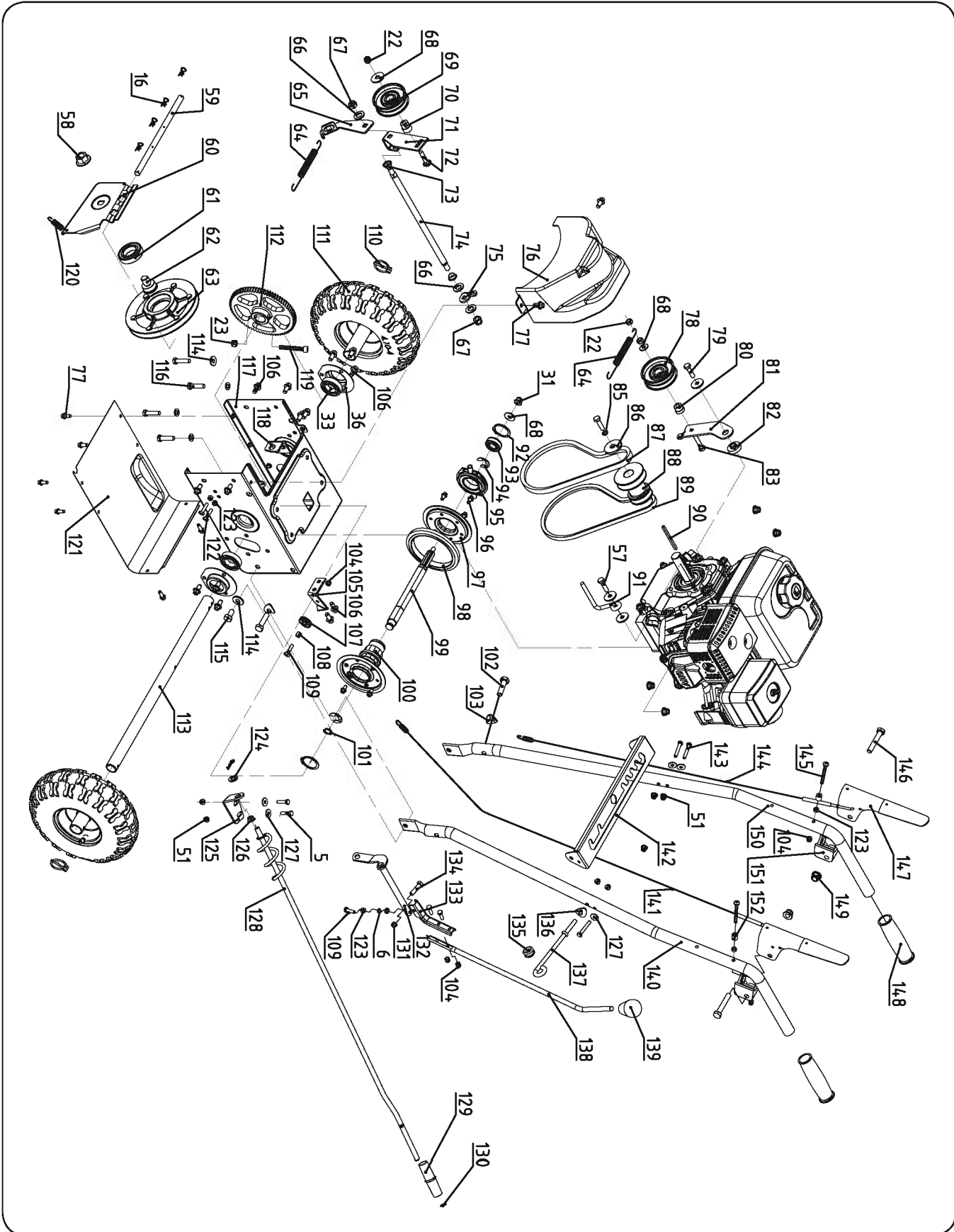

PARTS LIST

No.	Description	QTY	No.	Description	QTY	No.	Description	QTY
1	Spiral Assembly R	1	36	Bolt M8x20	6	71	Tension Pulley Plate	1
2	Washer	2	37	Bolt M8x25	2	72	Bolt M8x40	1
3	Big Washer	2	38	Plug	5	73	Plastic Sleeve	2
4	Sealing B20x35x7	3	39	Auger Housing Assy	1	74	Oscillating Bar	1
5	Bolt M6x20	10	40	Clean-Out Tool Mounting Bracket	1	75	Oscillating Plate	1
6	Spring Washer 6	11	41	Chute Clean-Out Tool	1	76	Belt Cover	1
7	Flat Washer 6	9	42	Discharge Chute	1	77	Screw M6x16	8
8	Oil Cup M10x1	1	43	Bolt M8x35	1	78	Drive Clutch Idler	1
9	Screw M5x10	1	44	Chute Linkage Plate	1	79	Bolt M8x30	1
10	Auger Gearcase Housing R	1	45	Lock washer	2	80	Bushing	1
11	Shaft Sleeve	2	46	Handle Knob Assembly	1	81	Drive Clutch Idler Bracket	1
12	Worm Wheel	1	47	Bolt M6x30	6	82	Spacer	1
13	Key 5x7.5x19	1	48	Discharge Chute Washer	1	83	Bolt M8x40	1
14	Shear Pin	2	49	Screw M5x6	2	84	Engine	1
15	Shaft	1	50	Chute Flange Keeper	3	85	Spring Washer 10	1
16	Clip 1.8	9	51	Flange Lock Nut M6	11	86	Engine Washer	1
17	Auger Gearcase Housing L	1	52	Bearing 6203-2RS	1	87	V-Belt 4LxA675	1
18	Spiral Assembly F	1	53	Bearing Housing	1	88	Belt Pulley	1
19	Bearing 6001-2RS	1	54	Big Pulley	1	89	V-Belt M28	1
20	Impeller Shaft	1	55	Big Flat Washer 8	2	90	Key 6x6x45	1
21	Roll Pin 6x37	2	56	Spring Washer 8	2	91	Belt Blocker	1
22	Locknut M8	17	57	Bolt M8x20	2	92	Circlip 35	3
23	Shave Plate	1	58	Flange Locknut M6x1.5	1	93	Bearing 6202-2RSN with Sealing	2
24	Bolt M8x16	5	59	Locating Shaft	1	94	Split Washer 15	2
25	Worm Sleeve	1	60	Driven Pulley Bracket	1	95	Shift Arm	1
26	Bearing 61904-2RS	1	61	Bearing 6006-2RS	1	96	Lock Screw M6x12	6
27	Bearing 51104	1	62	Driven Pulley Shaft	1	97	Friction Wheel Side Plate	2
28	Washer	1	63	Driven Pulley	1	98	Friction Wheel	1
29	Impeller Assembly	1	64	Chute Breaking Spring	2	99	Friction Wheel Shaft	1
30	Skid Shoe	2	65	Chute Breaking Plate	1	100	Shaft Sleeve	1
31	Flange Locknut M8	4	66	Washer 12	2	101	Circlip 15	1
32	Bolt M8x16	6	67	Locknut M10	1	102	Bolt 8.8 M10x40	2
33	Bearing 6005-2RS-T	4	68	Big Washer 8	4	103	Washer 10	2
34	Screw ST5.5x13	2	69	Chute Tension Pulley Assy	1	104	Locknut M6	6
35	Bearing Housing	4	70	Bearing Spacer	1	105	Auger Cable Holder 2	1

No.	Description	QTY	No.	Description	QTY	No.	Description	QTY
106	Screw M8x16	14	122	Bolt M6x35	2	138	Gear Shift Lever	1
107	Cable Roller	1	123	Nut M6	5	139	Knob	1
108	Roller Bushing	3	124	Washer 10	6	140	Left Handle Pipe	1
109	FT Bolt M6x25	2	125	Supporting Plate	1	141	Drive Clutch Cable	1
110	Lock Pin 8	2	126	Bushing	1	142	Gear Shift Board	1
111	Wheel	2	127	Big Washer 6	6	143	Bolt M6x40	3
112	Big Gear	1	128	Directional Chute Control Lever	1	144	Chute Adjustable Cable	1
113	Wheel Shaft	1	129	Directional Chute Control Knob	1	145	Screw M6x60	2
114	Big Washer 8	6	130	Circlip 10	1	146	Bolt M10x55	2
115	Bolt M10x20	2	131	Locknut M6	1	147	Lever	1
116	Bolt M8x35	4	132	Shifting Fork	1	148	Handle	2
117	Gearbox Housing	1	133	Spring Clip	1	149	Flange Lock Nut M10	2
118	Bracket	1	134	Bolt M6x30	1	150	Right Handle Pipe	1
119	Bolt M8x55	1	135	Rubber Bushing	1	151	Lever Bracket	2
120	Spring	1	136	Arc Washer 8	1	152	Bolt Sleeve	2
121	Frame Cover	1	137	Lever Bracket	1	153	Chute Crank Flange	1

OPTIONAL DRIFT CUTTERS

No.	Description	QTY
1*	Handle Knob Assembly	4
2*	Bolt M8x20	4
3*	Drift Cutter	2

OPTIONAL SKID SHOES

No.	Description	QTY
4*	Plastic Skid Shoe	2

Tame the Great Outdoors®

