

# Z1 350Z / G35 URETHANE MOTOR MOUNT INSTALLATION MANUAL



This Installation Manual is intended for the following models:	
2003-2008	Nissan 350Z
2003-2006	Infiniti G35 Sedan
2003-2007	Infiniti G35 Coupe

## PROLOGUE:

Study these instructions completely before proceeding to assembly. The installer must have a thorough knowledge of automotive systems operation. If unfamiliar with any of the concepts outlined in this instruction, we recommend the installation be completed by a qualified professional.

## WARNING!

Extreme caution should be taken when performing maintenance or performance upgrades to your vehicle. Please observe and abide by any Warning or Caution labels placed on the various components and tools used when servicing your vehicle. If you have any questions regarding installation or the various components included with the Z1 Motorsports 350Z / G35 Urethane Motor Mount, consult with a Professional Mechanic or contact Z1 Motorsports for more information.

## Parts Included:

Item	Quantity	Description
1	2	Z1 Urethane Motor Mount (Pre-assembled)

## TOOLS REQUIRED:

- Ratchet Accessories
- Ratchet
- Assorted Metric Sockets
- Assorted Metric Allen Wrenches
- Assorted Metric Wrenches
- Torque Wrench

## SAFETY REQUIREMENTS:

- Always wear safety glasses and any necessary protective garments. If using any fluids, chemicals, or solvents, a respirator is recommended.
- Always use properly rated jack stands when working under your vehicle.
- Always keep limbs and parts away from moving drivetrain parts.
- Only operate drivetrain in safe space and well-ventilated areas.



***Please note: This installation manual is intended to be used as a guide with the installation and servicing of the Z1 Motorsports 350z/G35 Urethane Motor Mounts ONLY. This manual does not include or offer any suggestions for either removing the engine or replacing the motor mounts while the engine is still installed in the vehicle.***



## BEFORE YOU BEGIN:

Remove contents from the Z1 Motorsports 350Z / G35 Urethane Motor Mount Kit and verify that ALL necessary hardware is present.

## PROCEDURE:

### **Installation Note #1:**

The Z1 Motorsports 350Z / G35 Urethane Motor Mounts come pre-assembled from Z1 Motorsports. There is no need to disassemble or service the bushing units prior to installation. If you find that additional height, spacing or adjustment is needed due to a custom installation or application, these motor mounts can be adjusted +0.5625" (~14.00 mm) [Raising the motor] and - 0.07" (1.75mm) [Lowering the motor].

Due to limitations and spacing issues between the cross member and the oil pan, as well as other potential alignment concerns on standard 350Z & G35 applications, the Z1 Motorsports 350Z/G35 Urethane Motor Mounts should not be lowered further. Do not attempt to modify the mounts in any way beyond what this installation manual details in order to achieve a lower engine height.

1. Assure the car's ignition is in the OFF position and the NEGATIVE (-) battery terminal is disconnected.
2. Place the transmission in Park position (or in Reverse gear if equipped with a manual transmission). Apply the parking brake.
3. Locate proper jacking points on vehicle's chassis (refer to vehicle's Owner Manual). Raise and support vehicle using jack & jack stands.
4. Refer to Factory Service Manual (FSM) to remove existing motor mounts from engine. Retain the factory 14mm motor mount nuts. DO NOT DISCARD THESE!

5. Insert the upper motor mount stud into the factory motor mount bracket on the engine block. Tighten the 14mm motor mount nut by hand at this time.
6. Keeping in mind such items as the Turbos (on Twin Turbo applications), A/C Compressor and brackets, exhaust manifolds/downpipes, etc. Rotate the Z1 Motorsports 350Z Urethane Motor Mount so that the access window exposing the 17mm bolt head is easily reached once installed on the motor.

**Note:** When tightening both the upper and lower motor mount nuts, you may find that it is beneficial to insert a 14mm wrench into the opening on the Z1 Urethane Motor Mounts to prevent the internal urethane motor mount bolt from slipping while completing the installation.

7. Torque the upper nut to between 32-40ft-lbs. It is also recommended that some form of thread locking compound be applied for additional security.

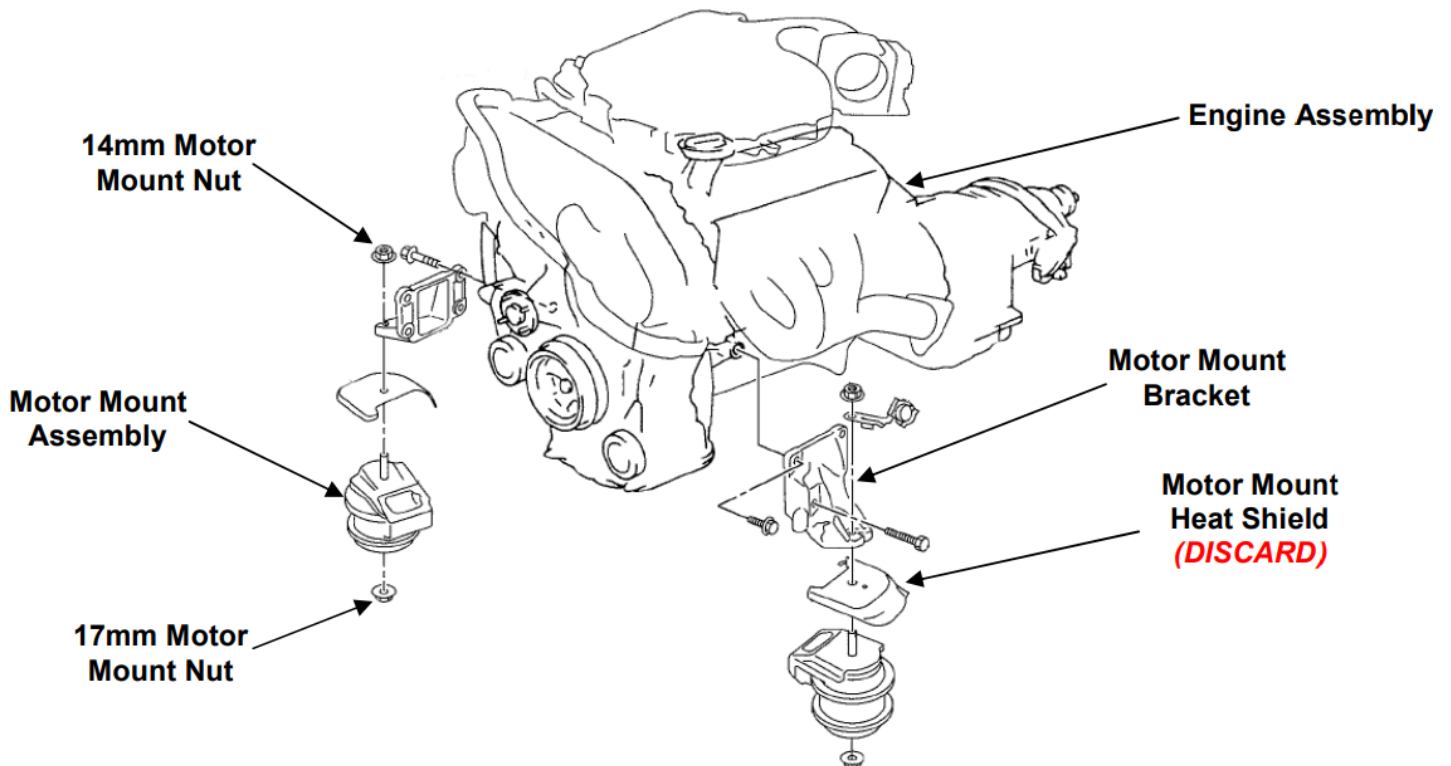

8. Once the motor has been reinstalled onto the engine's cross member, torque the lower nut to between 65-72ft-lbs. Again, it is recommended that some form of thread locking compound be applied for additional security.

**Installation Note #2:**

Due to the nature of urethane bushings and its increased stiffness, additional engine vibration will be transferred into the chassis. No additional engine noise or harshness will result from installing the Z1 Motorsports Urethane Motor Mounts.

**END**

**Additional Technical Support:**  
 Contact Z1 Motorsports at [info@z1motorsports.com](mailto:info@z1motorsports.com)  
 Or call 770-838-7777 between 9am and 6pm ET

# Servicing, Disassembly & Reassembly:

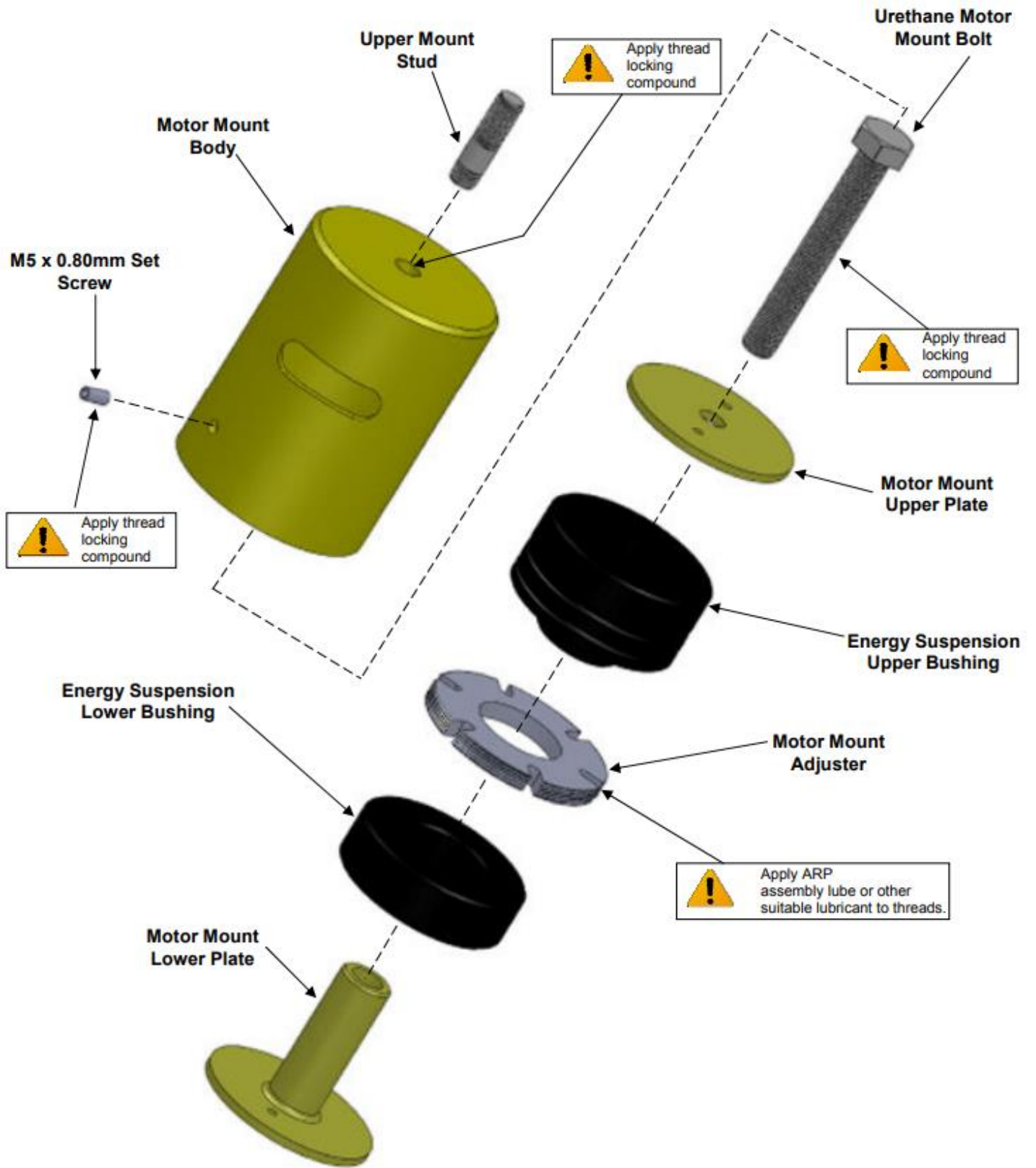

**When servicing or adjusting the Z1 Motorsports 350Z/G35 Urethane Motor Mount Bushings, follow below mentioned steps in sequence when disassembling or reassembling the units. (Refer to the Motor Mount exploded view on the previous page for part sequencing and locations).**

### **Disassembly:**

1. Remove the motor mount lower plate by unthreading it from the assembly.

Note: The out rim of the lower plate can be placed into a bench vise. Using a 17mm wrench, insert it into the window on the motor mount body and attach it to the 17mm motor mount bolt. Turn the wrench counterclockwise to loosen the bolt. The entire body assembly will spin, unscrewing the motor mount lower plate.

2. Remove the 17mm wrench from the opening and set aside.
3. Remove the Energy Suspension lower bushing from the motor mount body.
4. Remove the M5 x 0.80mm set screw.
5. Unscrew the motor mount adjuster from the body

**BE CAREFUL NOT TO DAMAGE THE THREADS ON EITHER THE MOTOR MOUNT BODY OR THE MOTOR MOUNT ADJUSTER.**

6. Remove the Energy Suspension upper bushing from the motor mount body.
7. The urethane motor mount bolt and upper plate can remain inside of the motor mount body. Removal is not needed unless to replace a damaged component.

### **Reassembly:**

1. Reinstall all previously removed components in the reverse order mentioned above.

Note: Be sure to lubricate the threads on the motor mount adjuster and those on the motor mount body to ensure smooth travel/engagement. Apply a suitable thread locking compound to the threads on the motor mount bolt.

Screw the motor mount adjuster until it reaches a depth of 9/16" (0.5625") to achieve a factory motor mount height. Reinsert the M5 x 0.80mm set screw to prevent the motor mount adjuster from spinning while completing the final steps of assembly.

2. Once all components are reinserted into the motor mount body, use the 14mm wrench previously used and reinsert it into the motor mount body's window.
3. Tighten the 17mm motor mount bolt by turning the wrench clockwise. Tighten the bolt/motor mount body assembly until the bolt bottoms out.

Note: By tightening the 17mm motor mount bolt, you are pre-loading the Energy Suspension bushings to the proper specification. Some resistance will be felt as you tighten the bolt. Only when the bolt stops spinning, successfully compressing the upper and lower bushings, will the preload be achieved.

